



MODEL H7585 RESAW FENCE FOR G0513 INSTRUCTION SHEET

Introduction

Installing the new fence requires replacing the original fence with the new fence support tube on the fence base, attaching the resaw fence, then putting on the new fence scale.

Inventory

- Resaw Fence 1
- Fence Support Tube 1
- Flat Washer 8mm..... 1
- Moving Plate..... 1
- Adjustment Handle 1
- Scale 1
- Cap Screws M6-1 x 30..... 4

Installing Fence Support Tube

1. Remove the four cap screws (**Figure 1**) and remove the fence from your original fence base.
2. Install the fence support tube on the fence base with the spacer plate between the them, as shown in **Figure 2**.

Attaching Resaw Fence

1. Insert the adjustment handle with washer through the hole in the fence and attach the moving plate on the other side (**Figure 3**).
2. Slide the resaw fence over the moving plate, center it with your original fence, and lock it in position with the adjustment handle.

Installing Scale

1. Raise the blade guides, and place the resaw fence against the blade.
2. Note where scale indicator line is over the old scale, and pencil a mark on the rail next to the scale.
3. Remove the old scale and install the new scale so the 0 is even with your pencil mark.



Figure 1. Four cap screws to be removed for changing fences.

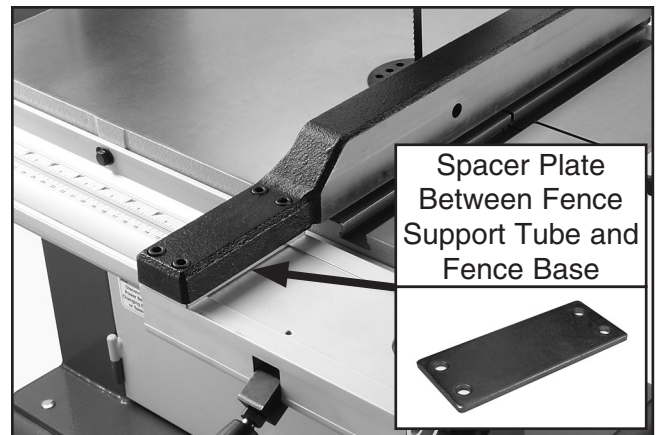

Figure 2. New fence support tube installed.

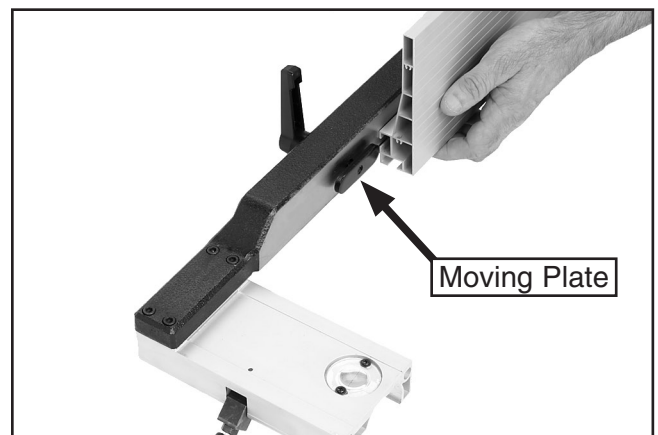
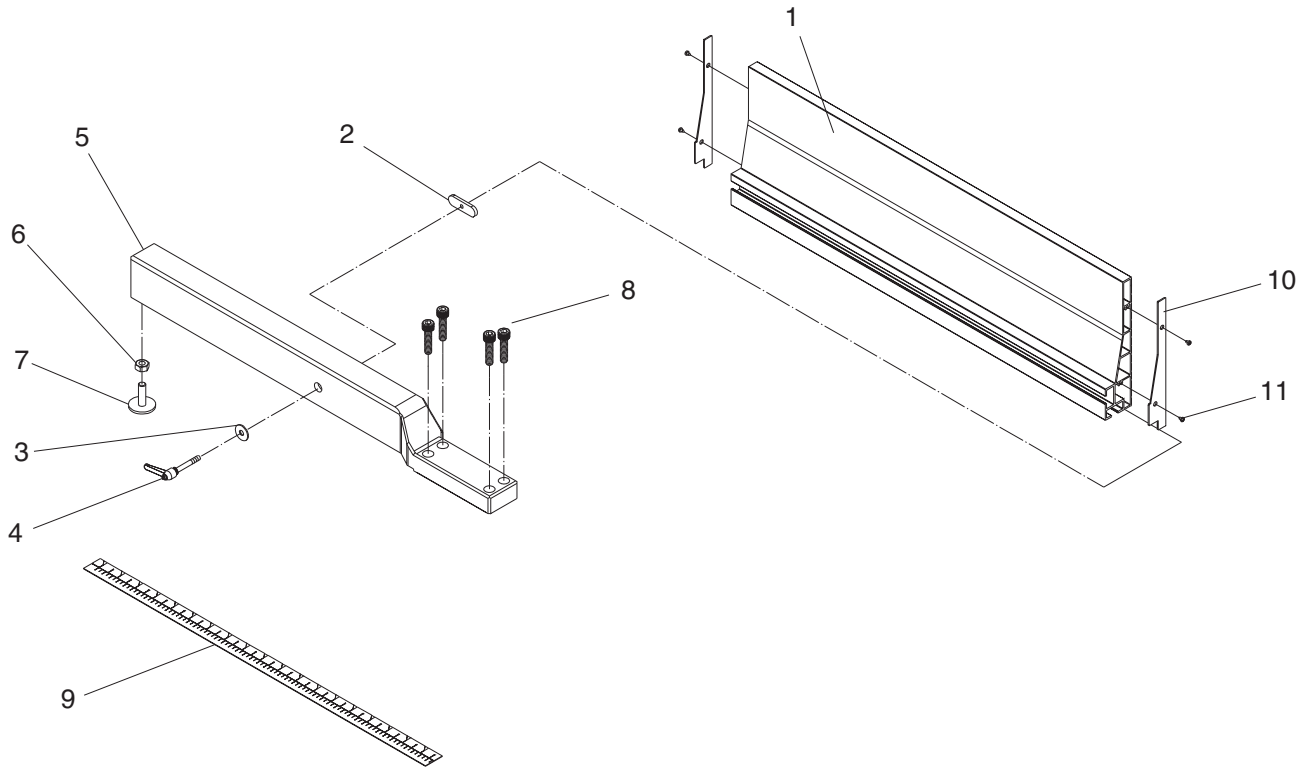

Figure 3. Installing resaw fence.

H7585 Parts Breakdown and List



REF	PART #	DESCRIPTION	QTY
1	PH7585001	RESAW FENCE (AL) 590mm	1
2	PH7528002	MOVING PLATE	1
3	PW01M	FLAT WASHER 8MM	1
4	PH7528004	ADJUSTMENT HANDLE M8 X 44	1
5	PH7588007	FENCE SUPPORT TUBE 590MM	1
6	PN01M	HEX NUT M6-1	1
7	PH7584007	ADJUST SCREW	1
8	PSB07M	CAP SCREW M6-1 X 30	4
9	PH7588021	SCALE	1
10	PH7528005	END COVER 148 X 22 X 1	2
11	PHTEK3M	TAP SCREW M3.5 X 8	4

COPYRIGHT © JUNE, 2005 BY GRIZZLY INDUSTRIAL, INC. REVISED NOVEMBER, 2006.

WARNING: NO PORTION OF THIS MANUAL MAY BE REPRODUCED IN ANY SHAPE OR FORM WITHOUT THE WRITTEN APPROVAL OF GRIZZLY INDUSTRIAL, INC.

#TR7287 PRINTED IN TAIWAN

For replacement parts, call 1-800-523-4777. For help, call Technical Support at 1-570-546-9663 or email tech-support@grizzly.com.