

NP1000/2000 Installation Guide Desktop and Ceiling Mount

v 1.1

Contents

Product Description, Lens Specs, Screen/Aspect Ratio	
Notes and Formulas	Pg 1
Diagrams & Distance Charts; 4:3	Pg 2
16:9	Pg 3
Lens Shift Adjustable Range	Pg 4
Cabinet Dimensions	Pg 5
Lens Dimensions	Pg 6
Ceiling Mount Dimensions	Pg 7
Ceiling Mount Dimensions	Pg 8
Input Panel and Control Codes	Pg 9

Product Description

Type: 3 panel LCD projector, 0.8 p-Si TFT w/MLA	Dimensions: 15.7"(W) x 5.9"(H) x 14.1"(D)
Resolution: 1024 x 768 (4:3) / 1024 x 576 (16:9)	Weight: 16.1 lbs
Network Ready, integrated wired/optional wireless	Brightness: NP1000 – 3500 ANSI Lumens NP2000 – 4000 ANSI Lumens
	Manual: Lens Shift, Horizontal & Vertical /Zoom/ Focus

Lens Specifications

NP01FL: Throw Ratio: ~ 0.8:1 Screen Sizes: 40"-150"	Focal Length: 13.2mm F#:2.3	NP03FL: Throw Ratio:~1.94 - 3.07:1 Screen Sizes: 40" - 500"	Focal Length:31.6 – 50.2mm F#:2.2
NP02FL: Throw Ratio: ~1.18 - 1.54:1 Screen Sizes: 30" - 500"	Focal Length: 19.42 - 25.26mm F#:2.2	NP04FL: Throw Ratio:2.98 -4.77:1 Screen Sizes: 60" - 500"	Focal Length:48.8 - 77.6mm F#:2.2
Standard: Throw Ratio:~1.5 - 2.0:1 Screen Sizes: 30" – 500"	Focal Length:24.4 - 32.5mm F#:1.7	NP05FL: Throw Ratio:4.62 - 7.02:1 Screen Sizes: 80" - 500"	Focal Length:76.6 - 116.5mm F#:2.2

Screen/Aspect Ratio

Both 4:3 and 16:9 screens are fully supported with proper aspect ratio control for both type sources using NEC developed scaling technology. Menu selections have settings for each screen type and aspect ratio control for each source type.

Notes

- For screen sizes not indicated on the projection tables, use the formulas below. If the figures on the tables do not match the results of formulas, use the figures in the table.
- All calculations are based on 4:3 aspect ratio.
- Distances are in inches, for millimeters multiply by 25.4.
- Distances may vary ±5%.

Formulas

The Projection Formulas use the image width for calculation. Image width is the same for all aspect ratios, only vertical image size varies. For proper projector placement, determine the image width for a desired screen size. Use the Screen Formulas below to calculate all screen dimensions. Plug in the image width for "W" in the Projection Formulas.

Refer to the diagrams and charts for popular screen sizes on page 2 and 3:

Projection Formulas:

NP01FL:	C = 0.8325H – 1.33	
NP02ZL:	C (Wide) = 1.2220H – 1.798	C (Tele) = 1.5894H – 1.795
Standard:	C (Wide) = 1.5455H – 2.022	C (Tele) = 2.0555H – 2.015
NP03ZL:	C (Wide) = 2.0069H – 2.830	C (Tele) = 3.1710H – 2.840
NP04ZL:	C (Wide) = 3.0537H – 4.830	C (Tele) = 4.8860H – 4.850
NP05ZL:	C (Wide) = 4.8275H – 7.625	C (Tele) = 7.3379H – 7.645

Definitions:

W = Image Width
H = Image Height (size)
C = Throw distance

4:3 Screen Formulas:

W = H x 4/3
H = W x 3/4
Diagonal = W x 5/4

16:9 Screen Formulas:

W = H x 16/9
H = W x 9/16
Screen Diagonal = W x 18.358/16

Note: Tilting the front of the projector from level up or down by more than 45° could reduce lamp life up to 20%.

NP1000/2000 Installation Guide

Desktop and Ceiling Mount

v 1.1

Projection Distance and Screen Size for Ceiling Mount

The following shows the proper relative positions of the projector and screen. Refer to the table to determine the position of installation.

Distances are in inches. For millimeters multiply by 25.4.

Ceiling Mount Installation

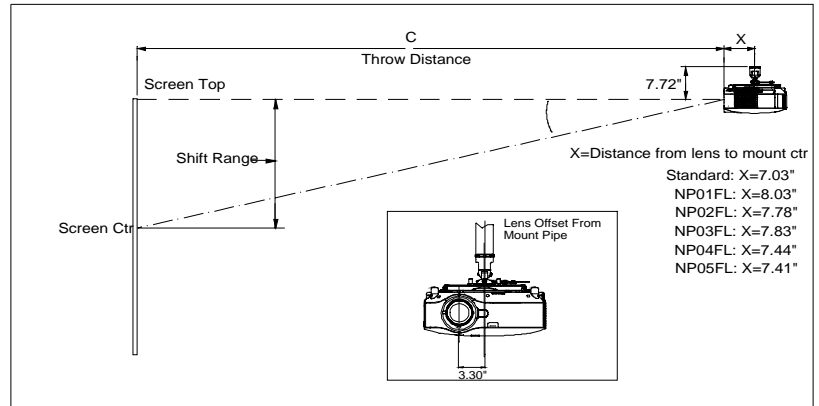

Desktop Installation

Note: Lens shift feature is not available with NP10FL (rear lens) NP10FL should be used only for "zero degree" / "no-offset" applications.

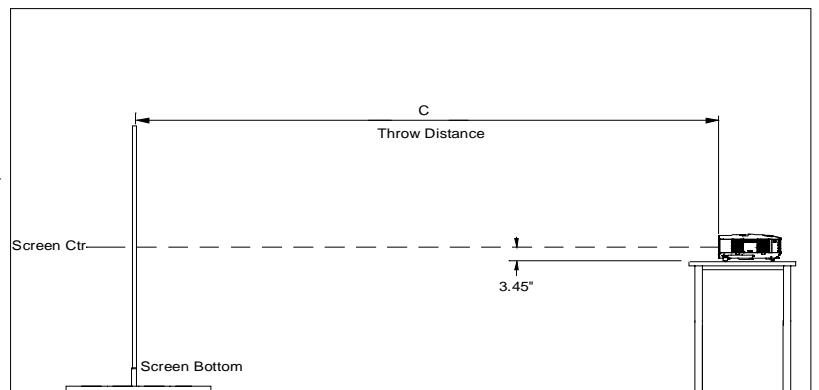

Distance Chart for popular 4:3 screens

Screen Size (4:3)			Rear Lens	Zoom Lenses									
			NP01FL	Standard	NP02ZL		NP03ZL		NP04ZL		NP05ZL		
Diagonal	Width(H)	Height (V)	0.8:1	1.5 - 2.0:1		1.18 - 1.54:1		1.94 - 3.07:1		2.98 - 4.77:1		4.62 - 7.02:1	
inches	inches	inches	inches	inches		inches		inches		inches		inches	
40	32	24	25.38	47.37	63.8	37.3	49.07	61.4	98.6	NA		NA	
60	48	36	38.7	72.11	96.6	56.9	74.5	93.5	149.4	141.7	229.7	NA	NA
67	53.6	40.2	43.3	80.8	108.2	63.7	83.4	104.7	167.1	158.8	257.0	NA	NA
72	57.6	43.2	46.6	86.9	116.4	68.6	89.8	112.8	179.8	171.1	276.6	260.7	415.0
84	67.2	50.4	54.6	101.8	136.1	80.3	105.0	132.0	210.3	200.4	323.5	316.8	485.5
90	72	54	58.6	109.2	146.0	86.2	112.6	141.7	225.5	215.0	346.9	340.0	520.7
100	80	60	65.2	121.6	162.4	95.96	125.4	157.7	250.8	239.5	386.0	378.6	579.4
120	96	72	78.5	146.3	195.3	115.5	150.8	189.8	301.6	288.3	464.2	455.8	696.8
150	120	90	98.46	183.4	244.6	144.8	188.9	238.0	377.7	361.6	581.5	571.7	872.9
180	144	108	NA	220.5	294.0	174.2	227.1	286.2	453.8	434.9	698.7	687.5	1049.0
210	168	126	NA	257.6	343.3	203.5	265.2	334.3	529.9	508.2	816.0	803.4	1225.1
240	192	144	NA	294.7	392.6	232.8	303.4	382.5	606.0	581.5	933.3	919.3	1401.2
270	216	162	NA	331.8	442.0	262.2	341.5	430.7	682.1	654.8	1050.5	1035.1	1577.3
300	240	180	NA	368.9	491.3	291.5	379.7	478.8	758.2	728.1	1167.8	1151.0	1753.5
400	320	240	NA	492.6	655.7	389.2	506.8	639.4	1011.9	972.4	1558.7	1537.2	2340.5
500	400	300	NA	616.30	820.2	487.0	634.0	799.9	1265.6	1216.7	1949.6	1923.4	2927.5

Note: For screen sizes not indicated on the projection tables, use the formulas on page 1.

NP1000/2000 Installation Guide

Desktop and Ceiling Mount

v 1.1

Projection Distance and Screen Size for Ceiling Mount

The following shows the proper relative positions of the projector and screen. Refer to the table to determine the position of installation.

Distances are in inches. For millimeters multiply by 25.4.

Ceiling Mount Installation

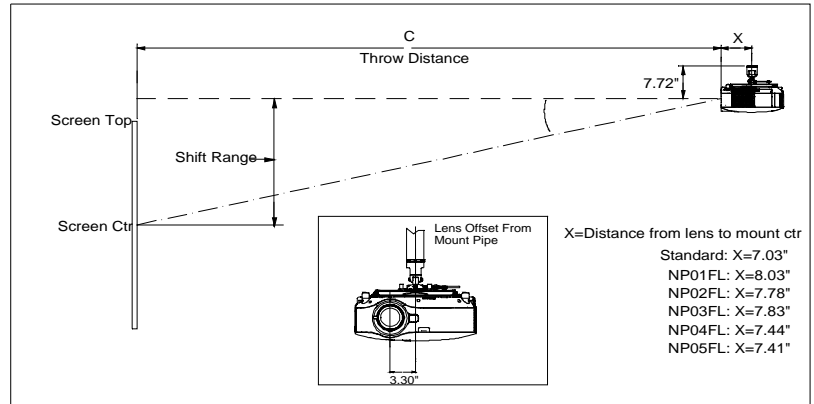

Desktop Installation

Note: Lens shift feature is not available with NP10FL (rear lens) NP10FL should be used only for "zero degree" / "no-offset" applications.

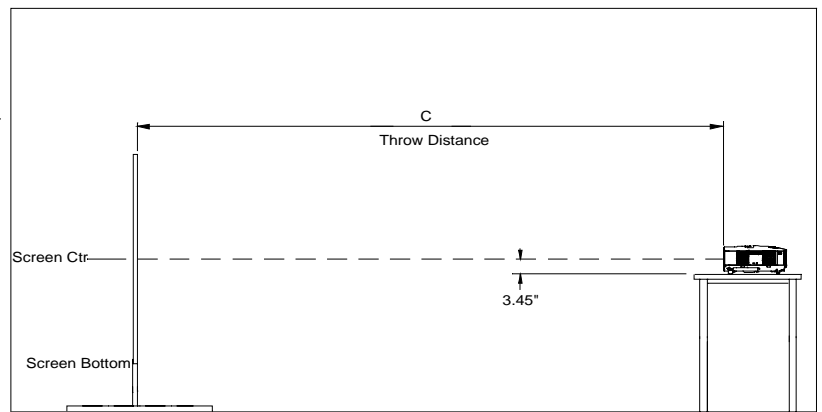

Distance Chart for popular 16:9 screens

Screen Size (16:9)			Zoom Lenses										
			Rear Lens	Standard		NP02ZL		NP03ZL		NP04ZL		NP05ZL	
Diagonal	Width(H)	Height (V)	0.8:1	1.5 - 2.0:1		1.18 - 1.54:1		1.94 - 3.07:1		2.98 - 4.77:1		4.62 - 7.02:1	
inches	inches	inches	inches	inches		inches		inches		inches		inches	
92	80	45	65.24	121.6	- 162.4	96.0	- 125.4	157.7	250.8	239.5	386.0	366.4	579.4
100	87	49	71.1	132.4	- 176.8	104.5	- 136.5	171.8	273.0	260.8	420.2	399.5	630.8
106	92	52	75.2	140.1	- 187.1	110.6	- 144.4	181.8	288.9	276.1	444.7	423.1	667.4
110	96	54	78.5	146.3	- 195.3	115.5	- 150.8	189.8	301.6	288.3	464.2	442.0	696.8
119	104	58.8	85.2	158.7	- 211.8	125.3	- 163.5	205.9	326.9	312.8	503.3	494.4	755.5
123	107	60	87.7	163.3	- 217.9	129.0	- 168.3	211.9	336.5	321.9	518.0	508.9	777.5
133	116	65	95.1	177.2	- 236.4	140.0	- 182.6	230.0	365.0	349.4	561.9	552.4	843.6
135	118	66	96.8	180.3	- 240.5	142.4	- 185.8	234.0	371.3	355.5	571.7	562.0	858.2
159	139	78	NA	212.8	- 283.7	168.1	- 219.1	276.1	437.9	419.6	674.3	663.4	1012.3
161	140	79	NA	214.3	- 285.8	169.3	- 220.7	278.1	441.1	422.7	679.2	668.2	1019.7
229	200	113	NA	307.1	- 409.1	242.6	- 316.1	398.6	631.4	605.9	972.4	957.9	1459.9
275	240	135	NA	368.9	- 491.3	291.5	- 379.7	478.8	758.2	728.1	1167.8	1151.0	1753.5
367	320	180	NA	492.6	- 655.7	389.2	- 506.8	639.4	1011.9	972.4	1558.7	1537.2	2340.5
459	400	225	NA	616.3	- 820.2	487.0	- 634.0	799.9	1265.6	1216.7	1949.6	1923.4	2927.5

Note: For screen sizes not indicated on the projection tables, use the formulas on page 1.

NP1000/2000 Installation Guide

Desktop and Ceiling Mount

v 1.1

Lens Shift Adjustable Range

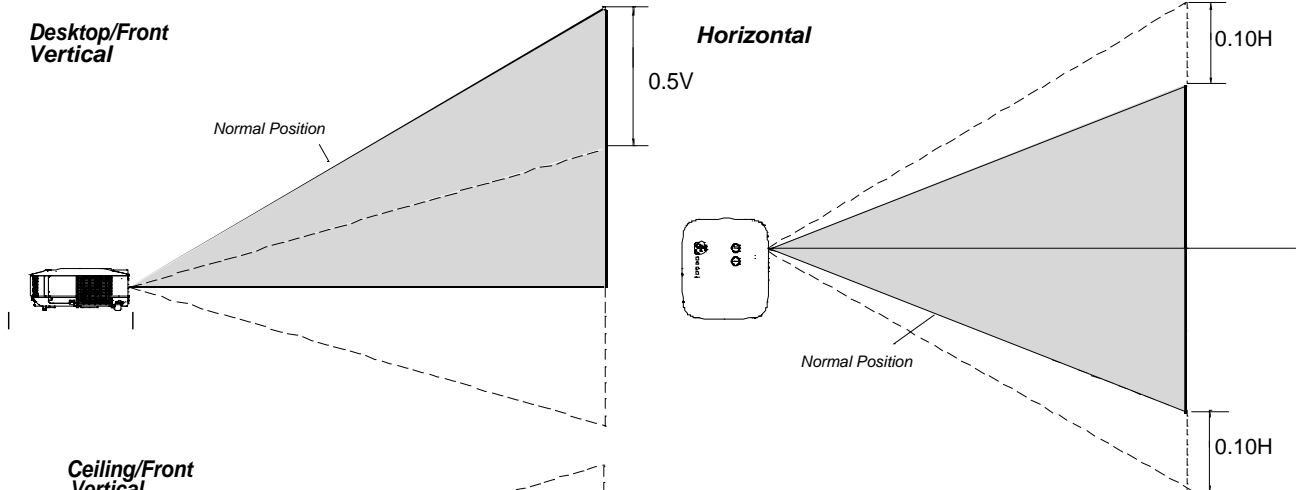

Lens Shift Range for Desktop and Ceiling Mount Application

The diagram below shows the location of the image position in the lens. The lens can be shifted within the shaded area as shown using the normal projection position as a starting point.

Note: Lens shift feature is not available with NP10FL (rear lens). NP10FL should be used only for "zero degree" / "no-offset" applications.

Maximum Possible Range for Standard Lens/NP02ZL/NP03ZL/NP04ZL/NP05ZL:

- Up: 0.5V
 - Right: 0.10H
 - Left: 0.10H
- (H: width of projected image, V: height of projected image)

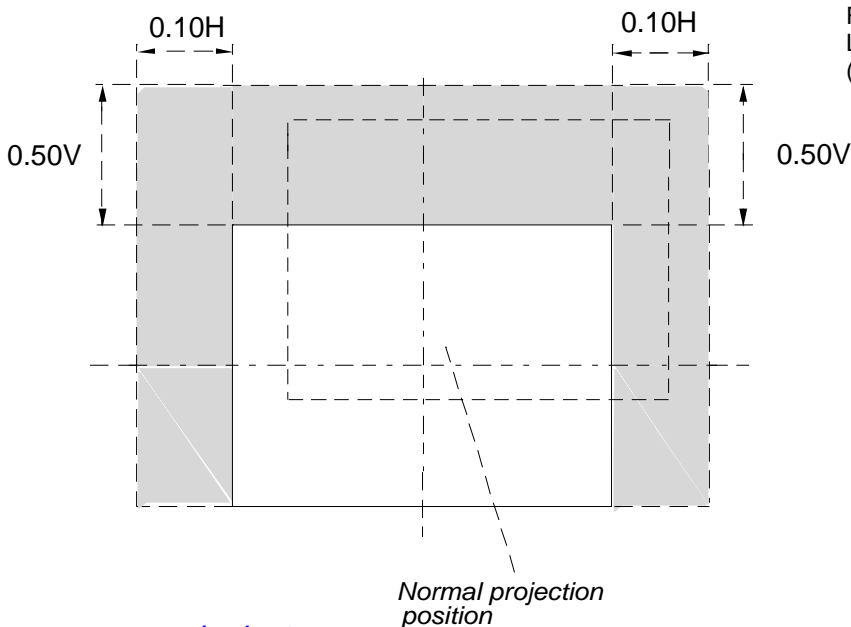

NP1000/2000 Installation Guide

Desktop and Ceiling Mount

v 1.1

Cabinet Dimensions

The following diagrams show the cabinet dimensions for the NP1000/2000. Dimensions are in inches. For millimeters multiply by 25.4.

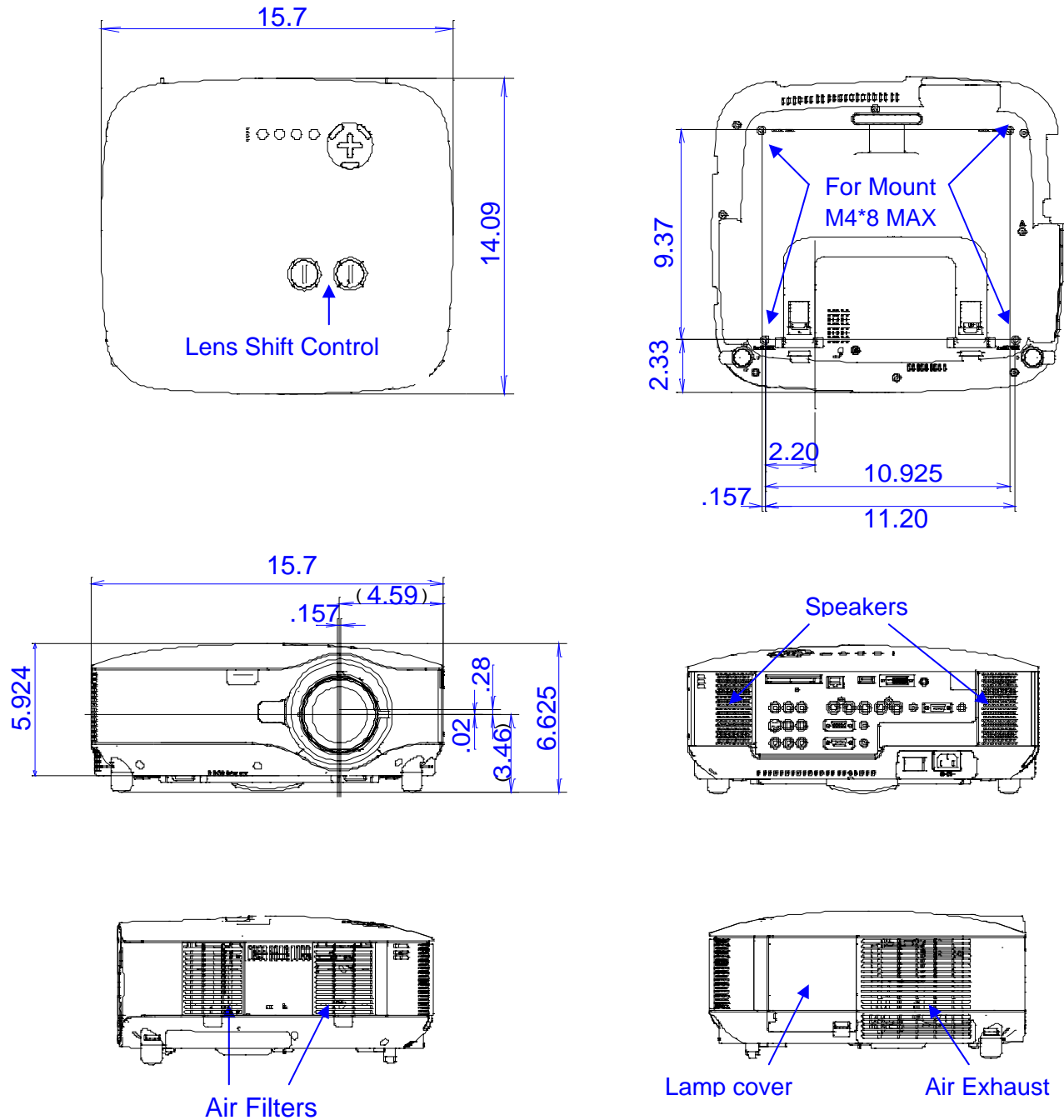

NP1000/2000 Installation Guide

Desktop and Ceiling Mount

v 1.1

Lens Dimensions

The following drawings show the added dimensions for the optional lenses. Dimensions are in inches. For millimeters multiply by 25.4.

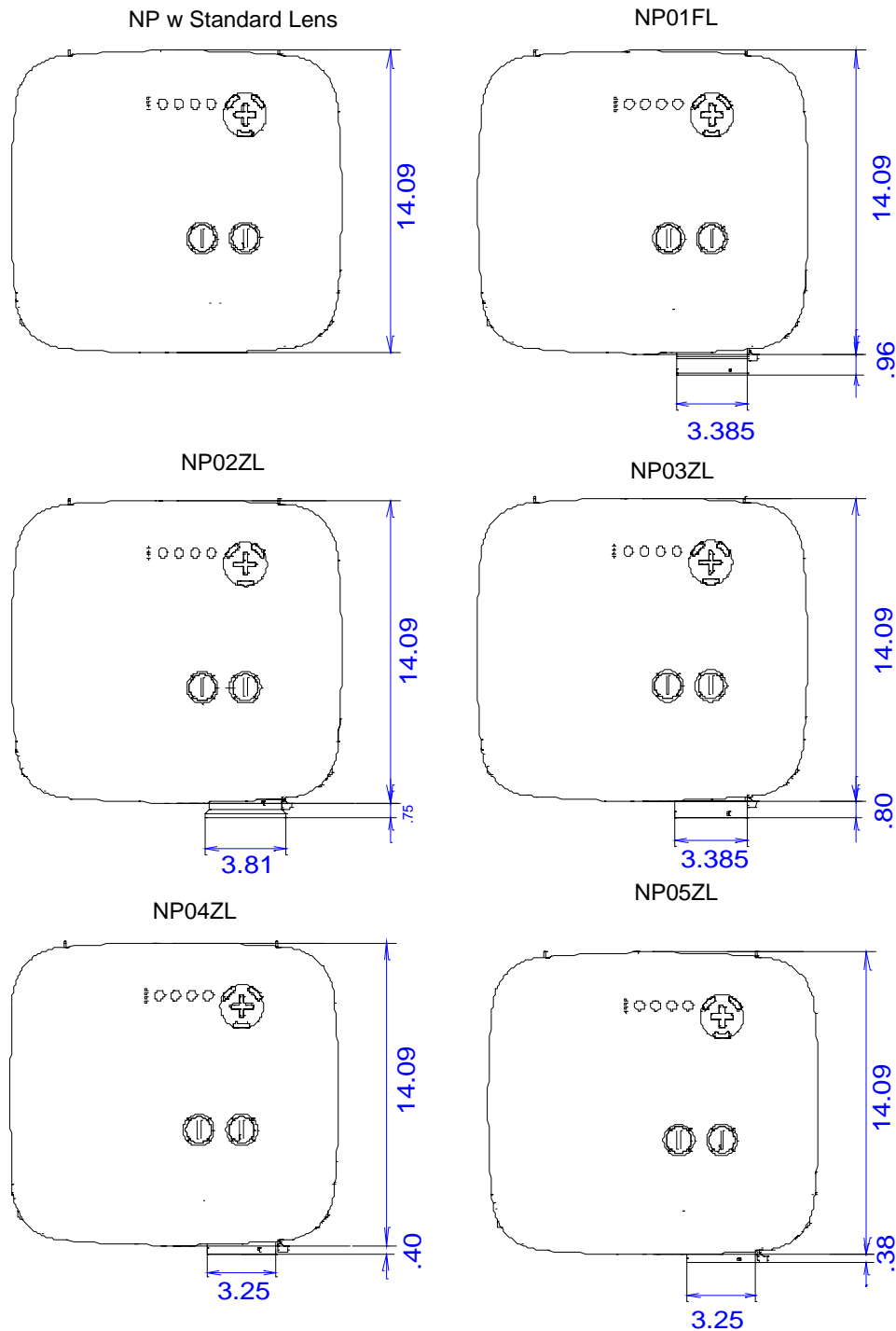

NP1000/2000 Installation Guide

Desktop and Ceiling Mount

v 1.1

Optional Ceiling Mount Dimensions (Model #: NP1000CM)

The following diagrams show ceiling mount dimensions for the NP1000/2000. Dimensions are in inches. For millimeters multiply by 25.4.

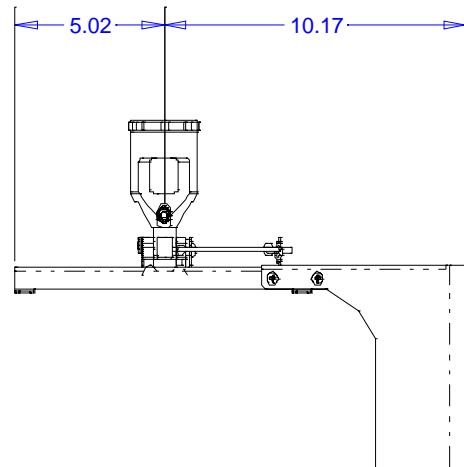
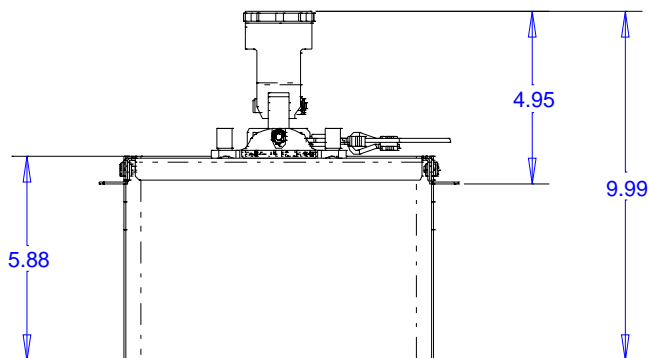
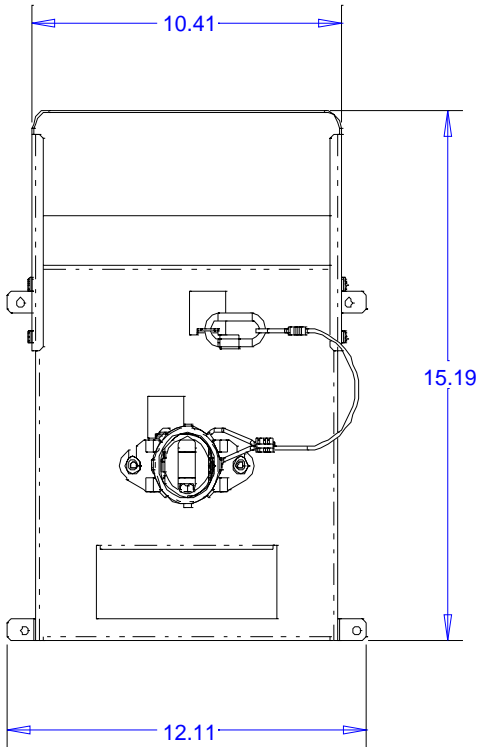
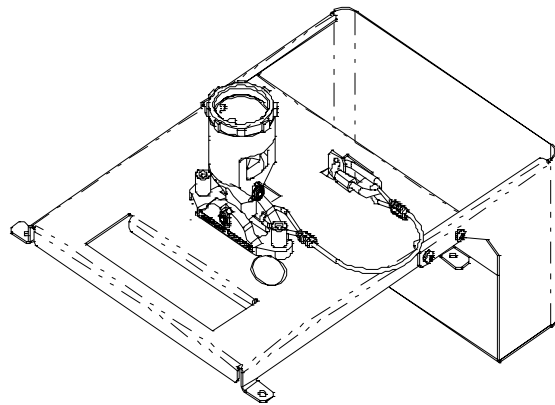
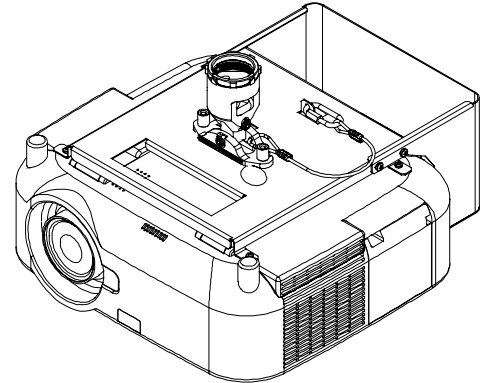

Pole Ceiling Mount with Input Cover

NP1000/2000 Installation Guide

Desktop and Ceiling Mount

v 1.1

Optional Ceiling Mount Dimensions (Model #: NP1000CM) (continued)

The following diagrams show ceiling mount dimensions for the NP1000/2000. Dimensions are in inches. For millimeters multiply by 25.4.

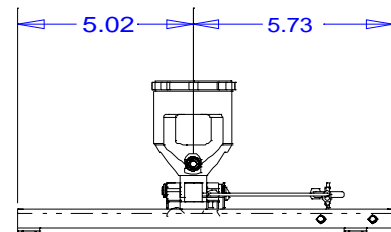
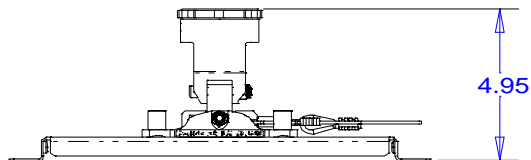
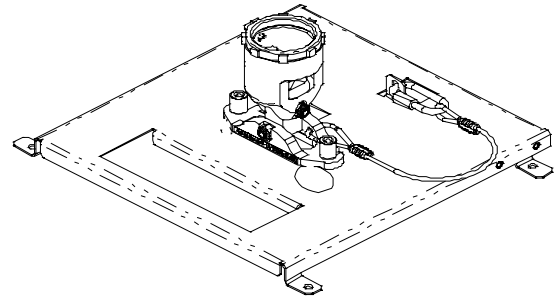
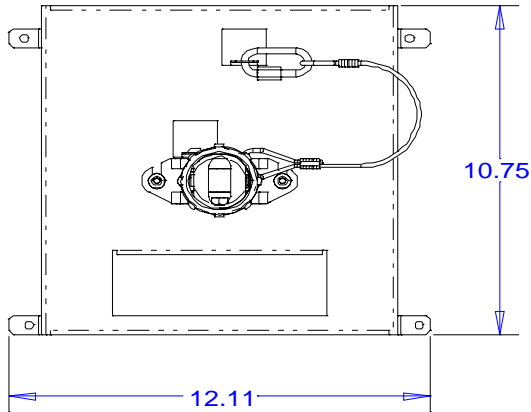

POLE MOUNT W/O I/O COVER

NP1000/2000 Installation Guide

Desktop and Ceiling Mount

v 1.1

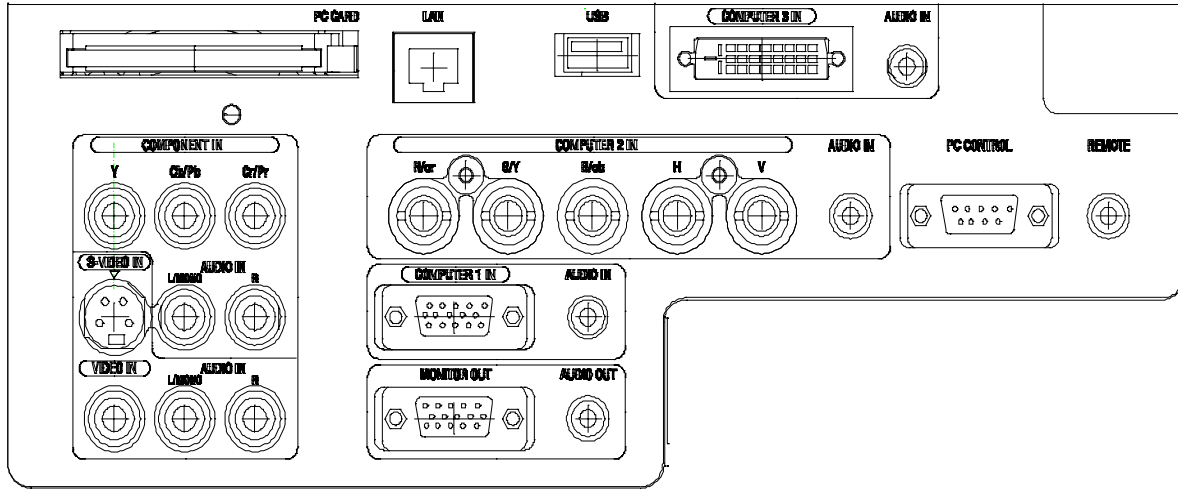

PC Control Codes

Function	Code Data
POWER ON	02H 00H 00H 00H 00H 02H
POWER OFF	02H 01H 00H 00H 00H 03H
INPUT SELECT RGB 1	02H 03H 00H 00H 02H 01H 01H 09H
INPUT SELECT RGB 2	02H 03H 00H 00H 02H 01H 02H 0AH
INPUT SELECT RGB 3	02H 03H 00H 00H 02H 01H 1AH 22H
INPUT SELECT COMPONENT	02H 03H 00H 00H 02H 01H 10H 18H
INPUT SELECT VIDEO	02H 03H 00H 00H 02H 01H 06H 0EH
INPUT SELECT S-VIDEO	02H 03H 00H 00H 02H 01H 0BH 13H
INPUT SELECT PC CARD VIEWER	02H 03H 00H 00H 02H 01H 1FH 27H
INPUT SELECT LAN	02H 03H 00H 00H 02H 01H 20H 28H
PICTURE MUTE ON	02H 10H 00H 00H 00H 12H
PICTURE MUTE OFF	02H 11H 00H 00H 00H 13H
SOUND MUTE ON	02H 12H 00H 00H 00H 14H
SOUND MUTE OFF	02H 13H 00H 00H 00H 15H
ON SCREEN MUTE ON	02H 14H 00H 00H 00H 16H
ON SCREEN MUTE OFF	02H 15H 00H 00H 00H 17H

Cable Connection

Communication Protocol:

- Baud Rate: 38400 bps (for cable lengths longer than 20', it is recommended changing to 9600 bps in setup menu)
- Data Length: 8 bits
- Parity: No Parity
- Stop Bit: One bit
- X on/off: None
- Communications: Full duplex

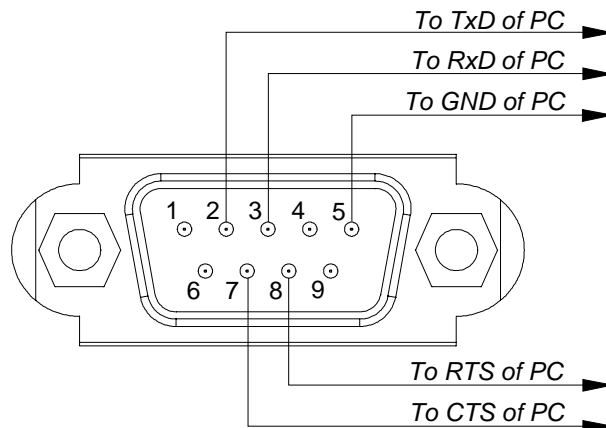

PC Control Connector (D-Sub 9P)

NOTE: Pins 1, 4, 6, and 9 are used inside the projector.

Jumper "Request to send" and "Clear to Send" together on both ends of the cable to simplify cable connection.