

Parts Manual for **SNAPPER**[®]

TWO STAGE LARGE FRAME SNOW THROWER SERIES 5

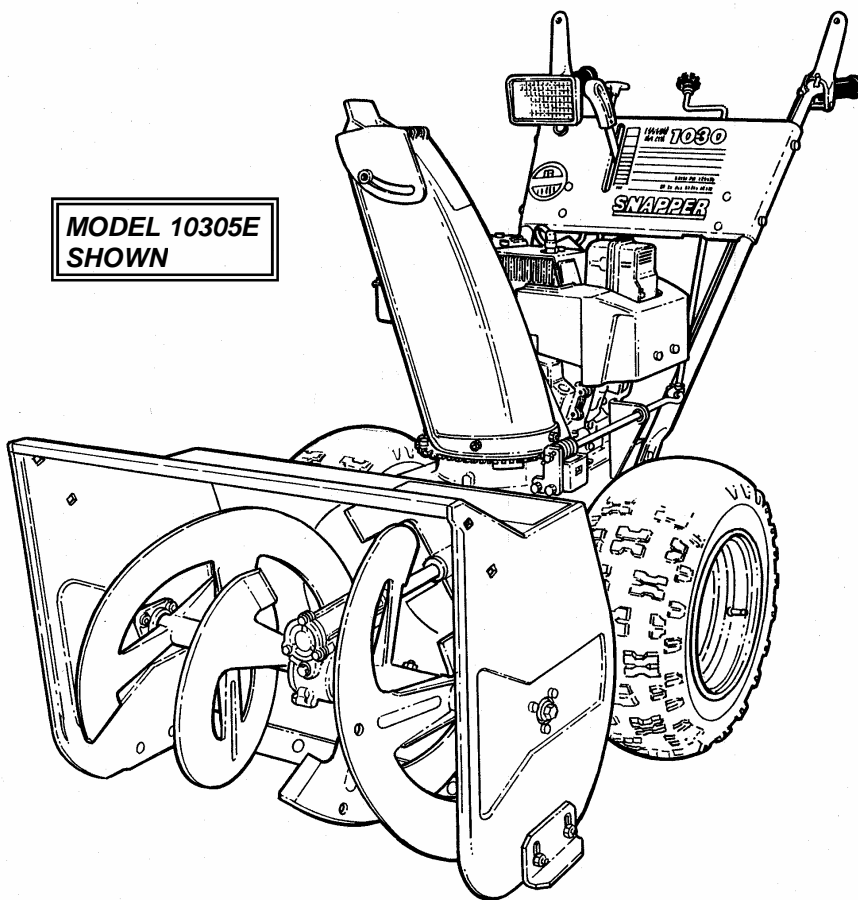

MODEL 10305E
SHOWN

MODELS	
8245	10305
8265	11305
E8265	10305E
9265	E10305
E9265	E10305E
	E11305

IT IS THE POLICY OF SNAPPER TO IMPROVE ITS PRODUCTS WHENEVER IT IS POSSIBLE AND PRACTICAL TO DO SO. WE RESERVE THE RIGHT TO MAKE CHANGES OR ADD IMPROVEMENTS AT ANY TIME WITHOUT INCURRING ANY OBLIGATION TO MAKE SUCH CHANGES ON PRODUCTS MANUFACTURED PREVIOUSLY.

FAMILIARIZATION

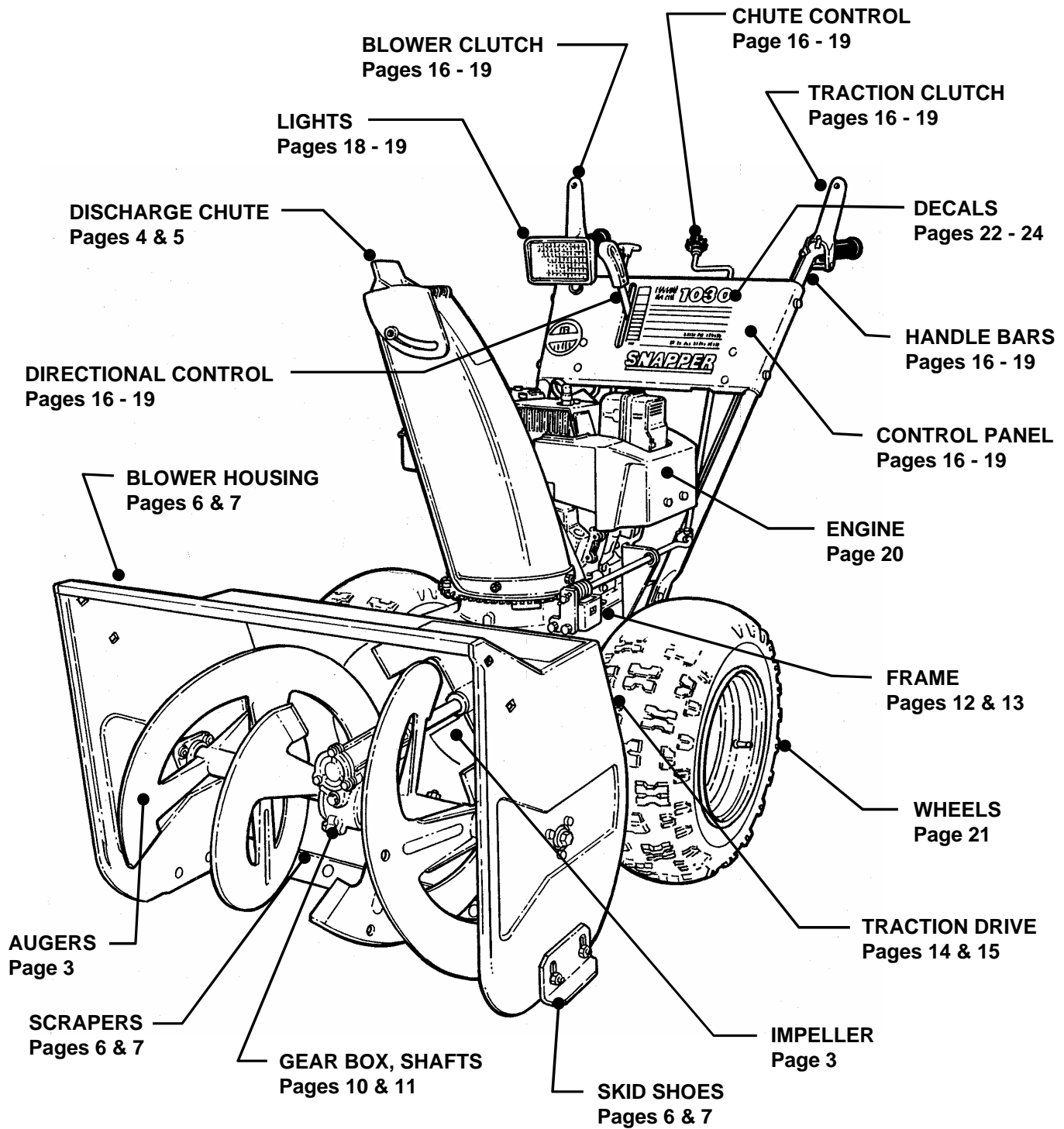

MODEL 10305E SHOWN

**HARDWARE
BAG KITS
PAGE 25**

**ACCESSORIES
PAGE 25 - 27**

AUGERS, IMPELLER

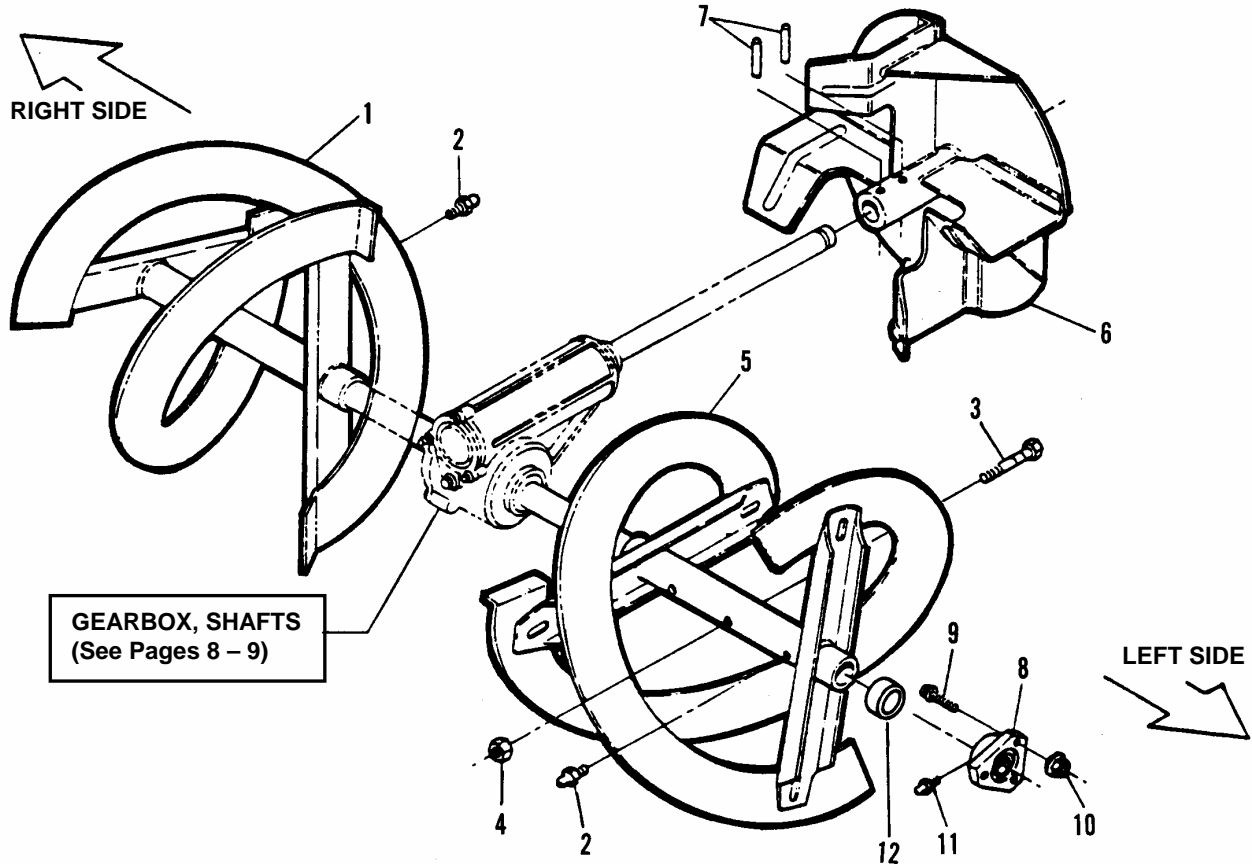

ITEM	PART NO.	DESCRIPTION
1	4-9928	AUGER, Right Side (8245 Models)
-	4-9935	AUGER, Right Side (8265, 9265 & E9265 Models)
-	4-9922	AUGER, Right Side (10305E, E10305E, N10305E, 11305 & E11305 Models)
2	1-3864	FITTING, Grease (2)
3	9-1550	BOLT, 5/16-18 x 1-7/8" Shear (2)
4	9-1298	NUT, 5/16-18 Hex Nyloc (2)
5	4-9927	AUGER, Left Side (8245 Models)
-	4-9936	AUGER, Left Side (8265, 9265 & E9265 Models)
-	4-9921	AUGER, Left Side (10305E, E10305E, N10305E, 11305 & E11305 Models)
6	4-9677	FAN, Impeller
7	1-3862	PIN, 1/4 x 1-1/2" Roll (2)
8	5-1350	ASSEMBLY, Bearing (Includes Item 11)
9	9-0699	BOLT, 1/4-20 x 3/4" Hex Flange Lock, Grade 5 (6)
10	9-1065	NUT, 1/4-20 Hex Flange Lock (6)
11	1-0817	FITTING, Grease (2)
12	2-8221	SPACER (Used on Model 8245 Models Only) (2)

DISCHARGE CHUTE

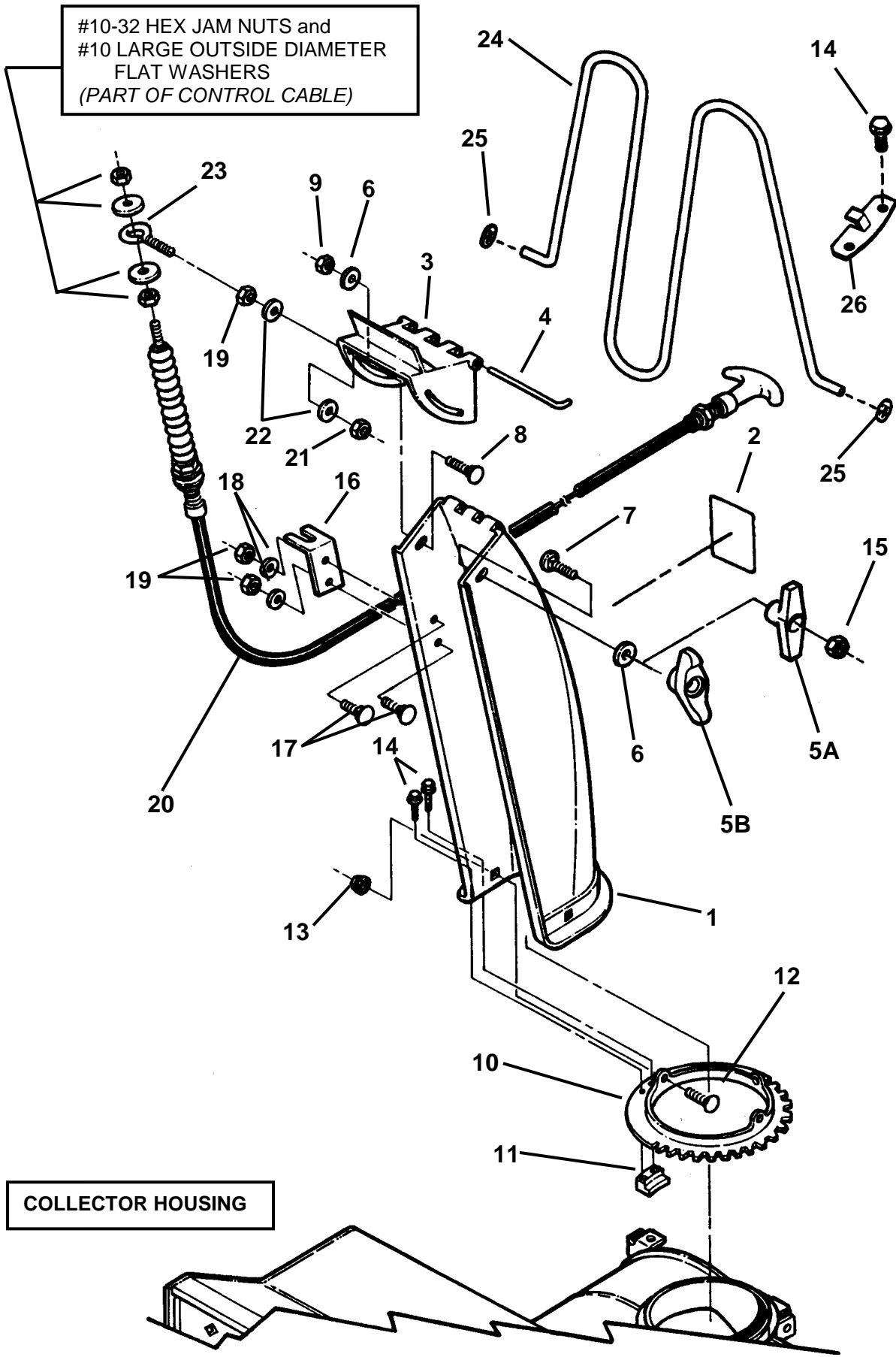

DISCHARGE CHUTE

ITEM	PART NO.	DESCRIPTION
1	2-8208	CHUTE, Discharge
--	2-8217	CHUTE, Remote Control Discharge (8245 Model Only)
2	2-4773	DECAL, Hand Danger
3	2-8235	DEFLECTOR, Remote Control Discharge
--	2-8184	DEFLECTOR (8245 Model Only)
4	2-8253	PIN, Hinge
5A	1-6324	T-KNOB (Plastic)
5B	3-5744	T-KNOB (w/5/16-18 insert)
6	9-1076	WASHER, 5/16 Flat (2)
7	9-1072	BOLT, 5/16-18 x 1" Square Neck Carriage, Grade 5
8	9-1021	SCREW, 5/16-24 x 3/4" Hex Head Cap, Grade 5 (3)
9	9-1074	NUT, 5/16-24 Hex Center Lock, Grade B
10	3-9765	RING, Chute (59 Tooth, 229 Degrees)
--	4-7855	RING, Chute (Euro) (48 Tooth, 187 Degrees)
11	1-1938	RETAINER (Chute Ring to Housing) (2)
12	9-1077	BOLT, 5/16-18 x 5/8" Square Neck Carriage, Grade 5 (3)
13	9-1070	NUT, 5/16-18 Hex Flange Lock, Grade 5 (3)
14	9-1075	SCREW, #10-24 x 5/8" Hex Washer Self-Tap, Grade 5 (8)
15	9-1069	NUT, 5/16-18 Hex, Grade B or 5
16	3-2813	MOUNT, Cable
17	9-1064	BOLT, 1/4-20 x 1/2" Short Neck Carriage, Grade 5 (2)
18	9-1023	WASHER, 1/4" Internal Tooth Lock (2)
19	9-1100	NUT, 1/4-20 Hex (3)
20	4-5172	CABLE, Control
21	9-1099	NUT, 1/4-20 Hex Center Lock, Grade B or 5
22	9-1098	WASHER, 1/4 Flat (2)
23	2-3798	BOLT, 1/4-20 x 1-1/2" Eye
24	1-9692	WIRE, Safety
25	2-3673	PUSH-ON Fastener, 5/32" Dia. (2)
26	3-2559	RETAINER, Safety Wire (2)

COLLECTOR HOUSING

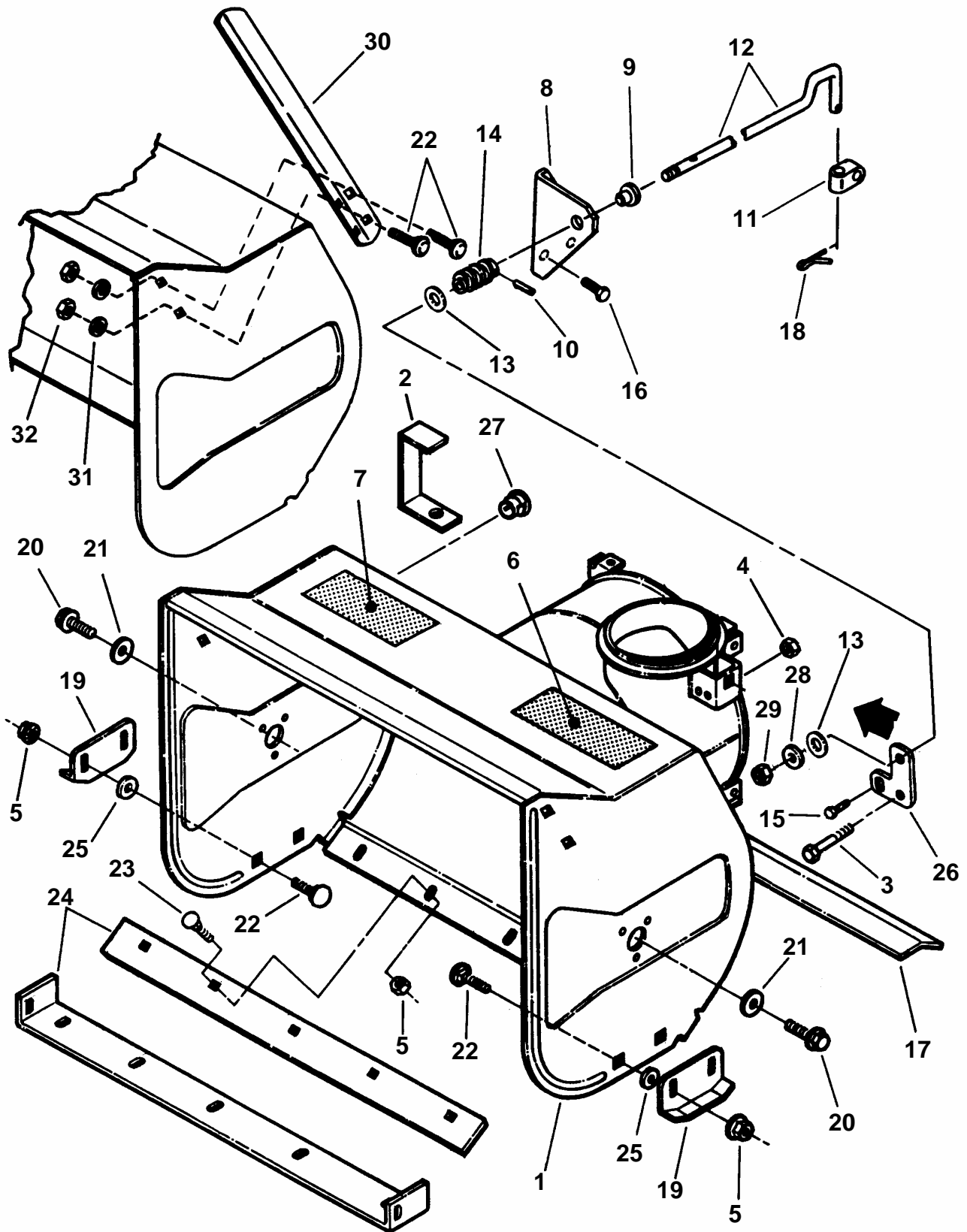

COLLECTOR HOUSING

ITEM	PART NO.	DESCRIPTION
1	5-2134	ASSEMBLY, 24" Blower (8245 Models) (Includes 1-6578 Decal)
--	5-2135	ASSEMBLY, 26" Blower (8265 & 9265 Models) (Incl. 1-6578 Decal)
--	5-3421	ASSEMBLY, 30" Blower (10305E & 11305E Models) (Includes 2-6629 Decal)
2	3-3035	GUIDE, Cable (8265, 9265, E9265, 10305E, E10305E, N10305E), 11305 & E11305)
3	9-1021	SCREW, 5/16-24 x 3/4" Hex Head Cap, Grade 5
4	9-1074	NUT, 5/16-24 Hex Center Lock, Grade B
5	9-1070	NUT, 5/16-18 Hex Flange Lock, Grade 5 (9)
6	2-8280	DECAL, Danger Rotating Auger
--	2-8711	DECAL, Foot Danger (Euro)
7	2-8281	DECAL, Heavy Duty Snow
8	3-4303	BRACKET, Worm Shaft Support
9	1-2117	BUSHING
10	1-4001	PIN, 1/8 x 3/4" Roll
11	2-8222	CONNECTOR
12	4-2809	SHAFT, Worm (3/8-16 threaded)
13	1-1724	WASHER, 13/32 Spring (2)
14	2-8348	WORM
15	9-0539	SCREW, 1/4-20 x 1/2" Hex Washer Self-Tap
16	9-0858	SCREW, 5/16-18 x 1/2" Hex Washer Self-Tap (2)
17	3-8009	BAR, Stiffener (10305E, 11305 & E11305 Models Only)
18	9-1082	PIN, 3/32 x 3/4" Cotter
19	3-7982	SHOE, Skid (2)
20	9-0324	SCREW, 3/8-16 x 1" Hex Washer Self-Tap (2)
21	1-6360	WASHER, 3/8" Flat
22	9-0001	BOLT, 5/16-18 x 3/4" Short Neck Carriage, Grade 5 (11)
23	9-0731	BOLT, 5/16-18 x 1/2" Short Neck Carriage, Grade 5 (5)
24	3-6122	BLADE, Scraper (8245 Models)
--	3-9770	BLADE, Scraper (8265 & 9265 Models)
--	3-6006	BLADE, Scraper (10305E, 11305 & E11305 Models)
25	9-1076	WASHER, 5/16 Flat
26	2-8177	BRACKET, Worm
27	4-2894	PLUG, Dome 5/16" (2)
--	4-2895	PLUG, 5/16" Dome (2)
28	9-1514	WASHER, 3/8" Flat
29	9-1585	NUT, 3/8-16 Hex Center Lock, Grade 5 or B
30	3-7971	DRIFT CUTTER (2)
31	9-0187	WASHER, 5/16 Split Lock (4)
32	9-0196	NUT, 5/16-18 Hex (4)

BELTS, IDLER, DRIVE PLATE, SHEAVE

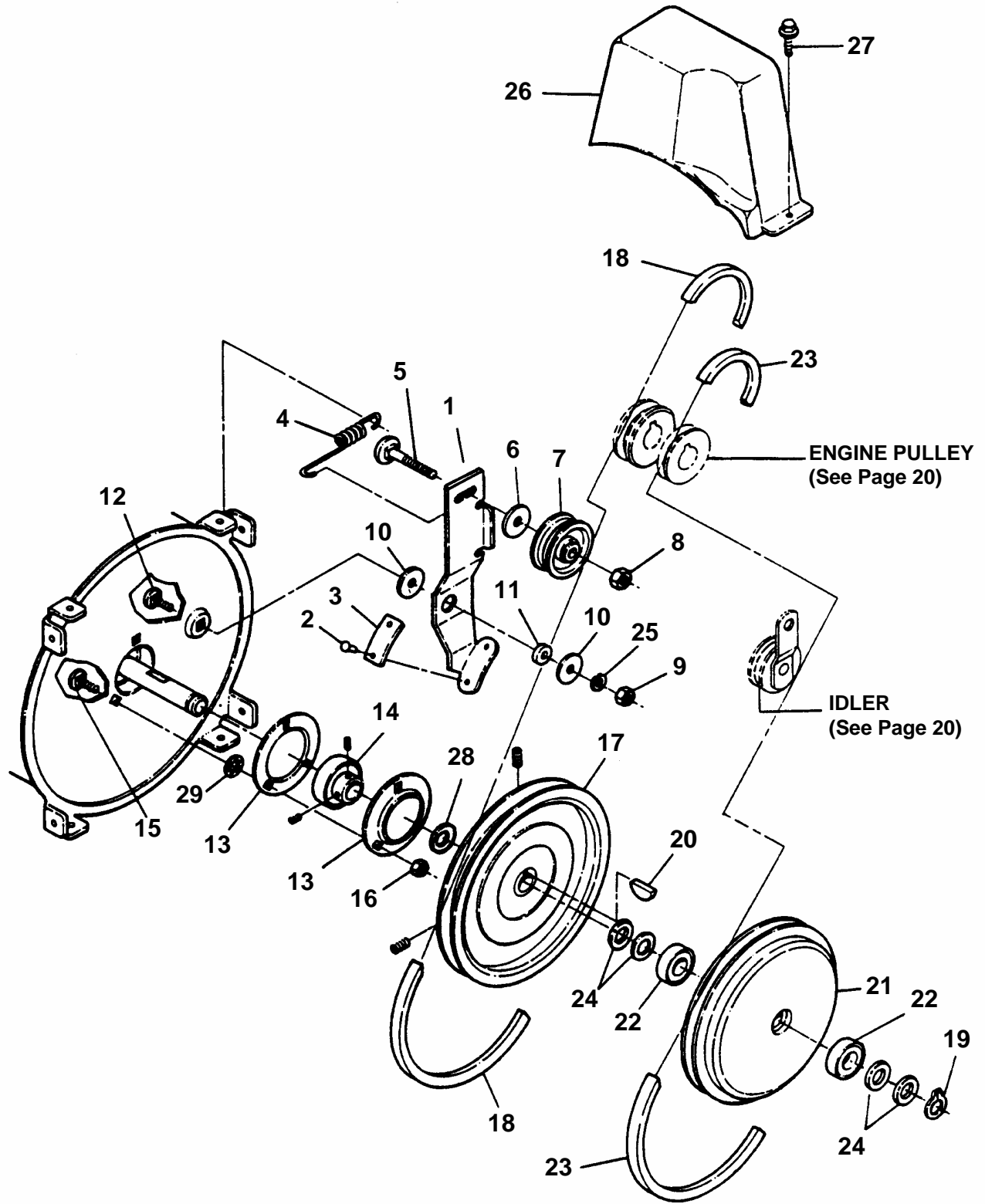

BELTS, IDLER, DRIVE PLATE, SHEAVE

ITEM	PART NO.	DESCRIPTION
1	5-3580	ASSEMBLY, Idler Arm (Includes Items 2 & 3)
2	9-1559	RIVET (2)
3	1-3859	PAD, Brake
4	1-3919	SPRING
5	9-0791	BOLT, 3/8-16 x 1-1/2" Square Neck Carriage, Grade 2
6	9-0122	WASHER, 3/8 Flat
7	1-3850	PULLEY, Idler
8	9-0499	NUT, 3/8-16 Hex Top Lock
9	9-1069	NUT, 5/16-18 Hex, Grade B or 5
10	1-6314	WASHER, 5/16 x 1-1/4" Flat
11	1-3849	SPACER
12	9-1072	BOLT, 5/16-18 x 1" Square Neck Carriage, Grade 5
13	1-3931	HOUSING, Bearing
14	1-3924	BEARING (Includes Two #10-32 Socket Set Screws)
15	9-0001	BOLT, 5/16-18 x 3/4" Short Neck Carriage, Grade 5
16	9-1070	NUT, 5/16-18 Hex Flange Lock, Grade 5 (3)
17	1-3867	SHEAVE, Blower (Includes Two 5/16 Set Screws)
18	1-3937	BELT, Blower (All Models with Briggs Engines)
--	1-3939	BELT, Blower (All Models with Tecumseh Engines)
19	1-0776	RING, 1/2 External Snap (Heavy Duty)
20	1-3861	KEY, #11 Woodruff
21	5-1358	PLATE, Drive (Includes Item 22)
22	1-4295	BEARING, Ball (2)
23	1-3936	BELT, Traction (All Models with Briggs Engines)
--	2-9101	BELT, Traction (All Models with Tecumseh Engines)
24	1-4296	WASHER, 1/2 Shim (4) (Used with Item 21) (4)
25	9-0187	WASHER, 5/16 Split Lock
26	1-7734	COVER, Belt Guard
27	9-1122	SCREW, 1/4-20 x 1/2" Hex Washer Self-Tap
28	3-4302	WASHER, 3/4 x 1-1/8" Flat
29	1-1791	RETAINER, 5/16 Bolt

GEARBOX, SHAFTS

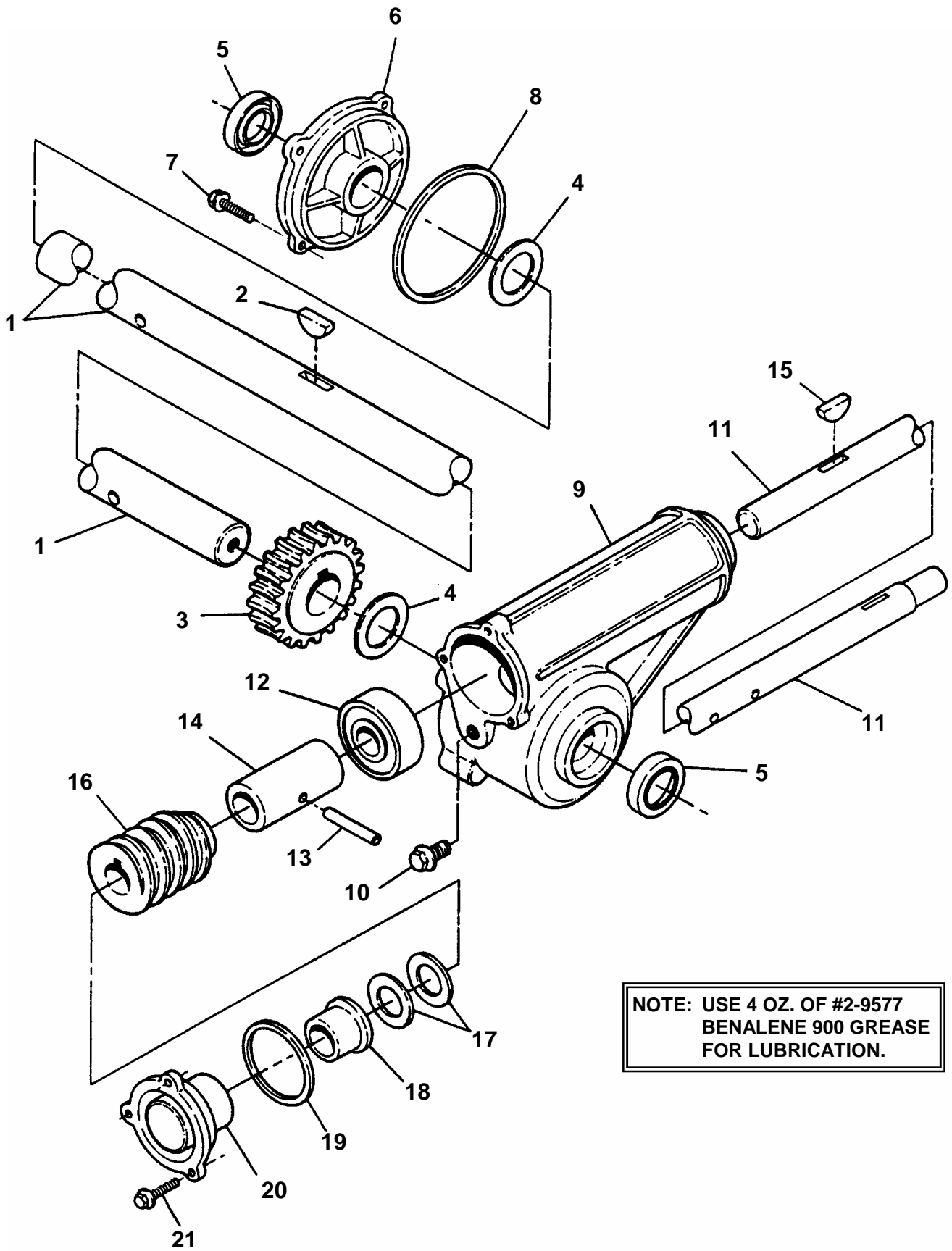

GEARBOX, SHAFTS

ITEM	PART NO.	DESCRIPTION
1*	2-8220	SHAFT, Auger (8245 Models)
-	2-7639	SHAFT, Auger (8265 & 9265 Models)
-	2-9552	SHAFT, Auger (10305E, 11305 & E11305 Models)
2	1-3857	KEY, 1/4 x 7/8" Woodruff
3	5-1305	GEAR, Worm
4	1-3855	WASHER, 1.0 x 1-1/2" Thrust (2)
5	1-3858	SEAL, 1-1/2" O.D. Oil (2)
6	1-8451	COVER, Gear Case
7	9-0290	SCREW, 1/4-20 x 3/4" Hex Washer Self-Tap (4)
8	1-3854	O-RING, Case Cover
9	1-9674	CASE, Gear
10	9-0815	SCREW, 3/8-16 x 1/2" Hex Washer Self-Tap
11	2-7630	SHAFT, Impeller
12	1-3313	BEARING, Impeller Shaft
13	1-3862	PIN, 1/4 x 1-1/2" Roll
14	1-3856	SPACER, Gear Bearing
15	1-3861	KEY, 3/16 x 7/8" Woodruff
16	2-7606	GEAR, Rolled Worm
17	1-0935	WASHER, 3/4 x 1-1/8" Thrust (2)
18	1-2252	BUSHING, Impeller Shaft
19	1-3853	O-RING, Case Cap
20	1-8450	CAP, Case
21	9-1075	SCREW, #10-24 x 5/8" Hex Washer Self-Tap (3)

***NOTE:** The following assemblies are made of items 1 through 21 above:
5-3426, 24" Gear Case Assembly
5-7305, 26" Gear Case Assembly
5-7304, 30" Gear Case Assembly

FRAME, TRACTION DRIVE

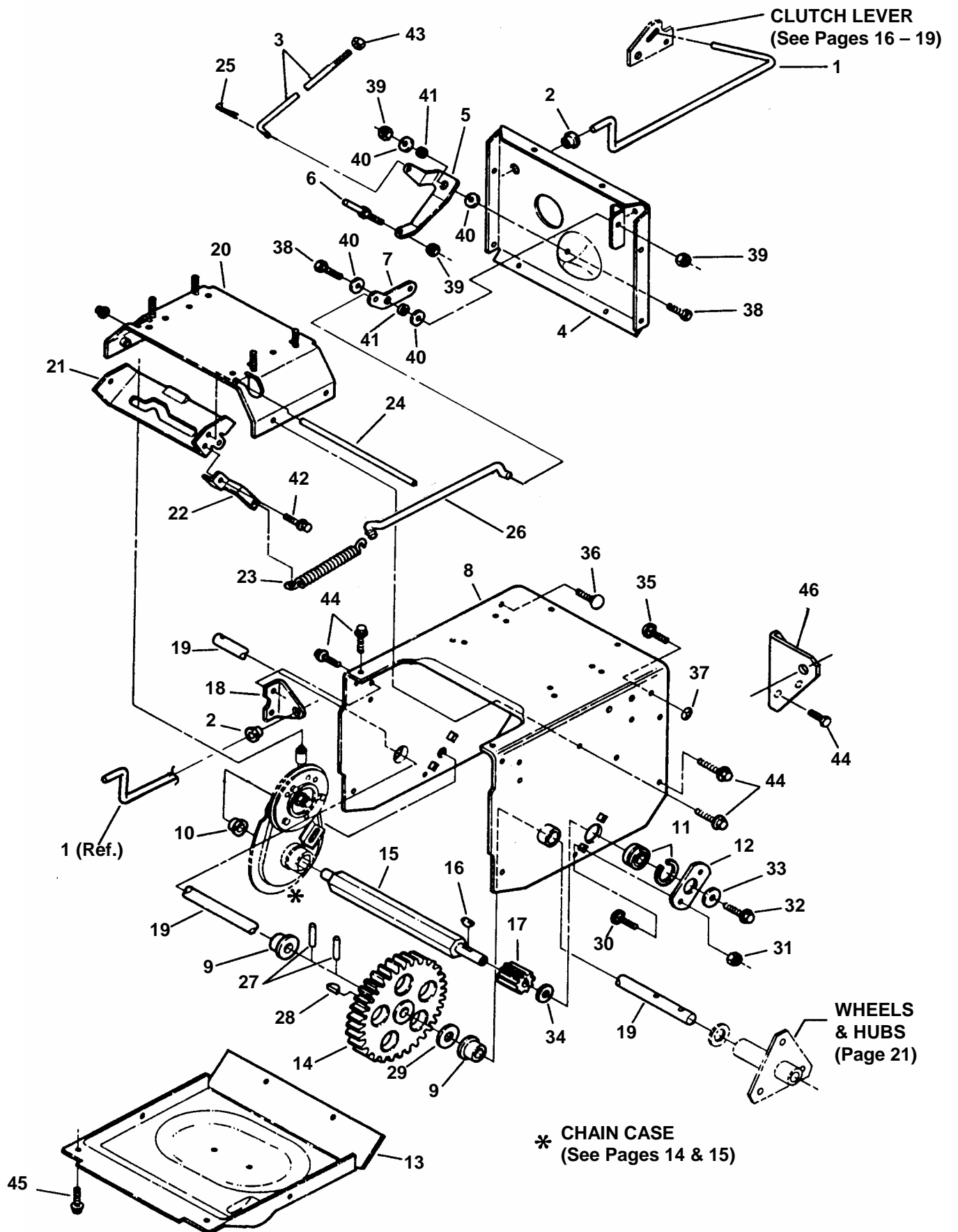

FRAME, TRACTION DRIVE

ITEM	PART NO.	DESCRIPTION
1	1-9684	ROD, Activating
2	1-2117	BUSHING (2)
3	1-3887	ROD, Lower Shift
4	3-9768	COVER, Frame Back
5	3-7967	LEVER, Shift
6	1-3872	STUD, Shift Lever
7	3-2124	BELLCRANK, Traction
8	3-4306	FRAME (Order Items 9 & 10 When Replacing)
9	1-5363	BUSHING, Axle Shaft (2)
10	1-3874	BUSHING, Hex Shaft
11	1-0756	BEARING
12	3-2121	RETAINER, Bearing
13	3-9769	COVER, Frame Bottom
14	1-8460	GEAR, Axle Shaft
15	2-7610	SHAFT, Hex
16	1-0614	KEY, 1/8 x 5/8" Woodruff
17	1-3884	PINION, Hex Shaft
18	3-2120	BRACKET, Idler Mounting
19	2-8209	SHAFT, Axle
20	5-7276	BRACE, Frame (10305E, 11305 & E11305 Models Only)
21	3-7965	BRACKET, Clutch
22	3-2130	BRACKET, Spring
23	1-2264	SPRING
24	2-1843	SHAFT, Cross
25	9-1082	PIN, 3/32 x 3/4" Cotter
26	1-3875	ROD, Push
27	1-3878	PIN, 3/16 x 1-1/4" Roll (2)
28	1-3861	KEY, 3/16 x 7/8" Woodruff
29	3-4302	WASHER, 3/4 x 1-1/8" Flat
30	9-1064	BOLT, 1/4-20 x 1/2" Short Neck Carriage, Grade 5 (2)
31	9-1065	NUT, 1/4-20 Hex Flange Lock
32	9-0858	SCREW, 5/16-18 x 1/2" Hex Washer Self-Tap (3)
33	1-1763	WASHER, 5/16 x 1" Flat
34	1-0690	WASHER, 5/8 Shim
35	9-0001	BOLT, 5/16-18 x 3/4" Short Neck Carriage, Grade 5 (3)
36	9-1612	BOLT, 5/16-18 x 1-1/2" Square Neck Carriage, Grade 5
37	1-1791	RETAINER, 5/16 Bolt (4)
38	9-0206	SCREW, 5/16-18 x 3/4" Hex Head Cap, Grade 2
39	9-1067	NUT, 5/16-18 Hex Center Lock, Grade B (3)
40	1-6314	WASHER, 5/16 x 1-1/4" Flat (4)
41	1-3849	SPACER, 5/16 x 5/8" (2)
42	9-1084	SCREW, 1/4-20 x 3/8" Hex Washer Self-Tap
43	9-1302	NUT, 3/8-16 Hex, Grade B or 5
44	9-0361	SCREW, 5/16-18 x 5/8" Hex Washer Self-Tap (20)
45	9-0362	SCREW, 1/4-20 x 5/8" Hex Washer Self-Tap (4)
46	3-4303	BRACKET, Worm Shaft

CHAIN CASE (TRACTION DRIVE)

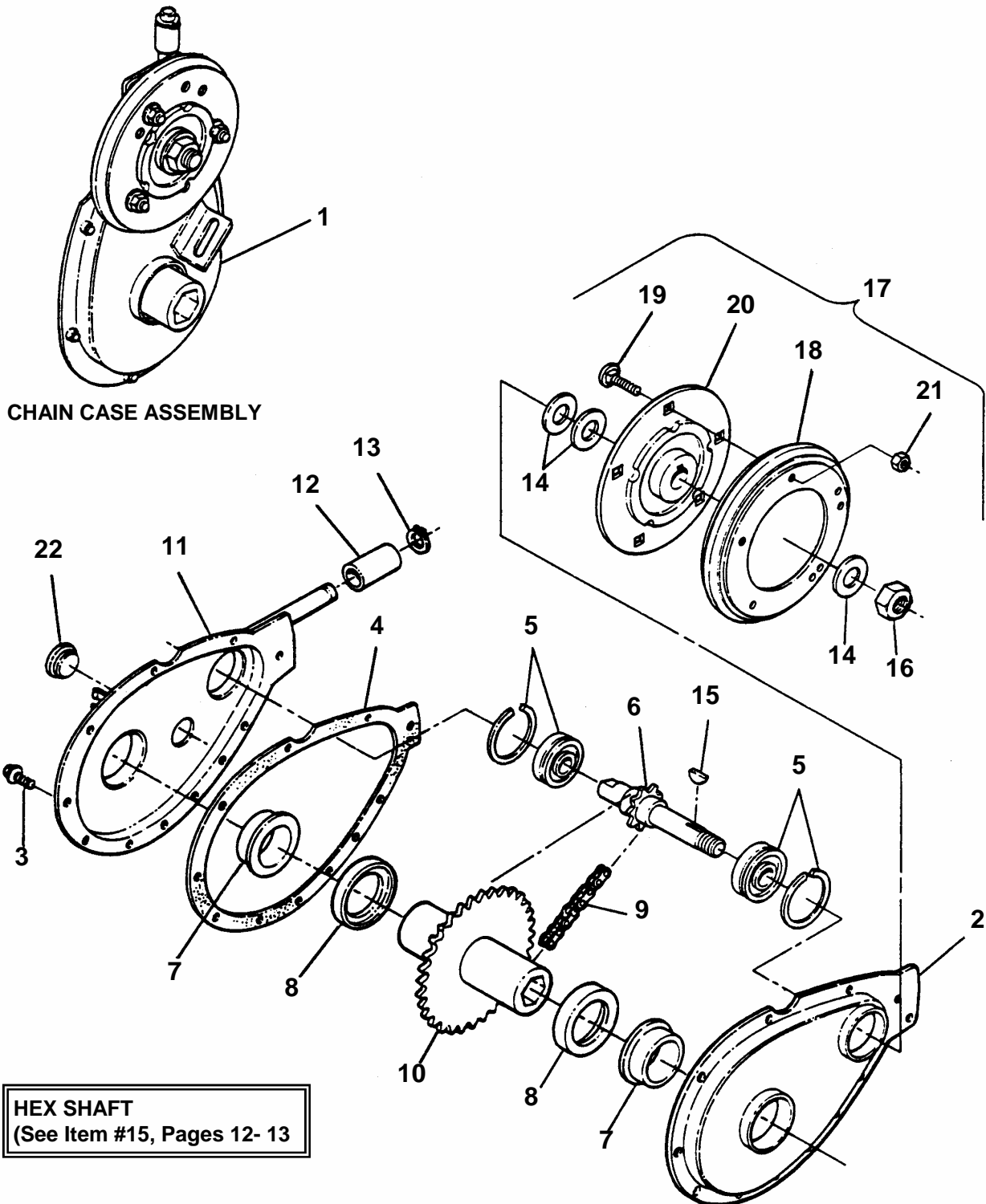

CHAIN CASE ASSEMBLY

HEX SHAFT
(See Item #15, Pages 12- 13)

NOTE: USE "00" GREASE
FOR LUBRICATION

CHAIN CASE (TRACTION DRIVE)

ITEM	PART NO.	DESCRIPTION
1	5-1269	ASSEMBLY, Chain Case (Includes Items 2 Thru 22)
2	3-3543	COVER, Sprocket
3	9-0913	SCREW, #10-24 x 1/2" Hex Washer Self-Tap (Torx)
4	2-8761	GASKET
5	1-0756	BEARING, Ball (2)
6	1-0940	ASSEMBLY, Shaft & Sprocket
7	1-3881	BUSHING (2)
8	1-3882	WASHER, Thrust (2)
9	1-0941	CHAIN
10	4-0465	ASSEMBLY, Hub & Sprocket
11	4-7776	CHASE, Sprocket
12	2-0908	ROLLER
13	1-0776	RING, 1/2" External Snap (Heavy Duty)
14	1-1121	WASHER, Belleville (3)
15	1-0614	KEY, 1/8 x 5/8" Woodruff
16	9-0356	NUT, 5/8-18 Hex Center Lock Jam
17	5-0614	ASSEMBLY, Drive Disc (Includes Items 18 Thru 22)
18	1-0765	DISC, Drive
19	9-0731	BOLT, 5/16-18 x 1/2" Short Neck Carriage, Grade 5 (3)
20	2-0911	HUB
21	9-0585	NUT, 5/16-18 Hex Flange Lock, Grade 5 (3)
22	1-1024	PLUG

HANDLES, CONTROLS (MODELS 8245)

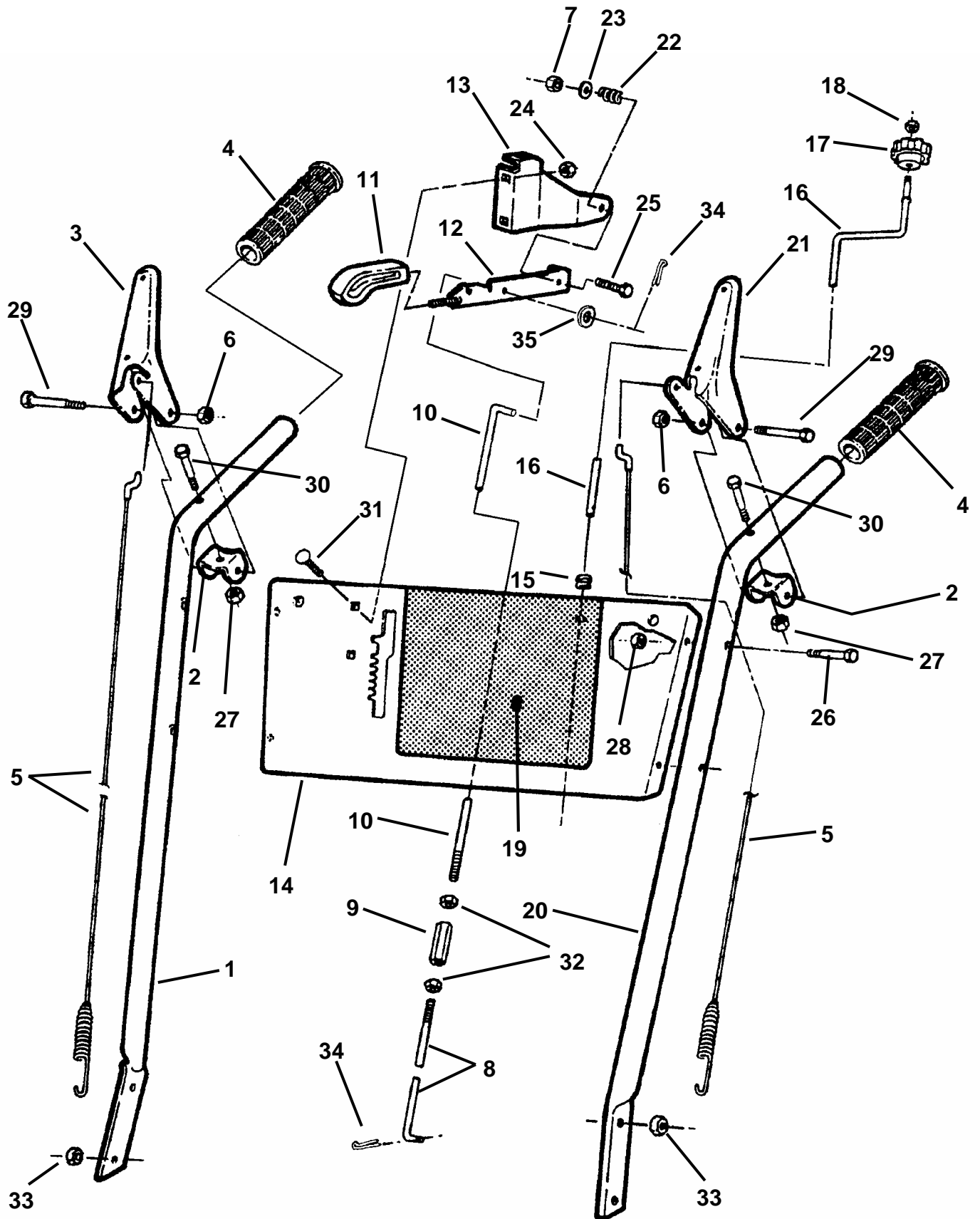

HANDLES, CONTROLS (MODELS 8245)

ITEM	PART NO.	DESCRIPTION
1	3-2922	BAR, Right Side Handle
2	3-2921	BRACKET, Handle (2)
3	3-2908	HANDLE, Right Side
4	2-8189	GRIP, Handle (2)
5	2-8223	CABLE, Clutch (2) (Includes Chain & Spring)
6	9-1020	NUT, 1/4 Push (2)
7	9-1074	NUT, 5/16-24 Hex Center Lock, Grade B
8	1-3887	ROD, Lower Shift
9	1-6304	CONNECTOR
10	1-4297	ROD, Upper Shift
11	1-6334	KNOB, Shift Handle
12	4-0660	HANDLE, Shift
13	3-7962	BRACKET, Shift Lever
14	3-4305	PANEL, Control
15	1-2117	BUSHING
16	2-8215	CRANK, Chute
17	1-3901	KNOB, Chute Crank
18	9-1067	NUT, 5/16-18 Hex Center Lock, Grade B (4)
19	2-8214	DECAL, Control- 8/24
--	4-5177	DECAL, Control- 9/26
--	4-5183	DECAL, Control- E9/26
20	3-2923	BAR, Left Side Handle
21	3-2907	HANDLE, Left Side
22	2-3933	SPRING, Shift Lever
23	9-1076	WASHER, 5/16 Flat
24	9-1065	NUT, 1/4-20 Hex Flange Lock (3)
25	9-0244	SCREW, 5/16-24 x 1-3/4" Hex Head Cap, Grade 2
26	9-1066	SCREW, 5/16-18 x 1-1/2" Hex Head Cap, Grade 5 (4)
27	9-0303	NUT, 1/4-28 Hex Top Lock (2)
28	9-1067	NUT, 5/16-18 Hex Center Lock, Grade B
29	1-6297	PIN, 1/4 x 1-7/8" Clevis
30	9-1025	SCREW, 1/4-28 x 1-3/8" Hex Head Cap, Grade 5 (2)
31	9-1064	BOLT, 1/4-20 x 1/2" Short Neck Carriage, Grade 5 (3)
32	9-1071	NUT, 3/8-16 Hex, Grade B
33	9-1070	NUT, 5/16-18 Hex Flange Lock, Grade 5 (4)
34	9-0041	PIN, 1/8 x 1" Cotter
35	9-1149	WASHER, 3/8 Flat

(NOTE: See Pages 18 Thru 19 for Models 8265, 9265 & 10305E)

HANDLE, CONTROLS (8265, 9265, 10305E, 11305 & E11305 MODELS)

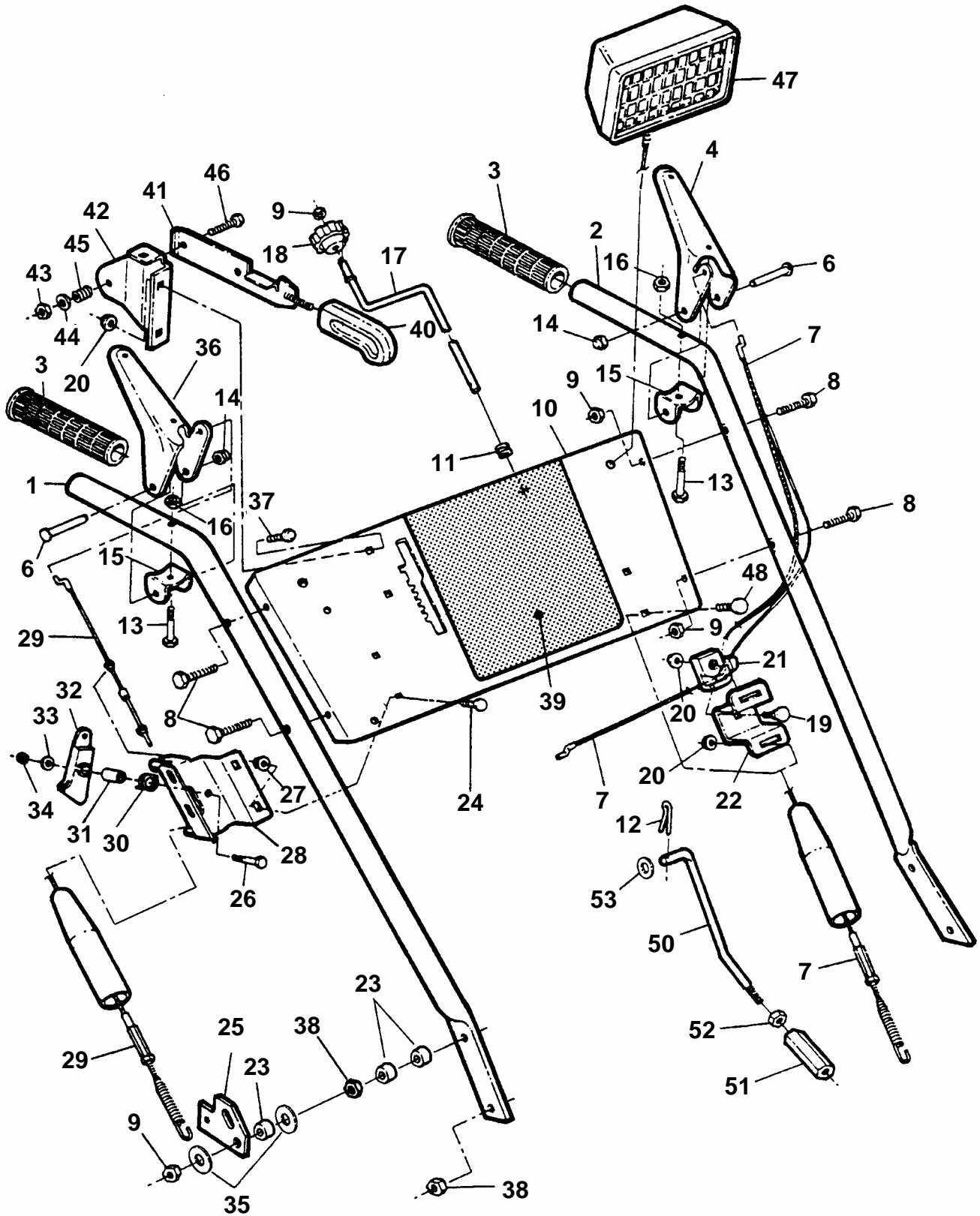

HANDLE, CONTROLS (8265, 9265, 10305E, 11305 & E11305 MODELS)

ITEM	PART NO.	DESCRIPTION
1	3-2922	BAR, Handle (Right Side)
2	3-2923	BAR, Handle (Left Side)
3	1-1870	GRIP, Handle (2)
4	3-2907	HANDLE, Left Side
5	1-6573	DECAL, Traction Clutch
6	1-6297	PIN, 1/4 x 1-7/8" Clevis (2)
7	1-6311	CABLE, Left Side Clutch
8	9-1066	SCREW, 5/16-18 x 1-1/2" Hex Head Cap, Grade 5 (4)
9	9-1067	NUT, 5/16-18 Hex Center Lock, Grade B (5)
10	3-3006	PANEL, Control
11	1-2117	BUSHING
12	9-0041	PIN, 1/8 x 1" Cotter
13	9-1025	SCREW, 1/4-28 x 1-3/8" Hex Head Cap, Grade 5 (2)
14	9-1020	NUT, 1/4 Push (2)
15	3-2921	BRACKET, Handle (2)
16	9-0303	NUT, 1/4-28 Hex Top Lock (2)
17	2-8215	CRANK, Chute
18	1-3901	KNOB, Chute Crank
19	9-0074	BOLT, 1/4-20 x 3/4" Short Neck Carriage, Grade 5 (2)
20	9-1065	NUT, 1/4-20 Hex Flange Lock (3)
21	1-5960	GUIDE, Cable
22	3-2651	BRACKET, Cable Guide Support
23	1-3849	SPACER, 5/16" (3)
24	9-1085	BOLT, #10-24 x 1/2" Flat Head Carriage (2)
25	3-2910	LEVER, Clutch
26	9-0548	SCREW, 1/4-20 x 1" Hex Head Cap, Grade 5
27	9-0623	NUT, #10-24 Hex Flange Lock (2)
28	3-8352	BRACKET, Cam
29	1-6310	CABLE, Auger (Right Side)
30	1-5966	SPRING Cam Lock
31	1-5969	SPACER
32	1-8980	LOCK, Cam
33	9-0055	WASHER, 1/4 Flat
34	9-1099	NUT, 1/4-20 Hex Center Lock, Grade B or 5
35	1-6314	WASHER, 5/16 x 1-1/4" Flat (3)
36	3-2908	HANDLE, Right Side
37	9-1064	BOLT, 1/4-20 x 1/2" Short Neck Carriage, Grade 5 (2)
38	9-1070	NUT, 5/16-18 Hex Flange Lock, Grade 5 (4)
39	2-8278	DECAL, Instruction 8265
--	4-5177	DECAL, Instruction 9265
--	4-5183	DECAL, Instruction E9265
--	2-8279	DECAL, Instruction 10305E
--	2-8695	DECAL, Instruction E10305E & N10305E
--	7-3483	DECAL, Instruction 11305
--	7-3482	DECAL, Instruction E11305
40	1-6334	KNOB, Shift Handle
41	4-0660	WELDMENT, Shift Handle
42	3-7962	BRACKET, Shift Lever
43	9-1074	NUT, 5/16-24 Hex Center Lock, Grade B
44	9-1076	WASHER, 5/16" Flat
45	2-3933	SPRING
46	9-0244	SCREW, 5/16-24 x 1-3/4" Hex Head Cap, Grade 5
47	6-1191	KIT, Light Assembly (Rectangular) (2)
48	9-1064	BOLT, 1/4-20 x 1/2" Short Neck Carriage, Grade 5 (2)
49	1-4940	TIE, Cable
50	1-6312	ROD, Upper Shift
51	1-6304	NUT, 3/8-16 x 1-13/16 Connector
52	9-1071	NUT, 3/8-16 Hex, Grade B
53	9-1149	WASHER, 3/8 Flat

**NOTE: See Pages 16 Thru 17
For Models 8245.**

ENGINES, PULLEY, IDLER

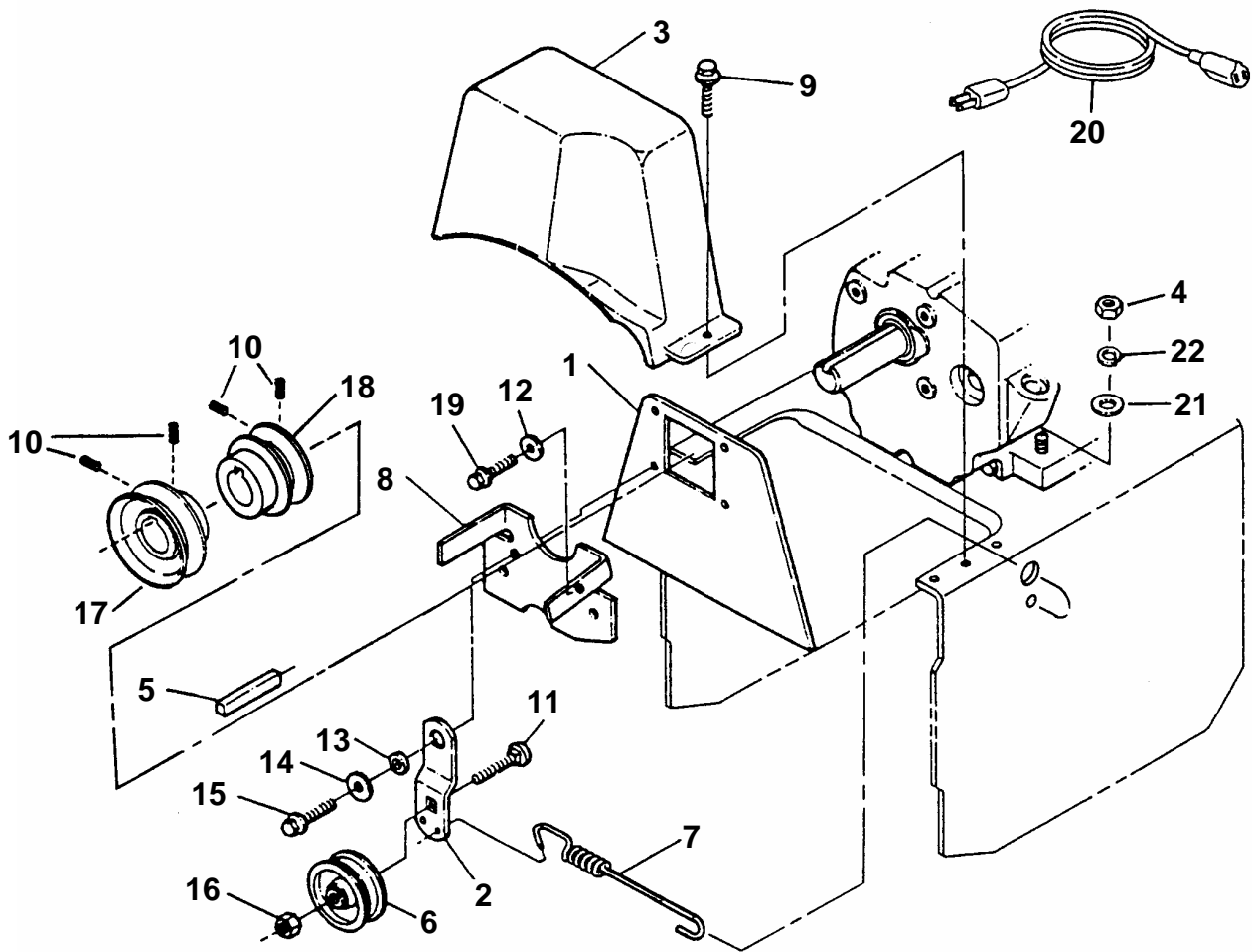

ENGINE SPECS	used on:
8 HP Tecumseh Model HMSK80 Type 155527V.....	8245, 8265 & E8265
9 HP Tecumseh Model HMSK90 Type 156519D.....	9265 & E9265
10 HP Tecumseh Model HMSK100 Type 159236W.....	10305E & E10305E
Type 159302W.....	N10305E
Type 159426W	10305 & E10305
11 HP Tecumseh Model OHSK110 Type 221721B.....	11305 & E11305

ITEM	P/N	DESCRIPTION
1	3-8545	GUARD, Engine
2	3-2128	ARM, Idler
3	1-7734	COVER, Belt
4	9-0196	NUT, 5/16-18 Hex, Grade B or 5 (4)
5	1-0210	KEY, 1/4 x 2" Square
6	1-3850	IDLER
7	2-8212	SPRING, Idler
8	3-2150	FINGER, Belt
9	9-1122	SCREW, 1/4-20 x 1/2" Hex Washer Self-Tap (2)
10	9-0954	SCREW, 5/16-18 x 5/16" Socket Head Set (4)
11	9-0791	BOLT, 3/8-16 x 1-1/2" Square Neck Carriage, Grade 2
12	9-1076	WASHER, 5/16 Flat (5)
13	1-3849	SPACER
14	1-6314	WASHER, 3/8 Flat
15	9-1273	SCREW, 5/16-24 x 7/8" Hex Head Cap, Grade 5
16	9-0499	NUT, 3/8-16 Hex Top Lock
17	1-5376	PULLEY, Blower
18	1-5377	PULLEY, Traction
19	9-1021	SCREW, 5/16-24 x 3/4" Hex Head Cap, Grade 5
20	1-5368	CORD, 10' Extension for 110V (10305 & 10305E Models Only)(Tecumseh Part Number 1A174-17)
--	7-2611	CORD, 8' Extension for 230V (E9265 & E10305 Models)
21	9-1076	WASHER, 5/16 Flat (4)
22	9-0187	WASHER, 5/16 Split Lock (4)
23	2-8747	MUFFLER GUARD, Tecumseh 8 & 10 HP (not shown) (Tecumseh Part Number 127-20)

WHEELS, HUB

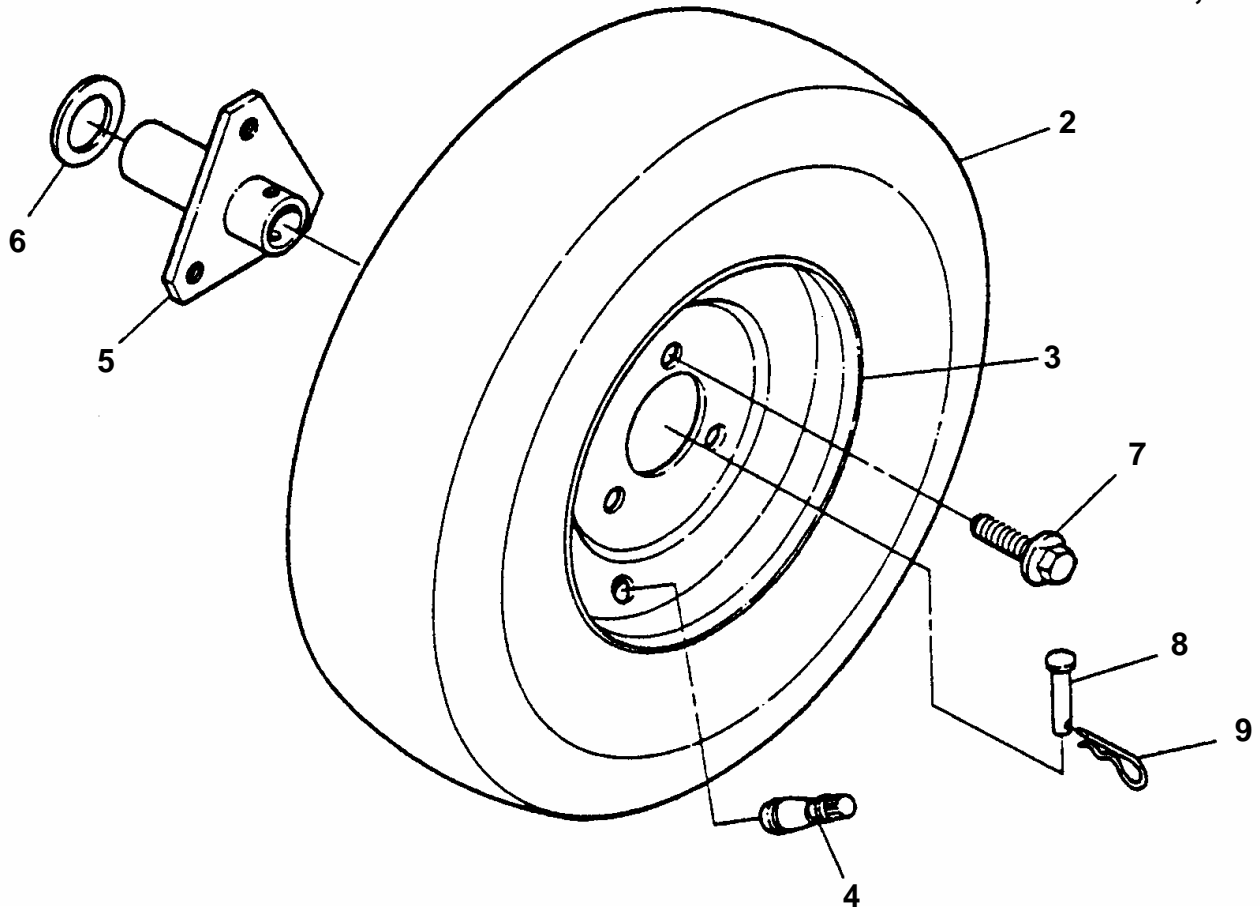

ITEM	PART NO.	DESCRIPTION
1	5-1803	ASSEMBLY, Wheel & Tire (Snow Hog) (8245, 8265, & 9265 Models) (Includes Items 2A, 3A, & 4)
-	5-1871	ASSEMBLY, Wheel & Tire (Snow Hog) (10305E Models) (Includes Items 2B, 3B, & 4)
-	5-8916*	ASSEMBLY, Wheel & Tire (Kenda) (8245, 9265 & E9265 Models) (Includes Items 2C, 3C & 4)
-	5-8918*	ASSEMBLY, Wheel & Tire (Kenda) (11305 & E11305 Models) (Includes Items 2D, 3B & 4)
2A	2-3495	TIRE, 16 x 4.80 x 8 (Snow Hog) (8245, 8265 & 9265 Models)
2B	2-3672	TIRE, 16 x 6.50 x 8 (Snow Hog) (10305E Models)
2C	7-3453	TIRE, 16 x 4.80 x 8 (Kenda) (8245, 9265 & E9265 Models)
2D	7-3455	TIRE, 16 x 6.50 x 8 (Kenda) (11305 & E11305 Models)
3A	1-2162	RIM, (8245, 8265 & 9265 Models)
3B	1-2163	RIM, (10305E, 11305 & E11305 Models)
3C	1-2162	RIM, (8245, 9265 & E9265 Models)
4	1-2234	VALVE, Snap-In
5	4-0464	HUB, Wheel (2)
6	1-0935	WASHER, 3/4 x 1-1/8" Thrust
7	9-1502	BOLT, 1/2-20 x 3/4" Hex Head Lug (Nyloc) Grade 5 (6)
8	1-2407	PIN, 5/16 x 1-11/16" Clevis (2)
9	1-5067	PIN, 3/32 x 1-1/2" Hair (2)

***NOTE: These wheel assemblies are used on units built in 2000 for model year 2001**

DECALS



ITEM	PART NO.	DESCRIPTION
1	2-9776	DECAL, European Community (CE)
2	7-2820	DECAL, 2000 Year of Manufacture
--	7-2404	DECAL, 1999 Year of Mfr.(not shown)
--	3-6434	DECAL, 1997 Year of Mfr.(not shown)
--	2-9077	DECAL, 1996 Year of Mfr.(not shown)
3	2-8280	DECAL, Foot Danger/Blank
4	2-6629	DECAL, Foot Danger/Blank
5	1-6578	DECAL, Danger (Collector)
6	2-7733	DECAL, Ear Protection
7	2-4773	DECAL, Hand Danger

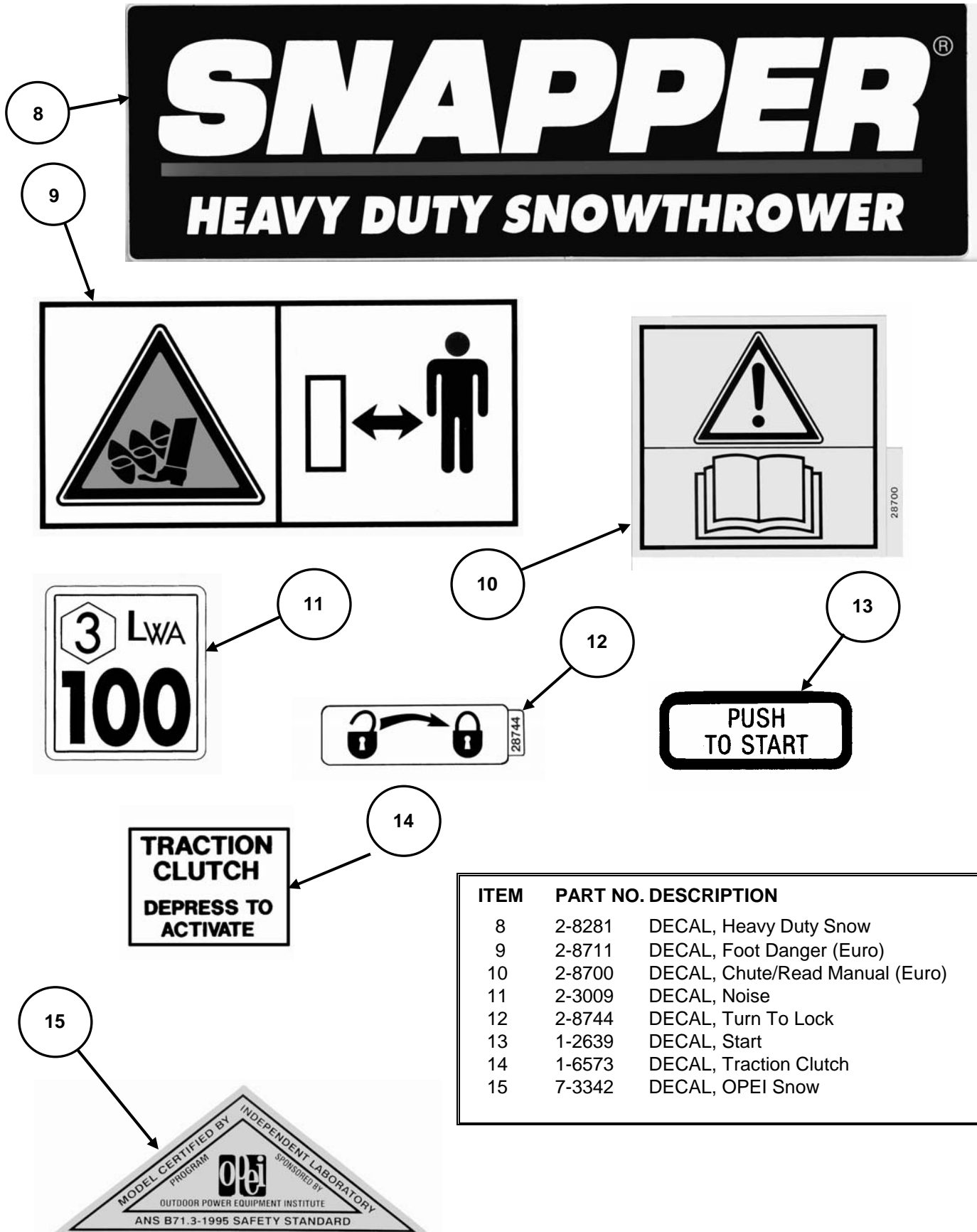

ITEM	PART NO.	DESCRIPTION
8	2-8281	DECAL, Heavy Duty Snow
9	2-8711	DECAL, Foot Danger (Euro)
10	2-8700	DECAL, Chute/Read Manual (Euro)
11	2-3009	DECAL, Noise
12	2-8744	DECAL, Turn To Lock
13	1-2639	DECAL, Start
14	1-6573	DECAL, Traction Clutch
15	7-3342	DECAL, OPEI Snow

DECALS
(Continued)

16

17



18



19



ITEM	PART NO.	DESCRIPTION
16	2-8279	DECAL, Control- 10/30
17	7-3483	DECAL, Control- 11/30
18	7-3482	DECAL, Control- E11/30
--	2-8214	DECAL, Control- 8/24 (not shown)
--	2-8695	DECAL, Ctrl.- E10/30 & N10/30(not shown)
--	4-5177	DECAL, Control- 9/26 (not shown)
--	4-5183	DECAL, Control- E9/26 (not shown)
--	2-8696	DECAL, Control- E8/26 (not shown)
--	4-5183	DECAL, Control- E9/26 (not shown)
19	7-3844	DECAL, Fuel Safety

ACCESSORIES

HARDWARE BAG KIT #6-1368 (for Model 8245)

PART NO.	DESCRIPTION
9-1070	NUT, 5/16-18 Hex Flange Lock, Grade 5 (4)
1-6314	WASHER, 5/16 x 1-1/4" Flat (2)
1-3849	SPACER
3-2910	LEVER, Clutch
2-8223	CABLE, Auger/Cable (2)
9-1067	NUT, 5/16-18 Hex Center Lock, Grade B
9-1071	NUT, 3/8-16 Hex, Grade B
1-6304	NUT, 3/8-16 x 1-3/4" Connector
1-1938	RETAINER, Chute
9-1075	SCREW, #10-24 x 5/8" Hex Washer Self-Tap (2)
1-3865	BOLT, 5/16-18 x 5/8" Shear (2)
9-1298	NUT, 5/16-18 Hex Nyloc (2)
9-0041	PIN, 1/8 x 1" Cotter
9-1082	PIN, 3/32 x 3/4" Cotter
9-1550	BOLT, 5/16-18 x 1-7/8" Shear (2)
9-1149	WASHER, 3/8 Flat

HARDWARE BAG KIT #6-1366 (for Model 8265)

PART NO.	DESCRIPTION
9-1070	NUT, 5/16-18 Hex Flange Lock, Grade 5 (8)
1-6314	WASHER, 5/16 x 1-1/4" Flat (2)
1-3849	SPACER
3-2910	LEVER, Clutch
9-1149	WASHER, 3/8 Flat
9-1067	NUT, 5/16-18 Hex Center Lock, Grade B
9-1071	NUT, 3/8-16 Hex, Grade B
1-6304	NUT, 3/8-16 x 1-3/4" Connector
1-1938	RETAINER, Chute
9-1075	SCREW, #10-24 x 5/8" Hex Washer Self-Tap (2)
9-1298	NUT, 5/16-18 Hex Nyloc (2)
9-0001	BOLT, 5/16-18 x 3/4" Short Neck Carriage
9-0187	WASHER, 5/16 Split Lock
9-0196	NUT, 5/16-18 Hex
9-0041	PIN, 1/8 x 1" Cotter
9-1082	PIN, 3/32 x 3/4" Cotter (2)
9-1550	BOLT, 5/16-18 x 1-7/8" Shear (2)

HARDWARE BAG KIT #6-1365

(for Models: E8265, 9265, E9265, 10305, 10305E, E10305, E10305E, 11305 and E11305)

PART NO.	DESCRIPTION	PART NO.	DESCRIPTION
9-1070	NUT, 5/16-18 Hex Flange Lock, Grade 5 (4)	1-3865	BOLT, 5/16-18 x 5/8" Shear (2)
1-6314	WASHER, 5/16 x 1-1/4" Flat (2)	9-1298	NUT, 5/16-18 Hex Nyloc (2)
1-3849	SPACER	2-8223	CABLE, Auger/Clutch
3-2910	LEVER, Clutch	9-0001	BOLT, 5/16-18 x 3/4" Short Neck Carriage (2)
9-0037	PIN, 3/32 x 3/4" Cotter (2)	9-0187	WASHER, 5/16 Split Lock (2)
9-1067	NUT, 5/16-18 Hex Center Lock, Grade B	9-0196	NUT, 5/16-18 Hex (2)
9-1071	NUT, 3/8-16 Hex, Grade B	9-0041	PIN, 1/8 x 1" Cotter
1-6304	NUT, 3/8-16 x 1-3/4" Connector	9-1082	PIN, 3/32 x 3/4" Cotter
1-1938	RETAINER, Chute	9-1550	BOLT, 5/16-18 x 1-7/8" Shear (2)
9-1075	SCREW, #10-24 x 5/8" Hex Washer Self-Tap (2)	1-2080	TIE, Cable 7" (2)

DRIFT CUTTER KIT #6-0472

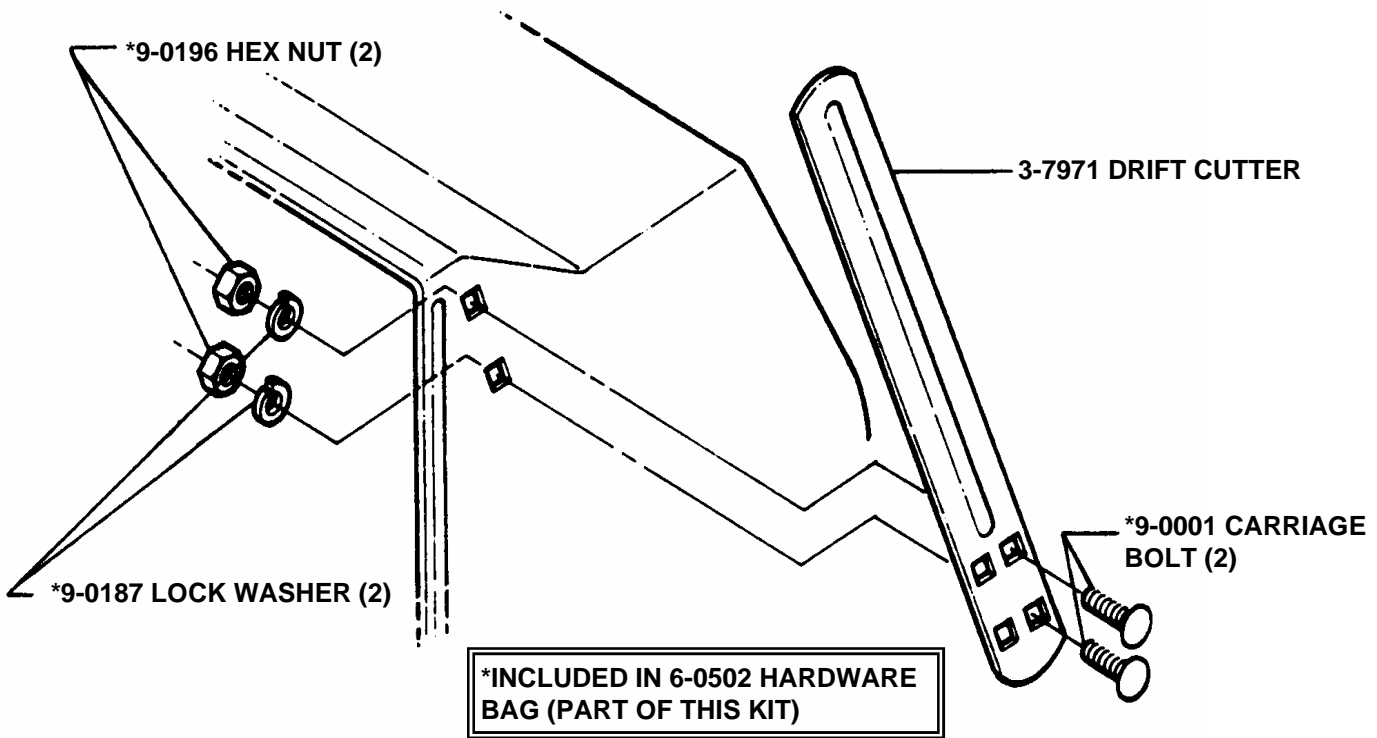

TIRE CHAIN KITS FOR SNOW HOG TIRES

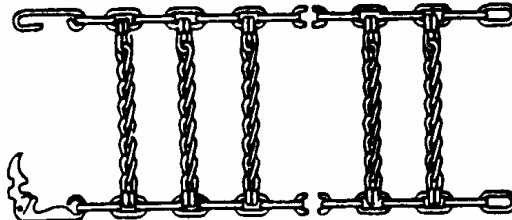

<p>MODELS 8245, 8265 9265 & E9265</p>	<p>TIRE SIZE 16-4.80 x 8</p>	<p>KIT NO. 6-0900*</p>
<p>MODELS 10305, 10305E E10305, E10305E 11305 & E11305</p>	<p>TIRE SIZE 16-6.50 x 8</p>	<p>KIT NO. 6-0927*</p>

***Each Kit Includes
Two (2) Chains**

ACCESSORIES (Continued)

ELECTRIC START KITS

**6-0759, KIT, 120 Volt Electric Start for Tecumseh HMSK 8 & 10 HP Engines
(Tecumseh Kit No. 179-84C)**

For use on USA Models 8245, 9265 and 10305

**6-3109, KIT, 230 Volt Electric Start for Tecumseh HMSK 8, 9 & 10 HP Engines
Includes 7-2610 Electric Starter Kit (Tecumseh No. 179-160) and
7-2611, 8' Extension Cord**

For use on Euro Models: E9265 & E10305

LIGHT KIT

6-1191, KIT, Light (for engines built with 18 watt internal alternator)

For use on Models 8265, E8265, 9265, E9265, 10305, 10305E, E10305 and E10305E)

SINGLE HANDLE CONTROL KIT

6-0991, KIT, Single Handle Control Retro-Fit

Fits Large Frame Snow Throwers After Models 8242, 8262 & 10302

REMOTE DEFLECTOR CONTROL KIT

6-1014, KIT, Remote Deflector Control

ACCESSORY LUBRICATION
Part No. 2-9577 GREASE, Benalene 900

Parts Manual for

SNAPPER®

TWO STAGE LARGE FRAME SNOW THROWER SERIES 5

MODELS	
8245	10305
8265	11305
E8265	10305E
9265	E10305
E9265	E10305E
	E11305

IT IS THE POLICY OF SNAPPER TO IMPROVE ITS PRODUCTS WHENEVER IT IS POSSIBLE AND PRACTICAL TO DO SO. WE RESERVE THE RIGHT TO MAKE CHANGES OR ADD IMPROVEMENTS AT ANY TIME WITHOUT INCURRING ANY OBLIGATION TO MAKE SUCH CHANGES ON PRODUCTS MANUFACTURED PREVIOUSLY.

SNAPPER®McDonough, GA., 30253 U.S.A.

COPYRIGHT © 2000
SNAPPER INC.
ALL RIGHTS RESERVED

MANUAL No. 06037

(Rev. 5, 7/03/00)

Printed in U.S.A.