

Technics

Compact Disc Player

SL-PG440

Operating Instructions



COMPACT
disc
DIGITAL AUDIO

Before operating this unit, please read these instructions completely.



GC GN

RQT1756-L
F1292L0

Thank you for purchasing this product.
For optimum performance and safety, please read
these instructions carefully.

Table of Contents

Suggestions for Safety	3
Installation	4
Preparations	4
Front Panel Controls and Functions	6
Concerning the Remote Control	8
Basic Operating Procedure	
(Sequential Play)	9
Direct Access Play	11

Random Play	12
Search/Skip Function	13
Program Play	14
Special Features	16
Recording from Compact Discs	20
Concerning Compact Discs	27
Technical Specifications	27
Troubleshooting Guide	Back cover
Maintenance	Back cover

CAUTION:

The AC voltage is different according to the area.

Be sure to set the proper voltage in your area before use.

(For details, please refer to the page 5.)

CAUTION!

THIS PRODUCT UTILIZES A LASER.
USE OF CONTROLS OR ADJUSTMENTS OR PERFORMANCE OF PROCEDURES OTHER THAN THOSE SPECIFIED HEREIN MAY RESULT IN HAZARDOUS RADIATION EXPOSURE.
DO NOT OPEN COVERS AND DO NOT REPAIR YOURSELF. REFER SERVICING TO QUALIFIED PERSONNEL.

**DANGER-Invisible
laser radiation when
open.
AVOID DIRECT EX-
POSURE TO BEAM.**

(inside of product)

Suggestions for Safety

■ Use a standard AC wall outlet

1. **Use from an AC power source of high voltage, such as that used for an air conditioner, is very dangerous.**

A fire might be caused by such a connection.

2. **A DC power source cannot be used.**

Be sure to check the power source carefully, especially on a ship or other place where DC is used.

■ Grasp the plug when disconnecting the power supply cord

1. **Wet hands are dangerous.**

A dangerous electric shock may result if the plug is touched by wet hands.

2. **Never place heavy items on top of the power supply cord, nor force it to bend sharply.**

■ Place the unit where it will be well ventilated

Place this unit at least 10 cm (4") away from wall surfaces, etc.

■ Avoid places such as the following:

In direct sunlight or in other places where the temperature is high.

In places where there is excessive vibration or humidity.

Such conditions might damage the cabinet and/or other component parts and thereby shorten the unit's service life.

■ Be sure to place the unit on a flat, level surface

If the surface is inclined, a malfunction may result.

■ Never attempt to repair nor reconstruct this unit

A serious electric shock might occur if this unit is repaired, disassembled or reconstructed by unauthorized persons, or if the internal parts are accidentally touched.

■ Take particular care if children are present

Never permit children to put anything, especially metal, inside this unit. A serious electric shock or malfunction could occur if articles such as coins, needles, screwdrivers, etc. are inserted through the ventilation holes, etc. of this unit.

■ If water is spilled on the unit

Be extremely careful if water is spilled on the unit, because a fire or serious electric shock might occur. Immediately disconnect the power cord plug, and consult with your dealer.

■ Avoid spray-type insecticides

Insecticides might cause cracks or "cloudiness" in the cabinet and plastic parts of this unit. The gas used in such sprays might, moreover, be ignited suddenly.

■ Never use alcohol or paint thinner

These and similar chemicals should never be used, because they might cause flaking or cloudiness of the cabinet finish.

■ Disconnect the power supply cord if the unit will not be used for a long time

If the unit is left for a long time with the power ON, this not only will shorten its useful operation life, but also may cause other trouble.

■ If trouble occurs

If, during operation, the sound is interrupted or indicators no longer illuminate, or if an abnormal odour or smoke is detected, immediately disconnect the power cord plug, and contact with your dealer or an Authorized Service Center.

Installation

Notes of placement

- **This unit is a precision instrument. Be sure to place it on a flat surface.**
 - **Avoid places such as the following:**
 - Near any equipment or device that generates strong magnetism.
 - On any heat-generating equipment or device, or in any place where the temperature is high (35°C or higher).
 - Extremely cold place (5°C or below).
 - Near a tuner or TV. (It may cause noise in the broadcast, or disturbance of the TV picture.)
 - **When carrying or storing the unit, handle it with care so it is not subjected to any strong bumps.**
- Always remove the disc before storing the unit for any period of time.
- **To avoid problems due to vibration.**
 - Do not place a book or similar object under this unit.
 - Do not route the connection cables (of this or other units) across the operation panel, across the top, or under the unit.

About moisture

Moisture may form on the lens in the following cases...

- Immediately after a heater has been turned on.
- In a steamy or very humid room.
- When the unit is suddenly moved from a cold environment to a warm one.

If moisture forms inside this unit, it may not work properly. In this case, turn on the power and wait about one hour for the moisture to evaporate.

Preparations

Supplied accessories

Check the packing carton for these accessories.

Note:

The configuration of the AC power supply cord differs according to area.

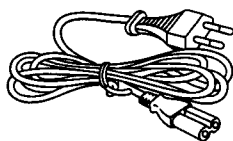

AC power supply cord 1

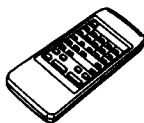

Remote control transmitter (RAK-SL304W) 1



Power plug adaptor 1
(For areas except Australia and New Zealand)

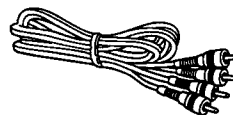

Stereo connection cable 1

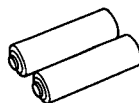

Batteries (UM-4, AAA, R03) 2

Connections

Before making connections, be sure that the power of this unit and all other system components is first turned off. See the operating instructions of the amplifier or the cassette deck for details.

Note:

The configuration of the AC outlet and AC power supply cord differs according to area.

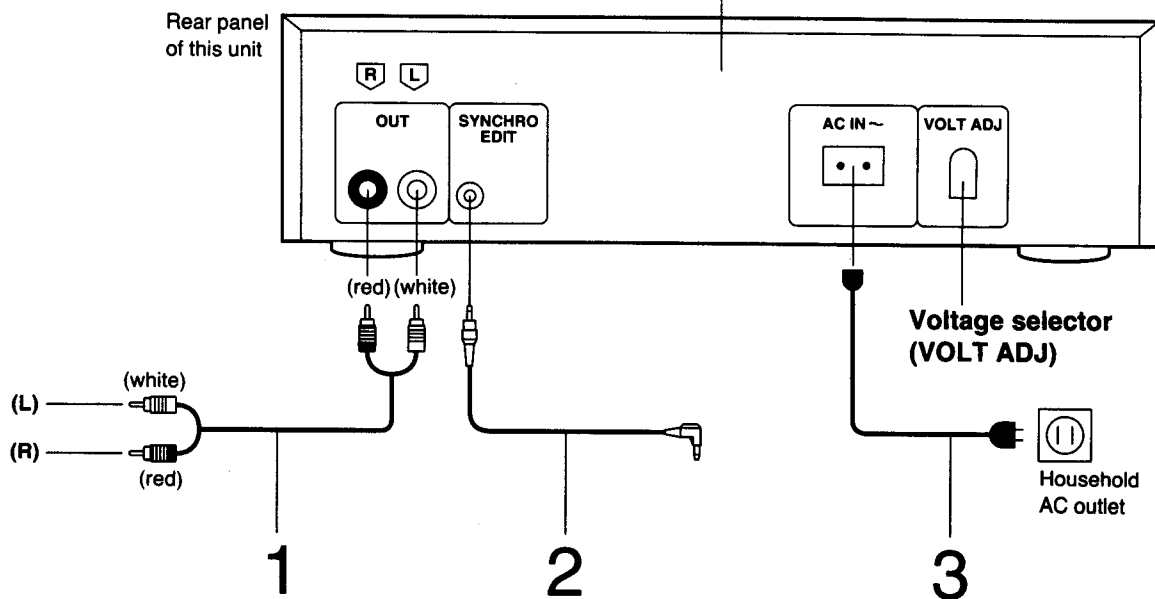

- 1** Connect the stereo connection cable (included) to the "CD" or "AUX" terminals of the amplifier.
- 2** Connect the synchro edit cable (included with the cassette deck) to the "SYNCHRO EDIT" terminal of the Technics cassette deck.

- 3** Connect the AC power supply cord (included) to the "AC OUTLET" of the amplifier or the household AC outlet.

For areas except Australia and New Zealand

Set the voltage selector (VOLT ADJ) to the voltage setting for the area in which the unit will be used.

- Use a minus (-) screwdriver.
- Note that this unit will be seriously damaged if this setting is not made correctly.
- If the power supply in your area is 117 V or 120 V, set to the "127 V" position.

For areas except Australia and New Zealand

If the power plug will not fit your socket, use the power plug adaptor (included).

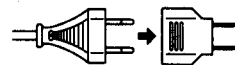

Insertion of Connector

Even when the connector is perfectly inserted, depending on the type of inlet used, the front part of the connector may jut out as shown in the drawing. However there is no problem using the unit.

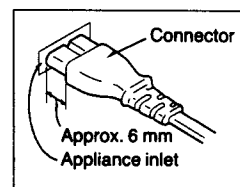

Front Panel Controls and Functions

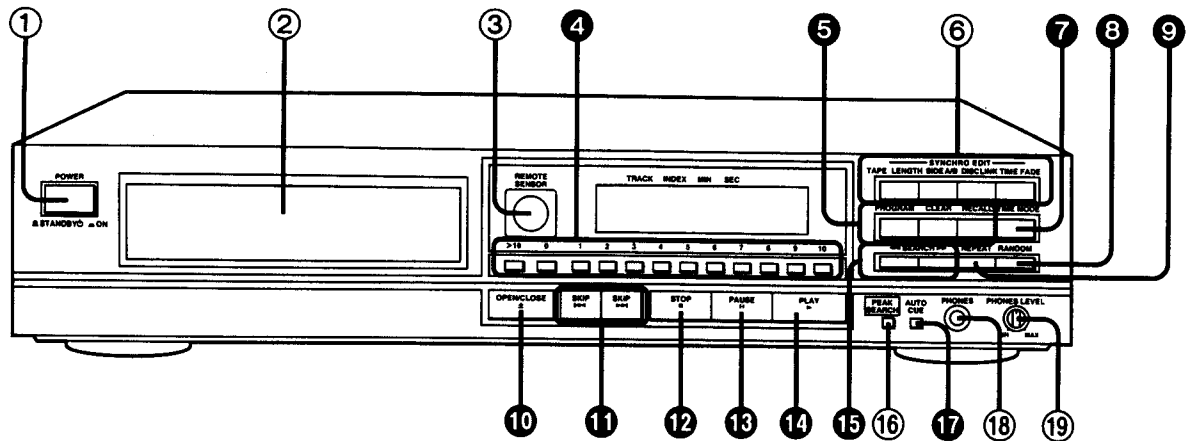

Control section

Numbers with black background (for example ④) indicate functions available on the remote control.

- ① **Power "STANDBY /ON" switch (POWER, STANDBY ON)**
This switch switches ON and OFF the secondary circuit power only. The unit is in the "standby" condition when this switch is set to the STANDBY position. Regardless of the switch setting, the primary circuit is always "live" as long as the power cord is connected to an electrical outlet.
- ② **Disc tray**
- ③ **Remote control signal sensor (REMOTE SENSOR)**
- ④ **Numeric buttons (1-10, 0, >10)**
- ⑤ **Buttons for program function**
 - Program button (PROGRAM)
 - Clear button (CLEAR)
 - Recall button (RECALL)
- ⑥ **Buttons for CD-Edit function**
 - Tape length button (TAPE LENGTH)
 - Tape side select button (SIDE A/B)
 - Disc link button (DISC LINK)
 - Time fade button (TIME FADE)
- ⑦ **Time mode select button (TIME MODE)**
- ⑧ **Random play button (RANDOM)**
- ⑨ **Repeat button (REPEAT)**
- ⑩ **Disc tray open/close button (OPEN/CLOSE)**
- ⑪ **Skip buttons (SKIP, SKIP)**
- ⑫ **Stop button (STOP)**
- ⑬ **Pause button (PAUSE)**
- ⑭ **Play button (PLAY)**
- ⑮ **Search buttons (SEARCH**
- ⑯ **Peak search button (PEAK SEARCH)**
- ⑰ **Auto cue button (AUTO CUE)**
- ⑱ **Headphones jack (PHONES)**
- ⑲ **Headphones volume control (PHONES LEVEL)**

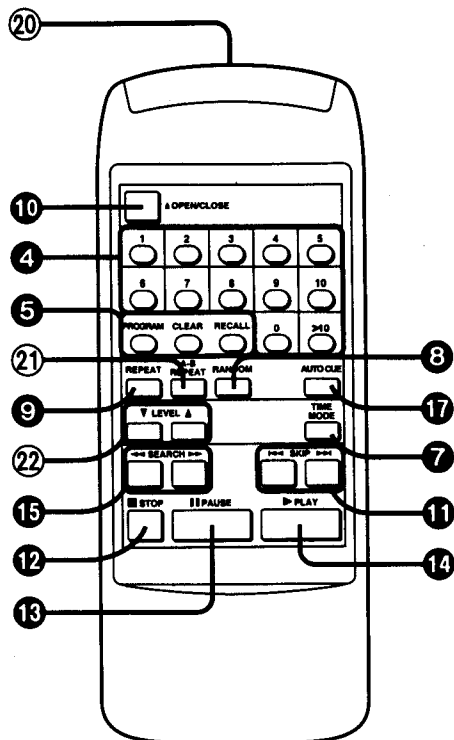

Remote control section

The functions indicated by numbers with black background (for example ④) are described under "Control section" on page 6.

- ⑳ Remote control transmission window
- ㉑ A-B repeat button (A-B REPEAT)
- ㉒ Level control buttons (▼ LEVEL ▲)

Concerning the Remote Control

Battery installation

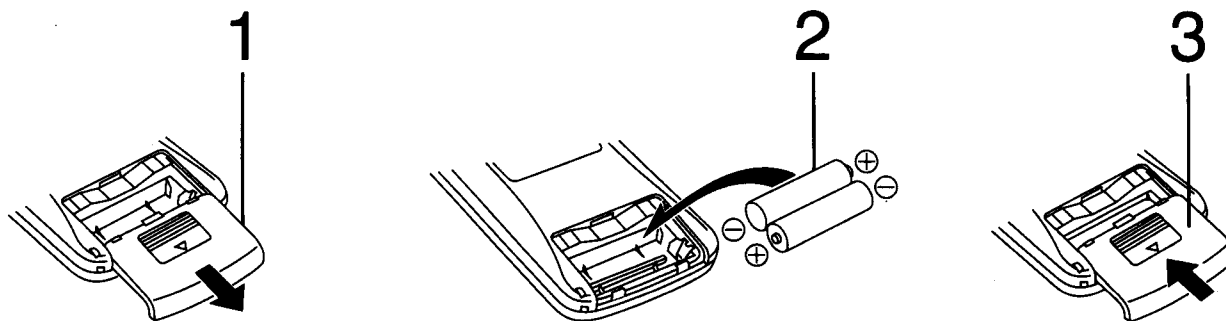

1 Open the cover.

Press gently and slide the cover out.

2 Insert the batteries included with this unit.

•When you replace these batteries, use two UM-4 "AAA", IEC R03 (1.5 V) or equivalent batteries.

•Be sure to insert batteries so that their positive (+) and negative (-) polarities match the indications in the compartment. Batteries installed incorrectly may leak and cause damage.

Refer to "Use of batteries" below for additional information.

3 Close the cover.

Use of batteries

- Do not mix old and new batteries or batteries of different types (carbon and alkaline, etc.).
- The average battery life is about one year. Although the battery life varies depending on how often the device is used, you should generally replace the batteries about once a year.
- Replace the batteries if commands from the remote control transmitter do not operate the unit even when the transmitter is held close to the front panel.
- Never subject batteries to excessive heat or flame; do not attempt to disassemble them; and be sure they are not short-circuited.
- If you will not be using the remote control for a long period of time, remove the batteries and store in a cool, dark place.

- If a battery leaks, remove all batteries and dispose of them properly. Thoroughly clean the battery compartment before inserting new batteries.
- If the leaking electrolyte comes in contact with skin or clothes, flush with water immediately.
- Keep batteries out of reach of children.
- Do not use rechargeable-type (nickel-cadmium) batteries.
- Do not attempt to recharge alkaline or carbon batteries.
- Always remove old, weak, or worn-out batteries and dispose of them properly.
- Do not dispose of used batteries in household rubbish.

Operation notes

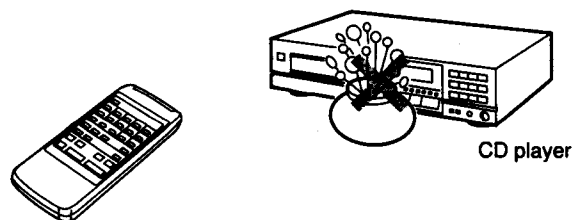

Aim the remote control's transmission window toward the CD player's sensor. Avoid any obstacles.

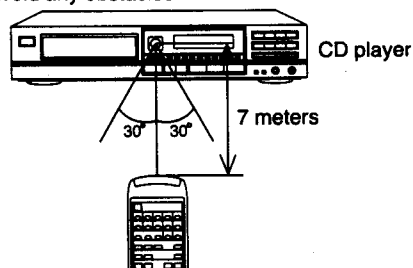

Use the remote control with a 60-degree angle of the CD player. Maximum distance is within 7 meters directly facing toward the CD player.

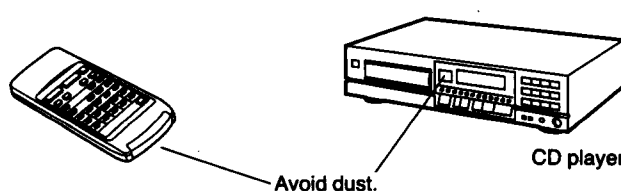

- Be sure the transmission window and the CD player's sensor are free from dust. Excessive dust might prevent reception.
- If direct sunlight or another strong light source strikes the remote control signal sensor part of the CD player, it may impair the remote control's operation. If there is a problem, place the CD player away from the light source.
- If this unit is installed in a rack with glass doors, the glass doors' thickness or color might make it necessary to use the remote-control transmitter a shorter distance from the unit.

Basic Operating Procedure (Sequential Play)

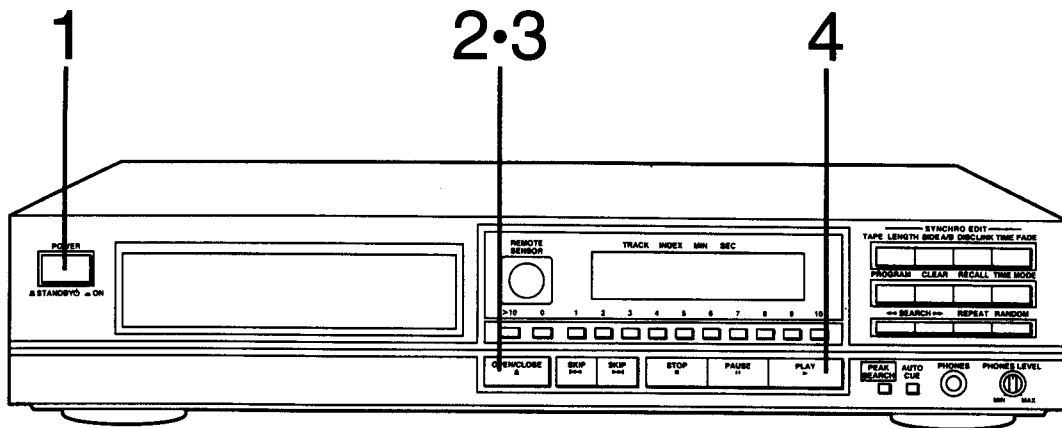

1 Press POWER to switch on the power.
If there is a disc in the disc tray, play will start from the first track.

2 Press \blacktriangle OPEN/CLOSE to open the disc tray and insert a disc.
(Also available from the remote control)

Label must face upward.

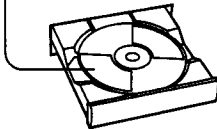

Before attempting to use the remote control transmitter to open the disc tray, make sure that there are no obstructions in front of the unit.

3 Press \blacktriangle OPEN/CLOSE again to close the disc tray.
(Also available from the remote control)

Total number of tracks Total playing time

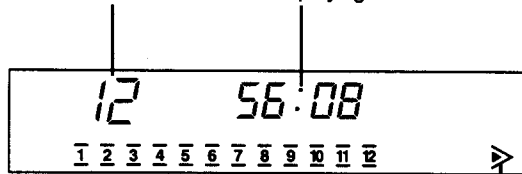

Lights when the total number of tracks exceeds 17

- The total playing time displayed includes the silent sections between tracks. For this reason, it may be a few seconds longer than the playing time indicated on the disc.
- You can skip this step and press \blacktriangleright PLAY. The disc tray will be automatically closed and then play will start from the first track.

4 Press \blacktriangleright PLAY.
(Also available from the remote control)

Index number

(For discs without index number, "I" will be continuously displayed.)

Track number in play Elapsed time Play indicator

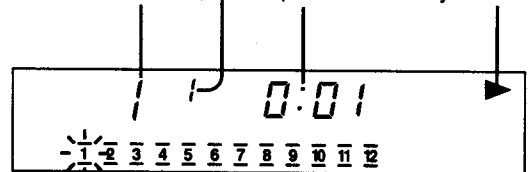

The unit stops automatically when the last track finishes playing.

Basic Operating Procedure (continued)

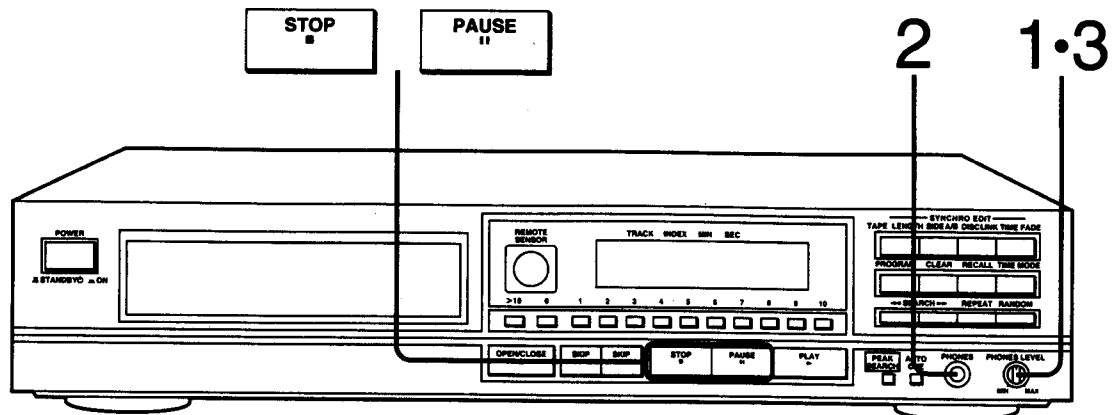

To stop disc play

(Also available from the remote control)

Press ■ STOP.



To temporarily stop disc play

(Also available from the remote control)

Press ▢ PAUSE.

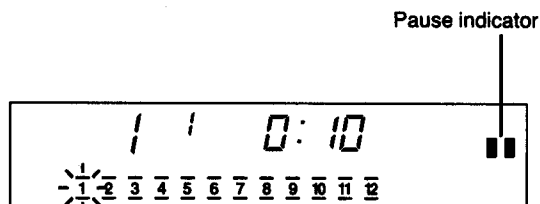

Press ► PLAY to resume play.

How to use headphones

- 1 Reduce the headphones volume level.
- 2 Connect the headphones to the headphones jack.
Plug type: Stereo large plug
- 3 Adjust the volume.
Avoid listening for prolonged periods of time to prevent hearing damage.

Direct Access Play

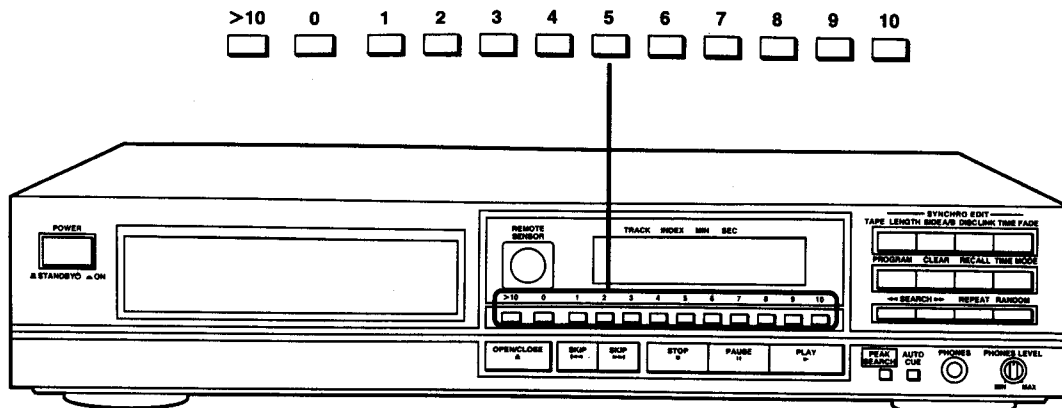

To start sequential play from a desired track. Play will progress to the last track of the disc.

(Also available from the remote control)

Before beginning, follow steps 1–3 of “Basic Operating Procedure” on page 9.

Press the numeric button to select the track.

•To select a track between 1 and 10:

Press the corresponding number on the keypad.

•To select a two-digit track number over 10:

Press >10 then one of the buttons from 1 to 9 to select the “tens” digit. Then press one of the buttons from 0 to 9 to select the “unit” digit.

For example:

•To select track number 25: >10 → 2 → 5

•To select track number 30: >10 → 3 → 0

Play begins with the track selected and continues to the end of the disc. The unit will stop automatically when the last track finishes playing.

Random Play

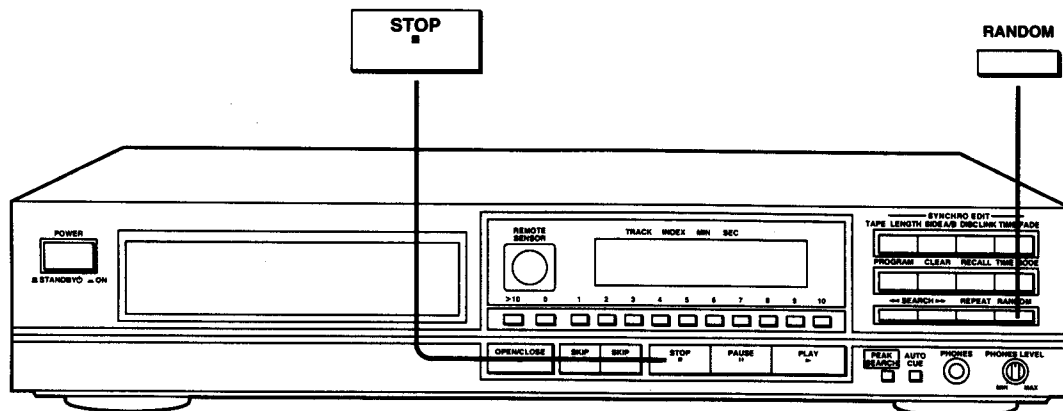

The unit will automatically select the sequence of selections to be played from the disc in a random manner.

(Also available from the remote control)

Before beginning, follow steps 1-3 of "Basic Operating Procedure" on page 9.

Press **RANDOM** in play or stop mode.

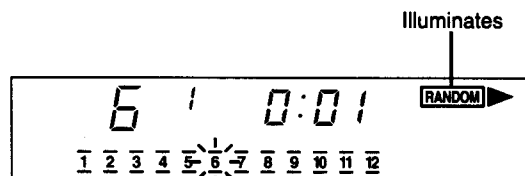

The unit stops automatically when all tracks have played once. (Random play mode will be cancelled.)

● **In the program play mode** (See page 14.):

The unit plays only the programmed tracks in random manner.

To cancel random play

Press ■ **STOP**.

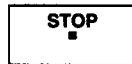

When you press **RANDOM** in the play mode, play continues from subsequent tracks in the normal order to the end of the disc.

Search/Skip Function

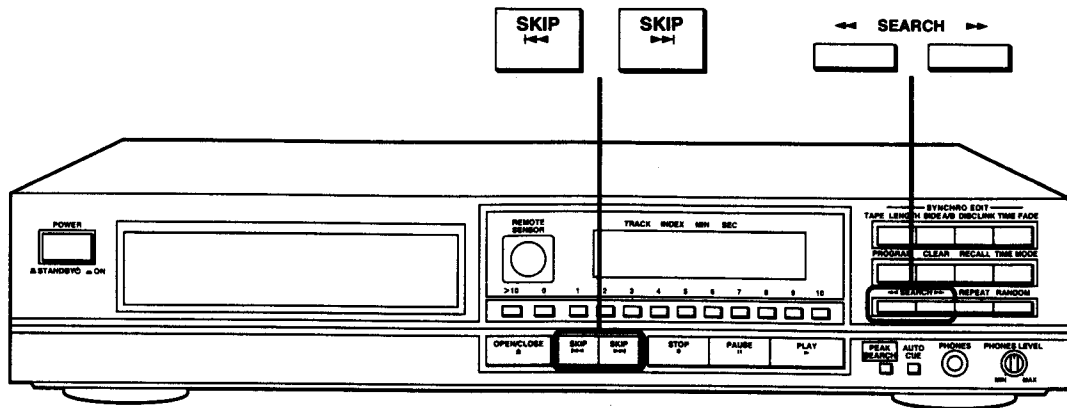

Search Function

In play or pause mode, you can search rapidly forward or backward on the disc for specific sections.

(Also available from the remote control)

Press ◀◀SEARCH▶▶.



- You can search slowly at first and then rapidly if the button is held down for more than about three seconds.
- In the pause mode, no sound is heard. It remains at the point where you release the button.
- **In the random and program play mode:** You can search forward and backward within the track in play.
- **During A-B repeat play (See page 17.):** You can search out of the range between A and B.

Skip Function

(Also available from the remote control)

To skip forward, press ▶▶ SKIP.



You can skip as many tracks as the number of times you press the button.

To skip backward, press ◀◀ SKIP.



You can skip to the beginning of the track being played. If you press this button again quickly, you can skip to the beginning of the previous track. Remember that in a backward skip, the track in play is included in the count.

• In the pause mode:

The unit will move to the beginning of the selected track and switch back to the pause mode.

• In the stop mode:

The unit displays only the selected track number. Press ▶ PLAY to start.

• In the program play mode:

You can skip forward and backward in the programmed sequence.

• In the random play mode:

▶▶ : You can skip to the beginning of a track in random manner.

◀◀ : You can skip to the beginning of the track in play.

Program Play

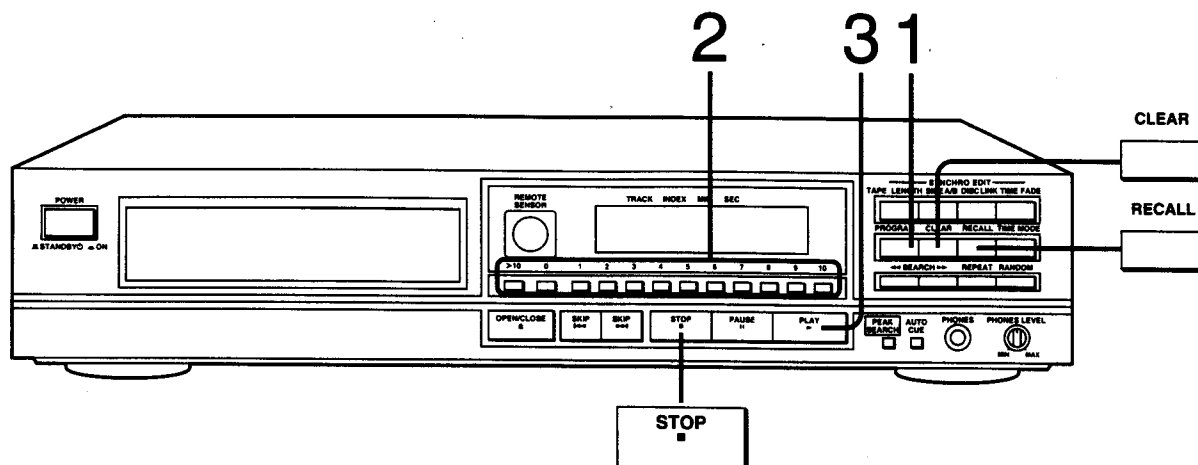

You can program up to 20 tracks in any order you desire.

(Also available from the remote control)

Before beginning, follow steps 1–3 of “Basic Operating Procedure” on page 9.

1 In the stop mode, press PROGRAM.

If you press this button in the play mode, the track in play will be programmed.

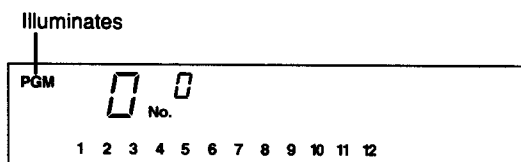

2 Press a numeric button to specify the track number.

•To select a track between 1 and 10:

Press the corresponding number on the keypad.

•To select a two-digit track number over 10:

Press >10 then one of the buttons from 1 to 9 to select the “tens” digit. Then press one of the buttons from 0 to 9 to select the “unit” digit.

For example:

To select track number 25: >10 → 2 → 5

To select track number 30: >10 → 3 → 0

For example, if you press , , :

The last track in programmed order
Number of
programmed tracks

Total playing time of
programmed tracks

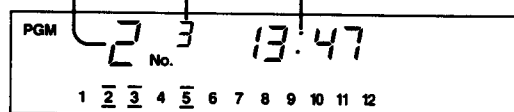

If you press a wrong number by mistake, press CLEAR.

•When the 21st program has been performed, the following display indicates that no more tracks can be added.

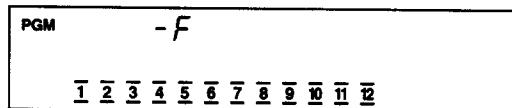

•If the total playing time exceeds 99 minutes 59 seconds or if the track number 21 or higher has been specified, the display reads as follows:

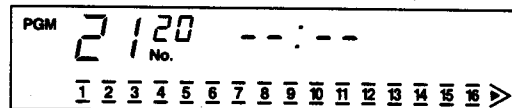

3 Press ► PLAY to start.

•The unit stops automatically when all the programmed tracks have finished playing.

•Even after play is completed, the program sequence will remain in the unit's memory. You can play the sequence again by pressing ► PLAY.

To switch to sequential mode during play

Press PROGRAM.

PROGRAM



This clears all programmed contents from memory.

To cancel the program play mode

Press ■ STOP.



Press once in the stop mode and twice during play.
This clears all programmed contents from memory.
Turning off the power will also cancel the program play mode.

To confirm the program

Press RECALL.

RECALL



Each time you press RECALL, the display shows programmed track number and its sequence, so that you can verify the entire program.

For example:

The diagram shows a program consisting of tracks 5, 3, 2.

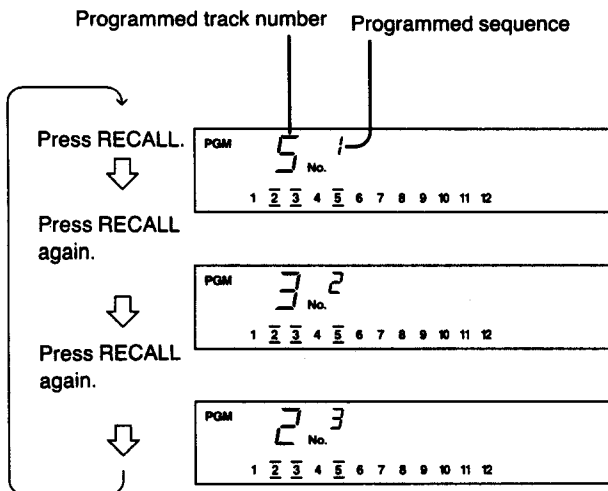

The normal display will resume in about 4 seconds.

To enter additional tracks

Press a numeric button to specify the track number.

(See page 14.)

To clear the entry

■ To clear the last track in the sequence, press CLEAR in the stop mode.

CLEAR



■ To cancel a track in the middle of the sequence, press RECALL repeatedly until the display shows the track number to be cancelled, then press CLEAR.

RECALL

CLEAR



■ To cancel all the programmed tracks, press PROGRAM twice in the stop mode and return to step 2 on the previous page.

PROGRAM



Special Features

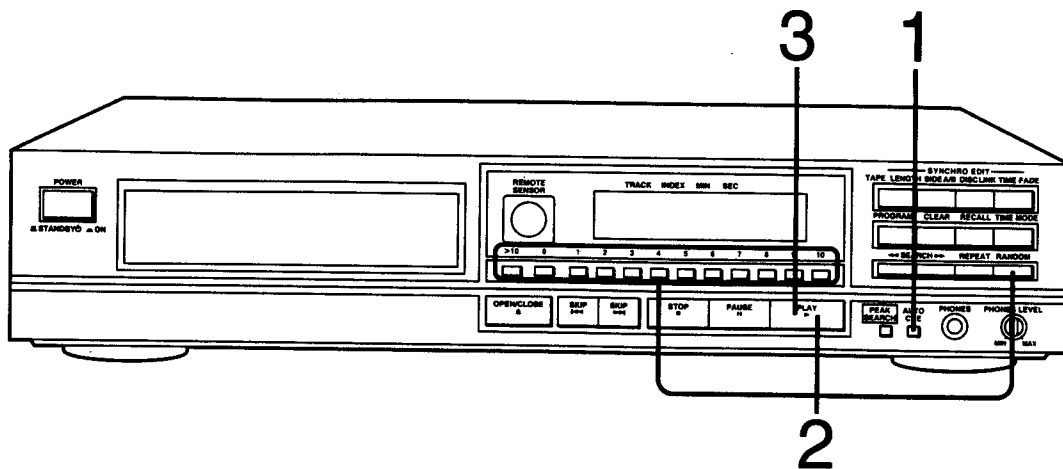

Auto cue

The auto cue function allows the unit to wait in a standby condition at the beginning of each track so as to start play right when you are ready.

When each track finishes playing, the unit skips to the beginning of the next track and switches to the play standby mode.

(Also available from the remote control)

1 Press AUTO CUE.

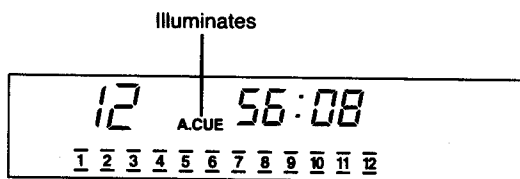

2 Select the desired play mode.

- To play desired track, press the numeric button.
- To play track 1, press ► PLAY.
(Also available during program play. See page 14.)
- To play the disc randomly, press RANDOM.

The unit switches to the play standby mode.

3 Press ► PLAY to start.

Press ► PLAY at the beginning of each track.

■ To cancel auto cue

Press AUTO CUE again.



Note:

The auto cue may fail to function at the proper point if the selected track begins with a very soft passage or if there is a lot of background noise.

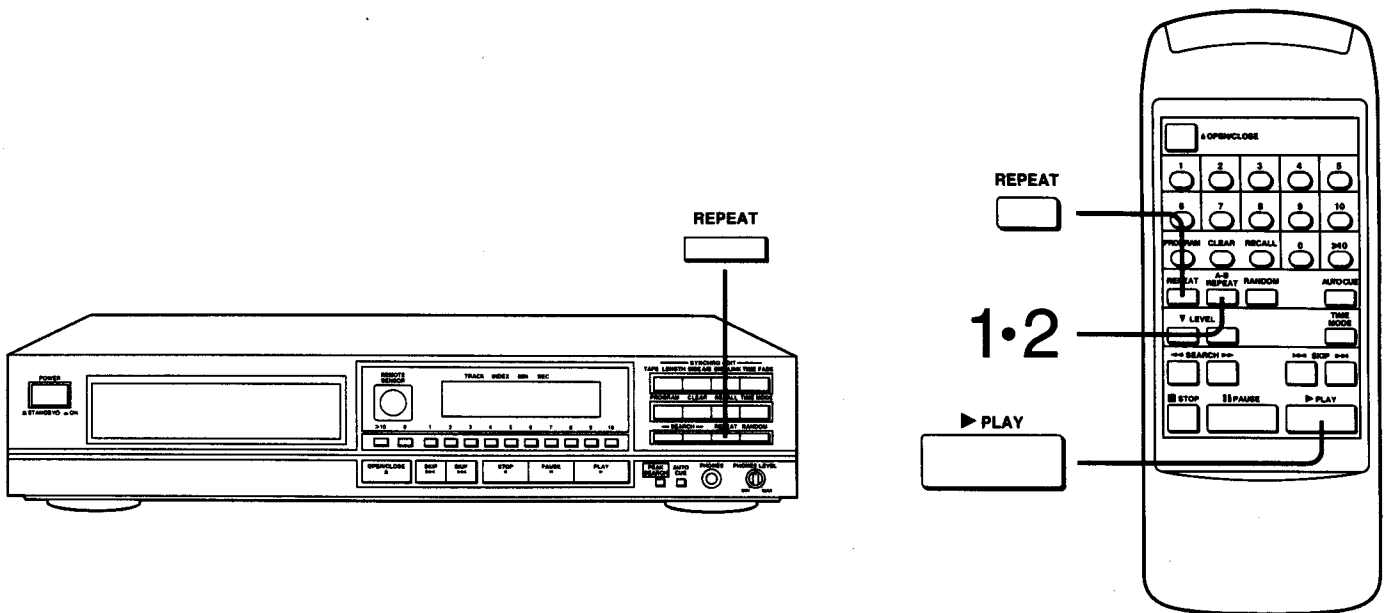

Repeat function

■ To repeat tracks

Press **REPEAT**.

(Also available from the remote control)

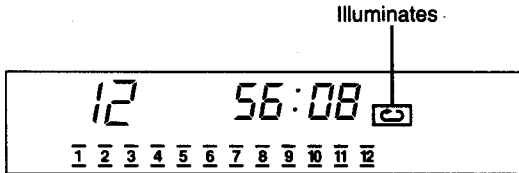

During program play, the unit plays only the programmed tracks repeatedly.

To cancel repeat function, press **REPEAT** again.

REPEAT



■ A-B repeat play

(Available only from the remote control)

You can specify the beginning point (A) and the ending point (B) of the section and repeat only that section.

This function works during sequential and direct access play.

- 1 During play, press **A-B REPEAT** at the point where you want the repetition to begin.

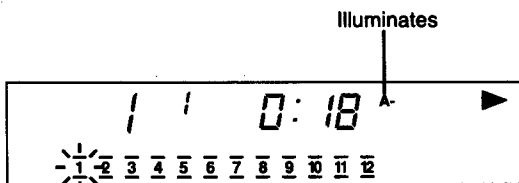

- 2 Press **A-B REPEAT** again at the point where you want the repetition to end.

The unit will play the section between A and B repeatedly.

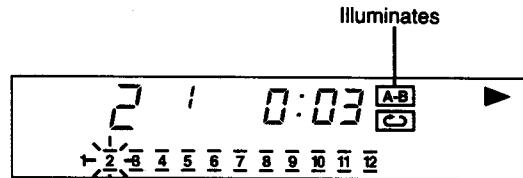

To cancel the A-B repeat, press **A-B REPEAT** again.

A-B REPEAT



Hint:

To return to the (A) point during A-B repeat play, press **▶ PLAY**. You can specify only the beginning point (A). Press **▶ PLAY** to skip to (A) point. (Cue memory function)

Note:

A-B repeat function and cue memory function do not work on the program play and random play modes.

Special Features (continued)

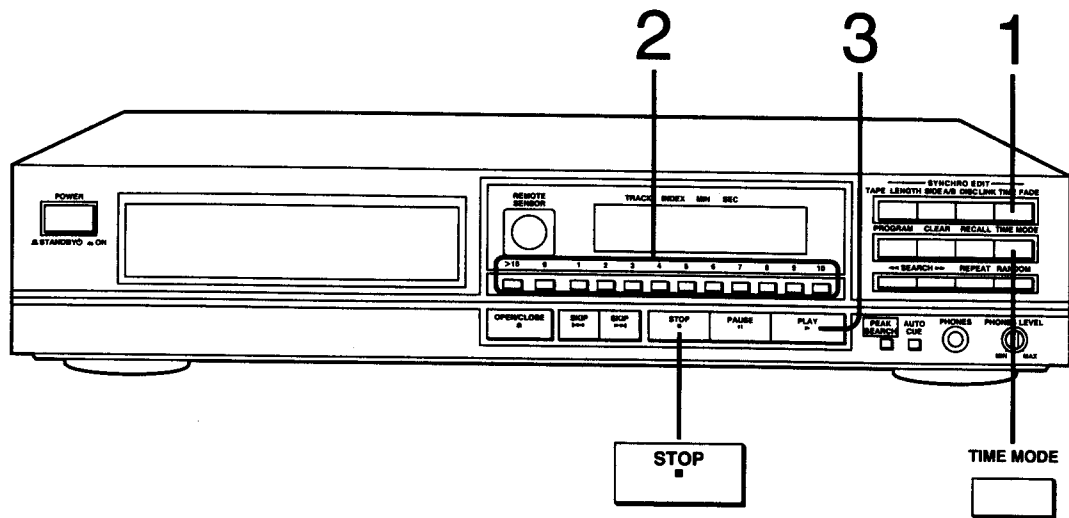

Time fade function

The time fade function allows the unit to finish the play with fade-out. You can specify the time (from 5 sec. to 99 min. 59 sec.) when the fade-out of 5 seconds is finished.

- 1 Press TIME FADE in the pause or stop mode.**
The "----" indication will be shown on the display panel.
- 2 Press the numeric buttons to enter the desired time.**

(Also available from the remote control)

For example:

If you want the fade-out to be finished 30 minutes later.

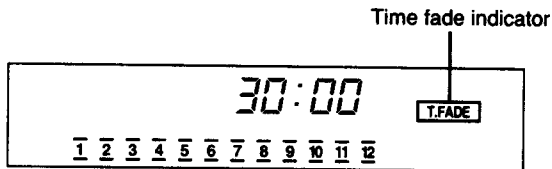
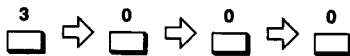

If you want to change the time while entering, press CLEAR to cancel it.

- 3 Press ► PLAY.**

(Also available from the remote control)

The fade-out begins 5 seconds before the specified time.

The time fade indicator flashes on and off.

After the fade-out is finished, the unit goes into the pause mode. The time fade indicator goes out.

■ To see the remaining time

Press TIME MODE three times in the play mode.

(See page 19.)

(Also available from the remote control)

TIME MODE

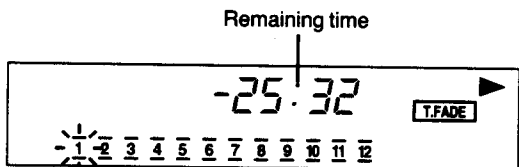

■ To cancel time fade function

Press ■ STOP.



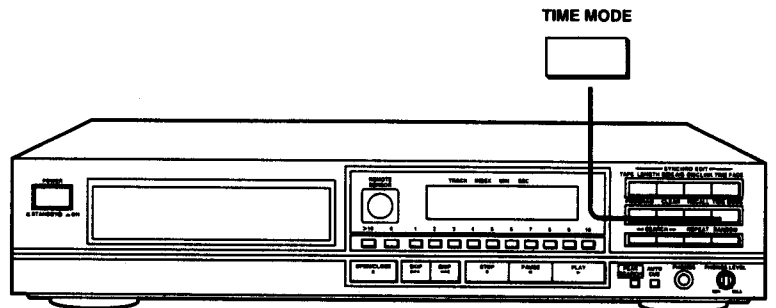
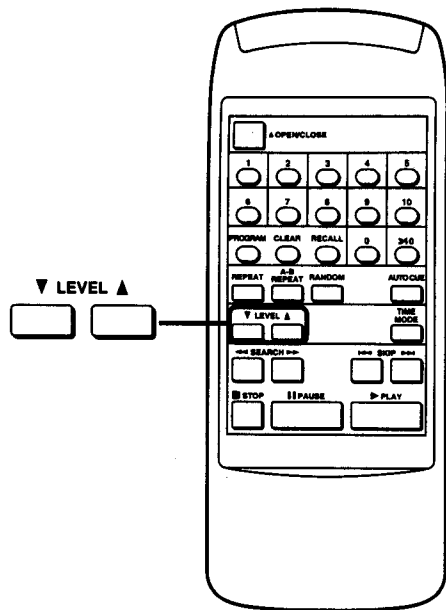

Output level control

(Available only from the remote control)

The output level can be temporarily decreased by this means, instead of adjusting the volume of the amplifier.

Press ▼ LEVEL to lower the output level.



You can reduce the output level from 0 dB (normal level) down to -12 dB by 2 dB steps.

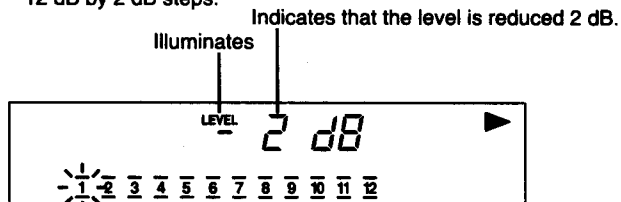

The display returns to the original state after about 2 seconds. When the power is switched off and then switched back on again, the level returns to 0 dB.

To raise the output level, press LEVEL ▲.



Note:
This unit is designed so that the output level cannot be adjusted in the edit mode to avoid changing the recording level.

Time mode selection

(Also available from the remote control)

Press TIME MODE in the play or pause mode.

Each time you press the button, the information will change as follows.

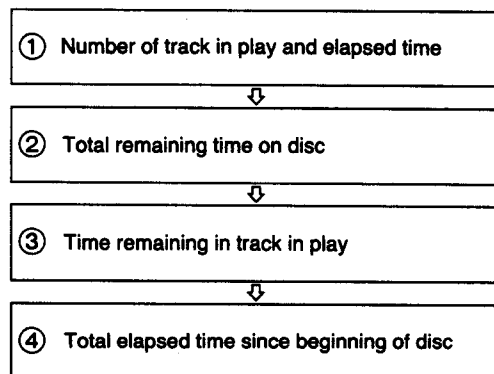

●When the track in play is number 21 or higher:

The "----:" indication will appear on display ③.

●In the random play mode:

The "----:" indication will appear on display ② and "----:" on display ④.

●In the fade out mode:

The remaining time till the fade-out will appear between the displays ③ and ④.

●In the edit mode:

The remaining time of each side of the tape will appear on display ②.

●In the program play mode:

The information displayed on displays ② and ④ is only within the programmed tracks.

Recording from Compact Discs

The edit function of this unit is used when recording from compact discs to tape. Tracks can be recorded on both sides (sides A and B) of the tape, considering the length of the tape used, so that there is no interruption of tracks at the end of one tape side.

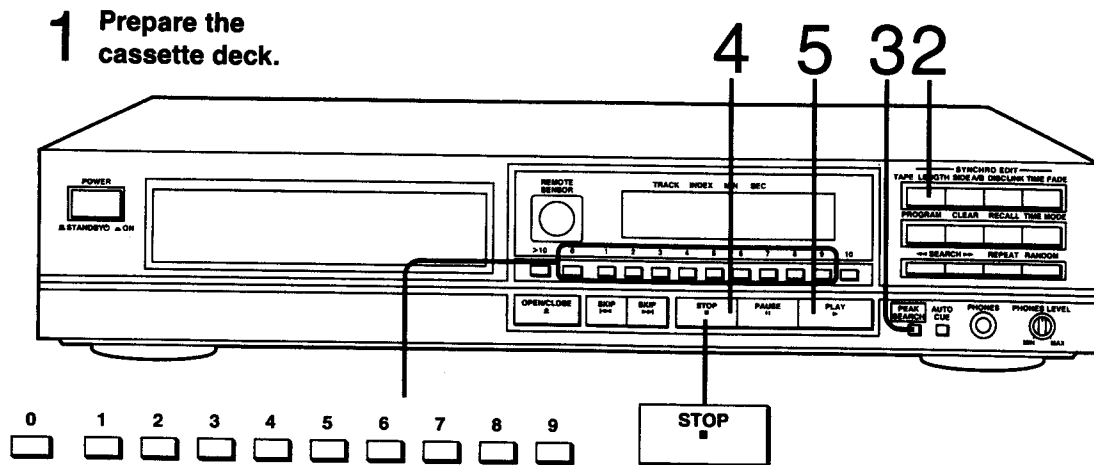

Sequential recording (Automatic editing)

If you use this unit in combination with the Technics cassette deck which has the SYNCHRO EDIT terminal, recording on the cassette deck will start automatically at the same time you start CD play (synchro recording function).

Also, if you set the cassette deck to the auto-reverse mode, both sides of the tape will automatically be recorded.

The maximum numbers of tracks allowable for editing is 20 and the biggest track number allowable for editing is 20. The edit function does not work for more than 20 tracks nor the track number over 20.

1 Prepare the cassette deck for recording.
(See next page.)

2 Press TAPE LENGTH to select the tape length.
Each time the button is pressed the tape length indicator changes as follows. Choose the length of the tape to be used.

(→ C-46 ⇄ C-60 ⇄ C-90 ⇄ C-∞ ⇄)

To enter desired recording time, see next page.

The unit will calculate how many tracks can be entered onto tape side A and B, and then program them automatically.

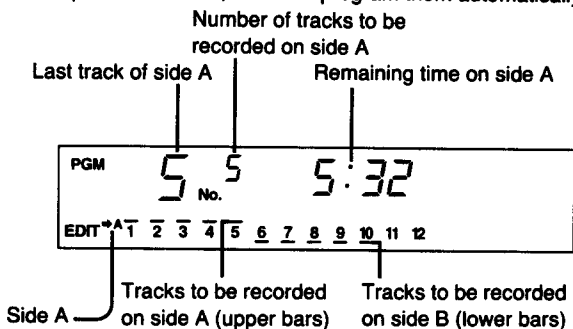

- In the edit mode, silent gaps of approximately 3 seconds will be automatically inserted between tracks automatically (auto space function).
- To enter additional tracks at the tape end of side B, see "To change the programmed contents" on page 23.

3 Press PEAK SEARCH to search for the peak point then adjust the recording level on the cassette deck.

It takes about 1.5 minutes to find the peak point for a 60-minute compact disc.

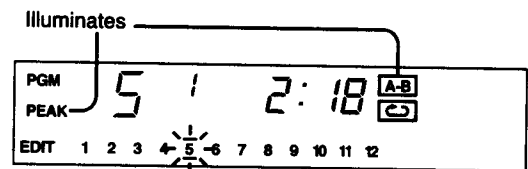

- When the peak point is found, the unit repeatedly produces the sound for about 6 seconds around the peak point.
- As there are many peak points on the disc, each time you make a new peak level search the unit might find a different point as the peak point.
(Refer to operating instructions for the cassette deck to find out how to adjust the recording level.)

4 Press ■ STOP.

5 Press ► PLAY to start.

Recording on the cassette deck will start at the same time.

- If the cassette deck is set to the auto-reverse mode, recording from tape side B will follow automatically.
- When recording from tape side B is finished, the CD player will automatically stop and the cassette deck will switch to recording standby mode.

To cancel the edit mode

Press ■ STOP after recording has finished.

STOP

How to prepare the cassette deck for recording

1. Insert the cassette tape into the cassette holder of the deck for the synchro-edit-recording. (Be sure the tape is rewound.)
2. Select the noise-reduction system and the reverse mode (↔).
3. Check to be sure that the forward-side indicator (▶) of the deck to be used is illuminated.
4. Set the cassette deck to the recording standby mode. (Refer to operating instructions for the cassette deck to be used.)

If the cassette deck has no SYNCHRO EDIT terminal

Press the play button of the cassette deck at the same time as pressing ▶ PLAY on the CD player to start recording.

- When the deck has reverse mode, set to one-way (→).
- When the recording for side A is finished, the CD player will go to the pause mode. The cassette deck will keep recording.
- To record on side B, first press the stop button on the cassette deck, then start recording again on side B while at the same time pressing ▶ PLAY on the CD player.

To enter desired recording time other than 46, 60 or 90 minutes

Press TAPE LENGTH to select "C----" then press the numeric buttons to enter the tape's total playing time in minutes.

TAPE LENGTH



>10 0 1 2 3 4 5 6 7 8 9 10

For example:

To enter C-52, press 5 then 2.

If you make a mistake, select "C----" again and enter the correct number.

Recording from Compact Discs (continued)

- 1 Prepare the cassette deck.
- 2 Enter the track numbers.
- 5 Adjust the recording level.
- 6 3 4

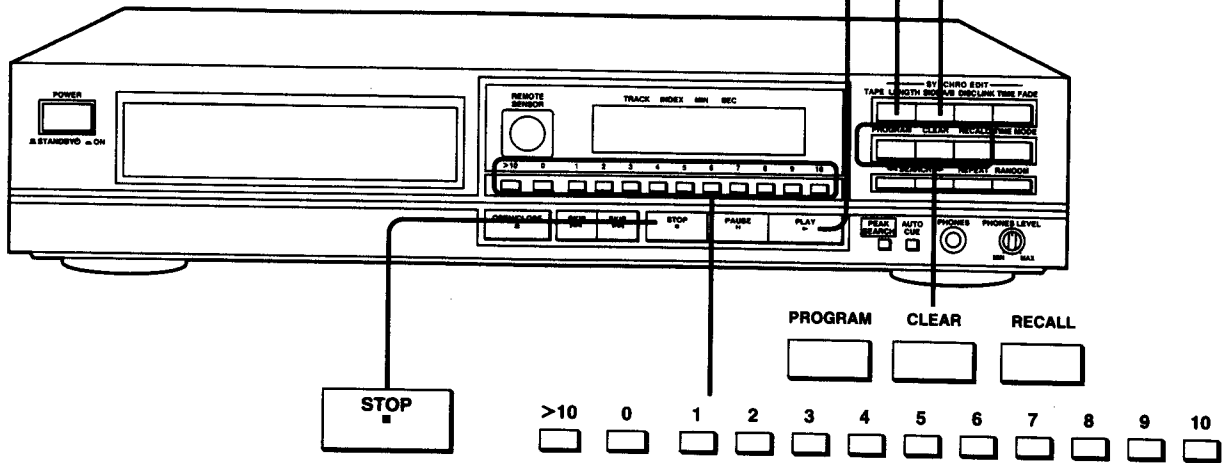

Program editing

You can make an original tape consisting of your favorite tracks, in any sequence desired. The maximum number of tracks allowable for editing is 20 and the biggest track number allowable for editing is 20. The edit function does not work for more than 20 tracks nor the track number over 20.

- 1 Prepare the cassette deck for recording. (See page 21.)
- 2 Enter the desired track numbers and the desired sequence. (See page 14.)

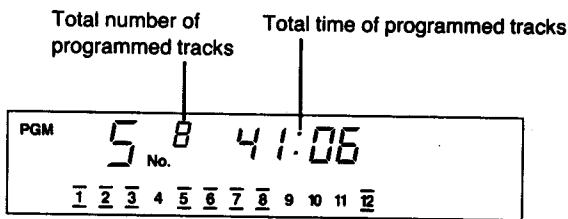

In the edit mode, silent gaps of approximately 3 seconds will be automatically inserted between tracks automatically (auto space function).

- 3 Press **TAPE LENGTH** to select the tape length. (See step 2 on page 20.)

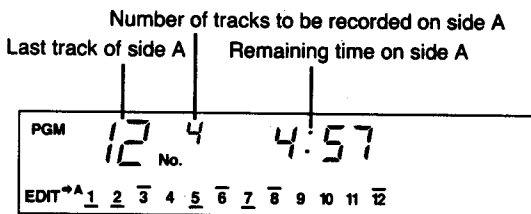

- 4 Press **SIDE A/B** to view the time remaining on side B.

A minus (-) sign on the remaining time display indicates that the total time of programmed tracks exceeds the tape length, and the programmed contents should be changed. (See page 23.)

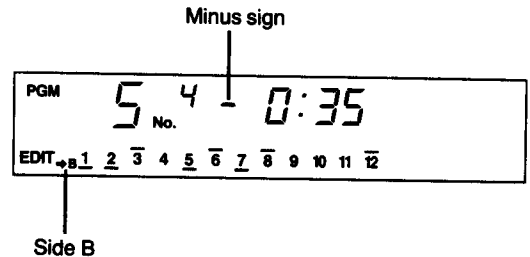

- 5 Adjust the recording level on the cassette deck. (Follow steps 3 and 4 on page 20.)

- 6 Press **▶ PLAY** to start. Recording on the cassette deck will start at the same time.

- If the cassette deck is set to auto-reverse, recording on tape side B will begin automatically.
- When recording on tape side B has finished, the CD player will automatically stop and the cassette deck will switch to recording standby mode.

To cancel the edit mode

Press ■ STOP after recording has finished.

STOP
■

If the cassette deck has no SYNCHRO EDIT terminal

Press the play button of the cassette deck at the same time as pressing ► PLAY on the CD player to start recording.

- When the deck has reverse mode, set to one-way (⇄).
- When the recording for side A is finished, the CD player will go to the pause mode. The cassette deck will keep recording.
- To record on side B, first press the stop button on the cassette deck, then start recording again on side B while at the same time pressing ► PLAY on the CD player.

To change the programmed contents

■ Press SIDE A/B to indicate the desired tape side.

SIDE A/B



■ To enter additional tracks at the end of side A or B, press the numeric button.

(See page 14.)

■ To clear the last track on the tape side A or B, press CLEAR.

CLEAR



■ To clear and re-enter the last track on side A or B, press CLEAR and press the numeric button for the new track.

CLEAR

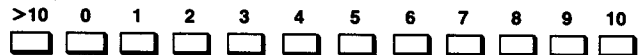

■ To clear a track in the middle of the sequence, press RECALL to display the track number to be cleared and then press CLEAR.

RECALL



CLEAR



Recording from Compact Discs (continued)

1 Prepare the cassette deck.

4 Adjust the recording level.

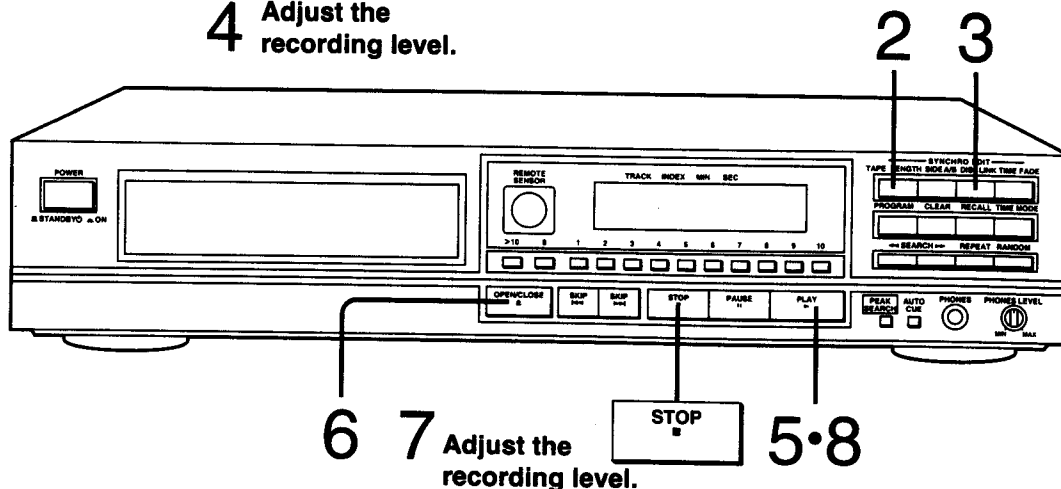

Link function

You can record desired tracks from multiple discs, keeping the total playing time for all discs in memory.

For example, to record a 60 minute disc on a 90 minute tape and to record another disc in the space remaining on the tape:

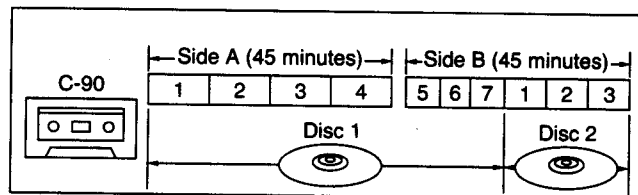

1 Prepare the cassette deck for recording.

2 Press TAPE LENGTH to select the tape length.
(See step 2 on page 20.)

3 Press DISC LINK.

Disc link indicator

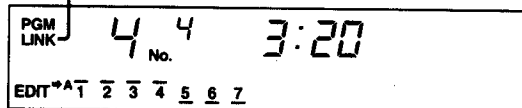

4 Adjust the recording level on the cassette deck.
(Follow the steps 3 and 4 on page 20.)

5 Press ► PLAY.

Recording on the cassette deck will start at the same time.

• If the cassette deck is set to the auto-reverse mode, recording on tape side B will be automatically made.

• When recording on tape side B has finished, the CD player will automatically stop and the cassette deck will switch to recording standby mode.

6 Replace the disc with another.

1. After recording is completed, press ▲ OPEN/CLOSE.

2. Replace the disc.

3. Press ▲ OPEN/CLOSE again.

The disc link function works and the display shows the number of tracks to be recorded on the remaining time.

Number of tracks to be recorded in the remaining space on side B

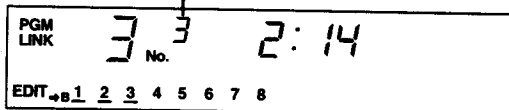

7 Adjust the recording level on the cassette deck.
(Follow the steps 3 and 4 on page 20.)

8 Press ► PLAY.

To record more discs if the remaining time of the tape allows, repeat the steps 6-8.

Note:

Use of the link function cannot be continued when the disc is changed over near the end of side A and the remaining time on that side is shorter than the play time of the track or tracks which are to be edited. At times like this, fast forward the tape to the beginning of side B and resume the recording.

■ **Example:**

Recording the desired tracks from 3 discs on 60 minute tape

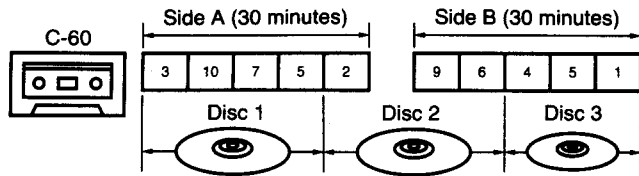

Recording for disc 1

- 1 Prepare the cassette deck for recording.
- 2 Press PROGRAM and then enter the desired track number in desired sequence.



- 3 Press TAPE LENGTH twice to select "C-60".
- 4 Press DISC LINK.
- 5 Adjust the recording level on the cassette deck.
- 6 Press ► PLAY to start recording.

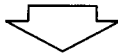

Recording for disc 2

- 1 After recording is completed, press ▲ OPEN/CLOSE.
- 2 Replace disc 1 with disc 2.
- 3 Press ▲ OPEN/CLOSE again.
The unit automatically programs tracks on the remaining space and the display shows the number of tracks to be recorded, in normal sequence.
- 4 Press CLEAR to cancel the tracks automatically programmed.
Press the button repeatedly until the display shows "0".
- 5 Enter the track number for side A.



- 6 Press SIDE A/B to switch the display.
- 7 Press CLEAR to cancel the tracks automatically programmed.
- 8 Enter the track number for side B.



- 9 Adjust the recording level on the cassette deck.
- 10 Press ► PLAY to start recording.



Recording for disc 3

- 1 After recording is completed, press ▲ OPEN/CLOSE.
- 2 Replace disc 2 with disc 3.
- 3 Press ▲ OPEN/CLOSE again.
- 4 Press CLEAR until the display shows "0".
- 5 Enter the track number.



- 6 Adjust the recording level on the cassette deck.
- 7 Press ► PLAY to start recording.

Notes:

- The "0" may appear on the track display after you replace the disc. This means that the first track on that disc is longer than the remaining space of the tape. In this case, press ■ STOP to cancel the edit mode.
- If the cassette deck has no synchro edit terminal, the tape will keep running even after disc play has been completed. Press the stop button on the cassette deck.
- Do not forget to stop the tape and rewind it to the position where recording was completed. If the deck is not equipped with an auto reverse mode, change the tape over to side B when the recording on side A is finished.

■ **To cancel the link function**

Press ■ STOP after recording has finished.

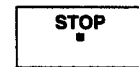

The edit mode will be also cancelled.

Recording from Compact Discs (continued)

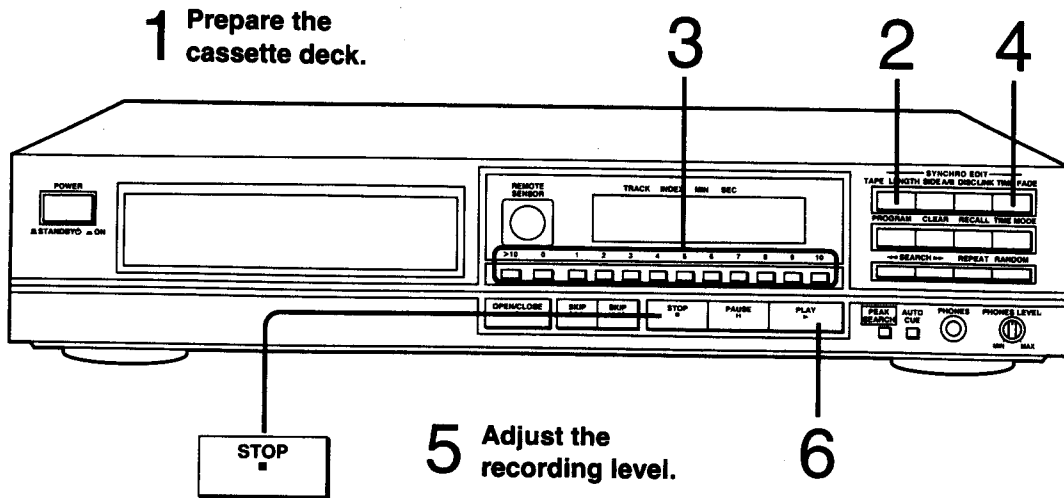

Fade out editing

You can enter an additional track and record them with the fade-out at the end of each side of the tape.

For example, to add track 3 on the remaining time and to set the fade-out on each tape side.

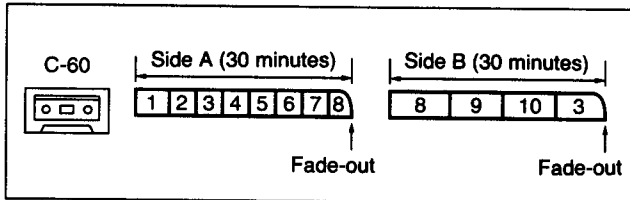

1 Prepare the cassette deck for recording.
(See page 21.)

2 Press TAPE LENGTH to select the tape length.
(See step 2 on page 20.)

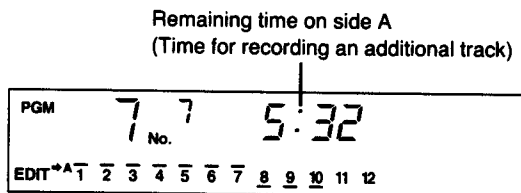

3 Enter the additional track to be recorded on the remaining time on side A.
(See page 23.)

For example, if you enter track 3:

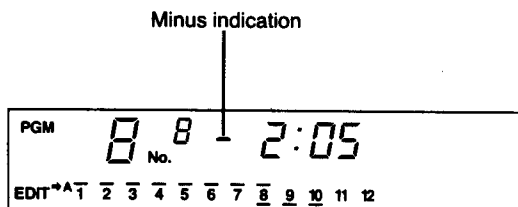

4 Press TIME FADE.

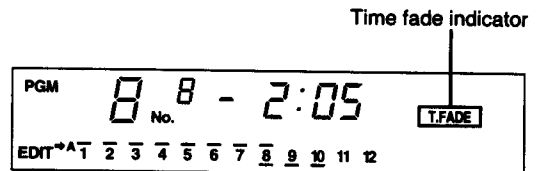

If you want to add a track on the remaining time on side B, press SIDE A/B then repeat steps 3 and 4.

5 Adjust the recording level on the cassette deck.
(Follow steps 3 and 4 on page 20.)

6 Press ► PLAY to start recording.

- Recording on the cassette deck will start at the same time.
- The fade-out begins 5 seconds before the end of the tape.

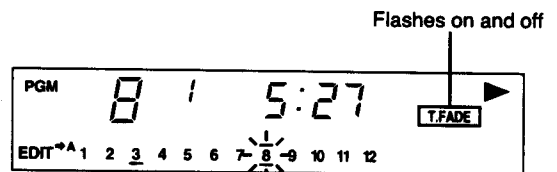

■ **To cancel the fade out editing**

Press ■ **STOP** after recording has finished.



The edit mode will also be cancelled.

Concerning Compact Discs

Only compact discs having this mark can be used with this unit.



Handling precautions

To open the case, gently press the sides of the top, holding the top at both sides.

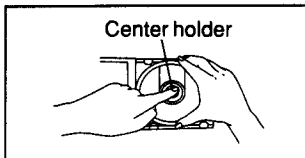
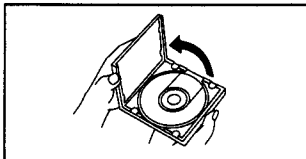

- To remove the disc from the case, press the center holder and lift the disc, holding by the edges.
- To store the disc to the case, insert the disc with label facing up and press downward at the center.
- Hold compact discs by the edges so the surface is not soiled with fingerprints. Fingerprints, dirt and scratches can cause skipping and distortion.

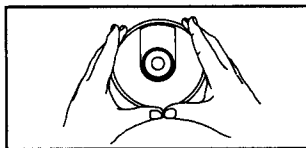
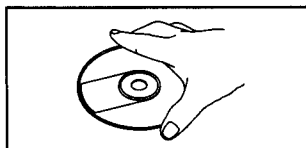

Do not use record cleaning sprays, benzine, thinner, static electricity prevention liquids or any other solvent.

If the surface is soiled, wipe gently with a soft, damp (water only) cloth.

Always move the cloth directly outward from the center of the disc, not in a circular motion as with standard phonograph records.

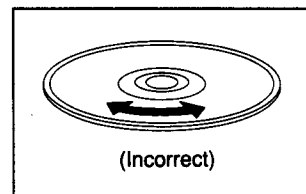
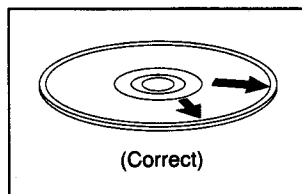

- If the disc is brought from a cold to a warm environment, moisture may form on the disc. Wipe this off with a soft, dry, lint-free cloth before using the disc.
- Do not write on the label side with a ball-point pen or other writing instrument.

Storage precautions

Be sure to store discs in their cases to protect them from dust, scratches and warping.

Do not place or store discs in the following places:

- 1) Locations exposed to direct sunlight.
- 2) Humid or dusty locations.
- 3) Locations directly exposed to a heat outlet or heating appliance.
- 4) In the glove compartment or rear ledge of an automobile.

Technical Specifications

■ Audio

No. of channels	2 (left and right, stereo)
Frequency response	2–20,000 Hz, ± 1 dB
Output voltage	2 V (at 0 dB)
Dynamic range	92 dB
S/N	100 dB
Total harmonic distortion	0.007% (1 kHz, 0 dB)
Wow and flutter	Below measurable limit
DA converter	MASH (1 bit)
Output impedance	Approx. 1 k Ω
Load impedance	More than 10 k Ω
Headphone output level	15 mW max. 32 Ω (adjustable)

■ Pickup

Wavelength	780 nm
------------	--------

■ General

Power consumption	
For Australia and New Zealand;	13 W
For others;	14 W
Power supply	
For Australia and New Zealand;	AC 50/60 Hz, 230–240 V
For others;	AC 50/60 Hz, 110 V/127 V/220 V/240 V
Dimensions (W×H×D)	430×102.6×283.4 mm
Weight	3.4 kg

Note:

Specifications are subject to change without notice.
Weight and dimensions are approximate.

Troubleshooting Guide

Before requesting service for this unit, check the chart below for a possible cause of the problem you are experiencing. Some simple checks or a minor adjustment on your part may eliminate the problem and restore proper operation.

If you are in doubt about some of the check points, or if the remedies indicated in the chart do not solve the problem, refer to the directory of Authorized Service Centers (enclosed with this unit) to locate a convenient service center, or consult your dealer for instructions.

Problem	Probable cause(s)	Suggested remedy
The disc in the unit will not play.	Moisture has condensed in the unit.	● Switch ON and allow the unit to dry out for about one hour before using the unit.
	The disc is upside down.	● Be sure the label is facing upward.
	The disc is dirty.	● Wipe the disc with a soft cloth.
	The disc is scratched.	● Replace the disc with a new disc.
	The disc is warped.	
	The disc is not within specified standards.	
A certain music passage won't play correctly.	The disc is dirty.	● Wipe the disc with a soft cloth.
	The disc is scratched.	● Replace the disc with a new one.
There is noise from the tuner or disturbance on the TV screen.	Caused by high-frequency signals of this unit.	● Use the changer farther away from the tuner or TV. ● If the tuner's or TV's antenna is the indoor type, use an outdoor one.
Remote control does not operate correctly.	The batteries are dead.	● Replace batteries with new ones.
	There is an obstruction between the remote control and the unit.	● Remove the obstruction.
	The batteries are inserted incorrectly. [The (+) and (-) polarities are reversed.]	● Reinsert batteries so that the polarities are correct.

Maintenance

To clean this unit, use a soft, dry cloth. If the surfaces are extremely dirty, use a soft cloth, dipped into a soap-and-water solution or weak detergent solution. Wring the cloth well before wiping the unit. Wipe once again with a soft, dry cloth.

Never use alcohol, paint thinner, benzene, nor a chemically treated cloth to clean this unit.

Such chemicals may damage the finish of your unit.

Matsushita Electric Industrial Co., Ltd.
Central P.O. Box 288, Osaka 530-91, Japan