



MODEL H7728 ROLLING TOOL CART INSTRUCTION SHEET

Introduction

This rolling tool cart with tool box requires some assembly. Follow the instructions under each **Figure** on the following page.

To begin, lay out all of the parts and compare quantities to the inventory list given below.

If you need additional help with these instructions, call our service department at: (570) 546-9663.

Inventory (Figure 1)

A.	Tool Box w/ Upper Shelf	1
B.	Side Support.....	2
C.	Bottom Shelf.....	1
D.	Vertical Support.....	4
E.	Handle	1
F.	Plain Caster.....	2
G.	Pivoting Caster.....	2
H.	8mm Hex Bolt.....	2
I.	8mm Carriage Bolt	22
J.	8mm Hex Nut	24
K.	6mm Phlps. Head Screw.....	16
L.	6mm Hex Nut	16
M.	8mm Flat Washer.....	24
N.	Front/Back Support	2
O.	Angle Bracket.....	4

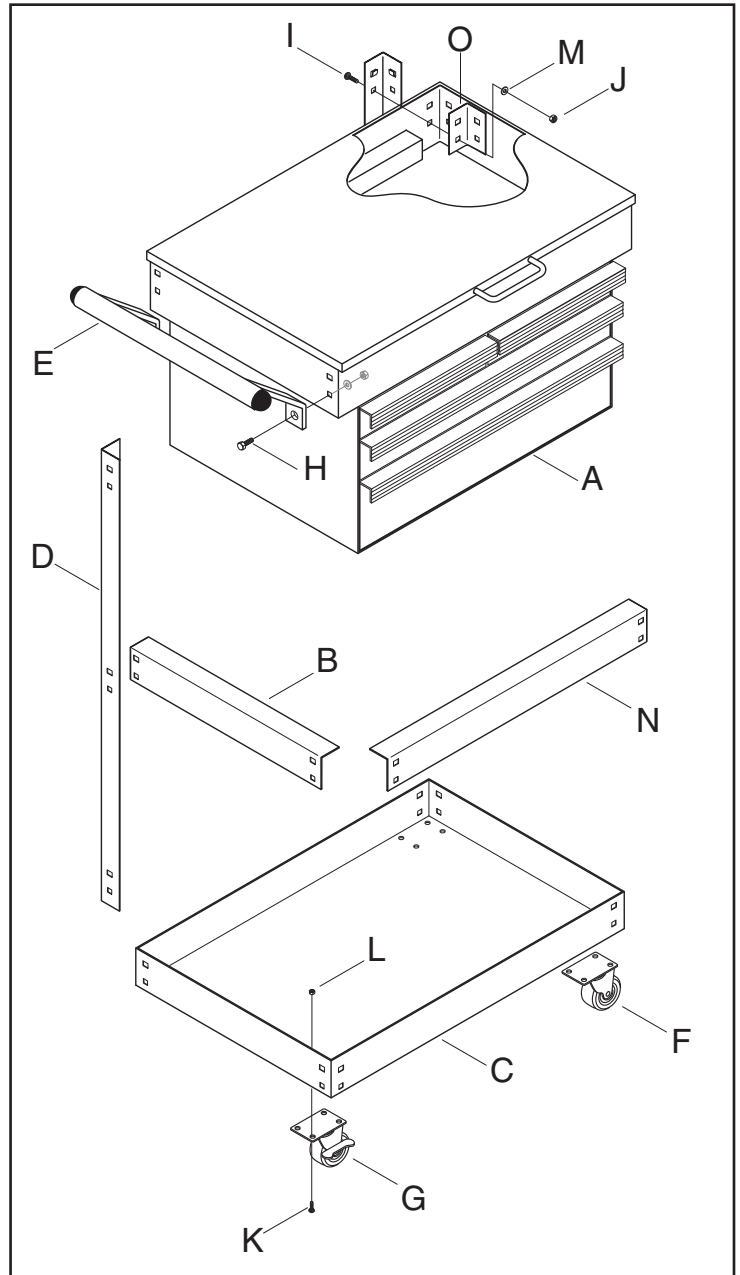

Figure 1. Inventory of parts.

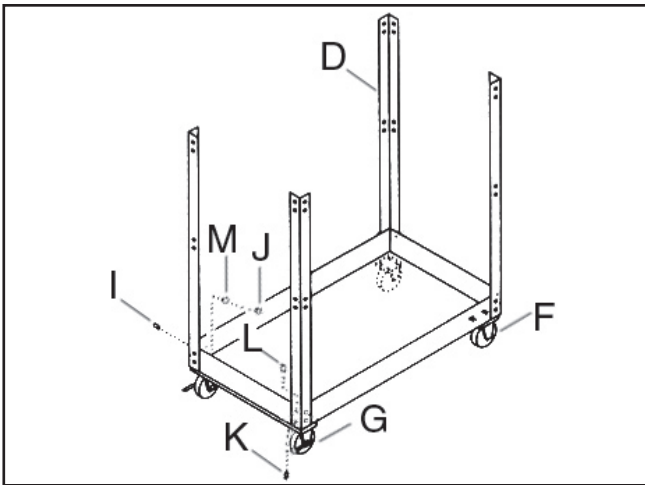

Figure 2. Assemble casters and vertical supports to bottom shelf.

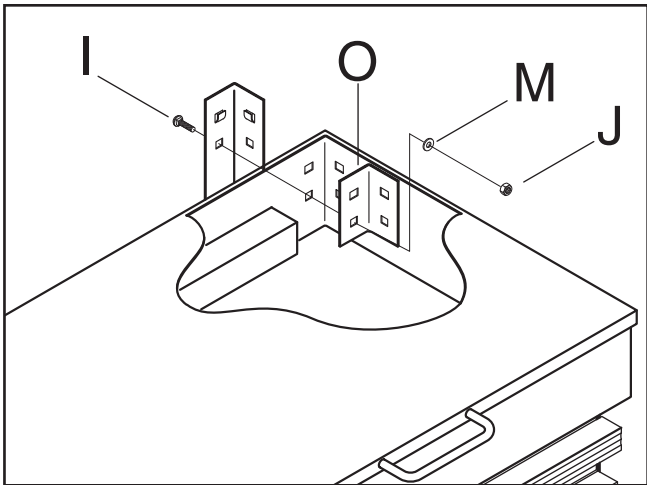

Figure 5. Details for assembly of the vertical support, the upper tray and the angle bracket.

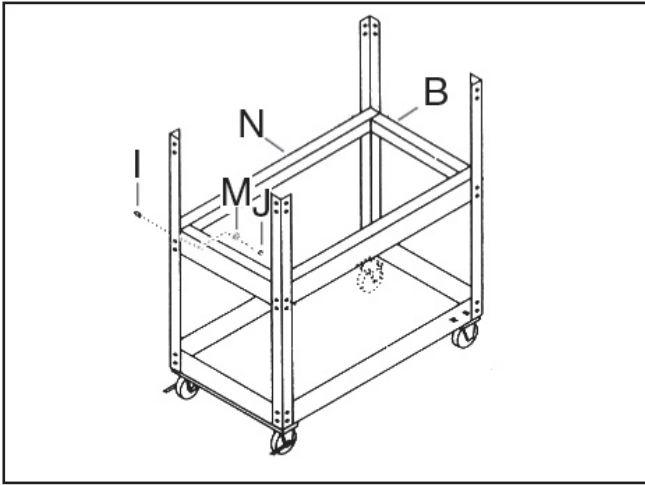

Figure 3. Assemble the side supports to the vertical supports.

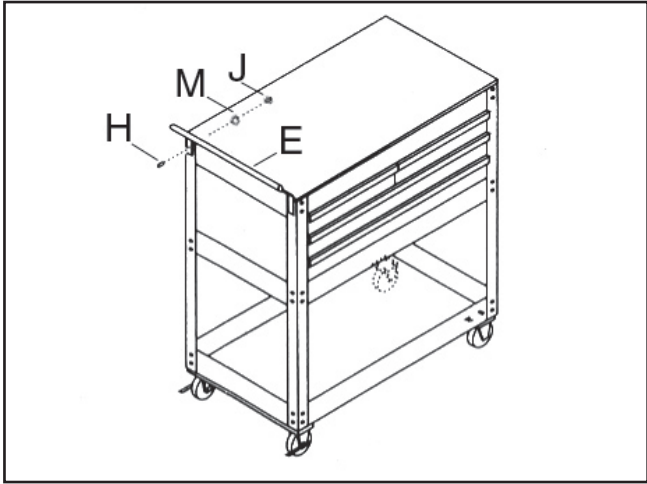

Figure 6. Assemble the handle onto the side of the tool box.

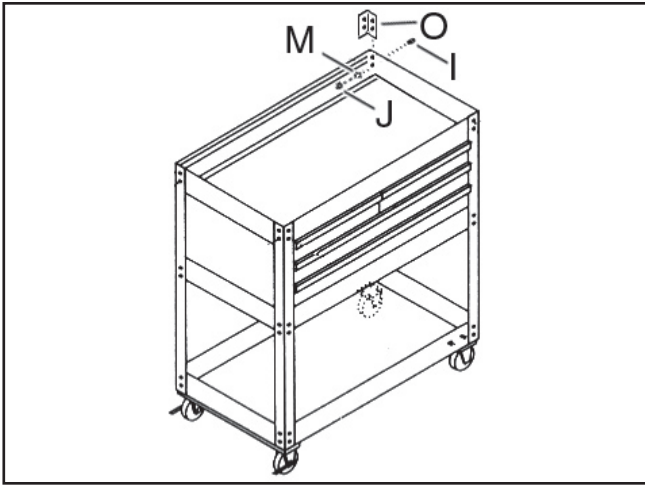

Figure 4. Set the tool box on top of the side supports and secure with screws, washers and nuts.