

CD Clock Radio

AJ3980



Read this manual first!
If you have any problems, do not attempt to return this product to the store.
For fast help, call us first!
1-800-531-0039



PHILIPS

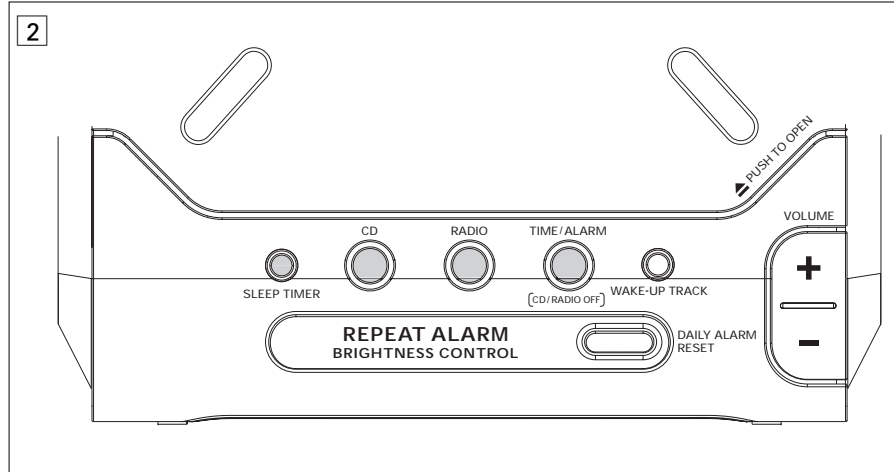
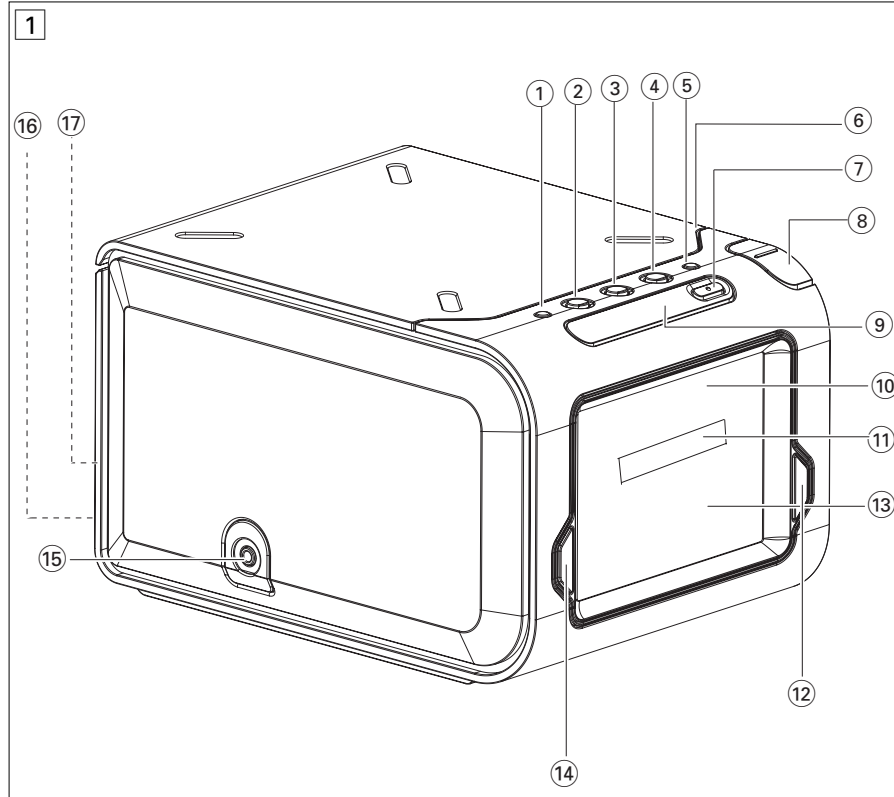

AJ3980 CD Clock radio

PHILIPS CONSUMER ELECTRONICS
NORTH AMERICA
Knoxville, Tennessee 37914-1810, U.S.A.

English

Français

Español

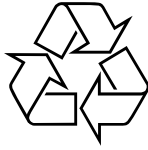

AJ3980



Meet Philips at the Internet
<http://www.philips.com>



Printed in China

3

TIME

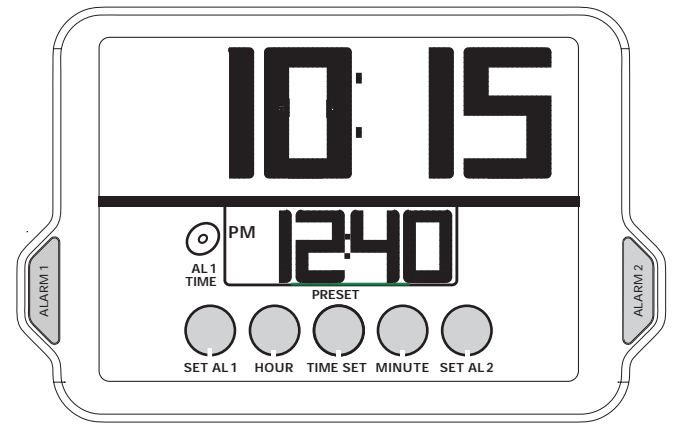

4

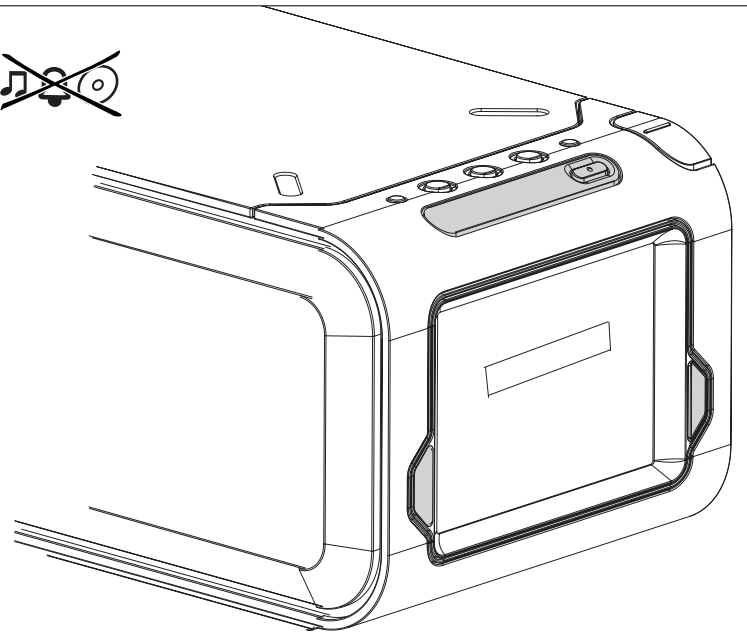

7

SLEEP TIMER

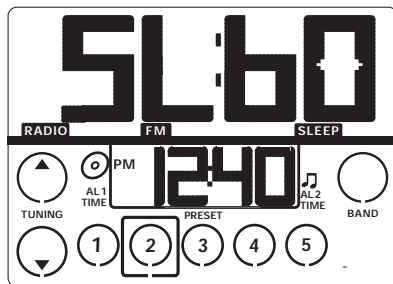
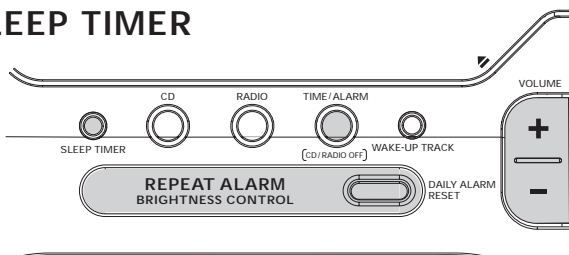

5

CD

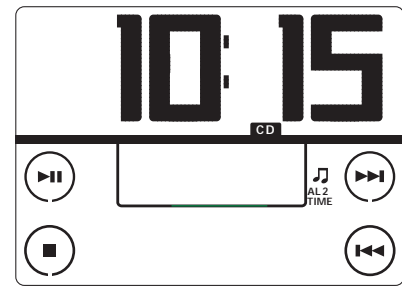
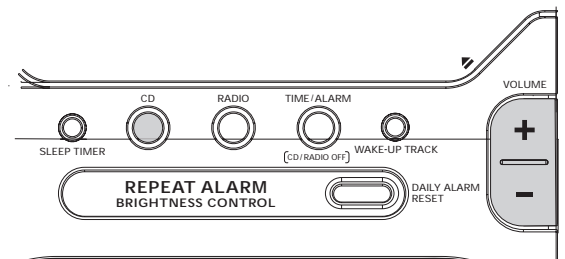

8

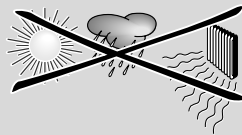

9

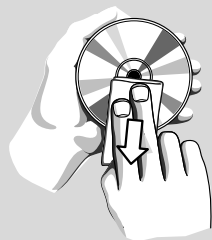

6

RADIO

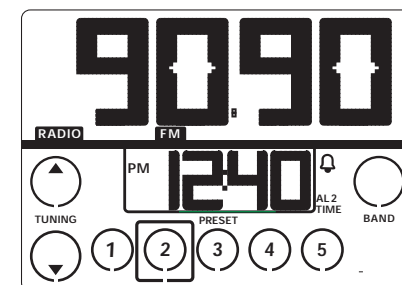
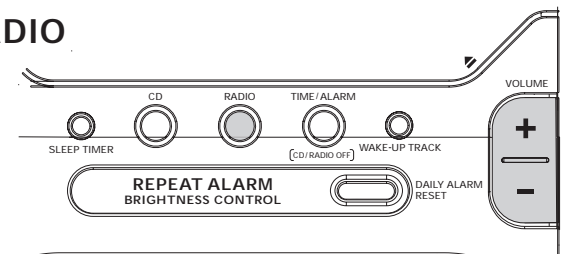

CONTROLS (see figure 1)

- ① **SLEEP TIMER** - adjusts timer options for CD / radio
- switches CD / radio on.
- ② **CD** - starts CD playback
- ③ **RADIO** - switches on radio
- ④ **TIME / ALARM**
[CD/RADIO OFF]
- switches off CD / radio
- selects clock display
- ⑤ **WAKE-UP TRACK** - programs your favorite CD track for wake-up track alarm.
- ⑥ **PUSH TO OPEN** - push this corner to open CD door
- ⑦ **DAILY ALARM RESET** - stops the active alarm for 24 hours
- ⑧ **+ / - VOLUME** - adjusts the volume
- ⑨ **REPEAT ALARM/ BRIGHTNESS CONTROL**
- switches off the alarm for a 9 minute period
- switches off timer function
- changes the brightness of the display window
- ⑩ **Main display**
- shows clock time and function status
- shows radio frequency and CD track number briefly when respective function is in use
- ⑪ **Alarm time display** - shows the alarm time and the chosen alarm activated:
- CD (AL 1 TIME), radio / buzzer (AL 2 TIME)
- ⑫ **ALARM 2**
- selects radio / buzzer alarm
- switches radio / buzzer alarm on/ off
- ⑬ **Touch Screen Controls**
Clock controls shown in standby mode. The radio / CD controls appear when the radio / CD is switched on.
SET AL 1 - sets CD alarm time
HOUR - adjusts hour setting
TIME SET - sets clock time
MINUTE - adjusts minute setting
SET AL 2 - sets radio / buzzer alarm

CD:

- starts / pauses CD playback
- stops CD playback
- / - skips to the next / previous CD tracks
- fast search within a track

Radio:

- TUNING** / (up / down)
- tunes to radio stations automatically/ manually
- PRESET** ① - ⑤ - to select / store a radio preset station
- BAND** - selects waveband (FM/AM).

⑭ ALARM 1

- selects CD alarm
- switches CD alarm on/ off

⑮ - 3.5 mm jack for headphones**⑯ Coil antenna** - improves FM reception**⑰ Power cord****INSTALLATION (see figure 2)****AC Power Supply**

1. Check if the power voltage, shown on the **type plate on the bottom of the set**, corresponds to your power supply. If it does not, consult your dealer or service center.

2. Connect the plug to the wall outlet.

...**PH...IL...IPS** scrolls across the display continuously.

- To exit the demo mode, press any button on the set.

Eg. TIME / ALARM [CD/RADIO OFF]

SLEEP TIMER

RADIO

CD

3. To disconnect the set completely from the power supply, withdraw the plug from the wall outlet.

Standby power consumption (clock mode)....1.5W

The serial and production number are located on the bottom of the set.

MEMORY BACKUP

The memory backup conveniently allows your clock, alarm and radio presets to be stored for up to 3 minutes when there is a power interruption e.g. AC power failure. The complete CD clock radio and display will be switched off. As soon as the power supply returns, the display will indicate the correct time.

- If power supply returns *after* 3 minutes, you will need to re-enter the clock and alarm time settings.

CONNECTING HEADPHONES

Connect headphones with a 3.5 mm plug into the jack.
→The built-in speaker will now be muted on the set.

DISPLAY BRIGHTNESS

In the dim / medium setting, the backlight is interactive and gently fades in and out whenever you press a touch screen control.

There are 3 settings: **bright** → **medium** → **dim**

- Press **REPEAT ALARM/ BRIGHTNESS CONTROL** once or more.

SETTING THE CLOCK TIME (see figure 3)

The time is displayed using the 12 hour clock where the **PM** indicator lights up (on = **PM**, off = **AM**).

1. In the standby mode, press **TIME SET** to activate the clock setting mode.

→The current clock time in the main display flashes.

2. Press **HOUR / MINUTE** to adjust the hours and minutes respectively.

- With your finger held down on **HOUR / MINUTE**, the display will increase the hours / minutes rapidly and continuously.

- Press **HOUR / MINUTE** briefly and repeatedly to adjust the time slowly.

3. Press **TIME SET** again when you have reached the correct time.

→You will hear a double beep to confirm the time setting.

SETTING THE ALARM (see figure 3)**GENERAL**

Two different alarm times, **ALARM 1** and **ALARM 2** can be set in the CD / radio / buzzer modes.

This can be useful when for example you need to be woken up at a different time during the week and at the weekend.

SETTING THE ALARM TIME

1. In the standby mode, press **ALARM 1 / ALARM 2** to select the alarm mode. Check the respective icon appears in the display: CD radio / buzzer .

Either press briefly:

- **ALARM 1** once for CD alarm . This enables CD playback from the first track as your alarm call.

- **ALARM 2** once or more for radio / buzzer alarm.

2. Press **SET AL 1** or **SET AL 2** to activate the alarm setting mode.

→The current alarm time display flashes.

3. Press **HOUR/ MINUTE** to adjust the hours and minutes respectively.

- With your finger held down on **HOUR/ MINUTE**, the display will increase the hours / minutes rapidly and continuously.

- Press **HOUR/ MINUTE** briefly and repeatedly to adjust the time slowly.

4. Press **SET AL 1** or **SET AL 2** again when you have reached the correct time.

→You will hear a double beep to confirm the time setting.

Alarm time display

If you have set both alarms, the standby alarm time display will show the alarm time which is ready to go off first, according to the current clock time.

E.g. if current **clock time = 7:30**

AL2 TIME = 6:20

AL 1 TIME = 7:45,

the standby alarm display shows the alarm time, **7:45**.

GENTLE WAKE VOLUME

A sure way of getting up in the mornings, the **gentle wake** volume for the alarm begins from a fixed gentle volume (1) and gradually increases to a maximum higher setting of (5).

- The default low volume is 0 : 1, and the maximum volume is 0 : 5.
- During the alarm call, if you press **+ / - VOLUME**, the volume stops automatically getting louder.

ALARM

Helpful Tip :

If you want the alarm to wake you up, **FIRST CHECK:**

- you have **disconnected the headphones.**
- **radio alarm : make sure you have tuned properly to a station.**

SELECTING CD WAKE-UP ALARM MODE

You can program and select a CD track number between 1-99, when the set is in the standby or radio playback mode.

However, if the track number programmed does not exist on your CD, the CD will start playback from the first track during the alarm call.

1. Set the alarm time for **AL1 TIME**.
 2. Insert a CD into the CD compartment.
 3. Press **ALARM 1** to select CD alarm mode.
 4. Press **WAKE-UP TRACK** to activate favorite track programming.
 5. Press **▶▶** or **◀◀** until the desired track number is shown.
 6. Press **WAKE-UP TRACK** to confirm the selected track number.
- The display returns to standby clock time.
7. If you want to review your programmed track number, press **WAKE-UP TRACK**.

IMPORTANT!

The **buzzer alarm option** will automatically replace the CD alarm if you have:

- inserted a CD incorrectly;
- inserted a damaged CD;
- forgotten to insert any CD;
- not closed the CD door properly.

SWITCHING OFF THE ALARM (see figure 4)

There are three ways of switching off the alarm. Unless you cancel the alarm completely, the **DAILY ALARM RESET** option will be automatically selected after 59 minutes, from the time your alarm time first sounds.

Helpful Tip

During an alarm call/ repeat alarm, only the **DAILY ALARM RESET, REPEAT ALARM/ BRIGHTNESS CONTROL and ALARM 1 or ALARM 2 and +/- VOLUME** controls on the set will operate.

CD

DAILY ALARM RESET

If you want the alarm mode to be stopped immediately but also wish to retain the same alarm setting for the following day:

- Press and hold **DAILY ALARM RESET**

→ You will hear a beep tone to confirm that the alarm reset has been activated.

REPEAT ALARM

This will repeat your alarm call at 9 minute intervals.

- During the alarm call, press **REPEAT ALARM/ BRIGHTNESS CONTROL**.

• Repeat as often as desired.

→ Your alarm mode indication **♪**, **⊙**, **Ⓚ** will flash throughout the time the repeat alarm is active.

CANCELLING THE ALARM COMPLETELY

When an alarm is cancelled this is shown by the selected alarm indication and symbol disappearing from the display.

To cancel the set alarm time *before it goes off:*

- Press **ALARM 1** or **ALARM 2** until the alarm icons **Ⓚ** / **♪** / **Ⓚ** disappears from the display.

CD PLAYBACK (see figure 5)

1. Insert a CD with the printed side facing up, and close the door.

2. Press the CD button to start playback.

→ Display shows: 'L d: - -' and the total number of tracks, then your current track number, before returning to clock time

→ CD touch screen controls appears throughout CD operation.

Other possible CD indications before returning to clock time:

→ **door** is shown if the CD door is not closed.

→ **no L d** is shown if no CD has been inserted / inserted incorrectly.

→ **nFL d** is shown if the CD-R(W) is non-finalized

→ **Err** indicates a general error in operation of the set.

3. Adjust the sound with **+/- VOLUME**.

4. To interrupt, press **▶▶**

→ **CD** flashes.

5. Press **▶▶** again to resume playback.

6. Press **■** to stop playback. Or press **TIME / ALARM [CD/RADIO OFF]** to return to standby mode.

CD / RADIO

Helpful Tip :

In the CD stop position, the **CD touch screen display** remains active for 5 minutes.

- Press **▶▶** to start playback again if you have stopped briefly e.g. to change a CD.

– If CD playback is paused for more than 15 minutes and no controls are pressed, the set automatically goes to standby mode.

SELECTING A DIFFERENT TRACK DURING PLAYBACK

The track number appears briefly in the display when you press **▶▶** or **◀◀** to skip tracks.

- Press **▶▶** once or more to skip to the next track(s).

- Press **◀◀** more than once to skip to previous tracks

- Press **◀◀** once and playback will return to the beginning of the current track.

FINDING A PASSAGE WITHIN A TRACK

1. During playback, press and hold **▶▶** or **◀◀**

→ The CD is played at high speed and low volume; the display will show 'L d:' and your current track number.

2. Release **▶▶** or **◀◀** when you recognize the passage you want.

→ Normal CD playback and standby clock time resumes.

RADIO RECEPTION (see figure 6)

1. Press the **RADIO** button to switch on the radio.

→ Radio touch screen controls appears throughout radio operation

→ The radio frequency and waveband appears in the display for 10 seconds before reverting back to the clock display.

2. Press the **BAND** button to select your waveband FM/AM.

3. Tune to your station **manually** or **automatically** by using **▲** / **▼** (up / down).

To improve reception :

FM : extend the coil antenna fully at the back of the set for optimum reception.

AM : uses a built-in antenna. Direct the antenna by adjusting the position of your set.

4. Adjust the sound using the **+ / - VOLUME**.

5. To switch off the radio, press the **TIME/ALARM [CD/RADIO OFF]** button.

SLEEP TIMER

TUNING TO A STATION (see figure 6)

Manual tuning:

1. Press **▲** / **▼** briefly to find your station. Repeat until you have found the desired station.

Automatic tuning:

- Press and hold **▲** / **▼** until the display frequency starts to change frequency.

- When a station of sufficient strength has been found, tuning will stop. Or you can stop the automatic tuning search by pressing either **▲** / **▼** again. Repeat until you have found the desired station.

PRESET STATIONS (see figure 6)

Storing preset stations

You can program up to five radio stations for each band. If you like, you can also replace a preset station with another frequency. The current station will be indicated by a square round the preset number in the display. E.g. **①**

1. Tune to your desired station (see **RADIO RECEPTION**).

2. As soon as you have found your station, press and hold a preset number **①-⑤**. Release the number when you hear a double beep confirming that the station has now been set.

Selecting preset stations

- Select and press a preset number, **①-⑤**.

SLEEP TIMER (see figure 7)

About SLEEP TIMER

This feature is a built-in timer device which enables the set to be automatically switched off during CD / radio playback, after a set period of time. There are three timer options: 60 , 30 and 15 minutes.

Setting SLEEP TIMER

1. Press the **SLEEP TIMER** button rapidly once or more to select your timer options: 60 , 30 and 15 minutes.

→ The display will show **SL** : and the timer options briefly.

→ **SLEEP** appears when the timer is active.

2. To cancel the timer, you can either press:

- **TIME/ALARM [CD/RADIO OFF]**

- **REPEAT ALARM/ BRIGHTNESS CONTROL**

MAINTENANCE

General (see figure 8)

- If you do not intend to use the set for a long time, withdraw the plug from the wall outlet.
- Do not expose the set, to humidity, rain, sand or excessive heat caused by heating equipment or direct sunlight.
- To clean the set, use a soft, dry cloth. Do not use any cleaning agents containing alcohol, ammonia, benzene or abrasives as these may harm the product's surface.

CD player and CD handling (see figure 9)

- The lens of the CD player should never be touched!
- Sudden changes in the surrounding temperature can cause condensation to form and the lens of your CD player to cloud over. Playing a CD is then not possible. Do not attempt to clean the lens but leave the set in a warm environment until the moisture evaporates.
- Always shut the CD door to keep the CD compartment dust-free. To clean, dust the compartment with a soft dry cloth.
- To clean the CD, wipe in a straight line from the center towards the edge using a soft, lint-free cloth. Do not use cleaning agents as they may damage the disc.
- Never write on a CD or attach any stickers to it.

TROUBLESHOOTING

If a fault occurs, first check the points listed below before taking the set for repair.

If you are unable to remedy a problem by following these hints, consult your dealer or service center.

WARNING:

Do not open the set as there is a risk of electric shock! Under no circumstances should you try to repair the set yourself, as this will invalidate the warranty.

No sound

- Volume not adjusted
- Adjust the **VOLUME**
- Headphones are connected
- Disconnect headphones

No reaction to any operation of the buttons

- Electrostatic discharge
- Disconnect the set from the power supply and reconnect the set after 5 minutes.

CD playback does not work

- CD badly scratched or dirty
- Replace/ clean CD
- Laser lens steamed up
- Wait until lens has adjusted to room temperature
- Laser lens dirty
- Clean lens by playing a CD lens cleaning disc
- CD-R(W) is non-finalized
- Use a finalized CD-R(W)

Occasional crackling sound during FM broadcast

- Weak signal
- Extend coil antenna fully

Continuous crackling/ hiss disturbance during AM broadcast

- Electrical interference from TVs, computers, fluorescent lamps, etc.
- Move set away from other electrical equipment

The alarm does not function

- Alarm mode not selected
- See chapter on SETTING THE ALARM
- Alarm time not set
- See chapter on SETTING THE ALARM.

CAUTION

Use of controls or adjustments or performance of procedures other than herein may result in hazardous radiation exposure or other unsafe operation.

Environmental information

All unnecessary packaging material has been omitted. We have done our utmost to make the packaging easily separable into 2 materials: paper pulp, polyethylene.

Your set consists of materials which can be recycled if disassembled by a specialized company. Please observe local regulations on the disposal of packing materials and old equipment.