

Installation

Derby Stallion Weight Mount Kit

Part No. 1846198

Instructions

For all Derby Stallion ZT2354 mowers

This kit is required when using the Triple Bag Collector #1693501 and Hitch & Tube Kit #1693791 grass collection system.

Kit Contents:

Part No.	Qty.	Description
1846169	1	Stallion Weight Mount Rack
1846174	1	Weight Retainer Rod
N/A	2	Hairpin Clip
N/A	2	Bolt, 3/8-16 x 2"
N/A	2	Nut, 3/8-16 Nylon Lock

⚠ WARNING

Before beginning any service work turn off the PTO, set the parking brake, turn off the ignition, and disconnect the spark plug wire(s).

INSTALLATION

1. Park machine on a flat, level surface and engage the parking brake.
2. Measure and mark the front main frame tubes to the dimensions shown in Figure 1. (1-1/4" down from the top of the tube, 3/4" in from the end of the tube.)
3. Using a 3/8" drill bit, drill one (1) hole in each of the main frame tubes from the outside surface of the tube.
4. Slide the weight mount rack into the main frame tubes and align with the holes drilled through the frame (see Figure 2). It may require you drive the arms into the frame tubes using a wooden block and hammer.
5. Finish drilling through the opposite wall of the frame tubes using the weight rack as a guide.
6. Install the 3/8" bolts and nuts and fasten securely.
7. Install the weight plates supplied with the grass collector on the weight mount rack (see Figure 3).
8. Install the weight retainer rod through the weight mount rack and secure with the hairpin clips (see Figure 3).
9. Reinstall the spark plug wires.

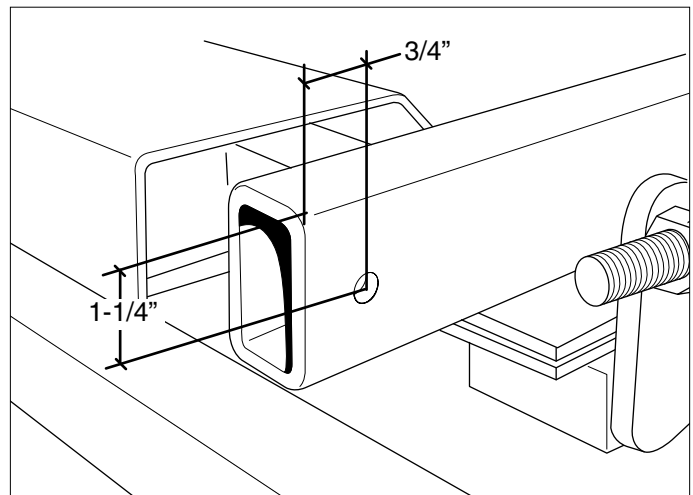

Figure 1. Hole Location

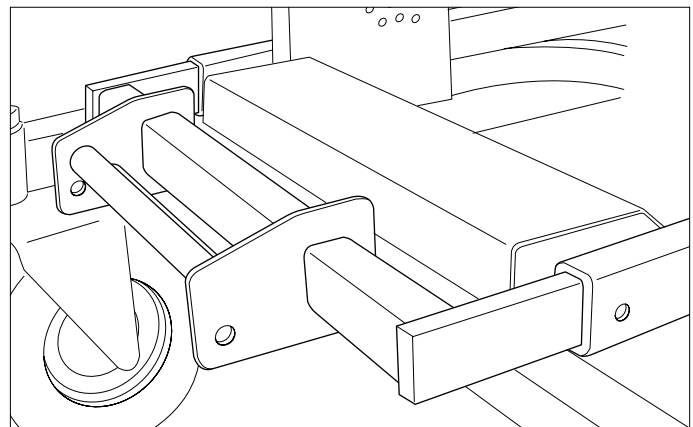

Figure 2. Weight Rack Installation

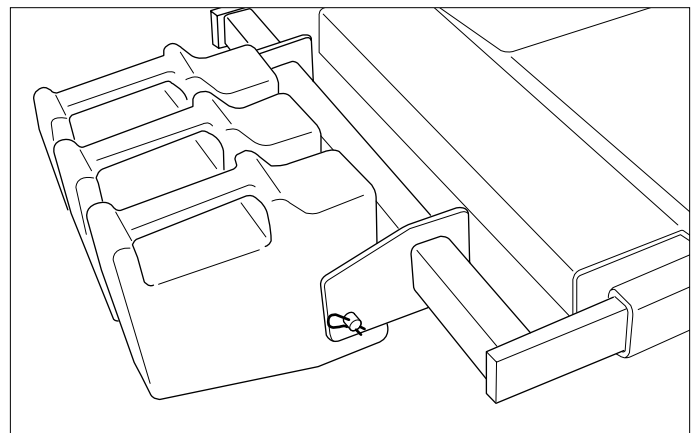

Figure 3. Weight & Retainer Rod Installation