

# Makita

## Cutter

110 mm (4-3/8") MODEL 4100NH

### INSTRUCTION MANUAL

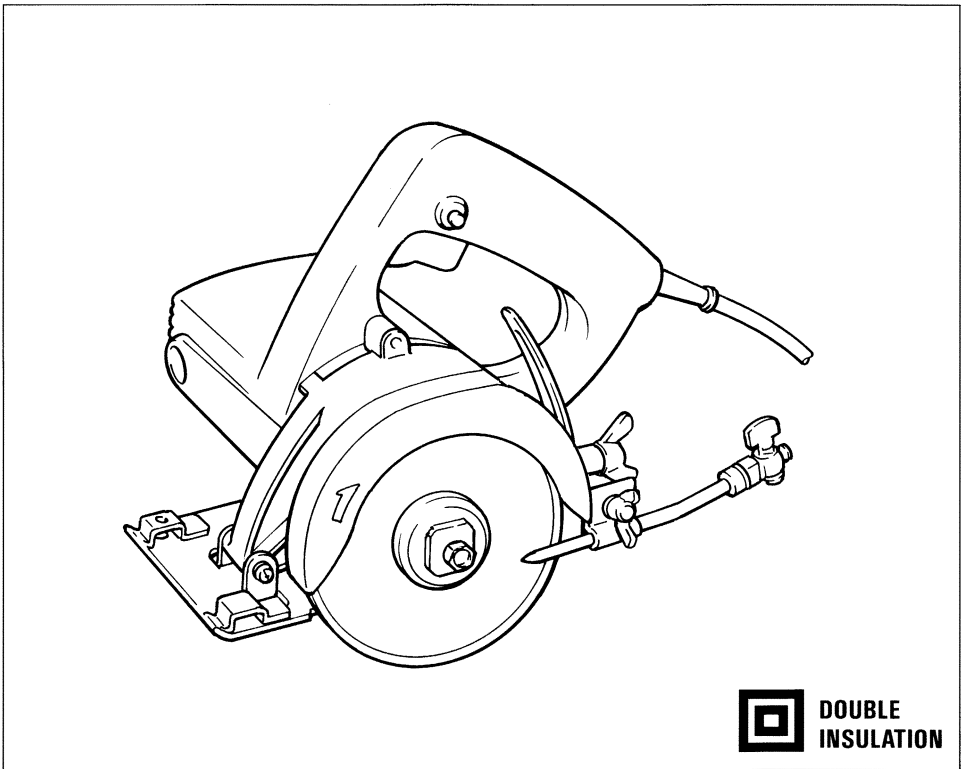

#### SPECIFICATIONS

Blade diameter	Hole diameter	Max. cutting capacity	No load speed (RPM)	Overall length	Net weight
110 mm (4-3/8")	20 mm (3/4")	34 mm (1-3/8")	13,000	218 mm (8-5/8")	2.7 kg (5.9 lbs)

\* Manufacturer reserves the right to change specifications without notice.

\* Note: Specifications may differ from country to country.

## IMPORTANT SAFETY INSTRUCTIONS

**WARNING:** When using electric tools, basic safety precautions should always be followed to reduce the risk of fire, electric shock, and personal injury, including the following:

### READ ALL INSTRUCTIONS.

1. **KEEP WORK AREA CLEAN.** Cluttered areas and benches invite injuries.
2. **CONSIDER WORK AREA ENVIRONMENT.** Keep work area well lit. Don't expose power tools to rain. Don't use tool in presence of flammable liquids or gases.
3. **KEEP CHILDREN AWAY.** All visitors should be kept away from work area. Don't let visitors contact tool or extension cord.
4. **STORE IDLE TOOLS.** When not in use, tools should be stored in dry, and high or locked-up place — out of reach of children.
5. **DON'T FORCE TOOL.** It will do the job better and safer at the rate for which it was intended.
6. **USE RIGHT TOOL.** Don't force small tool or attachment to do the job of a heavy-duty tool. Don't use tool for purpose not intended.
7. **DRESS PROPERLY.** Don't wear loose clothing or jewelry. They can be caught in moving parts. Rubber gloves and non-skid footwear are recommended when working outdoors. Wear protective hair covering to contain long hair.
8. **USE SAFETY GLASSES.** Also use face or dust mask if cutting operation is dusty.
9. **DON'T ABUSE CORD.** Never carry tool by cord or yank it to disconnect from receptacle. Keep cord from heat, oil, and sharp edges.
10. **SECURE WORK.** Use clamps or a vise to hold work. It's safer than using your hand and it frees both hands to operate tool.
11. **DON'T OVERREACH.** Keep proper footing and balance at all times.
12. **MAINTAIN TOOLS WITH CARE.** Keep tools sharp and clean for better and safer performance. Follow instructions for lubricating and changing accessories. Inspect tool cords periodically and if damaged, have repaired by authorized service facility. Inspect extension cords periodically and replace if damaged. Keep handles dry, clean, and free from oil and grease.
13. **DISCONNECT TOOLS.** When not in use, before servicing, and when changing accessories, such as blades, bits, cutters.
14. **REMOVE ADJUSTING KEYS AND WRENCHES.** Form habit of checking to see that keys and adjusting wrenches are removed from tool before turning it on.
15. **AVOID UNINTENTIONAL STARTING.** Don't carry tool with finger on switch. Be sure switch is OFF when plugging in.
16. **OUTDOOR USE EXTENSION CORDS.** When tool is used outdoors, use only extension cords intended for use outdoors and so marked.

17. **STAY ALERT.** Watch what you are doing, use common sense. Don't operate tool when you are tired.
18. **CHECK DAMAGED PARTS.** Before further use of the tool, a guard or other part that is damaged should be carefully checked to determine that it will operate properly and perform its intended function. Check for alignment of moving parts, binding of moving parts, breakage of parts, mounting, and any other conditions that may affect its operation. A guard or other part that is damaged should be properly repaired or replaced by an authorized service center unless otherwise indicated elsewhere in this instruction manual. Have defective switches replaced by authorized service center. Don't use tool if switch does not turn it on and off.
19. **GUARD AGAINST ELECTRIC SHOCK.** Prevent body contact with grounded surfaces. For example; pipes, radiators, ranges, refrigerator enclosures.
20. **REPLACEMENT PARTS.** When servicing, use only identical replacement parts.

**VOLTAGE WARNING:** Before connecting the tool to a power source (receptacle, outlet, etc.) be sure the voltage supplied is the same as that specified on the nameplate of the tool. A power source with voltage greater than that specified for the tool can result in **SERIOUS INJURY** to the user — as well as damage to the tool. If in doubt, **DO NOT PLUG IN THE TOOL**. Using a power source with voltage less than the nameplate rating is harmful to the motor.

## ADDITIONAL SAFETY RULES

1. **BE SURE TO USE AN EARTH-LEAKAGE CIRCUIT BREAKER.**
2. For additional protection against electric shock, be sure to **WEAR RUBBER GLOVES AND RUBBER BOOTS** during operation.
3. Check the wheel carefully for cracks or damage before operation. Replace cracked or damaged wheel immediately.
4. Use only flanges specified for this tool.
5. Be careful not to damage the spindle, flanges (especially the installing surface) or bolt. Damage to these parts could result in wheel breakage.
6. When using the water feed, be careful not to let water get into the motor. If water runs into the motor, an electric shock hazard may result.
7. Hold the tool firmly.
8. Keep hands away from rotating parts.
9. Make sure the wheel is not contacting the workpiece before the switch is turned on.
10. Wait until the wheel attains full speed before cutting.
11. Stop operation immediately if you notice anything abnormal.
12. Never attempt to cut with the tool held upside down in a vise. This can lead to serious accidents, because it is extremely dangerous.

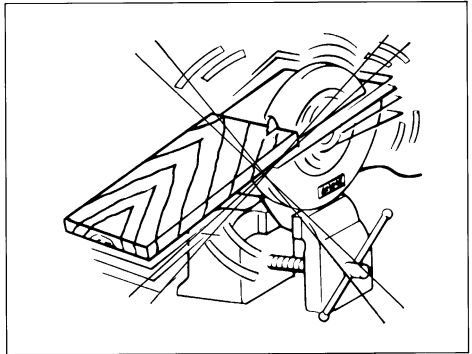

13. Before setting the tool down after completing a cut, be sure that the wheel has come to a complete stop.

**SAVE THESE INSTRUCTIONS.**

### Adjusting depth of cut

Loosen the wing bolt on the depth guide and move the base up or down. At the desired depth of cut, secure the base by tightening the wing bolt.

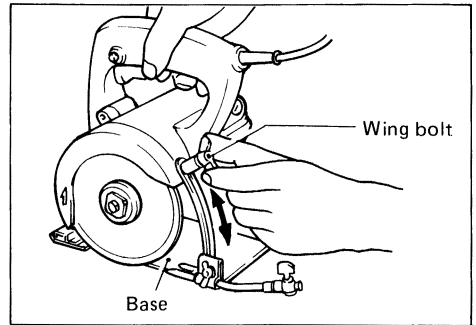

### CAUTION:

After adjusting the depth of cut, always tighten the wing bolt securely.

### Water flow

Loosen the wing bolt on the depth guide and move the base down.

Attach the vinyl tube onto the water pipe. Loosen the wing bolt which holds the pipe holder. Secure the water pipe with the pipe holder by tightening the wing bolt. Then attach the adapter on the vinyl tube to a faucet of water mains pressure. Adjust the amount of water flow by simply adjusting the water cock.

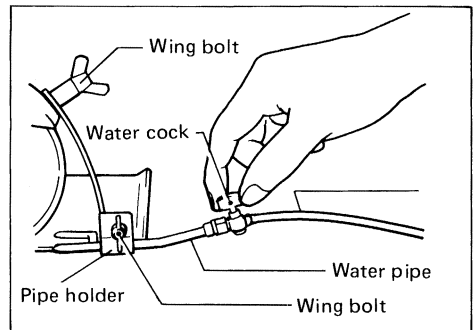

### CAUTION:

When adjusting depth of cut, also adjust the position of the water pipe. Otherwise the diamond wheel may damage the water pipe or the diamond when may not receive proper water flow.

### Switch action

To start the tool, simply pull the trigger. Release the trigger to stop. For continuous operation, pull the trigger and then push in the lock button. To stop the tool from the locked position, pull the trigger fully, then release it.

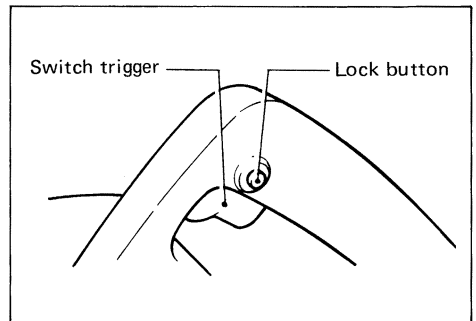

### CAUTION:

Before plugging in the tool, always check to see that the switch trigger actuates properly and returns to the "OFF" position when released.

### Sighting

Align the edge of the front of the base with your cutting line on the workpiece.

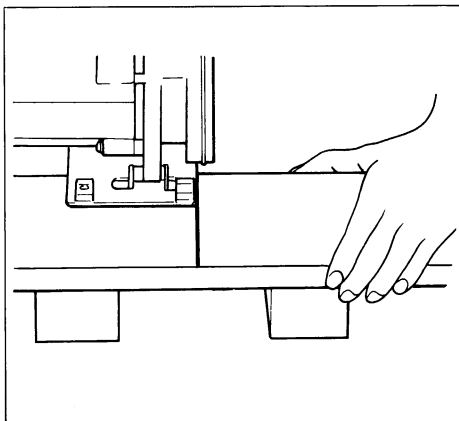

### Operation

Adjust the amount of water flow.

Hold the tool firmly. Set the base plate on the workpiece to be cut without the wheel making any contact. Then turn the tool on and wait until the wheel attains full speed. Now simply move the tool forward over the workpiece surface, keeping it flat and advancing smoothly until the cutting is completed. Keep your cutting line straight and your speed of advance uniform.

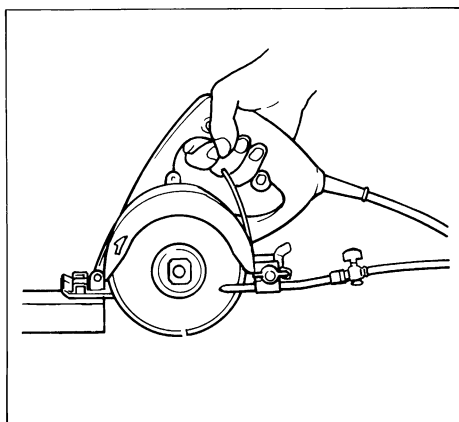

### CAUTION :

- THIS TOOL SHOULD ONLY BE USED ON HORIZONTAL SURFACES.
- Be sure to move the tool forward in a straight line and gently. Forcing and exerting excessive pressure or allowing the wheel to bend, pinch or twist in the cut can cause overheating of the motor and dangerous kickback of the tool.

### Removing or installing diamond wheel

**CAUTION:**

Always be sure that the tool is switched off and unplugged before removing or installing the wheel.

Hold the outer flange with the wrench and loosen the hex bolt clockwise with the socket wrench. Then remove the hex bolt, outer flange and wheel.

To install the wheel, follow the removal procedure in reverse.

Always install the wheel so that the arrow on the wheel points in the same direction as the arrow on the blade case.

**BE SURE TO TIGHTEN THE HEX BOLT SECURELY.**

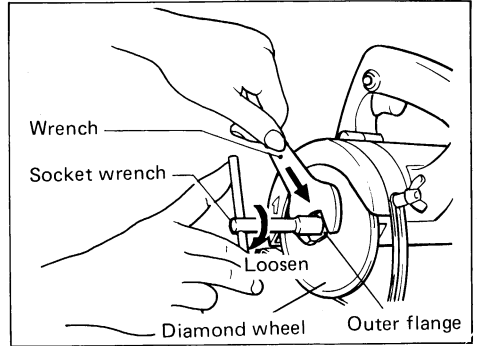

**CAUTION:**

Use only the Makita wrench and socket wrench to install or remove the wheel.

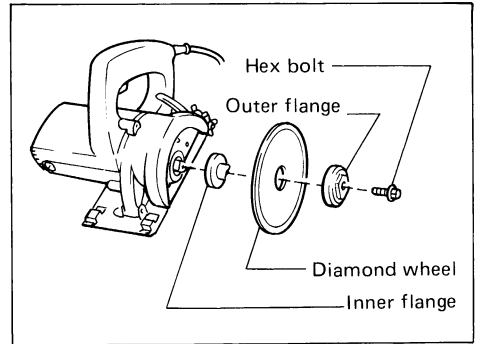

## MAINTENANCE

### CAUTION :

Always be sure that the tool is switched off and unplugged before attempting to perform inspection or maintenance.

### After use

Blow away dust from the inside of the tool by running the tool at an idle for a while.

Brush off accumulation of dust on the base.

Accumulation of dust in the motor or on the base may cause a malfunction of the tool.

### Replacing carbon brushes

Remove and check the carbon brushes regularly. Replace when they wear down to the limit mark. Keep the carbon brushes clean and free to slip in the holders. Both carbon brushes should be replaced at the same time. Use only identical carbon brushes.

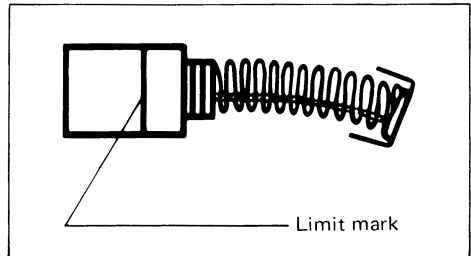

Use a screwdriver to remove the brush holder caps. Take out the worn carbon brushes, insert the new ones and secure the brush holder caps.

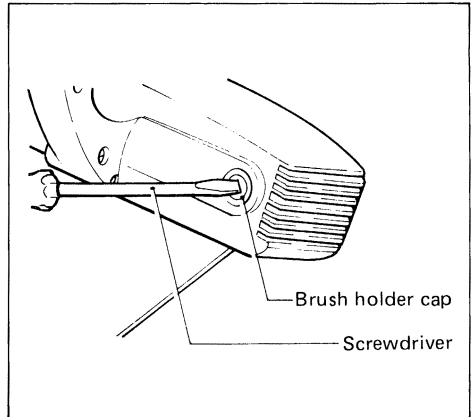

To maintain product SAFETY and RELIABILITY, repairs, any other maintenance or adjustment should be performed by Makita Authorized or Factory Service Centers, always using Makita replacement parts.



# ACCESSORIES

**CAUTION :**

These accessories or attachments are recommended for use with your Makita tool specified in this manual. The use of any other accessories or attachments might present a risk of injury to persons. The accessories or attachments should be used only in the proper and intended manner.

- **Socket wrench**  
Part No. 782209-3

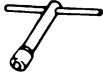

- **Wrench 22**  
Part No. 781011-1



- **Guide rule**  
Part No. 164095-8

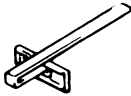

- **Diamond wheel**  
For all stone and masonry material, tiles etc.



A Type



B Type

Part No.	Diameter (mm)	Hole diameter (mm)	Blade type
792260-5	110 (4-3/8")	20 (3/4")	A (Dry)
792190-0			B (Wet)

- **Abrasive cut-off wheel**  
For all ferrous materials (steel, cast iron)  
Reinforced bond to reduce breakage.



Part No.	Diameter (mm)	Hole diameter (mm)	Wheels per pkg
* 792158-6	110 (4-3/8")	20 (3/4")	10
792159-4			10

Reinforced with 1 pc. of fiberglass.

\* Reinforced with 2 pcs. of fiberglass.

- **Abrasive cut-off wheel**  
For cutting masonry materials, brick, slate, concrete, etc.  
Reinforced bond to reduce breakage.



Part No.	Diameter (mm)	Hole diameter (mm)	Wheels per pkg
792153-6	10 (4-3/8")	20 (3/4")	10

Reinforced with 2 pcs. of fiberglass.





Makita Corporation

883887B988