

BLACK & DECKER[®]

www.blackanddecker.co.uk

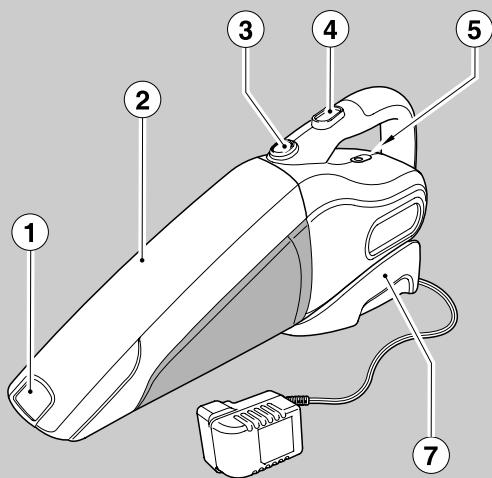
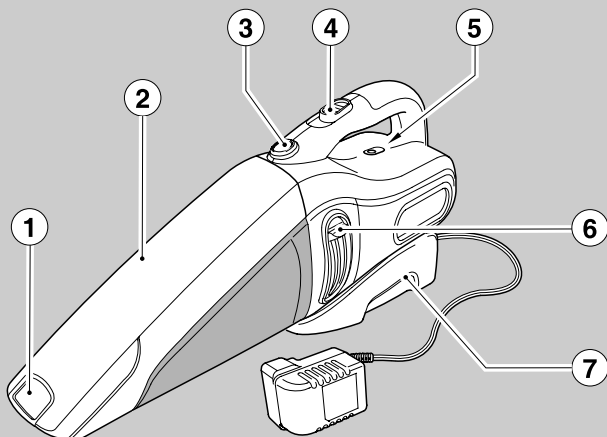

UK

Ireland

Australia

New Zealand

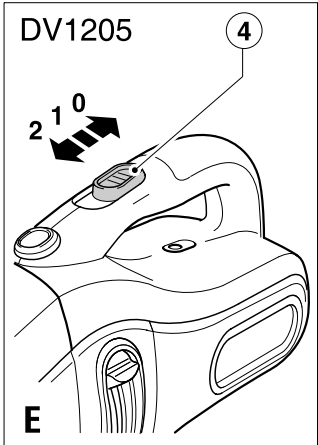
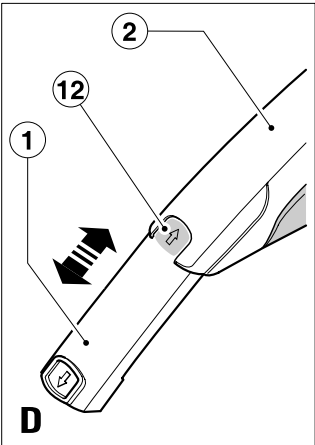
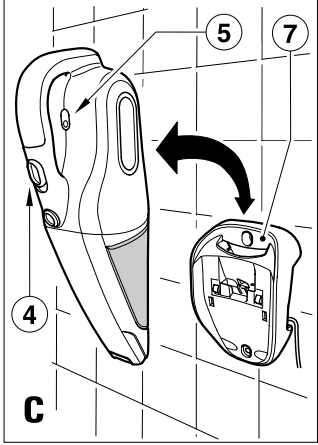
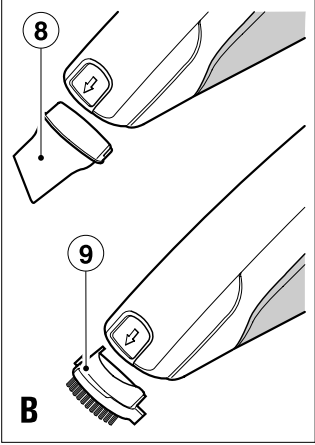
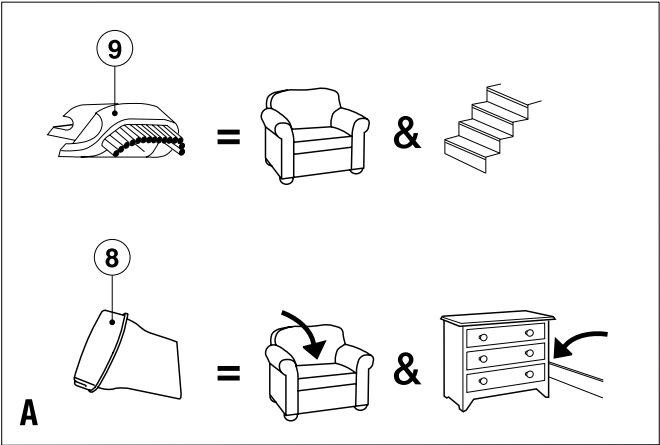

DV6005
DV7205
DV9605

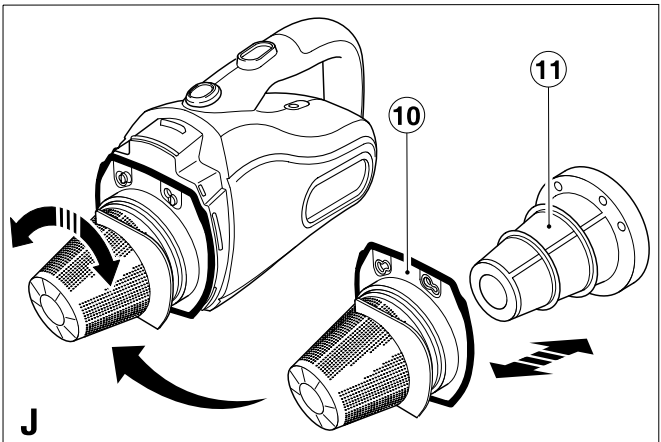
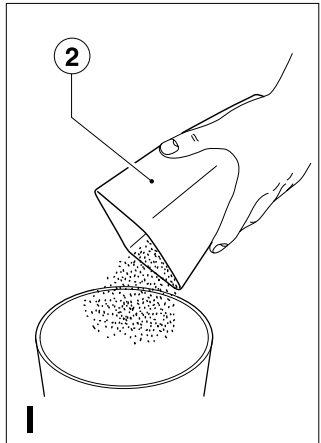
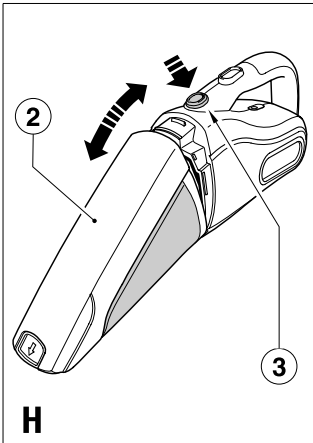
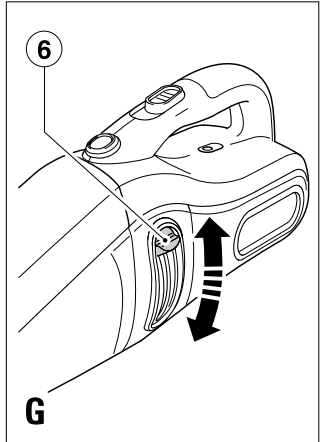
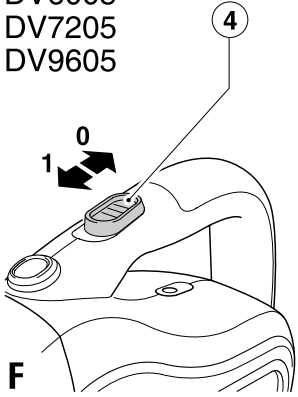

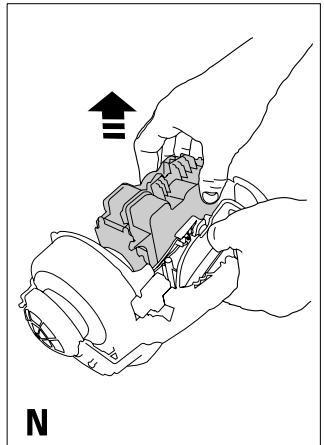
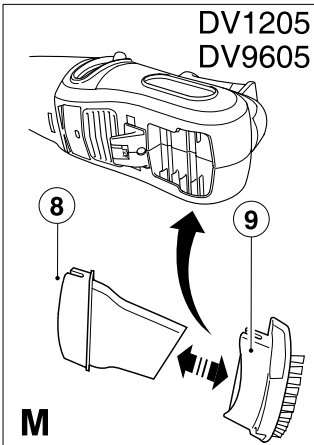
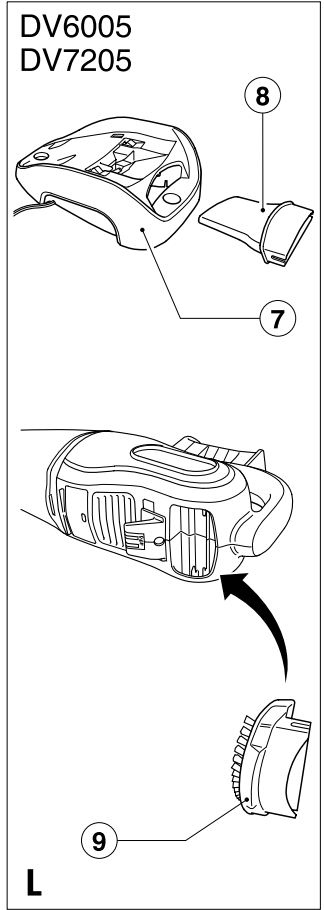
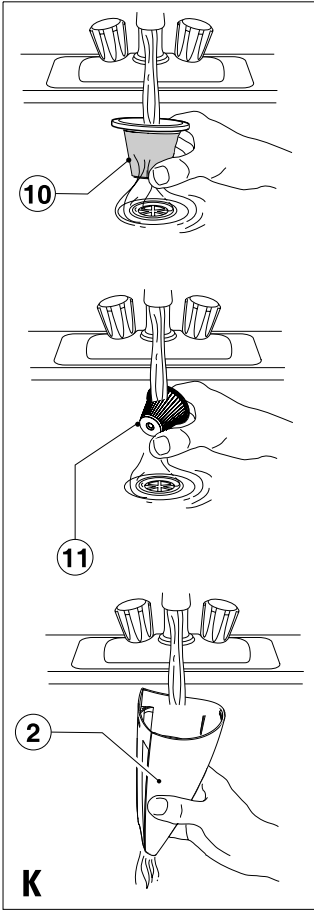

Intended use

Your Black & Decker Dustbuster® hand-held vacuum cleaner has been designed for light dry vacuum cleaning purposes. This appliance is intended for household use only.

Design and Patent information

EC Design Registration Numbers:

- ◆ 607643-0001
- ◆ 607668-0001
- ◆ 607650-0001

Safety instructions

Warning! When using battery-powered appliances, basic safety precautions, including the following, should always be followed to reduce the risk of fire, leaking batteries, personal injury and material damage.

- ◆ Read all of this manual carefully before using the appliance.
- ◆ The intended use is described in this manual. The use of any accessory or attachment or the performance of any operation with this appliance other than those recommended in this instruction manual may present a risk of personal injury.
- ◆ Retain this manual for future reference.

Using your appliance

- ◆ Do not use the appliance to pick up liquids or any materials that could catch fire.
- ◆ Do not use the appliance near water.
- ◆ Do not immerse the appliance in water.
- ◆ Never pull the charger lead to disconnect the charger from the socket. Keep the charger lead away from heat, oil and sharp edges.
- ◆ This appliance is not intended for use by young or infirm persons without supervision. Children must be supervised to ensure they do not play with the appliance.

After use

- ◆ Unplug the charger before cleaning the charger or charging base.

- ◆ When not in use, the appliance should be stored in a dry place.
- ◆ Children should not have access to stored appliances.

Inspection and repairs

- ◆ Before use, check the appliance for damaged or defective parts. Check for breakage of parts, damage to switches and any other conditions that may affect its operation.
- ◆ Do not use the appliance if any part is damaged or defective.
- ◆ Have any damaged or defective parts repaired or replaced by an authorized repair agent.
- ◆ Regularly check the charger lead for damage. Replace the charger if the lead is damaged or defective.
- ◆ Never attempt to remove or replace any parts other than those specified in this manual.

Battery and charger

- ◆ Never attempt to open the battery.
- ◆ Do not expose the battery to water.
- ◆ Do not incinerate the battery.
- ◆ Do not expose the charging base to water.
- ◆ Do not open the charging base.

Electrical safety

Your charger has been designed for a specific voltage. Always check that the mains voltage corresponds to the voltage on the rating plate. Never attempt to replace the charger unit with a regular mains plug.

Symbols on the charger



Read all of this manual carefully.



Your charger is double insulated; therefore no earth wire is required.



Fail-safe isolating transformer. The mains supply is electrically separated from the transformer output.



The charger automatically shuts off if the ambient temperature becomes too high. As a consequence the charger will be inoperable. The charging base must be disconnected from the mains supply and taken to an authorised service centre for repair.



The charging base is intended for indoor use only.

Features

1. Dust collector extension
2. Dust collector
3. Release button
4. On/Off switch
(two-speed switch DV1205)
5. Charging indicator
6. Filter cleaning button (DV1205 & DV9605)
7. Charging base

Fig. A

8. Crevice tool
9. Brush tool

Identifying your product

The model design can be determined from the suffix codes used in the catalogue number. The following catalogue numbers are described in this manual:

- ◆ DV60XXY/DV72XXY/DV96XXY/DV12XXY.

The suffix code XX corresponds to the following designs:

- ◆ 05: All units, supplied with a small crevice tool and a brush tool.

The suffix code Y is used to identify the range of colour/finish options.

The suffix code Y represented by the letter N is used for models fitted with a NiMH battery.

The suffix code Y represented by the letter H is used for models fitted with a HEPA filter.

Installation

Fitting the charging base to the wall

The charging base can be placed on a work top or fitted to the wall to provide a convenient storage and charging point for the appliance.

When fixing to a wall, make sure that the fixing method is suitable for the wall type and is appropriate to the weight of the appliance.

Assembly

Fitting the accessories (fig. A & B)

These models are supplied with some or all of the following accessories:

- ◆ A crevice tool (8) for confined spaces.
- ◆ A brush tool (9) for furniture and stairs.

To fit an accessory, proceed as follows:

- ◆ Take the accessories from its storage position on the appliance or charging base (7) (fig. L & M).
- ◆ Insert the appropriate accessory into the front of the appliance.

Use

- ◆ Before first use, the battery must be charged for at least 16 hours.
- ◆ Place the appliance on the charging base whenever it is not in use.

Charging the battery (fig. C)

Before charging the battery:

- ◆ Make sure that the dust collector extension (1) is pushed back into the dust collector (2).
- ◆ Make sure that the appliance is switched off. The battery will not be charged with the on/off switch (4) in the on position.
- ◆ Place the appliance on the charging base (7) as shown.
- ◆ Plug in the charger. Switch on at the mains.

The charging indicator (5) will be lit.

- ◆ Leave the appliance to charge for at least 16 hours.

While charging, the charger may become warm. This is normal and does not indicate a problem. The appliance can be left connected to the charger indefinitely. The charging indicator (5) will be lit as long as the appliance is connected to the plugged-in charger.

Warning! Do not charge the battery at ambient temperatures below 4 °C or above 40 °C.

Adjusting the dust collector (fig. D)

- ◆ Extend the dust collector (2) by pulling the dust collector extension (1) until it locks into position.
- ◆ Retract the dust collector extension (1) by pressing the area (12) marked with an arrow and pushing the dust collector extension (1) back into the dust collector (2).

Switching on and off (fig. E & F)

- ◆ To switch the appliance on, slide the on/off switch (4) forward.
- ◆ To switch the appliance off, slide the on/off switch (4) back.

DV1205 & DV9605 - Optimising the suction force (fig. G)

In order to keep the suction force optimised, the filters must be cleared regularly during use.

- ◆ Slide the filter cleaning button (6) up and down a few times to shake out dust clogging the filters (10 & 11).

Cleaning and maintenance

Warning! Regularly clean the filters (10 & 11).

Cleaning the dust collector and filters (fig. H - K)

The filters are re-usable and should be cleaned regularly.

- ◆ Press the release button (3) and remove the dust collector (2).
- ◆ Empty the dust collector (2) (fig. I).
- ◆ Remove the filters (10 & 11) by twisting them clockwise (fig. J).
- ◆ Separate the filters (10 & 11)
- ◆ Brush any loose dust from the filters (10 & 11).

- ◆ Wash the filters in warm, soapy water (fig. K). The dust collector (2) can also be washed if necessary.

Warning! Do not immerse the appliance in water.

- ◆ Make sure that the dust collector (2) and the filters (10 & 11) are dry.
- ◆ Refit the filters (10 & 11) on to the appliance, twisting them counter-clockwise until they lock into place.
- ◆ Refit the dust collector (2) onto the appliance. Make sure that the dust collector clicks into place.

Warning! Never use the appliance without the filters. Optimum dust collection will only be achieved with clean filters.

Replacing the filters

The filters should be replaced every 6 to 9 months and whenever worn or damaged. Replacement filters are available from your Black & Decker dealer (cat. no. VF70, VF80 for HEPA filters):

- ◆ Remove the old filters as described above.
- ◆ Fit the new filters as described above.

Storing the accessories (fig. L & M)

- ◆ Press the accessories into the corresponding holders until they click into place.

Protecting the environment



Separate collection. This product must not be disposed of with normal household waste.

Should you find one day that your appliance needs replacement, or if it is of no further use to you, think of the protection of the environment. Black & Decker repair agents will accept old Black & Decker tools and ensure that they are disposed of in an environmentally safe way.



Separate collection of used products and packaging allows materials to be recycled and used again. Re-use of recycled materials helps prevent environmental pollution and reduces the demand for raw materials.

Local regulations may provide for separate collection of electrical products from the household, at municipal waste sites or by the retailer when you purchase a new product.

Black & Decker provides a facility for the collection and recycling of Black & Decker products once they have reached the end of their working life. To take advantage of this service please return your product to any authorised repair agent who will collect them on our behalf.

You can check the location of your nearest authorised repair agent by contacting your local Black & Decker office at the address indicated in this manual. Alternatively, a list of authorised Black & Decker repair agents and full details of our after-sales service and contacts are available on the Internet at: **www.2helpU.com**.

Battery (fig. N)



If you want to dispose of the product yourself, the battery must be removed as described below and disposed of in accordance with local regulations.

- ◆ Preferably discharge the battery by operating the appliance until the motor stops.
- ◆ Press the release button (3) and remove the dust collector (2).
- ◆ Remove the filters (10 & 11) by twisting them clockwise (fig. J).
- ◆ Remove the seven screws holding the body of the appliance together.
- ◆ Pull the cover half away from the location half.
- ◆ For catalogue numbers DV60XXY & DV72XXY,

- lift out the full motor/fan/battery assembly.
- ◆ For catalogue numbers DV96XXY & DV12XXY,
 - prise the small cover from the filter cleaning slider and remove the slider securing screw.
 - lift out the full motor/fan/battery assembly
- ◆ Unplug the battery assembly from the main assembly.
- ◆ Place the battery in a suitable packaging to ensure that the terminals cannot be short-circuited.
- ◆ Take the battery to your service agent or to a local recycling station.

Once removed, the battery cannot be refitted.

Technical data

		DV60XXY	DV72XXY
Voltage	Vdc	6.0	7.2
Battery type		NiCd/NiMH	NiCd/NiMH
Weight	kg	0.9	1.0

		DV96XXY	DV12XXY
Voltage	Vdc	9.6	12.0
Battery type		NiCd/NiMH	NiCd/NiMH
Weight	kg	1.3	1.4

Charger

Input voltage	Vac	230
Approx. charging time (minimum)	h	16

EC declaration of conformity

DV60XXY, DV72XXY, DV96XXY,
DV12XXY

Black & Decker declares that these
products conform to:

2006/95/EC, EN 55014, EN60335,
EN 61000

Level of sound pressure, measured
according to EN60704-1: <70 dB(A),



Kevin Hewitt
Director of Consumer Engineering
Spennymoor, County Durham
DL16 6JG,
United Kingdom
22-08-2007

Guarantee

Black & Decker is confident of the quality of its products and offers an outstanding guarantee. This guarantee statement is in addition to and in no way prejudices your statutory rights. The guarantee is valid within the territories of the Member States of the European Union and the European Free Trade Area.

If a Black & Decker product becomes defective due to faulty materials, workmanship or lack of conformity, within 24 months from the date of purchase, Black & Decker guarantees to replace defective parts, repair products subjected to fair wear and tear or replace such products to make sure of the minimum inconvenience to the customer unless:

- ◆ The product has been used for trade, professional or hire purposes.
- ◆ The product has been subjected to misuse or neglect.
- ◆ The product has sustained damage through foreign objects, substances or accidents.
- ◆ Repairs have been attempted by persons other than authorised repair agents or Black & Decker service staff.

To claim on the guarantee, you will need to submit proof of purchase to the seller or an authorised repair agent. You can check the location of your nearest authorised repair agent by contacting your local Black & Decker office at the address indicated in this manual. Alternatively, a list of authorised Black & Decker repair agents and full details of our after-sales service and contacts are available on the Internet at:

www.2helpU.com

Please visit our website

www.blackanddecker.co.uk to register your new Black & Decker product and to be kept up to date on new products and special offers. Further information on the Black & Decker brand and our range of products is available at **www.blackanddecker.co.uk**.

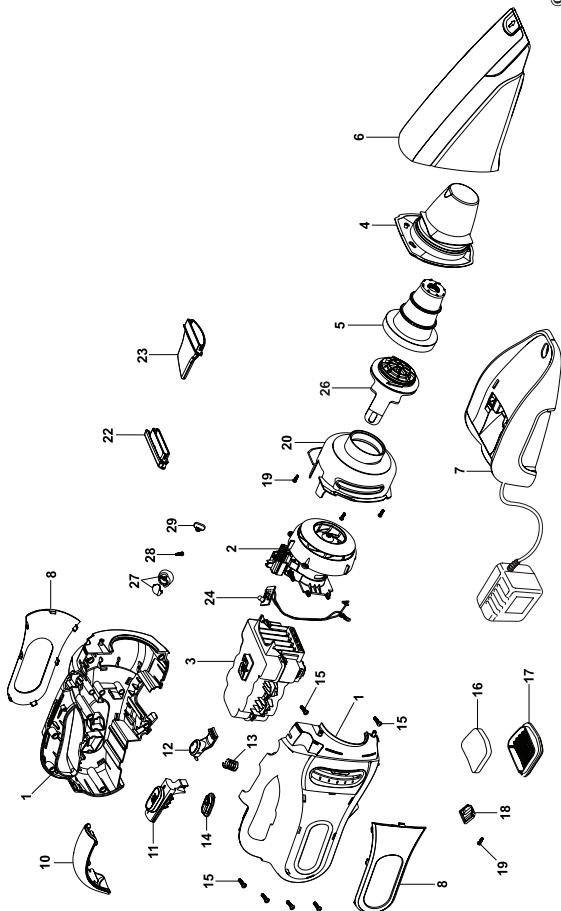

Australia	Black & Decker (Australia) Pty. Ltd. 20 Fletcher Road, Mooroolbark, Victoria, 3138	Tel. Fax	03-8720 5100 03-9727 594065
New Zealand	Black & Decker 81 Hugo Johnston Drive Penrose, Auckland, New Zealand	Tel. Fax	09 579 7600 09 579 8200
United Kingdom	Black & Decker 210 Bath Road Slough, Berkshire SL1 3YD	Tel. Fax Helpline	01753 511234 01753 551155 01753 574277