



## INSTALLATION INSTRUCTIONS FOR PART 99-1003

### APPLICATIONS

**KIA**  
**Rio 2001**  
**Sephia 1995-2001**  
**Spectra 2000-2001**  
**Sportage 1995-2003**

# 99-1003

#### KIT FEATURES

- DIN Radio Provision



#### KIT COMPONENTS

- A) Radio Housing #1 • B) Radio Housing #2 • C) Mounting Brackets • D) (4) Captive Studs  
• E) (4) Pal Nuts

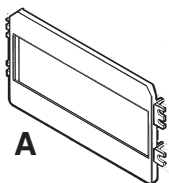

A

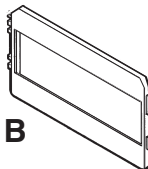

B

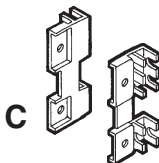

C



D



E

#### WIRING AND ANTENNA CONNECTIONS

(Sold Separately)

- 70-1003 - KIA Harness 1995-02
- Antenna Adapter N/R

#### TOOLS REQUIRED:

Panel Removal Tool • Cutting Tool • Phillips Screwdriver



1-800-221-0932



[www.metraonline.com](http://www.metraonline.com)

© COPYRIGHT 2004-2009 METRA ELECTRONICS CORPORATION



**TABLE OF CONTENTS**

**Dash Disassembly**

- *Kia Rio 2001* ..... 1
- *Sephia 1995-1997* ..... 2
- *Sephia 1998-2001* ..... 3
- *Spectra 2000-2001*..... 3
- *Sportage 1995-1997* ..... 4
- *Sportage 1998-2000* ..... 5
- *Sportage 2001-2003* ..... 6

**Kit Assembly**

- *Kit Assembly Preparation* ..... 7
- *DIN Radio Provision* ..... 8

- **Final Assembly** ..... 9

**\*Note:**

**Refer also to the instructions included with the aftermarket radio.**

**RIO 2001**

*\*Note: Refer also to the instructions included with the aftermarket radio.*

- 1 Disconnect the negative battery-terminal to prevent an accidental short circuit.
- 2 Remove ashtray and (1) Phillips head screw inside ashtray cavity. (Figure A)
- 3 Remove knob from climate control slide lever. (Figure B)
- 4 Unsnap and remove radio/climate control trim panel. (Figure C)
- 5 Remove (4) Phillips head screws securing the radio. Unplug and remove the radio.

*Continue to kit preparation.*

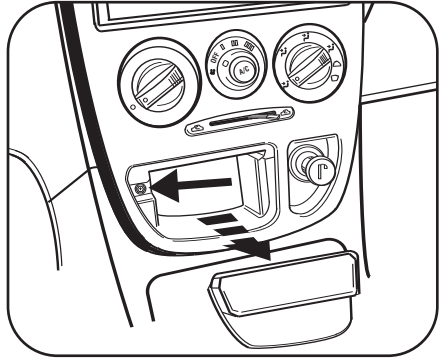
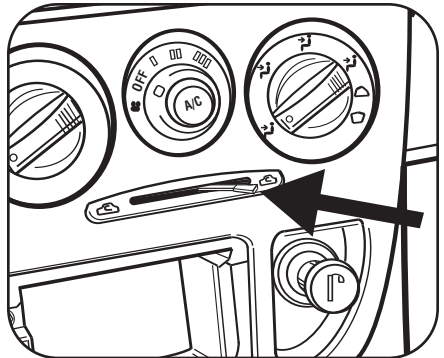
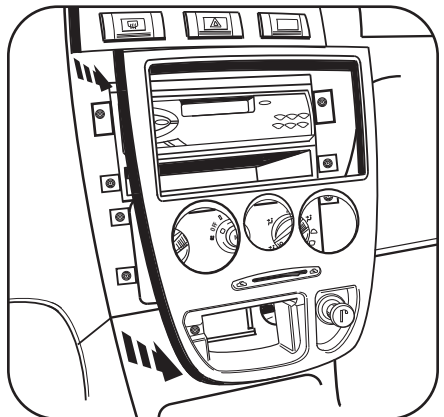
**A**

**B**

**C**

**SEPHIA 1995-1997**

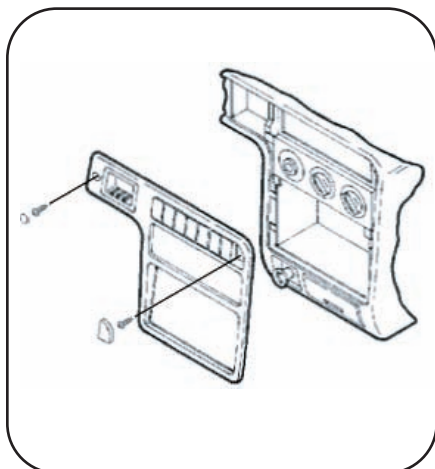
*\*Note: Refer also to the instructions included with the aftermarket radio.*

- 1** Disconnect the negative battery terminal to prevent an accidental short circuit.
- 2** Remove plastic screw cover to the left of the coin tray and remove the Phillips head screw from behind cover.
- 3** Remove switch blank to the far right of the switch panel and remove the Phillips head screw from behind switch blank.
- 4** Unclip and remove dash trim panel.
- 5** Remove (4) Phillips head screws securing the radio. Unplug and remove the radio.



*Continue to kit preparation.*

**SEPHIA 1998-2001**  
**SPECTRA 2000-2001**

*\*Note: Refer also to the instructions included with the aftermarket radio.*

- 1 Disconnect the negative battery terminal to prevent an accidental short circuit.
- 2 Remove (1) Phillips head screw from above instrument cluster.
- 3 Unclip and remove dash trim panel.
- 4 Remove (4) Phillips head screws securing the radio. Unplug and remove the radio.

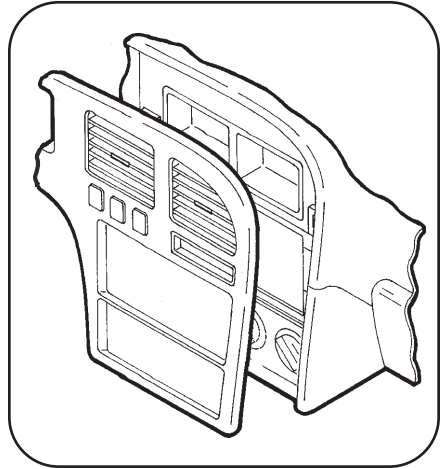

*Continue to kit preparation.*

**SPORTAGE 1995-1997**

*\*Note: Refer also to the instructions included with the aftermarket radio.*

- 1** Disconnect the negative battery terminal to prevent an accidental short circuit.
- 2** Remove ashtray and (2) Phillips head screws inside ashtray cavity.
- 3** Unclip and remove dash trim panel.
- 4** Remove (4) Phillips head screws securing the radio. Unplug and remove the radio.

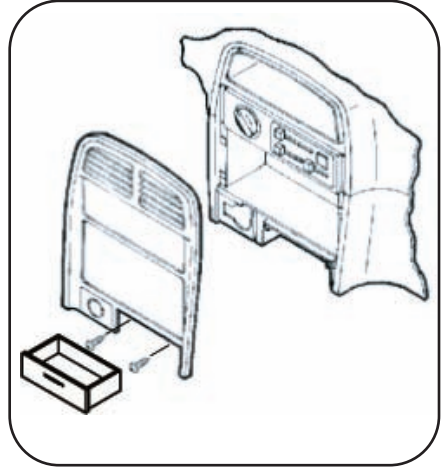

*Continue to kit preparation.*

**SPORTAGE 1998-2000**

*\*Note: Refer also to the instructions included with the aftermarket radio.*

- 1** Disconnect the negative battery terminal to prevent an accidental short circuit.
- 2** Unclip and remove dash trim panel.
- 3** Remove (4) Phillips head screws securing the radio. Unplug and remove the radio.

*Continue to kit preparation.*

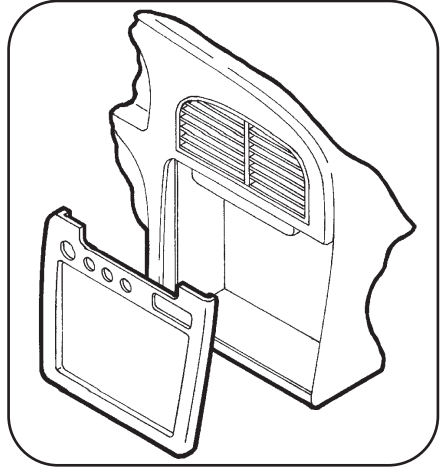

**SPORTAGE 2001-2003**

*\*Note: Refer also to the instructions included with the aftermarket radio.*

- 1 Disconnect the negative battery terminal to prevent an accidental short circuit.
- 2 Unclip and remove climate control/vent trim panel. (Figure A)
- 3 Remove screw covers from trim panel below steering column and remove screws from behind covers. Lower the trim panel (it is not necessary to remove the panel). (Figure B)
- 4 Remove (3) Phillips head screws from bottom of steering column housing and remove both upper and lower sections of housing.
- 5 Remove (1) Phillips head screw from outside left edge of dash and (2) Phillips head screws from near hood release. (Figure C)
- 6 Loosen nut behind hood release and remove lower left side dash trim. (Figure C)
- 7 Remove (4) Phillips head screws from instrument trim panel and remove panel. (Figure D)
- 8 Remove (4) Phillips head screws securing the radio. Unplug and remove the radio.

*Continue to kit assembly.*

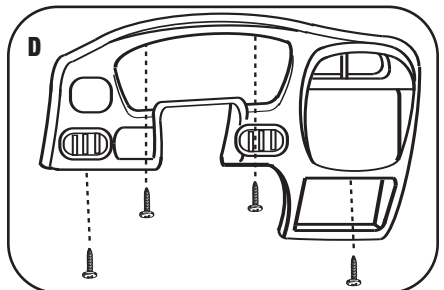
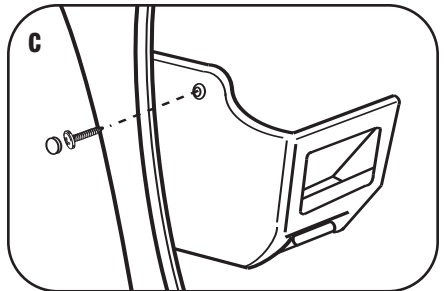
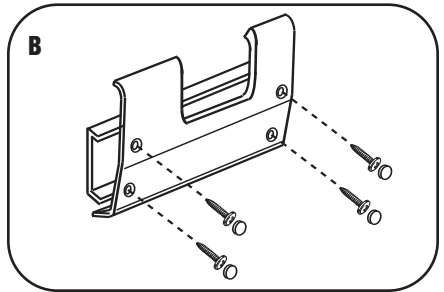
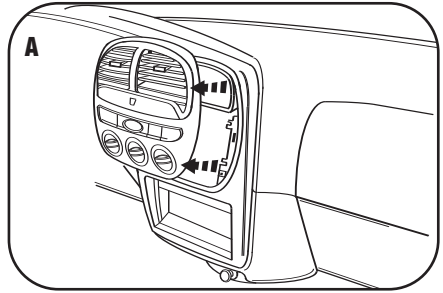



## KIT ASSEMBLY PREPARATION

*\*Note: Refer also to the instructions included with the aftermarket radio.*

### **RIO 2001**

### **SEPHIA 1995-1997**

Cut and remove mounting tabs "B" from Radio Housing #2. (The tabs can be identified by the letter stamped on the back of each tab.) (Figure A)

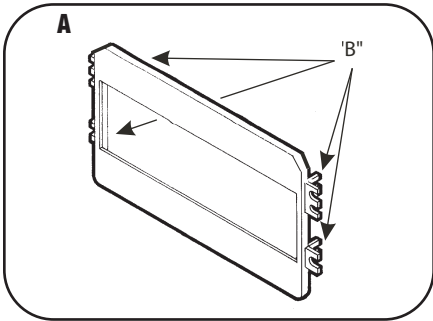

### **SEPHIA 1998-2001**

### **SPECTRA 2000-2001**

Cut and remove mounting tabs "B" from Radio Housing #1. (The tabs can be identified by the letter stamped on the back of each tab.) (Figure B)

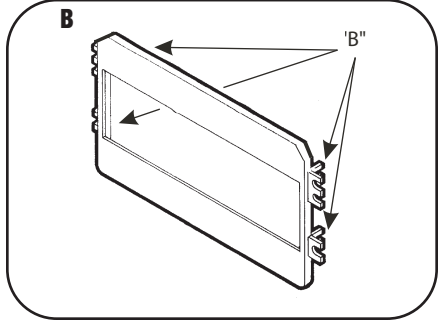

### **SPORTAGE 1995-1997**

Cut and remove mounting tabs "A" from Radio Housing #2 and the mounting brackets. (The tabs can be identified by the letter stamped on the back of each tab.) Locate the scored line on the back of the radio housing and break away the bottom portion of the housing as shown. (Figure C)

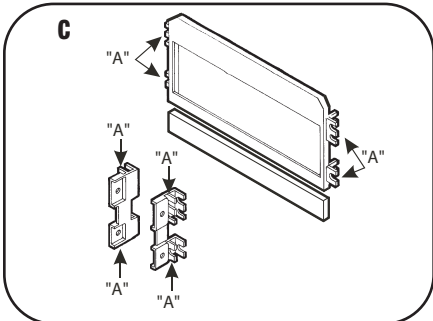

### **SPORTAGE 1998-2003**

Cut and remove mounting tabs "A" from Radio Housing #1. Cut and remove tabs "B" from the mounting brackets. (The tabs can be identified by the letter stamped on the back of each tab.) (Figure D)

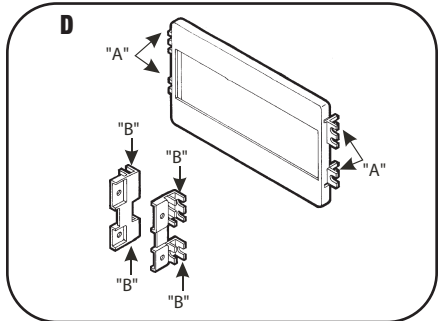

Continue to kit assembly.

## DIN MOUNT RADIO

*\*Note: Refer also to the instructions included with the aftermarket radio.*

**NOTE:** For Sportage 1995-97 and 1998-03 secure the Mounting Brackets to the Radio Housing with (4) Captive Studs and (4) Pal Nuts. (Figure A)

- 1 Slide the DIN cage into the radio housing and secure by bending the metal locking tabs outward. (Figure B)
- 2 Slide the radio into the DIN cage/housing assembly until it snaps into place. (Figure C)

**A**

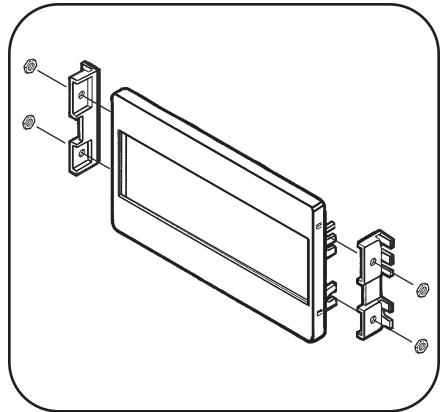

*Continue to final assembly.*

**B**

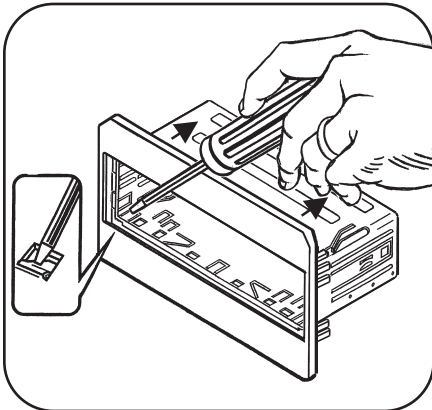

**C**

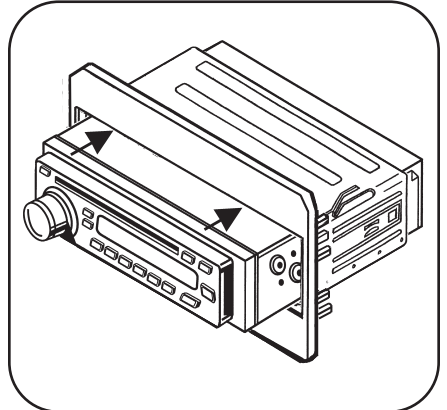

# FINAL ASSEMBLY

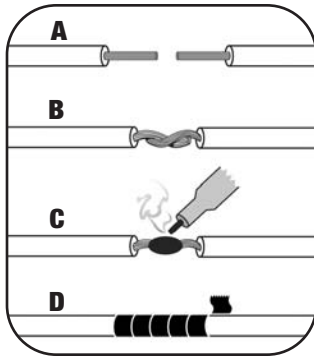

**(A) Strip wire ends back 1/2"**

**B) Twist ends together**

**C) Solder**

**D) Tape**

- 1 Locate the factory wiring harness in the dash. Metra recommends using the proper mating adapter and making connections as shown. (Isolate and individually tape off the ends of any unused wires to prevent electrical short circuit.)
- 2 Re-connect the negative battery terminal and test the unit for proper operation.
- 3 Reassemble radio and dash assemblies in reverse order of disassembly.

## FINAL WIRING CONNECTIONS

Make wiring connections using the EIA color code chart shown below and the instructions included with the head unit. Metra recommends making connections as shown below; Strip, Splice, Solder, Tape. Isolate and individually tape off ends of any unused wires to prevent electrical short circuit.

### METRA / EIA WIRING CODE

12V Ignition / Acc. . . . . Red	Right Front (+) . . . . . Gray
12V Batt / Memory . . . . . Yellow	Right Front (-) . . . . . Gray/ Black
Ground . . . . . Black*	Left Front (+) . . . . . White
Power Antenna . . . . . Blue	Left Front (-) . . . . . White / Black
Amp Turn-On . . . . . Blue / White	Right Rear (+) . . . . . Violet
Amp Ground . . . . . Black / White	Right Rear (-) . . . . . Violet / Black
Illumination . . . . . Orange	Left Rear (+) . . . . . Green
Dimmer . . . . . Orange / White	Left Rear (-) . . . . . Green / Black

**\*NOTE:** When a Black wire is not present, ground radio to vehicle chassis.

All colors may not be present on all leads due to manufacturer's specifications.

# 99-1003 INSTRUCTIONS



**1-800-221-0932**



**[www.metraonline.com](http://www.metraonline.com)**

Rev. 04/13/09 © COPYRIGHT 2004-2009 METRA ELECTRONICS CORPORATION INST99-1003