

Sunbeam

Fresh Start™

Juice extractor with whole fruit chute

Instruction Booklet

This book covers the use and care of the following juicers:

JE6400 – White

JE6400G – Lime Crush

JE6400R – Watermelon Ice

JE6400Y – Lemon Tang

JE6400M – Mango Tango

JE6400S – Satin

Please read these instructions carefully
and retain for future reference.



Contents

Safety Precautions for your Juicer	1
Features of your Fresh Start™ Juicer	2
Helpful hints for juicing	4
A guide to the benefits of juicing	5
Assembling your Fresh Start™ Juicer	7
Operating your Fresh Start™ Juicer	9
Juicing speed guide	10
Disassembling your Fresh Start™ Juicer	11
Care and Cleaning	12
Trouble shooting guide	13
Recipes	
Day starters	14
Juice remedies	15
Juice jolts	16
A good start for kids	17

Important instructions – retain for future use.

تأكد من تفهم احتياطات السلامة المذكورة اعلاه

請務必理解上述的安全預防措施。

Assurez-vous que les précautions ci-dessus relatives à la sécurité sont bien comprises

Versichern Sie sich daß die obenstehenden Sicherheitsmaßnahmen Verstanden werden

Βεβαιώνετε πως οι παραπάνω προφυλάξεις ασφαλείας γίνονται κατανοητές

Pastikan bahwa tindakan-tindakan keselamatan seperti di atas dimengerti anda

Accertatevi che le suddette norme di sicurezza siano comprese a dovere

上記の注意事項をよくお読みになり、安全を御確認ください

Уверете се дека погоре споменатите мерки на претпазливост се добро разбрани

Asegúrese de que las precauciones de seguridad precedentes sean bien comprendidas

کاری بکنید کہ احتیاط‌های بالا حتماً درک بشوند

ต้องแน่ใจว่า ข้อควรระวังเรื่องความปลอดภัยข้างต้น เป็นที่เข้าใจกันดี

Yukarda belirtilen güvenlik önlemlerinin anlaşılığundan emin olunuz

Xin kiểm chắc rằng những biện pháp làm an toàn kể trên được hiểu rõ

Sunbeam's Safety Precautions

SAFETY PRECAUTIONS FOR YOUR SUNBEAM JUICER.

- Do not put fingers or other objects into the feed chute whilst the juicer is in operation.
- Do not push fruit or vegetables into the feed chute with your fingers, always use the food pusher provided.
- If any fruit or vegetables become lodged in the feed chute, use the food pusher or turn off the juicer, remove the plug from the power outlet and disassemble to remove the lodged fruit or vegetables.
- Never operate without pulp container.
- Ensure the juicer is correctly and completely assembled before turning the appliance 'On'.
- Ensure the juicer cover is clamped securely and pulp container is in place before juicer is turned on. Do not unfasten the twin-locking handles while the juicer is in operation.
- Juicing blades are very sharp, handle juicing filter basket with care when removing, replacing and cleaning.
- Always operate the juicer on a flat, level surface.
- Do not operate for more than 30 seconds at a time when juicing heavy loads. None of the recipes in this manual are considered a heavy load.

Sunbeam are very safety conscious when designing and manufacturing consumer products, but it is essential that the product user also exercise care when using an electrical appliance. Listed below are precautions which are essential for the safe use of an electrical appliance:

- Read carefully and save all the instructions provided with an appliance.
- Always turn the power off at the power outlet before you insert or remove a plug. Remove by grasping the plug – do not pull on the cord.
- Turn the power off and remove the plug when the appliance is not in use and before cleaning.
- Do not use your appliance with an extension cord unless this cord has been checked and tested by a qualified technician or service person.
- Always use your appliance from a power outlet of the voltage (A.C. only) marked on the appliance.
- This appliance is not intended for use by young children or infirm persons unless they have been adequately supervised by a responsible adult to ensure that they can use the appliance safely.
- Young children should be supervised to ensure that they do not play with the appliance.
- Never leave an appliance unattended while in use.
- Do not use an appliance for any purpose other than its intended use.
- Do not place an appliance on or near a hot gas flame, electric element or on a heated oven. Do not place on top of any other appliance.
- Do not let the power cord of an appliance hang over the edge of a table or bench top or touch any hot surface.
- Do not operate any electrical appliance with a damaged cord or after the appliance has been damaged in any manner. If damage is suspected, return the appliance to the nearest Sunbeam Appointed Service Centre for examination, repair or adjustment.
- For additional protection, Sunbeam recommend the use of a residual current device (RCD) with a tripping current not exceeding 30mA in the electrical circuit supplying power to your appliances.
- Do not immerse the appliance in water or any other liquid unless recommended.

If you have any concerns regarding the performance and use of your appliance, please visit www.sunbeam.com.au or contact the Sunbeam Consumer Service Line. Ensure the above safety precautions are understood.

Features of your Sunbeam Fresh Start™ Juicer

Food pusher

Whole fruit & vegetable feed chute

The extra large 75mm diameter feed chute takes whole fruit and vegetables reducing the amount of preparation needed.

Patent pending feed chute lever

Ensures a controlled and safe juicing action. The lever suspends the fruit above the blade until you are ready to apply downward pressure with the food pusher and commence juicing.

Juicer cover

Juice collector / bowl

Twin-locking handles with safety braking system

4-second braking system provides essential safety. The blades will come to a complete stop, either when the juicing switch is turned 'Off' or the twin-locking levers are released.

Control switch with two speeds and off

Two speed control to optimise juicing results. Low speed for soft fruit, particularly those with a high water content including oranges and watermelon. High speed is ideal for hard and fibrous fruit and vegetables such as apples, ginger, celery and carrots.

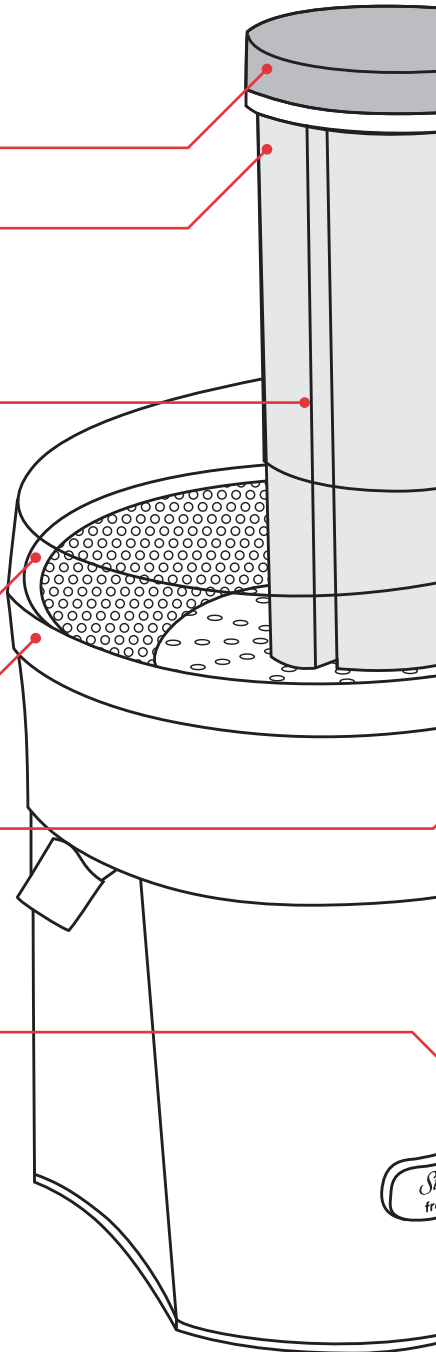

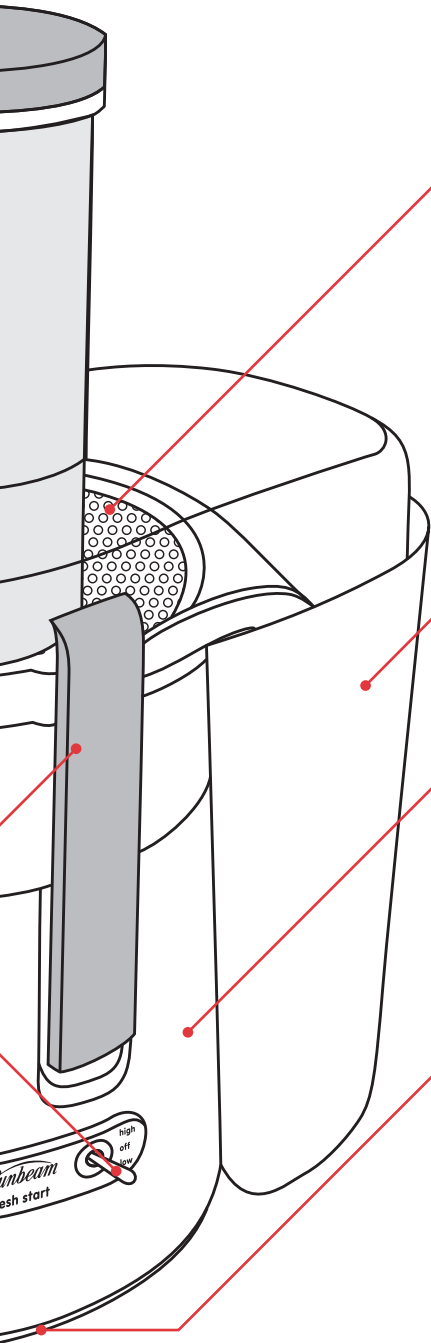

Stainless steel blade and filtering basket

The commercial quality stainless steel blade and filtering basket, designed to maximise extraction of juice from fruit and vegetables.

Extra large pulp container

Large 3 litre capacity pulp container is ideal for extracting large volumes of juice without stopping. Once full the pulp container can be easily removed without having to dismantle the juicer.

Powerful 850 watt motor

Powerfully built 850 watt motor with 5 year guarantee, extracts juice at slower speeds reducing oxygen and heat damage to juice – ensuring maximised juice extraction and less froth.

Cord wrap

Cord wraps away to keep bench top clean.

Non-slip feet

Heavy-duty non-slip feet ensure the juicer remains stable and prevents slipping on the bench top during use.

Juicing jug

1 litre juicing jug with froth separating lid ensuing on easy pour and a smooth tasting juice.

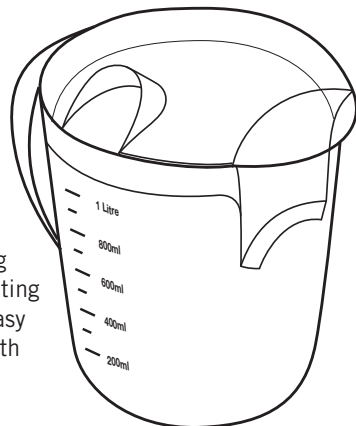

Helpful hints for juicing

Preparing fruit and vegetables

Wash all fruit and vegetables well before juicing. There is no need to peel vegetables that have a thin skin but a light scrub with a clean sponge will help rid of any dirt that may be stuck on or any waxy coatings.

Peel fruit and vegetables that have a thick skin such as melons, pineapple and citrus fruit.

Juice only the freshest of fruit and vegetables to get the most out them and the best flavours.

Cut large pieces of fruit, such as melons into large wedges.

Some seeds from citrus fruits can be bitter so you may want to remove some of the seeds if desired.

Remove seeds and stones from fruit such as mangoes, papaya and stone fruit. This will prevent the blade from getting damaged.

Juicing techniques

When juicing different fruit and vegetables it may help to juice in different combinations. For example, when juicing apples and oranges, juice the soft fruit (oranges) first, then follow with the hard fruit (apples) second. This will help you to achieve the maximum juice extraction from the fruit and vegetables.

When juicing fresh herbs such as mint or parsley, add the herbs in between the fruit and vegetables to get the most out of the herb or if only using a small quantity, add the herb at the same time as a piece of fruit and vegetable.

Bananas can be hard to juice but the taste goes a long way. When juicing a blend of fruit with bananas, add the banana as either the first or second piece of fruit. The nectar of the banana will sit inside the filtering basket and as the remaining fruits are added into the juice extractor they will release the banana nectar throughout the rest of the juice resulting in frothy flavoursome juice.

When juicing small fruit such as grapes or strawberries, add the fruit in handfuls rather than one at a time, this will maximise the amount of juice extracted.

Be aware that beetroot stains all other fruit and vegetables. If juicing several different juice combinations, juice the drink with the beetroot last, so as to not stain the other drinks.

A guide to the benefits of juicing

Fruit / Vegetable	Source of	Benefits	KJ per 100g
Apples	Carotenes, pectin, potassium, vitamin C and dietary fibre, energy giving carbohydrates.	May help in the treatment of constipation.	150kj/100g
Apricots	Beta-carotene, iron, vitamin C, dietary fibre.	High in natural sugars for energy.	280kj/100g
Banana	Potassium, carbohydrates, dietary fibre, vitamin B6, vitamin C.	Provides sustained energy.	225kj/100g
Beetroot	Folate, potassium, leafy tops are rich in beta carotene, calcium and iron.	The folate is excellent for healthy cells.	120kj/100g
Blueberries	Carotenoids, vitamin C.	Antibacterial.	200kj/100g
Capsicum	High in vitamin C, beta carotene.	1 red capsicum has enough vitamin C to meet the daily needs of 10 people.	135kj/100g
Carrots	Beta carotene, folate, dietary fibre.	May help with night vision.	100kj/100g
Celery	Only small amounts of vitamins and minerals.	Helps to clean mouth and teeth.	50kj/100g
Cherries	Very high in vitamin C, dietary fibre.	May help to stabilise the heartbeat and also keeps the skin healthy.	170kj/100g
Cucumber	Only small amounts of vitamins and minerals.	May help with flatulence.	30-50kj/100g
Fennel	Beta carotene, folate.	Fennel seeds are good for digestion.	50kj/100g
Ginger		Aids in digestion and is good for nausea and improves circulation.	
Grapefruit	Rich in vitamin C, fibre, bioflavenoids.	Pink grapefruit contains Lycopene which is an anti-cancer agent and may reduce the risk of prostate cancer.	110kj/100g
Honeydew Melon	Vitamin C, small amounts of carotenoids.	May stimulate the kidneys to help function better.	130kj/100g
Kiwi Fruit	Beta carotene, vitamin C, bioflavenoids, dietary fibre.	Helps in digestion and cleansing of the skin.	180kj/100g
Lemon	Bioflavenoids, limonene, pectin, vitamin C.	The pectin may help reduce blood cholesterol.	95kj/100g
Lime	Bioflavenoids, limonene, pectin, vitamin C.	The pectin may help reduce blood cholesterol.	90kj/100g
Mandarins	Vitamin C, beta carotene, folate,		165kj/100g

A guide to the benefits of juicing (continued)

Fruit / Vegetable	Source of	Benefits	KJ per 100g
Mango	Beta carotene, potassium, flavonoids and other antioxidants.	Easy to digest.	235kj/100g
Mint	Antispasmodic volatile oils, flavonoids, menthol.	Aids digestion.	
Oranges	High in vitamin C, fibre, beta carotene, flavonoids, thiamine, pectin, folate.	Excellent for healthy skin and helps the body's defences against bacterial infections.	100kj/100g
Papaya	Protective carotenoids, rich in vitamin C, fibre, rich in papain.	Helps digest proteins.	160kj/100g
Parsley	Vitamin C, iron.	Excellent for fresh breath.	
Pawpaw	Beta carotene, flavonoids, magnesium, rich in papain.	Helps digest proteins.	163kj/100g
Peaches	Good source of vitamin C, dietary fibre, beta carotene.	Easy to digest and works as a gentle laxative.	130kj/100g
Pears	Very good source of dietary fibre.	Provide a quick source of energy.	190kj/100g
Pineapple	Vitamin C, dietary fibre, beta carotene.	Helps to digest protein.	160kj/100g
Plums	Vitamin E, potassium, beta carotene, malic acid.	May help to retard the effects of wrinkling.	110-155kj/100g
Raspberries	High in dietary fibre, excellent source of vitamin C, some folate.	Helps in treating constipation.	110kj/100g
Rockmelons	Excellent source of vitamin C, beta carotene, carotenoids.	May help in the prevention of cancer and heart disease.	90kj/100g
Spinach	Zeaxanthin, vitamin C, beta carotene, folate, dietary fibre.	Helps in keeping eyes healthy in the elderly.	65kj/100g
Strawberries	Vitamin C, dietary fibre, some folate.	Helps to absorb iron better after eating meat.	80kj/100g
Tomatoes	Rich in lycopene, vitamin C, and small amounts of vitamin E, folate, dietary fibre.	May help reduce the risk of prostate cancer in men.	55kj/100g
Watercress	Vitamin C & E, folate, beta carotene, iron.	Thought to have cancer fighting properties.	72kj/100g
Watermelon	Carotenoids, beta carotene, vitamin C, dietary fibre.	May stimulate the kidneys to help function better.	95kj/100g

Assembling your Sunbeam Fresh Start™ Juicer

Before Use

After unpacking your Sunbeam Fresh Start™ Juicer, we recommend that you disassemble the unit before using for the first time. Wash all parts except the motor base in hot soapy water. Rinse and dry immediately.

Important: Always ensure your juicer is unplugged from the power outlet when not in use, during assembling or whilst removing parts.

1. Set the motor base on a dry, level surface.
For convenience when juicing, have the control switch facing you – figure 1.

Figure 1

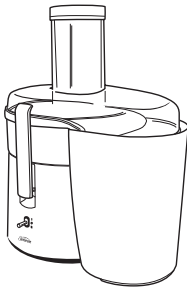

2. Place the juice collector / bowl onto the top of the motor base – figure 2.

Figure 2



3. Position the stainless steel blade and filtering basket onto the motor drive shaft and push down until firmly in place, the arrows indicate the correct alignment position of the basket – figure 3.

Figure 3

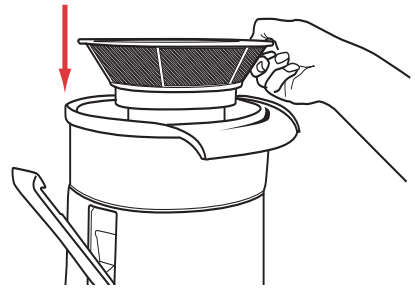

4. Place the juicer cover onto the juice collector / bowl, with the feed chute positioned over the stainless steel blade and filtering basket and push into position – figure 4.

Figure 4



Assembling your Sunbeam Fresh Start™ Juicer (continued)

5. Secure the juicer cover by raising the twin-locking handles and clip the tops to the juicer cover – figure 5a. Press firmly on the lower part of the twin-locking handles to lock into place – figure 5b.

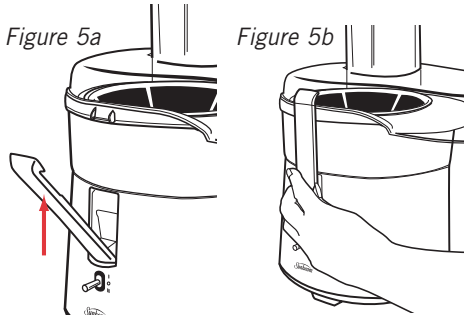

6. Slightly tilt the pulp container and slide into place under the juicer cover – figure 6.

Tip: To reduce cleaning we recommend that you line the pulp container with a plastic bag to collect the pulp.

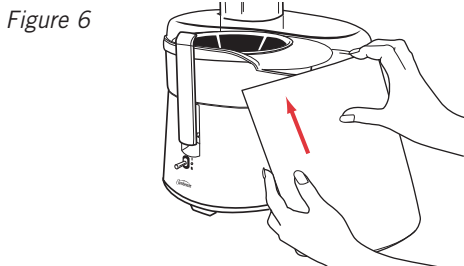

7. Take the food pusher, align the groove on the food pusher with the notch on the inside of the feed chute and slide the food pusher down into the feed chute – figure 7.

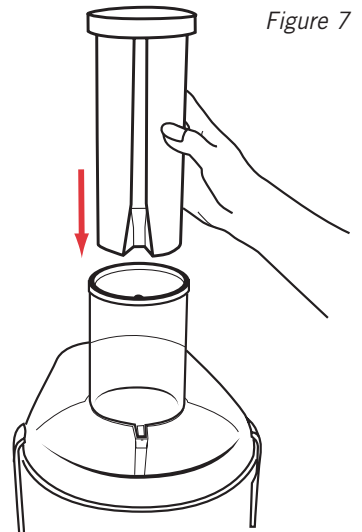

Operating your Sunbeam Fresh Start™ Juicer

Note: The Fresh Start™ juicer should be completely assembled before use, if this is not the case see 'Assembling your Sunbeam Fresh Start™ Juicer on page 7.

1. Ensure the control switch on the juicer is in the 'Off' position and insert the power cord into a 230-240V AC power outlet and turn the power 'On'.

2. Clean fruit and vegetables thoroughly, ready for juicing.

Note: The extra large feed chute allows whole fruit and vegetables to be juiced, however some fruit and vegetables may require other preparation before juicing, such as peeling and removing stones, see 'Juicing speed guide' on page 10 for our recommendations.

3. Ensure that the juicer has been assembled completely and correctly, making sure that the stainless steel blade and filtering basket revolves properly before placing fruit and vegetables in the juicer.

Note: The stainless steel blade and filtering basket should be cleaned thoroughly before each use, see 'Care and cleaning' on page 12.

4. Place a jug or glass under the juice spout.

5. Select 'Low' or 'High' speed with the control switch. To select 'Low' speed push the control switch up 'I'. To select 'High' speed push the control switch down 'II'.

For optimum juicing results 'Low' speed is used primarily for soft fruit and vegetables, particularly those with a high water content and 'High' speed is ideal for hard and fibrous fruit and vegetables. A list of fruit and vegetables commonly used for juicing and their recommended juicing speed are specified in the 'Juicing speed guide' on page 10.

Important: Do not operate for more than 30 seconds at a time when juicing heavy loads. None of the recipes in this manual are considered a heavy load.

6. With the juicer in operation, place the fruit and vegetables into the feed chute. Using the food pusher, guide the fruit and vegetables down the feed chute and onto the stainless steel blade.

Tip: For maximum juice extraction, guide the food pusher down the feed chute in a slow downward motion.

Important: Do not push fruit or vegetables into the feed chute with your fingers, always use the food pusher provided.

7. The juice from the fruit and vegetables will flow directly into the jug or glass and the pulp will be separated and collected in the pulp container.

Important: When juicing be aware of the level of pulp in the pulp collection container, because if the container is overfilled this can cause damage to the appliance and prevent the juicer from operating correctly.

8. When juicing is complete ensure that the juicer is switched 'Off' and unplugged from the power outlet.

Juicing speed guide

FRUIT / VEGETABLE TYPE	RECOMMENDED SPEED
Apples	High
Apricots – remove stone	Low
Banana – remove skin	Low
Beetroot	High
Blueberries	Low
Capsicum - remove seeds	Low
Carrots	High
Celery	High
Cherries – remove pips	Low
Cucumber	Low
Fennel	High
Ginger	High
Grapes - remove stems	High
Grapefruit – remove skin	Low
Honeydew melon – remove skin	Low
Kiwi fruit – remove skin	Low
Lemon – remove skin	Low
Lime – remove skin	Low
Mandarins – remove skin	Low
Mangoes – remove skin & seed	Low
Mint	High
Oranges – remove skin	Low
Papaya	High / Low
Parsley	High
Pawpaw	High / Low
Peaches – remove stone	Low
Pears	High / Low
Pineapple – remove skin	High
Plums – remove stone	Low
Raspberries	Low
Rockmelons – remove skin	Low
Spinach	High
Strawberries	Low
Tomatoes	Low
Watercress	High
Watermelon – remove skin	Low

Disassembling your Sunbeam Fresh Start™ Juicer

1. Turn the power 'Off' at the power outlet and unplug the cord.
2. Slightly tilt the pulp container and slide away from the juicer – figure 8.

Figure 8

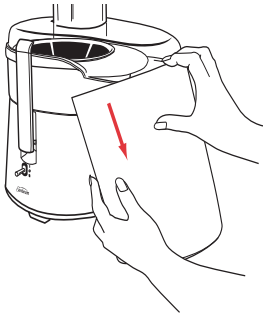

3. Place fingers under the bottom of the twin-locking handles and lift to release – figure 9.

Figure 9

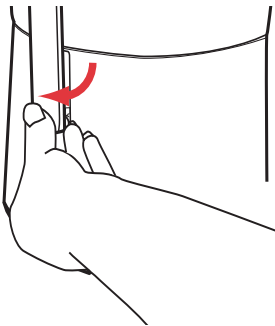

4. Lift the juicer cover from the juice collector/bowl – figure 10.

Figure 10

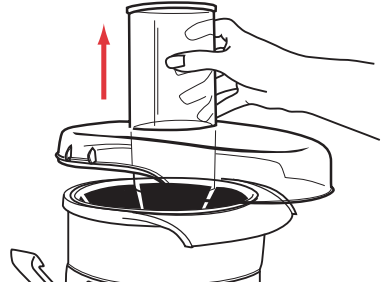

5. Place fingers under the rim of the stainless steel blade and filtering basket and lift out – figure 11.

Important: Juicing blades are very sharp, handle juicing filter basket with care when removing, replacing and cleaning.

Figure 11

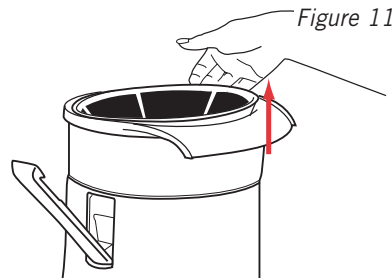

6. Lift the juice collector/bowl from the motor base – figure 12.

Figure 12

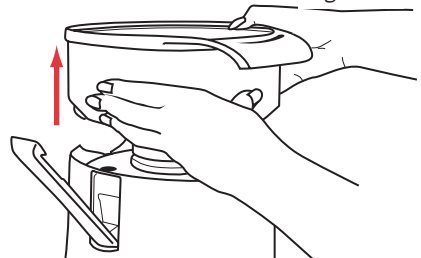

Care and cleaning

Note: Ensure that the juicer is unplugged from the power outlet prior to cleaning.

Dishwashing

All parts of the Sunbeam Fresh Start™ juicer, excluding the motor base, can be placed in the dishwasher for effortless cleaning after juicing.

Note: If using the dishwasher, due to high temperatures we recommend placing parts only on the top rack of your dishwasher. This will prevent any damage to the product due to heat.

Quick clean

For easy cleaning, ensure that immediately after use that the juicer is disassembled and that each removable part is rinsed under running water, removing any wet pulp and then allow to air dry.

Thorough cleaning

Disassemble the juicer and place all removable parts aside, see 'Disassembling your Fresh Start™ juicer on page 11. Rinse the juice collector, juicer cover, pulp container and food pusher under running water and wash with warm, soapy water. Rinse well.

Using the nylon cleaning brush supplied with the juicer, hold the stainless steel blade and filtering basket under running water and brush the outside of the basket first. Then with the basket still under running water, brush the inside of the basket in an anti-clockwise direction, removing the pulp. To ensure the stainless steel blade and filtering basket is free of all remaining pulp, hold it up to light and ensure that the holes in the filtering basket are not blocked.

Important: Juicing blades are very sharp, handle juicing filter basket with care when removing, replacing and cleaning. Use a soft, damp cloth to wipe the motor base clean.

To clean the motor base

Clean the motor base of the juicer using a damp soft sponge with mild detergent and wipe over the appliance.

Important: Never immerse the motor base in water or any other liquid.

Troubleshooting Guide

Problem	Possible cause	What to do
Juicer will not start when speed is selected.	The juicer hasn't been assembled correctly.	See 'Assembling your Fresh Start™ Juicer', on page 7.
The juicer motor appears to struggle during operation.	Pulp container is full.	Empty the pulp container.
	Pulp is caught in the juicer cover.	Stop juicing, remove the juicer cover and clean out pulp. See 'Disassembling your Fresh Start™ Juicer', and 'Care and Cleaning' sections. Try a slower juicing action – guide the food pusher down the feed chute in a slow downward motion.
	Stainless steel blade and filtering basket is blocked with excess pulp.	After extended juicing of fibrous fruit and vegetables the mesh on the filtering basket may need to be cleaned. Stop juicing, disassemble the juice extractor and clean the filtering basket. See 'Disassembling your Fresh Start™ Juicer', and 'Care and Cleaning' sections.
	The selected juicing speed is incorrect.	See 'Juicing speed guide' on page 10.
You notice less juice coming out of the juice spout.	Large amounts of highly fibrous fruit and vegetables have caused excess pulp to build up in the filtering basket.	Stop juicing, disassemble the juice extractor and clean the filtering basket. See 'Disassembling your Fresh Start™ Juicer' and 'Care and Cleaning' sections.

Recipes

DAY STARTERS

For all recipes in this section, process all ingredients listed in the recipe through the juicer, stir and serve immediately.

All recipes make approximately 2 small serves.

Zinger

Pineapple	¼ small, peeled
Green apples	2
Celery	1 stalk
Mint	1 sprig
Lemon	¼ small, peeled

Flying High

Carrot	3
Green apples	2
Beetroot	1 small

Distant Melons

Watermelon	1 wedge, 200g piece
Honeydew	¼, peeled
Rockmelon	¼, peeled

Orange Madness

Pawpaw removed	½ large, peeled, seeds removed
Rockmelon	¼, peeled, seeds removed
Lime	¼, peeled
Grapes	½ cup

Morning Calmer

Mango	1, seed removed
Oranges	2, peeled
Blood plums	4, seeds removed

Pick Up The Pace

Carrot	4
Green apple	1
Parsley	1 handful
Kiwi fruit	1, peeled

Recipes (continued)

JUICE REMEDIES

For all recipes in this section, process all ingredients listed in the recipe through the juicer, stir and serve immediately.

All recipes make approximately 2 small serves.

Immune Booster

Green apples	3
Celery	3 stalks
Ginger	2cm piece

See the light

Green apples	2
Carrot	2
Ginger	2cm piece

Fuzzy Thoughts

Carrot	2
Celery	2 stalks
Green apples	1
Kiwi Fruit	1, peeled
Ginger	2cm piece

Jack's Juice

Tomatoes	3
Celery	1 stalk
Carrot	1

Body Cleanser

Carrot	3
Celery	1
Pear	1
Beetroot	1 small

Power Purifier

Carrot	3
Beetroot	1 small
Red capsicum	½, seeds removed
Spinach	2 large leaves

Classic Karma

Carrot	3
Green apples	2
Celery	2 stalks
Parsley	1 handful

Recipes (continued)

JUICE JOLTS

For all recipes in this section, process all ingredients listed in the recipe through the juicer, stir and serve immediately.

All recipes make approximately 2 small serves.

Tropical Memories

Pineapple	¼ small, peeled
Strawberries	2 large
Kiwi Fruit	1, peeled
Watermelon	1 wedge, 200g piece

Cafe Cruiser

Pineapple	¼ small, peeled
Watermelon	1 wedge, 200g piece
Orange	1 small, peeled
Pear	½

Magenta Goddess

Beetroot	1 small
Carrot	2
Green apples	2
Pineapple	¼ small, peeled

Watery Wonderland

Watermelon	1 wedge, 300g piece
Pineapple	¼ small, peeled
Mint	1 sprig

Juice Rush

Rockmelon	¼, peeled
Carrot	2
Watermelon	1 wedge, 300g piece
Lime	half, peeled

Tropical Treasure

Mango	½
Rockmelon	½, peeled, seeds removed
Blueberries	½ cup
Passionfruit	flesh scooped into glass

That girl

Watermelon removed	2 wedges, 500g, skin removed
Lemon	¼, skin removed

Recipes (continued)

A GOOD START FOR KIDS

For all recipes in this section, process all ingredients listed in the recipe through the juicer, stir and serve immediately.

All recipes make approximately 2 small serves.

Goody Gumdrops

Orange	1, peeled
Pineapple	¼ small, peeled
Strawberries	2 large
Kiwi Fruit	1, peeled

Frothy Fantasy

Strawberries	4
Green apple	1
Banana	1, peeled
Grapes	1 cup

Berry Cherry

Strawberries	250g
Cherries	1 cup, stoned

Juicy Juice

Raspberries	125g, frozen, thawed
Pear	1 small
Water	⅓ cup

Drink Your Veges!

Carrot	2
Green apple	1
Celery	1 stalk

Kid Cold Crusher

Orange	2
Pineapple	¼ small, peeled

Ally In Wonderland

Orange	2
Strawberries	8
Passionfruit	1, pulp scooped into glass

Notes

Notes

'Sunbeam', is a registered trademark of Sunbeam Corporation. 'Fresh Start™' is a trademark of Sunbeam Corporation.

Made in China. Due to minor changes in design or otherwise, the product may differ from the one shown in this leaflet. Backed by Sunbeam's 12 Month Replacement Guarantee and National Service Network.

© Copyright. SUNBEAM CORPORATION LIMITED 2006.

(INCORPORATED IN N.S.W.) A.C.N. 000 006 771

Sunbeam Corporation is a division of GUD Holdings Ltd.

For more information or advice on this or any other Sunbeam appliance, visit www.sunbeam.com.au or contact the Sunbeam Consumer Service Line.

Australia 1800 025 059

New Zealand 0800 786 232.

Sunbeam

Consumer Hotline

Australia

1800 025 059

New Zealand

0800 786 232

www.sunbeam.com.au

 is a registered Trademark of Sunbeam Corporation Limited. ACN 000 006 771.

© Sunbeam Corporation Limited 2006.