

AquaMAX™

AX 650

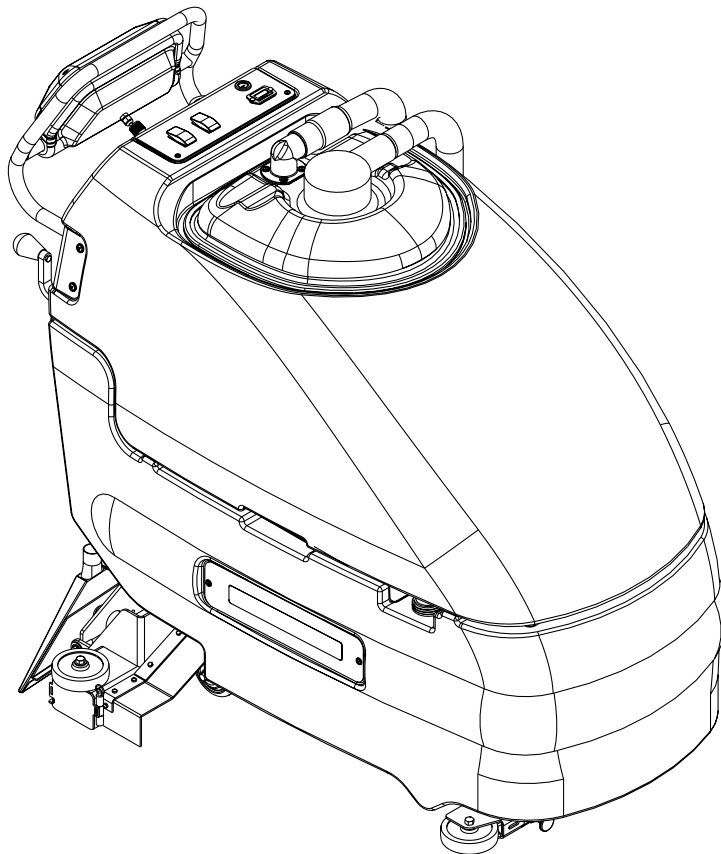

Instructions For Use
Advance MODEL 56212000
Nilfisk MODEL 56212260



**Nilfisk
Advance**
setting standards

English

3/04 revised 10/06 Form Number 56041551



2 ENGLISH

TABLE OF CONTENTS

	Page
Introduction	3
Parts and Service	3
Nameplate	3
Uncrating the Machine	3
Important Safety Instructions	4
Consignes de Securite Importantes	5
Know Your Machine	6-7
Functional Description of Controls	8
Preparing the Machine for Use	
Installing the Batteries	9
Filling the Solution Tank	9
Pre-Spraying the Carpet	9
Plan for Cleaning	9
Operating the Machine	10
Using Attachments	10
After Using the Machine	11
Maintenance Schedule	11
Maintenance	
Pick-Up Tool Maintenance	12
Spray Nozzle Maintenance	12
Lubricating the Machine	12
Cleaning the Vacuum Motor Filters	12
Adjusting the Brush Height	12
Power Brush Maintenance	12
Removing the Brush	12
Charging the Batteries	13
Checking the Battery Water Level	13
Battery Maintenance	13
Battery Testing	13
Troubleshooting	
Control Circuit Circuit Breaker	14
Wheel Drive Circuit Breaker	14
Brush Drive Circuit Breaker	14
Vacuum Motor Circuit Breaker	14
Technical Specifications	14

INTRODUCTION

This manual will help you get the most from your Nilfisk-Advance AquaMAX™ / AX 650. Read it thoroughly before operating the machine.

Note: Bold numbers in parentheses indicate an item illustrated on pages 6-7.

This product is intended for commercial use only.

PARTS AND SERVICE

Repairs, when required, should be performed by your Authorized Nilfisk-Advance Service Center, who employs factory trained service personnel, and maintains an inventory of Nilfisk-Advance original replacement parts and accessories.

Call the NILFISK-ADVANCE DEALER named below for repair parts or service. Please specify the Model and Serial Number when discussing your machine.

(Dealer, affix service sticker here.)

NAME PLATE

The Model Number and Serial Number of your machine are shown on the Nameplate on the machine. This information is needed when ordering repair parts for the machine. Use the space below to note the Model Number and Serial Number of your machine for future reference.

MODEL NUMBER _____

SERIAL NUMBER _____

UNCRATE THE MACHINE

When the machine is delivered, carefully inspect the shipping carton and the machine for damage. If damage is evident, save the shipping carton so that it can be inspected. Contact the Nilfisk-Advance Customer Service Department immediately to file a freight damage claim.

4 ENGLISH

IMPORTANT SAFETY INSTRUCTIONS

This machine is only suitable for commercial use, for example in hotels, schools, hospitals, factories, shops and offices other than normal residential housekeeping purposes.

When using an electrical appliance, basic precautions should always be followed, including the following:



Read all instructions before using.

WARNING!

To reduce risk of fire, electric shock, or injury:

- This machine should only be used by properly trained and authorized persons.
- Keep sparks, flame and smoking materials away from batteries. Explosive gases are vented during normal operation.
- Charging the batteries produces highly explosive hydrogen gas. Charge batteries only in well-ventilated areas, away from open flame. Do not smoke while charging the batteries.
- Remove all jewelry when working near electrical components.
- Turn the key switch off (O) and disconnect the batteries before servicing electrical components.
- Never work under a machine without safety blocks or stands to support the machine.
- Do not dispense flammable cleaning agents, operate the machine on or near these agents, or operate in areas where flammable liquids exist.
- Do not clean this machine with a pressure washer.
- Do not operate this machine on ramps or inclines of more than a 2 percent gradient.
- Only use the brushes provided with the appliance or those specified in the instruction manual. The use of other brushes may impair safety.

CAUTION!

- This machine is not approved for use on public paths or roads.
- This machine is not suitable for picking up hazardous dust.
- When operating this machine, ensure that third parties, particularly children, are not endangered.
- Before performing any service function, carefully read all instructions pertaining to that function.
- Do not leave the machine unattended without first turning the key switch off (O), removing the key and securing the machine.
- Turn the key switch off (O) and remove the key, before changing the brushes, and before opening any access panels.
- Take precautions to prevent hair, jewelry, or loose clothing from becoming caught in moving parts.
- Use caution when moving this machine in below freezing temperature conditions. Any water in the solution or recovery tanks or in the hose lines could freeze.
- The batteries must be removed from the machine before the machine is scrapped. The disposal of the batteries should be safely done in accordance with your local environmental regulations.
- Do not use on surfaces having a gradient exceeding that marked on the machine.
- All doors and covers are to be positioned as indicated in the instruction manual before using the machine.

SAVE THESE INSTRUCTIONS

CONSIGNES DE SECURITE IMPORTANTES

Cette machine est destinée à un usage commercial et peut, entre autres, être utilisée dans les hôtels, écoles, hôpitaux, usines, magasins et bureaux. Elle n'a donc pas été conçue pour l'entretien ménager.

Lorsque vous utilisez un appareil électrique, il y a certaines règles de base que vous devez toujours observer, dont celle énoncée ci-après.



Lire toutes les instructions avant d'utiliser l'appareil.

ATTENTION!

Afin de réduire les risques d'incendie, de décharge électrique ou de blessure :

- Cette machine ne pourra être utilisée que par du personnel parfaitement entraîné et dûment autorisé.
- Eloignez les batteries de toutes flammes, étincelles ou substance fumigène. Les gaz explosifs sont ventilés pendant le fonctionnement normal.
- De plus, du gaz hydrogène explosif s'échappe des batteries lorsqu'elles sont en charge. Ne procédez au chargement des batteries que dans une zone bien ventilée, loin de toute flamme. Ne fumez pas à proximité des batteries lorsqu'elles sont en charge.
- Otez tous vos bijoux lorsque vous travaillez à proximité de composants électriques.
- Positionnez la clé de contact sur off (O) et déconnectez les batteries avant de procéder à l'entretien des composants électriques.
- Ne travaillez jamais sous une machine sans y avoir placé, au préalable, des blocs de sécurité ou des étais destinés à soutenir la machine.
- Ne déversez pas d'agents nettoyants inflammables, ne faites pas fonctionner la machine à proximité de ces agents ou d'autres liquides inflammables.
- Ne nettoyez pas cette machine avec un nettoyeur à pression.
- Ne faites pas fonctionner la machine sur des rampes ou pentes de plus de 2 pour-cent.
- Utilisez uniquement les brosses fournies avec l'appareil ou celles spécifiées dans le manuel d'instructions. L'utilisation d'autres brosses peut mettre la sécurité en péril.

PRUDENCE!

- Cette machine n'est pas conçue pour une utilisation sur les chemins ou voies publics.
- Cette machine n'est pas conçue pour le ramassage des poussières dangereuses.
- Lors de l'utilisation de cette machine, assurez-vous que des tiers, et notamment des enfants, ne courent pas le moindre risque.
- Avant de procéder à toute opération d'entretien, veuillez lire attentivement toutes les instructions qui s'y rapportent.
- Ne laissez pas la machine sans surveillance sans avoir, au préalable, coupé le contact, enlevé la clé de contact (O) et tiré le frein à main.
- Positionnez la clé de contact sur off (O) avant de remplacer les brosses ou d'ouvrir tout panneau d'accès.
- Prenez toutes les mesures nécessaires pour éviter que les cheveux, les bijoux ou les vêtements amples ne soient entraînés dans les parties mobiles de la machine.
- Faites attention lorsque vous déplacez cette machine dans un endroit où la température peut descendre sous 0°. Car l'eau contenue dans la solution, dans les réservoirs de récupération ou dans les conduites risquerait de geler.
- Prenez soin d'enlever les batteries de la machine avant de mettre cette dernière au rebut. Pour ce qui est de l'élimination des batteries, conformez-vous aux réglementations locales en matière d'environnement.
- N'utilisez pas sur des surfaces dont la pente dépasse celle mentionnée sur la machine.
- Toutes les portes et couvercles doivent être dans la position mentionnée dans le manuel d'instruction avant de mettre la machine en service.

CONSERVEZ SOIGNEUSEMENT CES INSTRUCTIONS

6 ENGLISH

KNOW YOUR MACHINE

As you read this manual, you will occasionally run across a bold number in parentheses - example: (2). These numbers refer to an item on this page. Refer back to this page whenever necessary to pinpoint the location of an item mentioned in the text.

- | | | | |
|----|--------------------------|----|---------------------------------------|
| 1 | Upper (recovery) Tank | 16 | Battery Charger Connector |
| 2 | Recovery Tank Dome Lid | 17 | Recovery Tank Drain Hose |
| 3 | Battery Fuel Gauge | 18 | Pick-Up Tool |
| 4 | Master Key Switch | 19 | Brush Height Adjustment Knob |
| 5 | Pump Switch | 20 | Brush Deck |
| 6 | Vacuum Switch | 21 | Solution Drain Hose / Level Indicator |
| 7 | Hour Meter | 22 | Solution Fill Cap |
| 8 | Brush Pressure Indicator | 23 | Vacuum Hose |
| 9 | Speed Control Knob | 24 | Recovery Hose |
| 10 | Operator Control Handle | 25 | Nozzle Selector Knob |
| 11 | Drive Paddle | 26 | Stabilizer Caster |
| 12 | Brush Deck Lift Lever | 27 | Rear Caster |
| 13 | Upper Tank Latch | | |
| 14 | Accessory Port | | |
| 15 | Circuit Breakers | | |
| | 6 Amp-Control Circuit | | |
| | 40 Amp-Vac Motors | | |
| | 20 Amp-Brush Motor | | |
| | 20 Amp-Drive Motor | | |

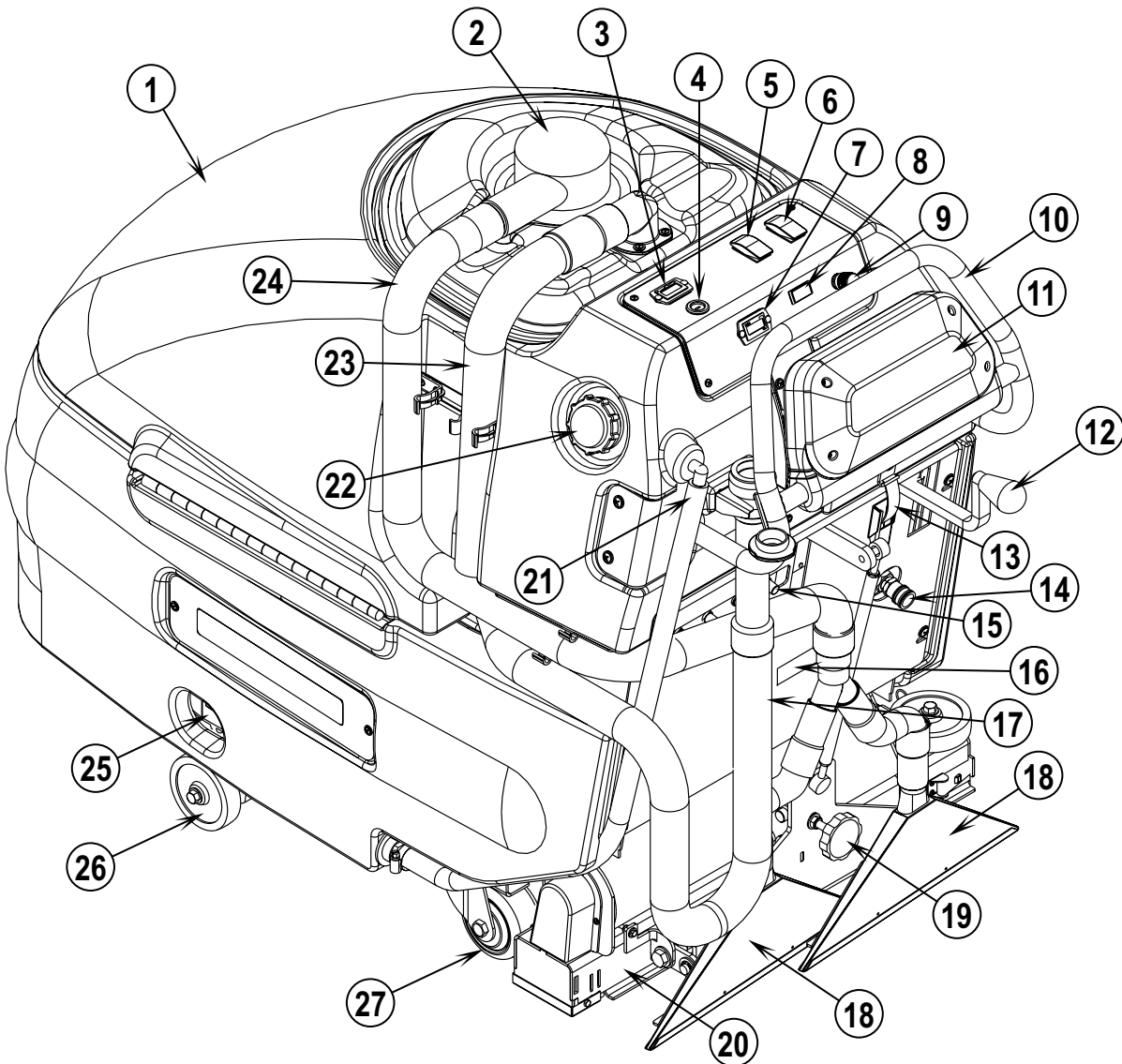

- 28 Lower (solution) Tank Flush-Out Cap
- 29 Brush Access Door
- 30 Brush Access Door Latch
- 31 Deck Release Knob
- 32 Vac Motor Filters
- 33 Automatic Float Shut-Off
- 34 Waste Water Bladder
- 35 Roller Bumper
- 36 InLine Pump Filter
- 37 Lower (solution) Tank
- 38 Roller Bumper Release Knob

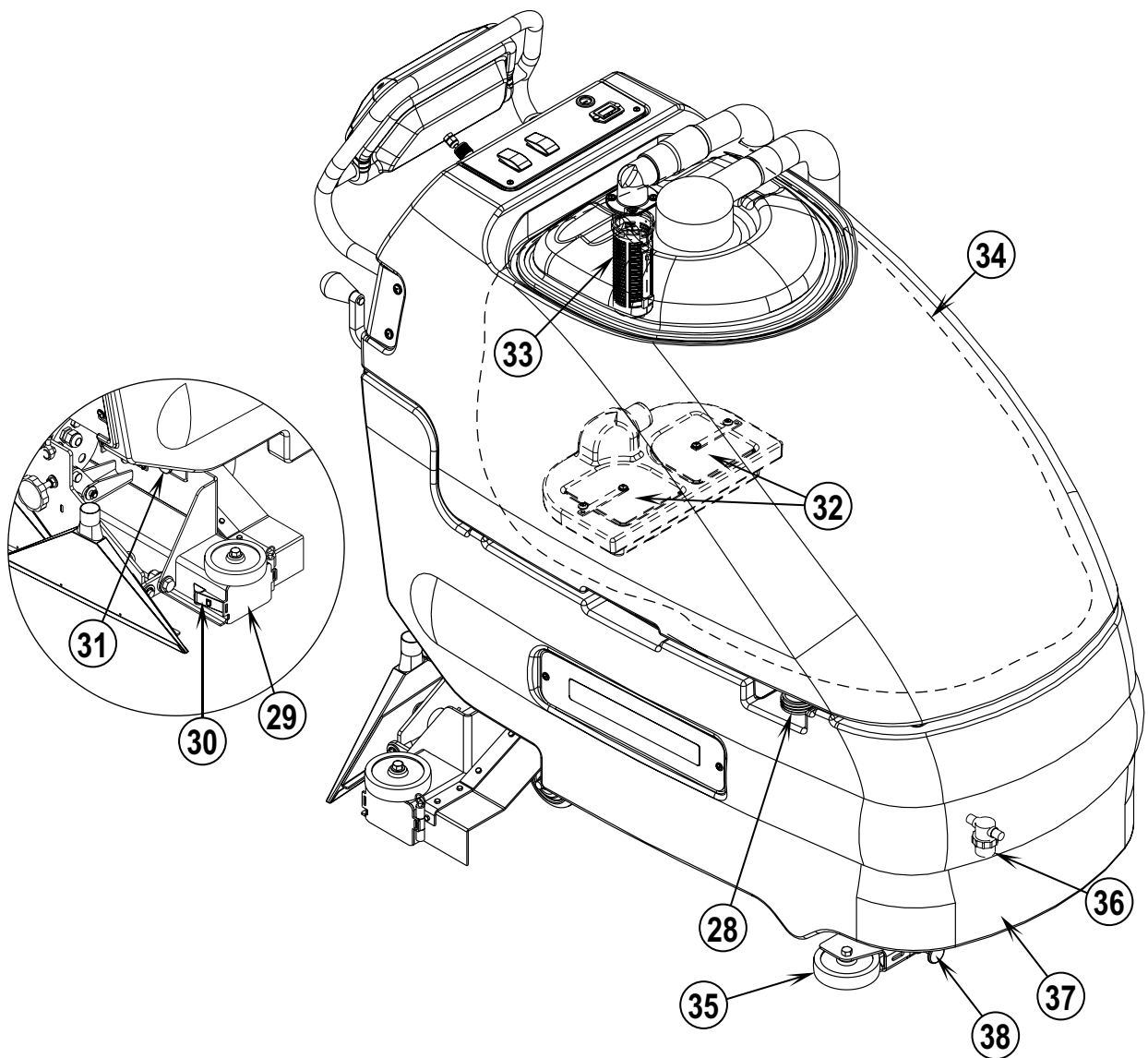

FUNCTIONAL DESCRIPTION OF CONTROLS:

Upper (recovery) Tank (1) - Waste water recovered from carpet is deposited here inside of a bladder (34). Area outside of waste water bladder (34) is utilized for extra clean solution capacity. The batteries and Vac Motor Filters (32) can be accessed by opening this tank to the side.

Recovery Tank Dome Lid (2) - Point of entry for waste water into bladder. Also houses Automatic Float Shut-Off (33) which shuts off vacuum port to vac motors when bladder is full. Remove this lid to rinse out the waste water bladder or to fill the solution tank.

Battery Fuel Gauge (3) - Shows current state of charge of batteries. A double-flashing light indicates low batteries, charge immediately. NOTE: When the battery fuel gauge shows double-flashing lights, all systems shut down except the wheel drive system.

Master Key Switch (4) - Main power switch.

Pump Switch (5) - This button is used to select the mode of operation for the solution system. There are 3 modes of operation for this system. The modes are AUTO / OFF / ON. Following is a description of each mode.

AUTO MODE: In this mode the solution flow will be turned ON whenever the brush is lowered and the machine is moving forward. The solution flow will be turned off when the machine is not moving, moving in reverse or the brush is raised.

OFF MODE: In this mode the solution flow is turned off.

ON MODE: This mode is for accessory use. The pump is ON at all times as long as the Master Key Switch (4) is ON.

Vacuum Switch (6) - This button is used to select the mode of operation for the vacuum system. There are 3 modes of operation for this system. These modes are AUTO / OFF / ON. Following is a description of each mode.

AUTO MODE: In this mode the vacuum will be turned ON whenever the brush is lowered and the Master Key Switch (4) is ON. While in this mode the vacuum will remain on for 10 seconds after the brush is raised.

OFF MODE: In this mode the vacuum is off.

ON MODE: This mode is for accessory use. The vacuum is ON at all times as long as the Master Key Switch (4) is ON.

Hourmeter (7) - Displays number of hours machine has been used. NOTE: The hourmeter only runs when the vac motors are running.

Brush Pressure Indicator (8) - This meter should be reading 8-15 amps (green zone), readings outside this range indicate the need for brush height adjustment.

Speed Control Knob (9) - Turn this knob clockwise to increase maximum speed range and counter-clockwise to decrease maximum speed range.

Operator Control Handle (10) - Operator holds onto this handle to maneuver the machine.

Drive Paddle (11) - The operator can make the machine go forward by pushing forward on it, or reverse by pulling backward on it. The speed is variable depending on how far forward or backward the paddle is moved. The brush and pump will operate when the brush deck is in the "DOWN" position and the drive paddle is engaged in either direction, both will stop 1 second after the drive paddle is released. NOTE: The pump does not run when the drive paddle is in the reverse position.

Brush Deck Lift Lever (12) - This lever is used to raise or lower the brush deck. Both pump and vacuum turn ON when the brush deck is lowered and turn OFF when it is raised if their switches are in the AUTO position. NOTE: Machine must be moving forward to activate pump, forward or reverse to activate brush.

Vacuum system shuts off 10 seconds after raising the brush deck.

Upper Tank Latch (13) - This latch is used to secure the Upper Tank (1) to the machine to prevent the tank from opening while operating the machine since the Operator Control Handle (10) is mounted to the upper tank.

Accessory Port (14) - This is used to connect external accessories.

Circuit Breakers (15)

6 Amp-Control Circuit - Provides overload protection. If it trips, it will pop out. To reset, wait one minute and press the button back in. If any breaker trips repeatedly, have the machine serviced.

40 Amp-Vac Motors - Provides overload protection to machine's vacuum motors. If it trips, it will pop out. To reset, wait one minute and press the button back in. If any breaker trips repeatedly, have the machine serviced.

20 Amp-Brush Motor - Provides overload protection to machine's brush motor. If it trips, it will pop out. To reset, wait one minute and press the button back in. If any breaker trips repeatedly, have the machine serviced.

20 Amp-Drive Motor - Provides overload protection to machine's wheel drive motor. If it trips, it will pop out. To reset, wait one minute and press the button back in. If any breaker trips repeatedly, have the machine serviced.

Battery Charger Connector (16) - Plug battery charger into this port to charge batteries.

Recovery Tank Drain Hose (17) - Used to empty the recovery tank. NOTE: Hold the end of the hose above the water level in the tank to avoid sudden, uncontrolled flow of waste water when removing plug.

Pick-Up Tool (18) - Removes excess solution from carpet after scrubbing.

Brush Height Adjustment Knob (19) - Used to adjust the height of the brush deck. Turn clockwise to raise the brush deck and counter-clockwise to lower the brush deck. NOTE: Use this adjustment knob in conjunction with the Brush Pressure Indicator (8).

Brush Deck (20) - Contains brush drive motor and brush.

Solution Drain Hose/Level Indicator (21) - Used to empty the solution tank and show current level of solution in tank, graduations are marked on the side of the machine next to the hose.

Solution Fill Cap (22) - The solution tank can be filled at this location or through the front opening at the top of the Upper Tank after removing the Recovery Tank Dome Lid.

Vacuum Hose (23) - This hose connects to the vac motor assembly in order to create a vacuum inside the waste water bladder.

Recovery Hose (24) - This hose connects between the Pick-Up Tools (18) and the Recovery Tank Dome Lid (2) to bring waste water into the bladder.

Nozzle Selector Knob (25) - Use this knob to select either Maintenance Mode or Restoration Mode. NOTE: The Speed Control Knob (9) has two corresponding settings.

Maintenance Mode: Lower solution flow, higher travel speed. Recommended for frequent surface cleaning.

Restoration Mode: Higher solution flow, lower travel speed. Recommended for less frequent deep cleaning.

Stabilizer Caster (26) - This caster provides stability to the unit when opening the Upper (recovery) Tank (1).

Rear Caster (27) - These two casters along with the main drive wheel bear the weight of the machine and allow easy maneuvering around corners.

Lower (solution) Tank Flush-Out Cap (28) - This cap allows access to the Lower (solution) Tank for the purpose of flushing with clean water.

Brush Access Door (29) - The power brush can be removed or installed via this door.

Brush Access Door Latch (30) - Unsnap this latch to allow access to the power brush.

Deck Release Knob (31) - Pull this knob out and slide Brush Deck out to the right until it latches in place. This allows cleaning under shelves, railings, etc.

Vac Motor Filters (32) - Intake filters for vacuum motor assembly. Refer to the maintenance chart for maintenance intervals.

Automatic Float Shut-Off (33) - The float shut-off blocks the vacuum port when the Waste Water Bladder (34) is full. You can tell when the float closes by the sudden change in sound of the vacuum motors. When the float closes, the recovery tank must be emptied. The machine will not pickup water with the float closed.

Waste Water Bladder (34) - Contains waste water as it is recovered from carpet. Total capacity of 30 gallons (113.5 Liters).

Roller Bumper (35) - This is a 3 position slide-out bumper to aid in machine maneuvering along walls.

InLine Pump Filter (36) - This filter removes debris from the solution prior to flowing through the pump. Drain solution prior to cleaning this filter.

Lower (solution) Tank (37) - This tank in combination with the upper tank brings total solution capacity to 40 gallons (151.4 Liters).

Roller Bumper Release Knob (38) - This knob allows you to slide the roller bumper out or in to limit how close the machine travels to the wall.

INSTALLING THE BATTERIES

⚠ WARNING!

Use extreme caution when working with batteries. Sulfuric acid in batteries can cause severe injury if allowed to contact the skin or eyes. Explosive hydrogen gas is vented from the batteries through openings in the battery caps. This gas can be ignited by any electrical arc, spark or flame.

When Servicing Batteries...

- * Remove all jewelry
- * Do not smoke
- * Wear safety glasses, rubber gloves and a rubber apron
- * Work in a well-ventilated area
- * Do not allow tools to touch more than one battery terminal at a time

⚠ CAUTION!

Electrical components in this machine can be severely damaged if the batteries are not installed and connected properly. Batteries should be installed by Nilfisk-Advance, a qualified electrician, or the battery manufacturer.

- 1 Remove the batteries from their shipping crate and carefully inspect them for cracks or other damage. If damage is evident, contact the carrier that delivered them or the battery manufacturer to file a damage claim.
- 2 Turn the Master Key Switch (4) OFF and remove the key.
- 3 Open the Upper (recovery) Tank (1). Remove the battery cables from inside the battery compartment.
- 4 Your machine comes from the factory with enough battery cables to install six 6 volt batteries. Carefully lift the batteries into the battery compartment and arrange them exactly as shown. Secure the batteries as close to the back of the machine as possible.
- 5 The terminals on the battery cables are marked "+" for positive and "-" for negative. Install the battery cables as shown, with the terminals marked "+" on the positive battery terminals and the terminals marked "-" on the negative terminals. Position the cables so the battery caps can be easily removed for battery service.
- 6 Carefully tighten the nut in each battery terminal until the terminal will not turn on the battery post. Then tighten the nut one additional turn. Do not over-tighten the terminals, or they will be very difficult to remove for future service.

- 7 Coat the terminals and posts with spray-on battery terminal coating (available at most auto parts stores).
- 8 Put one of the black rubber boots over each of the terminals.

FILLING THE SOLUTION TANK

- 1 Either remove the Solution Fill Cap (22) or the Recovery Tank Dome Lid (2). **NOTE:** When filling the solution tank via the top of the Upper Tank (1), make sure that you pour the solution into the opening closest to the front of the machine.
- 2 Read the dilution instructions on the chemical container. Then figure the proper amount of chemical to mix with 40 gallons (151.41 liters) of water. For best results, use the Nilfisk-Advance CarpeTeam™ Extraction Cleaner chemical specially formulated for use with Nilfisk-Advance carpet extractors.
- 3 Pour the chemical into the solution tank and fill the tank with warm water. **NOTE:** Watch the Solution Level Indicator (21) as you fill the tank. When it reaches the 40 gallon mark, stop.
- 4 Put the Solution Filler Cap (22) or the Recovery Tank Dome Lid (2) back on the machine. **NOTE:** Make sure the Dome Lid is properly seated on the tank.

⚠ CAUTION!

Use low-sudsing, liquid detergents designed for carpet extraction.

BEFORE USING THE AQUAMAX™ / AX 650

Thoroughly vacuum the carpet to be cleaned before using the AquaMAX™ / AX 650 automatic extractor.

PRE-SPRAYING THE CARPET

Pre-spray spots and heavy traffic areas before extracting. Use a hand-held bottle sprayer or a pressurized "Hudson" type sprayer. Mix the pre-spray according to the chemical manufacturer's directions.

PLAN FOR CLEANING

Before you begin extracting, look at the area to be cleaned and plan your work. Divide the space into sections. Overlap each pass 2 inches (5 cm).

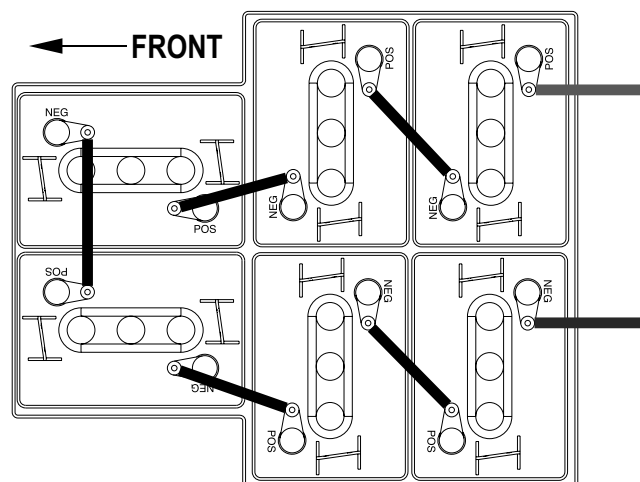

OPERATING THE MACHINE

- 1 Follow the instructions in the *Preparing the Machine for Use* section of this manual.
- 2 Make sure the Solution Fill Cap (22) and the Recovery Tank Dome Lid (2) are firmly in place.
- 3 Make sure the Pump Switch (5) and the Vacuum Switch (6) are both in the AUTO position.
- 4 Turn the Master Key Switch (4) ON.
- 5 Adjust the Nozzle Selector Knob (25) to either the "maintenance" or "restoration" mode. Set the Speed Control Knob (9) to the corresponding "maintenance" or "restoration" setting.
- 6 Lower the Brush Deck (20) to the floor using the Brush Deck Lift Lever (12).
- 7 When the Drive Paddle (11) is in the neutral position, the brush does not run and solution is not dispensed. Grip the Operator Control Handle (10) and push the Drive Paddle (11) forward to start the brush motor and the solution, and to move the machine forward. For best results, move the machine at full speed assuming that step 5 has been completed. Pull the Drive Paddle (11) backward to move the machine in reverse. The brush will turn in the opposite direction while moving the machine in reverse, and solution will not be dispensed.
- 8 Begin cleaning by driving the machine forward in a straight line and overlap each pass by 2 inches (5 cm). Turn the Pump Switch (5) OFF prior to turns to ensure complete extraction of solution from carpet. Guide the right side of the machine along the wall when cleaning the perimeter of the room.
- 9 Watch the fluid entering the Recovery Tank Dome Lid (2). If there is a large amount of suds in the recovery tank, add a defoamer chemical to the recovery tank.

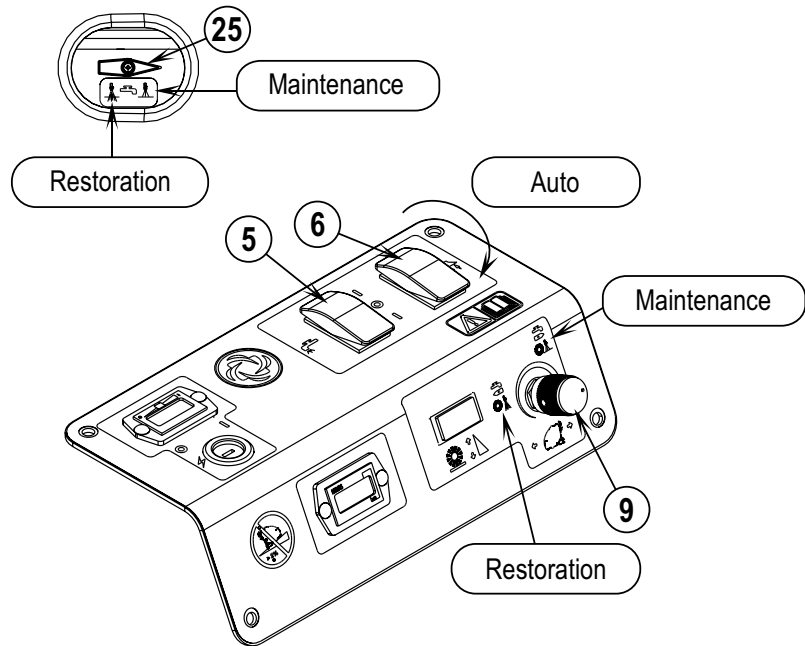

⚠ CAUTION!

Empty the recovery tank before the fluid or foam enters the Vacuum Hose (23) at the rear of the Recovery Tank Dome Lid.

If there is little or no fluid entering the recovery tank, check the Solution Drain Hose / Level Indicator (21), the solution tank may be empty. Refill the solution tank with water and the proper ratio of cleaning chemical.

- 10 The recovery tank has an Automatic Float Shut-Off (33) to block the vacuum system when the recovery tank is full. You can tell when the float closes by the sudden change in the sound of the vacuum motors. When the float closes, the recovery tank must be emptied. The machine will not pick up water with the float closed.
- 11 When the operator wants to stop cleaning or the recovery tank is full, raise the Brush Deck Lift Lever (12). This will automatically stop the brush, pump and vacuum motors.
- 12 Drive the machine to a designated waste water "DISPOSAL SITE" and empty the recovery tank. To empty, pull the Drain Hose (17) from its rear storage area, then remove the plug (hold the end of the hose above the water level in the tank to avoid sudden, uncontrolled flow of waste water). Refill the solution tank and continue cleaning.

USING ATTACHMENTS

To use accessory tools, attach the accessory recovery hose to the front port of the Recovery Tank Dome Lid (2). Attach the accessory solution hose to the Accessory Port (14). Connect the other ends of the hoses to the accessory tool. When using accessory tools, raise the Brush Deck (20) and place the Pump (5) and Vacuum (6) Switches in the ON position.

See your Nilfisk-Advance Distributor for accessories that may be used with the *AquaMAX™ / AX 650* including:

- 56250185 PowerHead™ 12
- 56204223 Drag Tool SS 4 Ft
- 56204224 Hand Tool SS
- 56249318 Scrub & Vac Hose 15 Ft
- 56801000 Aqua Kit (Includes PN 56800385, 56800390 & 56249318)
- 56800390 Drag Tool (Plastic)
- 56800385 Hand Tool (Plastic)

AFTER USING THE MACHINE

- 1 Raise the Brush Deck (12).
- 2 Turn the Master Key Switch (4) OFF.
- 3 To empty the solution tank, pull the Solution Drain Hose (21) off the elbow Direct the hose to a designated waste water "DISPOSAL SITE" and remove the plug. Rinse the tank with clean water. Inspect the solution hoses; replace if kinked or damaged.
- 4 To empty the recovery tank, take the Recovery Drain Hose (17) off its hanger. Direct the hose to a designated waste water "DISPOSAL SITE" and remove the plug (hold the end of the hose above the water level in the tank to avoid sudden, uncontrolled flow of waste water). Rinse the tank with clean water. Inspect the recovery and vacuum hoses; replace if kinked or damaged.
- 5 Remove the Brush (29), rinse with warm water and remove any built-up string, hair or carpet fibers.
- 6 Disconnect the Recovery Hose (24) from the Recovery Tank Dome Lid (2) and flush with warm water to wash any debris out of the Recovery Hose / Pick-Up Tool Assembly. NOTE: Make sure that you have disconnected the correct hose, if you run water into the vac motors they will be damaged.
- 7 Wipe the machine with a damp cloth. Do not use abrasive chemicals or solvents.
- 8 Perform any required maintenance before storage.

MAINTENANCE SCHEDULE

MAINTENANCE ITEM	Daily	Weekly	Monthly	Yearly
Charge Batteries	•			
Check / Clean Power Brush	•			
Check / Clean Tanks & Hoses	•			
Check / Clean Vacuum Shut-Off Float	•			
Check / Clean Vacuum Motor Filters	•			
Clean Pick-Up Tools	•			
Clean Spray Nozzles		•		
Check Each Battery Cell(s) Water Level		•		
Inspect Brush Deck Skirt		•		
Inspect & Clean InLine Pump Filter		•		
Lubricate the Machine			•	
*Check Carbon Brushes				•

* Have a Nilfisk-Advance service technician check the vacuum motor carbon brushes once a year or after 300 operating hours. The brush and drive motor carbon brushes check every 500 hours or once a year.

⚠ IMPORTANT!

Motor damage resulting from failure to service the carbon brushes is not covered under warranty. See the Limited Warranty Statement.

- 9 Store the machine in a clean, dry place with the tank dome lid open.

12 ENGLISH

PICK-UP TOOL MAINTENANCE

Check the pick-up tools daily. Remove any built-up string, hair or carpet fibers.

SPRAY NOZZLE MAINTENANCE

Remove the spray nozzles once a week. Soak the nozzles overnight in a vinegar and water solution to remove chemical deposits.

LUBRICATING THE MACHINE

Once a month (or every 30 hours), lubricate all pivot points on the pick-up tool assembly. For best results, use a spray silicone lubricant.

Once a month, pump grease into the grease fittings on the caster wheels until it seeps out around the bearing. Wipe off the excess grease to avoid staining carpet.

CLEANING THE VACUUM MOTOR FILTERS

Clean the vacuum motor filters daily with compressed air. For extremely dirty filters, wash with warm, soapy water and rinse thoroughly with clean water. Allow the filters to dry completely before re-installing in the machine. **MAINTENANCE NOTE:** Keep a second set of filters on hand to use while first set is drying.

ADJUSTING THE BRUSH HEIGHT

Simply turn the Brush Height Adjustment Knob (19) clockwise to raise and counter-clockwise to lower the brush deck. **NOTE:** The Brush Pressure Indicator (8) should read 8-15 amps when properly adjusted.

POWER BRUSH MAINTENANCE

Check the brush daily. Remove any built-up string, hair or carpet fibers. Check the bristle length. Have a service technician change the brush when the brush bristles are worn to 1/2 inch (12.7 mm).

REMOVING THE BRUSH

⚠ CAUTION!

Turn the key switch off (O) and remove the key, before changing the brushes, and before opening any access panels.

- 1 Turn the Master Key Switch OFF and raise the Brush Deck.
- 2 See figure below. Unsnap Latch (A), remove Pin (B) and Brush Access Door (C). Slide the brush out of the brush deck housing.
- 3 To reinstall, slide the brush under the brush deck housing, make sure the end with the large slots cut into it is inserted first.
- 4 Reach under the left side of the brush deck to guide the end of the brush onto the drive lug (E). Push in and turn the brush until it is firmly seated on the drive lug.
- 5 **IMPORTANT!** Make sure that the Bearing Block (D) is seated securely in the door and orientated as shown for "old style (F)", "new style (G)" machines have the bearing block attached to the access door. Hold the end of the brush up while re-installing Brush Access Door (C) to ensure that the Bearing Block on the inside of the door is securely seated in the end of the brush.
- 6 Re-install Pin (B) and re-secure Latch (A). Latch should secure easily. If it has to be forced, recheck the position of the brush.

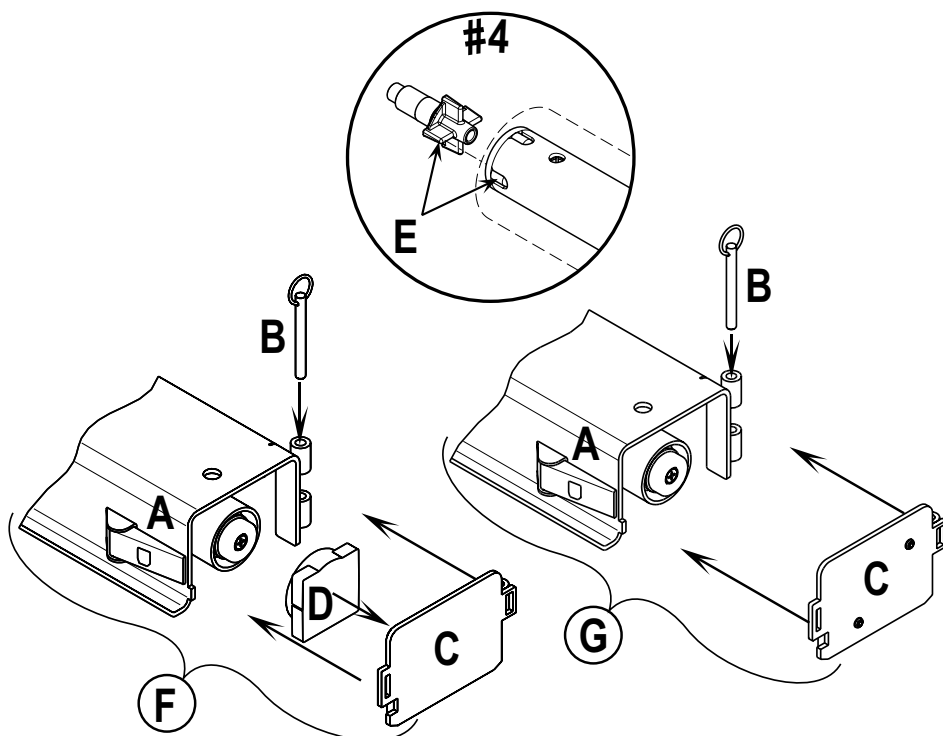

CHARGING THE BATTERIES

Charge the batteries when the Battery Fuel Gauge (3) shows a double flashing light.

WARNING!

Use extreme caution when working with batteries. Sulfuric acid in batteries can cause severe injury if allowed to contact the skin or eyes. Explosive hydrogen gas is vented from the batteries through openings in the battery caps. This gas can be ignited by any electrical arc, spark or flame.

When Servicing Batteries...

- * Remove all jewelry
- * Do not smoke
- * Wear safety glasses, rubber gloves and a rubber apron
- * Work in a well-ventilated area
- * Do not allow tools to touch more than one battery terminal at a time

Check the fluid level in each battery cell before charging. Add distilled water only until the water level is 1/4" above the plates. Push the connector from the charger into the Battery Charger Connector (16) on the machine. Follow the instructions on the battery charger.

CAUTION!

To avoid damage to floor surfaces, wipe water and acid from the top of the batteries after charging.

CHECKING THE BATTERY WATER LEVEL

Check the water level of the batteries at least once a week.

After charging the batteries, remove the vent caps and check the water level in each battery cell. Use distilled or demineralized water in a battery filling dispenser (available at most auto parts stores) to fill each cell to the level indicator (or to 10 mm over the top of the separators). **DO NOT** over-fill the batteries!

CAUTION!

Acid can spill onto the floor if the batteries are overfilled.

Tighten the vent caps. Wash the tops of the batteries with a solution of baking soda and water (2 tablespoons of baking soda to 1 liter of water).

BATTERY MAINTENANCE

Proper maintenance of electric vehicle batteries can greatly extend their life. Well-maintained batteries may last up to 3 years, but failure after 1 year is common if maintenance has been poor.

There are 3 simple rules for good battery maintenance:

- **Maintain Proper Electrolyte Level (Weekly)** - Use distilled water in batteries whenever possible. If batteries are discharged, add just enough water to cover the plates in each cell. If batteries are fully charged, fill each cell to the bottom of the filler tube. **Do not over-fill the batteries! Do not add acid to batteries!**
- **Keep the Batteries Charged (Weekly)** - Batteries should be charged each time that a machine is used for more than 1 hour. Machine operators should open the battery compartment cover for charging, to avoid a concentrated build-up of hydrogen gas. Even when a machine is stored, the batteries should be charged once a month to prevent the batteries from "sulfating". Almost all battery caps are vented, so there's no need to loosen or remove them for charging.
- **Keep the Batteries Clean (Monthly)** - Use a damp cloth to wipe dirt from the top of the batteries. Battery terminals must be clean and tight. If the tops of the batteries are wet after charging, the batteries have probably been over-filled or over-charged. Note: If there is acid on the batteries, wash the tops of the batteries with a solution of baking soda and water (2) tablespoons of baking soda to 1 quart of water.

BATTERY TESTING

A battery problem is usually recognized by the machine operator, as a decrease in the machine's running time. This condition is usually caused by one (or more) "dead cell" in the battery system- that is, one (or more) cell that is putting out less voltage than the other cells.

Note: Always charge batteries before testing.

There are 2 ways to find a dead cell:

- Use a hydrometer to check the specific gravity (or "state of charge") of the fluid in each cell. A dead cell is one that reads 50 points (or more) lower than the other cells.
- Use a volt meter to check the voltage of each battery with the brush motor running. The battery with the dead cell will read 1 or 2 volts lower than the other batteries in the system.

If the batteries in the machine are more than 1 year old, it's usually best to replace the whole set, rather than replacing just one battery.

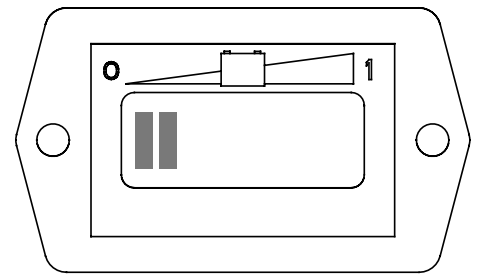

14 ENGLISH

6 AMP CONTROL CIRCUIT CIRCUIT BREAKER

When the Control Circuit Circuit Breaker (15) trips, push the button to reset the circuit breaker.

If the circuit breaker trips repeatedly, call your local Nilfisk-Advance Distributor for service.

20 AMP WHEEL DRIVE CIRCUIT BREAKER

When the Wheel Drive Circuit Breaker (15) trips, check to see if there is debris wrapped around the wheel axle. Remove the debris from the axle. Have the wheel drive motor checked for worn out brushes; repair or replace the motor if necessary. Push the button to reset the circuit breaker.

If the circuit breaker trips repeatedly, call your local Nilfisk-Advance Distributor for service.

20 AMP BRUSH DRIVE CIRCUIT BREAKER

When the Brush Drive Circuit Breaker (15) trips, check to see if the brush height is set too low or if there is debris wrapped around the brush. Adjust the brush height or remove the debris from the brush. Push the button to reset the circuit breaker.

If the circuit breaker trips repeatedly, call your local Nilfisk-Advance Distributor for service.

40 AMP VACUUM MOTOR CIRCUIT BREAKER

When the Vacuum Motor Circuit Breaker (15) trips, check the Vac Motor Filters (32) and clean or replace if necessary. Have the vacuum motors checked for worn out bearings and/or brushes or bearing failure. Repair or replace the motors if necessary. Push the button to reset the circuit breaker.

If the circuit breaker trips repeatedly, call your local Nilfisk-Advance Distributor for service.

TECHNICAL SPECIFICATIONS (as installed and tested on the unit)

Model	AquaMAX™ / AX 650	
Model No.	56212000 / 56212260	
Voltage, batteries	V	36V
Battery capacity	Ah	238
Protection grade		IPX3
Sound power level as per ISO 3744 (at operator)	dB(A)/20μPa	76
Gross weight (with acc. and batteries, full tank)	lbs / kg	1,171 / 531
Vibrations at the Hand Controls	m/s ²	<2,5m/s ²

TYPE: AX 650

<p>EU Overensstemmelseserklæring DK</p> <p>Tæpperensmaskine Maskinen er fremstillet i overensstemmelse med følgende direktiver: Maskindirektiv: 98/37/EØF EMC-direktiv: 89/336/EØF 92/31/EØF 93/68/EØF 98/13/EØF</p> <p>Lavspændingsdirektiv: 73/23/EØF 93/68/EØF Harmoniserede standarder: EN 60 335-2-72</p>	<p>Déclaration CE de conformité B, F</p> <p>Injecteur- extracteur Cette machine a été fabriquée conformément aux directives suivantes: Réglementation machine: 98/37/CEE Réglementation CEM: 89/336/CEE,92/31/CEE,93/68/CEE,98/13/CEE Règlement basse tension: 73/23/CEE 93/68/CEE Normes harmonisées: EN 60 335-2-72</p>
<p>EU Överensstämmelseförsäkran S, FIN</p> <p>Golvårdsmaskin Maskinen är tillverkad i överensstämmelse med följande direktiver: Maskindirektiv: 98/37/EEG EMC-direktiv: 89/336/EEG 92/31/EEG 93/68/EEG 98/13/EEG Lågspänningsdirektiv: 73/23/EEG 93/68/EEG Harmoniserade standarder: EN 60 335-2-72</p>	<p>EG-conformiteitsverklaring NL, B</p> <p>Sproei-extractie machine Deze machine is vervaardigd overeenkomstig de volgende richtlijnen: Machine richtlijn: 98/37/EEC EMC-richtlijn: 89/336/EEC 92/31/EEC 93/68/EEC 98/13/EEC Laagspanning richtlijn: 73/23/EEC 93/68/EEC Geharmoniseerde normen: EN 60 335-2-72</p>
<p>EU Declaration of Conformity GB, IRL</p> <p>Spray extraction machine This machine was manufactured in conformity with the following directives and standards: Machine Directive: 98/37/EEC EMC-directive: 89/336/EEC 92/31/EEC 93/68/EEC 98/13/EEC Low voltage directive: 73/23/EEC 93/68/EEC Harmonized standards: EN 60 335-2-72</p>	<p>Declaración de conformidad de la CEE E</p> <p>Máquina inyección/extracción Esta máquina ha sido fabricada en conformidad a las siguientes normativas: Normativa de la máquina: 98/37/CEE Normativa EMC: 89/336/CEE 92/31/CEE 93/68/CEE 98/13/CEE Normativa sobre baja tensión: 73/23/CEE 93/68/CEE Normas armonizadas: EN 60 335-2-72</p>
<p>Dichiarazione di conformità - CEE I</p> <p>Macchina ad estrazione È prodotto in conformità alle disposizioni contenute nelle Direttive del Consiglio dei Ministri: M-direttiva: 98/37/EEC EMC-direttiva: 89/336/EEC 92/31/EEC 93/68/EEC 98/13/EEC LV-direttiva: 73/23/EEC 93/68/EEC Norme armonizzate: EN 60 335-2-72</p>	<p>EU Declaração de conformidade da CE P</p> <p>Máquina de injeção/extracção Esta máquina foi fabricada em conformidade com as seguintes directrizes: Directriz de maquinaria: 98/37/CEE Directriz EMC: 89/336/CEE 92/31/EEC 93/68/CEE 98/13/CEE Directriz de baixa voltagem: 73/23/CEE 93/68/CEE Normas harmonizadas: EN 60 335-2-72</p>
<p>EG – Konformitätserklärung D, A</p> <p>Sprühextraktionsmaschine Diese Maschine wurde gemäß den folgenden Richtlinien hergestellt: Maschinerichtlinie: 98/37/EWG EMV-Richtlinie: 89/336/EWG 92/31/EWG 93/68/EWG 98/13/EWG Niederspannungsrichtlinie: 73/23/EWG 93/68/EWG Harmonisierte normen: EN 60 335-2-72</p>	<p>EU:n yhdenmukaisuudesta direktiiveihin FIN</p> <p>Painehuuhtelukone On valmistettu noudattaen yhteisön määrittämiä direktiivejä: M-direktiivi: 98/37/CEE EMC-direktiivi: 89/336/CEE 92/31/CEE 93/68/CEE 98/13/CEE LV-direktiivi: 73/23/CEE 93/68/CEE Yhdenmukaistetut standardit: EN 60 335-2-72</p>
<p>Δηλώση προσαρμογής/συνόρφωσης EU GR</p> <p>Μηχανήμα καθαρισμού χαλιών ψεκασμού-αναρρόφησης Το μηχανήμα έχει κατασκευαστεί ονμψωπα με τις παρακάτω προσαρμογές: Προσαρμογή μηχανήματος: 98/37/EEC Προσαρμογή-EMC: 89/336/EEC,92/31/EEC,93/68/EEC,98/13/EEC Προσαρμογή χαμηλής τάσεως: 73/23/EEC 93/68/EEC Εναρμονισμένα προτυπα: EN 60 335-2-72</p>	<p>EL vastavusdeklaratsioon ET</p> <p>Pihustusmasin Käesolev masin on valmistatud kooskõlas järgmiste direktiivide ja standarditega: Masinadirektiiv: 98/37/EEC Elektromagnetilise sobivuse direktiiv: 89/336/EEC 92/31/EEC 93/68/EEC 98/13/EEC Madalpinge direktiiv: 73/23/EEC 93/68/EEC Ühtlustatud standardid: EN 60 335-2-72</p>
<p>ES atbilstības deklarācija LV</p> <p>Šļakatu ekstrakcijas mašīna Šī mašīna izgatavota atbilstoši šādām direktīvām un standartiem: Mašīnu direktīva: 98/37/EEC Elektromagnētiskās savietojamības (EMC) direktīva: 89/336/EEC 92/31/EEC 93/68/EEC 98/13/EEC Zemsprieguma direktīva: 73/23/EEC 93/68/EEC Saskaņotie standarti: EN 60 335-2-72</p>	<p>Pareiškimas apie atitikimą ES direktyvoms LT</p> <p>Skysčio surinkimo mašina Šis įrenginys pagamintas laikantis tokių direktyvų bei standartų: Įrengimų direktyva: 98/37/EEC EMC direktyva: 89/336/EEC 92/31/EEC 93/68/EEC 98/13/EEC Žemos įtampos įrengimų direktyva: 73/23/EEC 93/68/EEC Harmonizuoti standartai: EN 60 335-2-72</p>

<p>Deklaracija EU o skladnosti SL Stroj za razprševanje čistila Ta stroj je izdelan v skladu z naslednjimi smernicami in standardi:</p> <p>Smernica o strojih: 98/37/EEC Smernica o elektromagnetni združljivosti (EMC): 89/336/EEC 92/31/EEC 93/68/EEC 98/13/EEC Smernica o nizki napetosti: 73/23/EEC 93/68/EEC Harmonizirani standardi: EN 60 335-2-72</p>	<p>Prehlásenie o súlade EÚ SK Zariadenie na odsávanie povrchového postreku Toto zariadenie bolo vyrobené v súlade s nasledujúcimi direktívami a normami:</p> <p>Direktíva o zariadeniach: 98/37/EEC Direktíva EMC: 89/336/EEC 92/31/EEC 93/68/EEC 98/13/EEC</p> <p>Direktíva o nízkom napätí: 73/23/EEC 93/68/EEC Súvisiace normy: EN 60 335-2-72</p>
<p>EU Prohlášení o shodě CS Odsávací stroj Tento stroj byl vyroben ve shodě s následujícími směrnicemi a normami:</p> <p>Směrnice o strojním zařízení: 98/37/EEC Směrnice o elektromagnetické kompatibilitě: 89/336/EEC 92/31/EEC 93/68/EEC 98/13/EEC Směrnice o nízkém napětí: 73/23/EEC 93/68/EEC Harmonizované normy: EN 60 335-2-72</p>	<p>Deklaracja zgodności z normami UE PL Urządzenie do wysokociśnieniowego prania dywanów Niniejsze urządzenie zostało wyprodukowane w zgodzie z następującymi dyrektywami i normami UE:</p> <p>Dyrektywa dotycząca maszyn: 98/37/EEC Dyrektywa: kompatybilność elektromagnetyczna 89/336/EEC 92/31/EEC 93/68/EEC 98/13/EEC Dyrektywa: urządzenia elektromagnetyczne niskonapięciowe 73/23/EEC 93/68/EEC Zharmonizowane normy: EN 60 335-2-72</p>
<p>EU megfeleléségi nyilatkozat HU Permettfelszívógép Ez a gép az alábbi irányelvekkel és szabványokkal összhangban készült:</p> <p>Gépészeti irányelvek 98/37/EEC EMC-irányelvek 89/336/EEC 92/31/EEC 93/68/EEC 98/13/EEC Kisfeszültségű irányelvek: 73/23/EEC 93/68/EEC Harmonizált szabványok: EN 60 335-2-72</p>	<p>Декларация изготовителя о соответствии директивам ЕС Распылительный пылесос Данная машина разработана в соответствии со следующими инструкциями и стандартами:</p> <p>Инструкция по разработке машин: 98/37/EEC Инструкция EMC: 89/336/EEC 92/31/EEC 93/68/EEC 98/13/EEC Инструкция по использованию низких напряжений: 73/23/EEC 93/68/EEC Согласованные стандарты: EN 60 335-2-72</p>
<p>EU Uygunluk Beyanı TK Bataryayla çalışan zemin fırçalama sistemi . Bu makine aşağıdaki direktiflere ve standartlara uygun olarak üretilmiştir. Makine Direktifi : 98/37/EEC EMC Direktifi : 89/336/EEC 92/31/EEC 93/68/EEC 98/13/EEC Düşük voltaj Direktifi : 73/23/EEC 93/68/EEC Uyumlu standartlar :EN 60 335-2-72</p>	



4.4.2004 .

Larry Doerr, Vice President Operations

Nilfisk-Advance, Inc.
14600 21st Avenue North
Plymouth, MN 55447 USA

Nilfisk-Advance A/S
Sognevej 25
DK-2605 Brøndby, Denmark

