

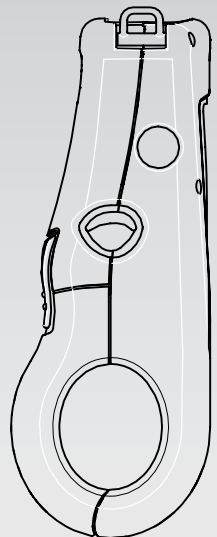

# QL 320<sup>tm</sup>

## Mobile Printer User's Guide

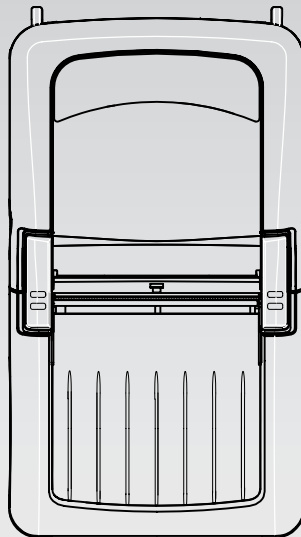
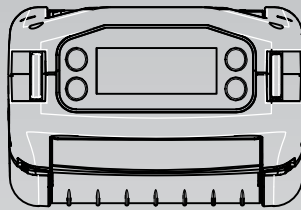

## Proprietary Statement

This manual contains proprietary information of Zebra Technologies Corporation. It is intended solely for the information and use of parties operating and maintaining the equipment described herein. Such proprietary information may not be used, reproduced, or disclosed to any other parties for any other purpose without the expressed written permission of Zebra Technologies Corporation.

## Product Improvements

Since continuous product improvement is a policy of Zebra Technologies Corporation, all



# *QL 320<sup>tm</sup>*

Mobile Printer  
User's Guide

# Contents

Introduction .....	7
Unpacking and Inspection .....	7
Reporting Damage .....	7
Getting Ready to Print.....	9
Battery .....	9
<i>Installing the Battery</i> .....	9
<i>Charging the Battery</i> .....	9
Loading the Media .....	10
<i>Installing the Media</i> .....	10
Operator Controls .....	13
<i>Standard Keypad</i> .....	13
<i>LCD Control Panel</i> .....	15
Verify the Printer Is Working .....	18
<i>Printing a Configuration Label</i> .....	18
Connecting the Printer .....	18
<i>Cable Communications</i> .....	19
<i>IR Communications</i> .....	20
<i>SRRF Communications</i> .....	21
<i>Zebra SRRF Network Overview</i> .....	21
<i>Bluetooth™ Networking Overview</i> .....	23
<i>Wireless Local Area Network (WLAN)</i> .....	25
Setting Up the Software .....	26
Adjustable Shoulder Strap .....	27
Belt Clip .....	28
Preventive Maintenance .....	29
Extending Battery Life.....	29
Cleaning.....	31
Troubleshooting .....	32
Standard Control Panel.....	32
Optional LCD Control Panel.....	32
Troubleshooting Topics .....	33
Troubleshooting Tests .....	34
<i>Printing a Configuration Label</i> .....	34
<i>Sample Configuration Label</i> .....	35
<i>Communications Diagnostics</i> .....	37
<i>Calling the Help Desk</i> .....	37
Specifications .....	38
Printing Specifications .....	38
Memory/Communications Specifications.....	38



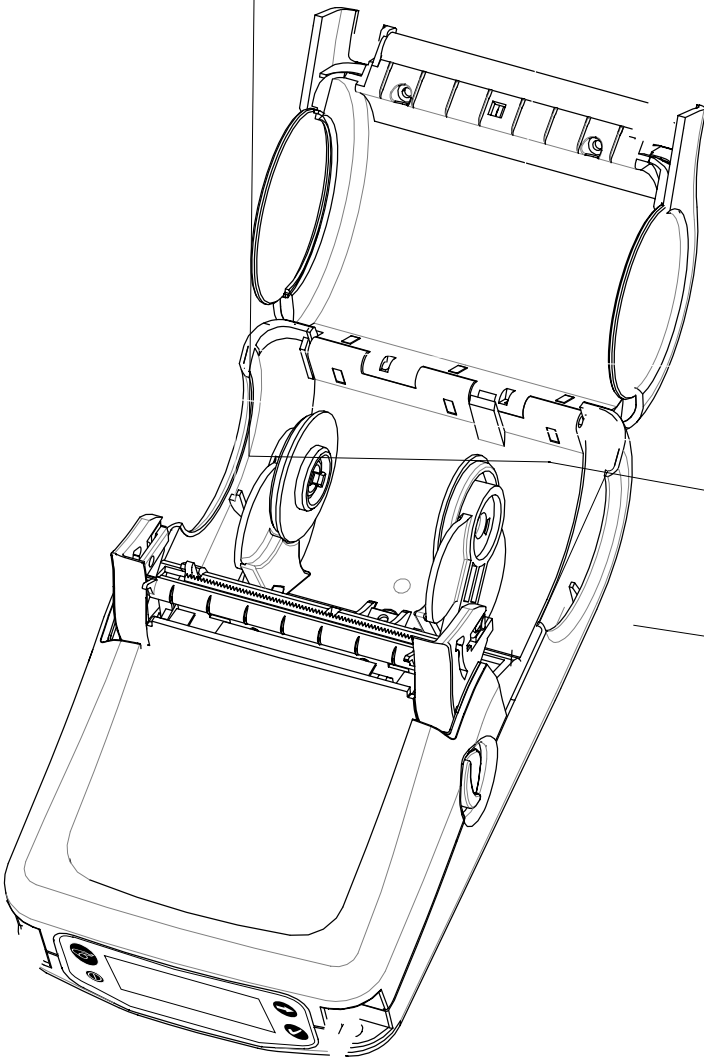

# Introduction

Thank you for choosing our Zebra QL 320 Mobile Printer. This rugged printer is sure to become a productive and efficient addition to your workplace thanks to its innovative design. Because it's made by Zebra Technologies Corporation, you're assured of world-class support for all of your bar code printers, software, and supplies.

- This user's guide gives you all the information you'll need to operate the QL 320 printer.
- The QL 320 uses the CPL programming language. To create and print labels using the CPL language, refer to the Mobile Printer Programming Guide and our Label Vista™ label creation program.
- The QL 320 has an optional interpreter for the ZPL II® Programming Language which interprets commands up to X.8 firmware. The printer must be equipped with the optional memory upgrade and appropriate application in order to use this function. A ZPL II Program Guide (part #46530L) can be used as reference for the ZPL II label design programming language. If either manual was not ordered with the printer, simply call your re-seller or Zebra Technologies Corporation or visit the Zebra web site..

## Unpacking and Inspection

Inspect the printer for possible shipping damage:

- Check all exterior surfaces for damage.
- Open the media cover (refer to “Loading the Media” in the Getting Ready to Print section) and inspect the media compartment for damage.

In case shipping is required, save the carton and all packing material.

## Reporting Damage

If you discover shipping damage:

- Immediately notify and file a damage report with the shipping company. Zebra Technologies Corporation is not responsible for any damage incurred during shipment of the printer and will not cover the repair of this damage under its warranty policy.
- Keep the carton and all packing material for inspection.
- Notify your authorized Zebra re-seller.

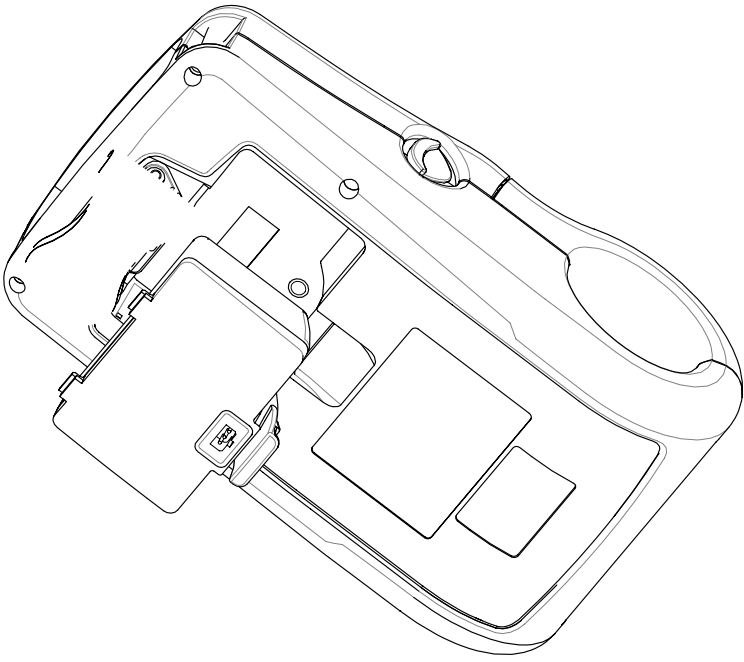



## Battery

### Installing the Battery



**NOTE:** Batteries are shipped uncharged. Remove protective shrink-wrap and labels from new battery packs prior to use.

1. If the printer is so equipped, rotate the Belt Clip to allow access to the Battery compartment.
2. Insert the battery into the printer as shown in Figure 2,
3. Rock the Battery into the printer as shown until it locks in place.

When the battery is first installed, the Control Panel indicators may briefly turn on and then go off which indicates the battery is not fully charged (see “Charging the Battery” below and “Operator Controls”).

### Charging the Battery

Refer to Figure 3. Your battery charger may look slightly different from the ones illustrated.

If you are using the LI 72 battery charger:

1. Install the battery in the printer and plug the Charger into the appropriate A.C. wall receptacle. Then insert the charge cable into the battery charger jack.
2. The charger LED will indicate the status of the charger as follows:
  - A steady light indicates the battery is undergoing a fast charge.
  - A slow blinking light indicates the charger is in trickle mode. The battery is ready for use.
  - A rapidly blinking light indicates a problem with the battery. The battery may have an internal short, or its charge monitoring circuitry may be malfunctioning. The battery should not be used any further.
- Battery Packs may be charged either when installed in the printer or when removed.



**Do not attempt to charge batteries with the LI 72 while printing. Attempting to print while charging can result in improperly charged batteries.**

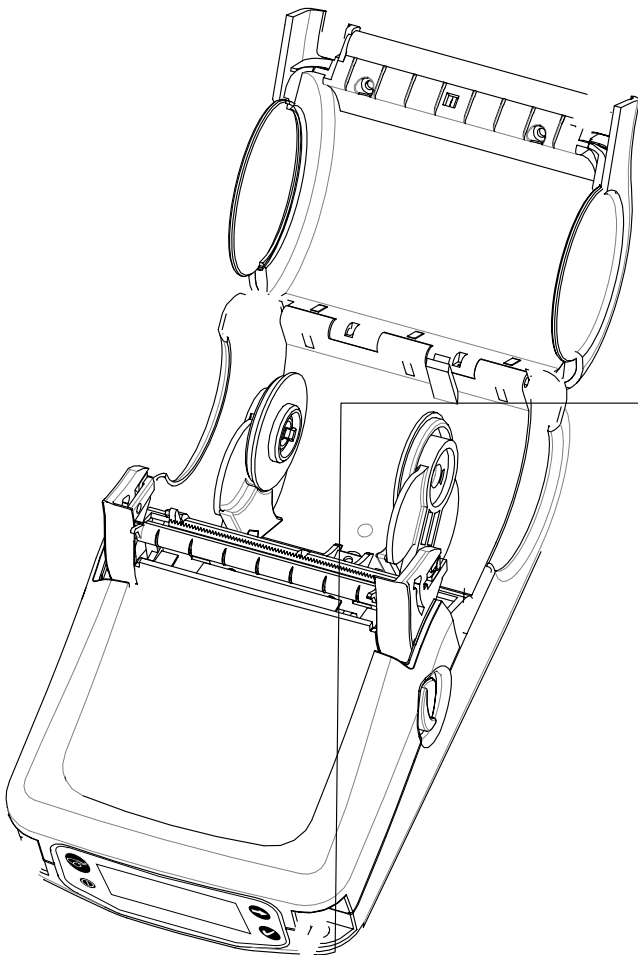

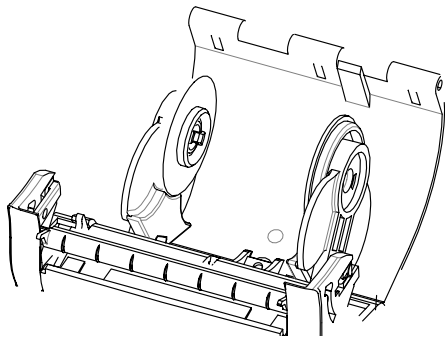

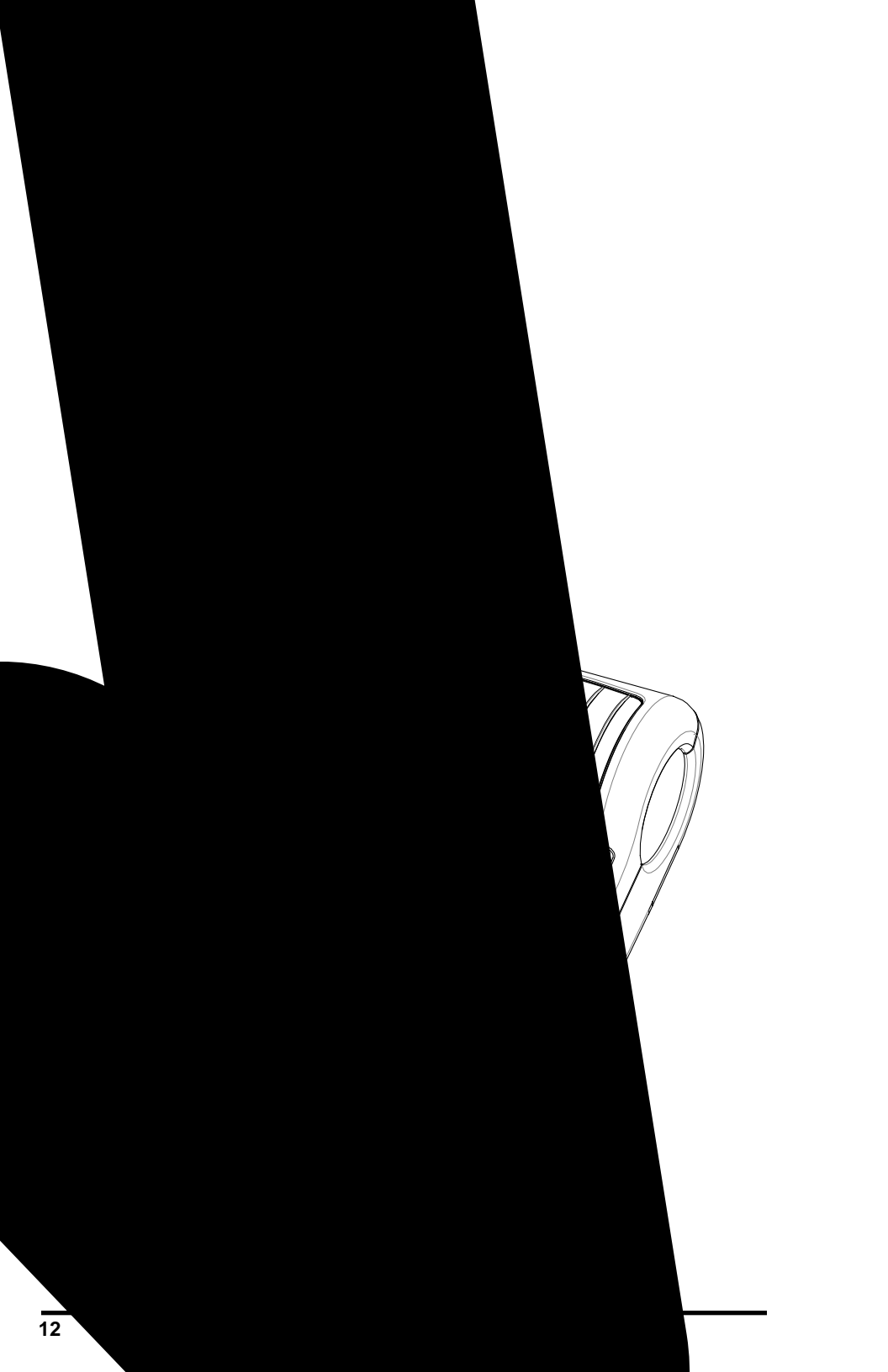

# Operator Controls

The QL 320 will come with one of two possible control panels. The standard control panel is detailed below and in Figure 8. The optional control panel (Figure 9) features an LCD which allows easy display and selection of many printer functions and is detailed on following pages.

## Standard Keypad

The standard keypad has three control buttons and two multi-purpose indicators.

- The Power button turns the QL 320 on and off.
- The Feed button advances a length of media which is determined by the type of media being used. Label media will be advanced to the next gap or bar sense marker. Journal (plain) media will be advanced a length determined by the printer's software.
- The Function button is controlled by a printer's specific application to support such functions as:
  - Print a battery Level reporting
  - Print the Local Area Network (LAN) status
  - Print a Short Range Radio Frequency (SRRF) status
  - Print a Media supply report

The green LED on the left side of the control panel indicates the status of several printer features:

- A slowly blinking sequence indicates the printer's battery needs charging.
- Printers with a wireless QuickLink module installed: a quickly blinking sequence indicates the printer has not established a link to either a Local Area Network or a compatible wireless equipped terminal.
- Printers with a wireless QuickLink module installed: A steadily lit indicator shows that the printer has established a wireless link, either to the LAN or to a compatible terminal. A steadily lit green indicator on a non-wireless printer is a power-on indicator.

The yellow LED on the right side of the control panel has two indication conditions.

- A rapidly blinking yellow LED and a chime indicate that no application has been loaded into the printer.
- Printers with a wireless QuickLink module installed: a rapidly blinking LED indicates normal data transmission.

- A steadily lit yellow LED indicates an error condition. This can be caused by one of the following:
  1. The media cover is not completely closed and latched.
  2. The printer is out of media.

*Green LED*

**Steady Light indicates power on and/or established RF link.**

**Fast Blink indicates no RF link (on RF equipped units only)**

**Slow Blink means low battery**

*Power Button*

**Press to turn unit on. Press again to turn unit off**

*Yellow LED*

**Steady Light indicates error condition: out of media or media cover not closed.**

**Fast Blink indicates RF activity (on RF equipped units only)**

**Fast blink with beeper indicates no application loaded**

*Feed Button*

**Press to advance the media one blank label or a software determined length of journal media.**

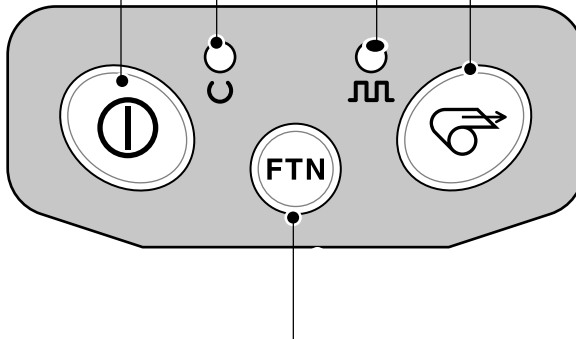

*Function Button*

**Specific functions are under printer application control.**

*FIGURE 8: STANDARD CONTROL PANEL*

## LCD Control Panel

The optional LCD control panel has buttons for the power on/off and media feed functions just as in the standard control panel. In addition, it has two keys which allow easy navigation and selection of menu options affecting many printer functions.

The “Scroll” button allows scrolling through the various options and settings. The “Select” button allows selection of the option or function displayed on the screen.

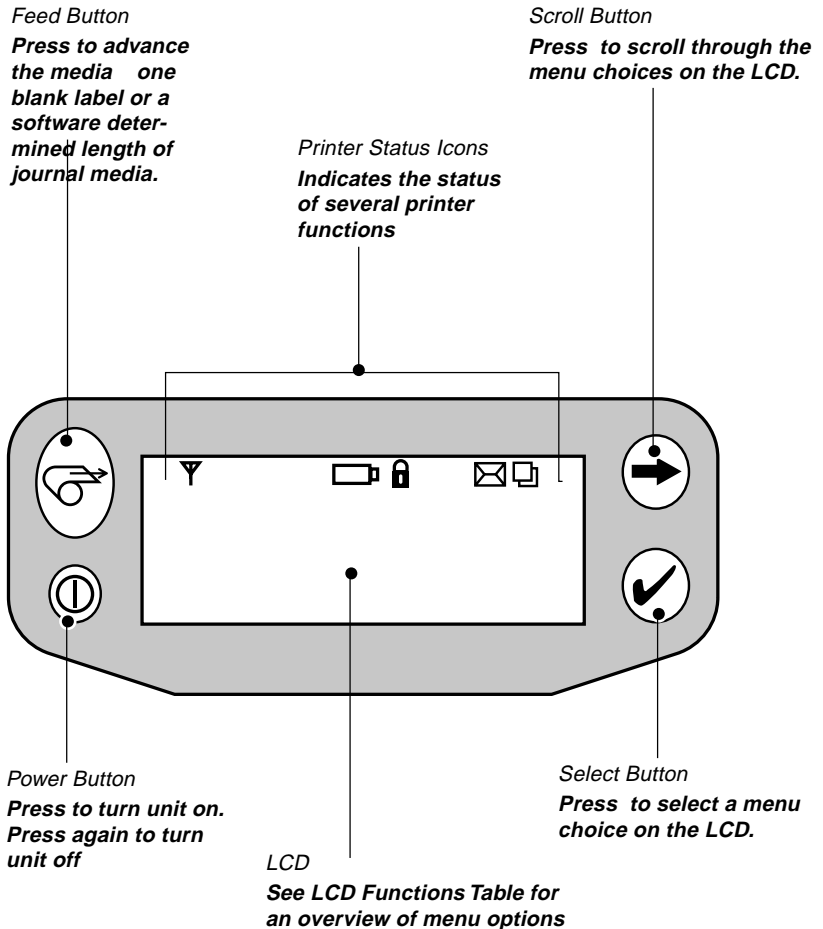





FIGURE 9: OPTIONAL LCD CONTROL PANEL

The top of the screen has a row of status icons which indicate the state of various printer functions:

 Indicates that the printer is associated with a wireless Local Area Network (LAN). This icon is functional only with QL 320N network printers.

 A flashing icon indicates low battery status. You should suspend any printing operations and recharge or replace the battery Pack as soon as is convenient.

 A flashing icon indicates that the media cover is open or not properly latched.

 A flashing icon indicates that a file is being downloaded to the printer.

 A flashing icon indicates that the printer does not detect any media. This could indicate an out of media condition, or improperly loaded media.

In addition to the status icons, the LCD control panel can display many of the printer's settings and functions as text. Applications can be written to allow the user to view and /or modify these settings using the scroll and select keys on the display. Refer to the "LCD Functions Table" on the following page for the full set of printer features that can be made available with the LCD panel.

The LCD has a backlighting option which allows viewing of the screen in a dark environment, or provides better contrast in a very bright environment. Use of the display backlight will decrease the time the printer will run between charges.



## LCD Functions

Function	Default setting	Scroll & Select Options
Sensor Type	Gap	<ul style="list-style-type: none"> <li>• Bar</li> <li>• Gap</li> </ul>
Print Width	Factory Set Value	<ul style="list-style-type: none"> <li>• Increase (+120 dots max.)</li> <li>• Decrease (-120 dots max.)</li> </ul>
Baud Rate	19200	<ul style="list-style-type: none"> <li>• 9600</li> <li>• 19200</li> <li>• 32400</li> </ul>
Data Bits	8	<ul style="list-style-type: none"> <li>• 7</li> <li>• 8</li> </ul>
WLAN ID*	Factory Set Value	N/A
Label Top	000	<ul style="list-style-type: none"> <li>• Increase (+120 dots max.)</li> <li>• Decrease (-120 dots max.)</li> </ul>
Left Position	000	<ul style="list-style-type: none"> <li>• Increase (+120 dots max.)</li> <li>• Decrease (-120 dots max.)</li> </ul>
LCD Contrast	0	<ul style="list-style-type: none"> <li>• Increase</li> <li>• Decrease</li> </ul>
No-activity Timeout	60 sec.	<ul style="list-style-type: none"> <li>• 60 sec.</li> <li>• 5 min.</li> <li>• 10 min.</li> <li>• 30 min</li> <li>• Custom*</li> </ul>
Print Darkness (Head Temperature)	00	<ul style="list-style-type: none"> <li>• Increase (+10 max.)</li> <li>• Decrease (-10 max.)</li> </ul>
Tear-off Position	00	<ul style="list-style-type: none"> <li>• Increase (+120 dots max.)</li> <li>• Decrease (-120 dots max.)</li> </ul>
Media Type	Label	<ul style="list-style-type: none"> <li>• Label</li> <li>• Journal</li> </ul>
LCD Backlight	Off	<ul style="list-style-type: none"> <li>• On</li> <li>• Off</li> <li>• Momentary On w/ time delay</li> </ul>
Factory Reset (Resets all to factory set values)	No	<ul style="list-style-type: none"> <li>• No</li> <li>• Yes</li> </ul>

\* Some parameters, such as the WLAN ID number and non-standard no-activity time out values can be set using a PC running Zebra's Label Vista label creation program and a data cable link to the printer.

## Verify the Printer Is Working

Before you connect the printer to your computer or portable data terminal, make sure that the printer is in proper working order. You can do this by printing a configuration label using the “two key reset” method. If you can’t get this label to print, refer to “Troubleshooting”.

### Printing a Configuration Label

1. Turn the printer off. Load the media compartment with journal media (media with no black bars printed on the back)
2. Press and hold the Feed Button.
3. Press and release the Power button and keep the Feed button pressed. When printing starts, release the Feed button.

The unit will print a line of interlocking “x” characters to insure all elements of the print head are working, print out the version of software loaded in the printer and then print two reports.

The first report indicates model, ROM version, serial number, baud rate, etc. The second report prints out more detailed information on the printer’s configuration and parameter settings. If no second report appears, there is no application loaded. (See the Troubleshooting Section for a sample print-out and a further discussion on how to use the configuration label as a diagnostic tool.)

### Connecting the Printer

The printer must establish communications with a host terminal which sends the data to be printed. Communications occur in four basic ways:

- By a cable between the printer and its host terminal
- Linking to a host terminal via Infrared (usually by means of the industry standard IrDA protocol)
- By means of a Short Range Radio Frequency (SRRF) link.
- By means of a wireless LAN (Local Area Network). This applies to QL 320N Network Printers only.

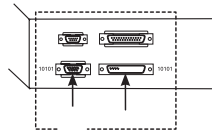
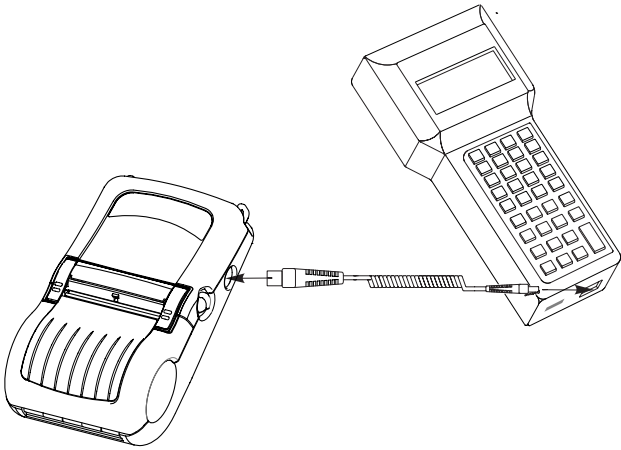

## IR Communications

Printers equipped for infrared (IR) communications are identified by a small "IR" logo on the unit's label. IR allows wireless communications between the printer and the host terminal. IR units can also communicate with a cable as detailed above, however, IR functions are disabled when the cable is plugged in. QL 320 units with the IR option can be configured to conform to the standard IrDA communications protocol

### *Linking a Printer to an IrDA Host*

IrDA compliant terminals will automatically initiate communications to the printer. First insure that there is a direct line of sight between the printer and the terminal that will be sending data. The IR window on the front of the QL 320 must face the corresponding window on the terminal to properly send and receive signals. An IrDA compliant terminal will seek out any linkable devices and establish communications between them, even turning the printer on if necessary.

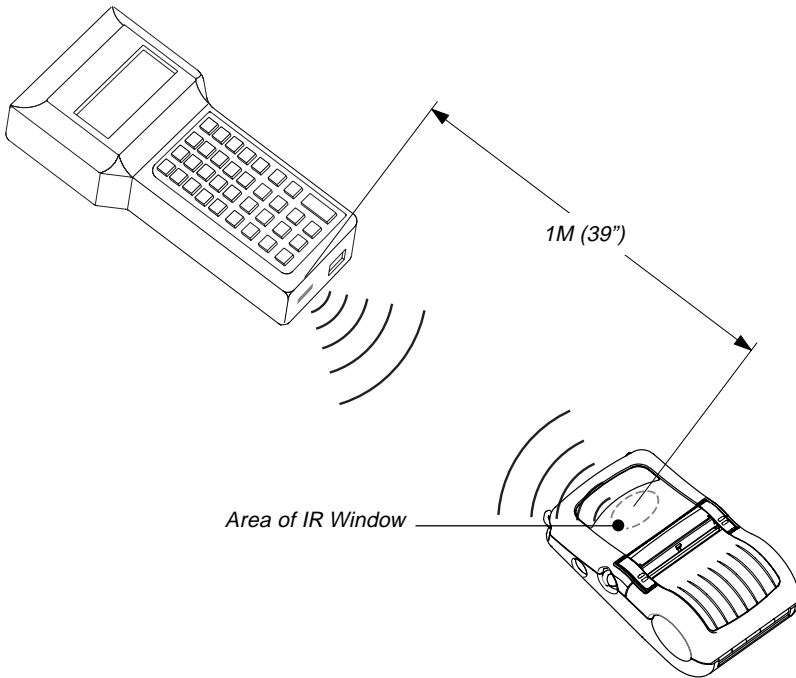

FIGURE 12

## **SRRF Communications**

Both the printer and the device it communicates with must follow either the Bluetooth standard or Zebra's proprietary SRRF protocol. The communications protocol is determined by the specific QuickLink module installed in the printer.

Printers equipped for short range radio frequency communications (SRRF) allow wireless communication with their host terminals from any direction. Reliable transmission distances will vary but usually exceed 1m. (39") under worst conditions. SRRF printers can be identified by reading the printer's model number label on the front of the unit, which will show the radio module's identification number and/or its operating frequency. QL 320 printers equipped with a Bluetooth wireless module will have the Bluetooth logo on the model number label.

### **Zebra SRRF Network Overview**

Zebra's short range RF network operates as a collection of linked pairs of terminals and printers. There is no base station or centralized control; control of the network is distributed across the entire network.

Before SRRF operation can begin, the QL 320 must be "linked" to a terminal with a compatible short-range radio. Linking means that addresses are exchanged between the terminal and the printer. Once linked, the terminal and the printer become a "linked pair" and communicate exclusively with each other. The terminal and the printer can be turned on and off without affecting the link; it remains valid until another link is deliberately created. Thus it is not necessary to perform a link every time that the equipment is used. So long as the linked pair is kept together, they remain linked indefinitely. If the linked pair is not stored together, then the terminal and printer selected should be linked prior to use.

Multiple linked pairs can be operated in close quarters and each terminal will only communicate with its linked printer. Each SRRF radio module has a unique device address (terminal or printer), based on the device serial number.

#### ***Linking From the Terminal to the Printer***

The linking operation can be activated from either the terminal or the printer. If the terminal has a scanner available, then the bar-coded serial number on the back of every printer can be scanned and used to establish the printer's unique address. Once the printer's address is established, the terminal can then initiate a link to that printer. If no scanner is available the user can manually enter

the serial number of the printer; however, this method is not recommended. The terminal can only capture the desired printer using this type of link.

The terminal must be programmed to guide the user through scanning the printer serial number bar-code, then execute an algorithm which converts the serial number into an address. Zebra can provide C source code to licensed OEM customers that handles the conversion from serial number to address.

### ***Linking From the Printer to the Terminal***

When no scanner is available, and/or no additional software is to be written for the terminal, then the linking operation can be initiated solely by the printer.

In this procedure the printer broadcasts a message seeking an available terminal. If a terminal “hears” the broadcast and is available, it will respond by linking to the printer.

To insure a secure link, the user must perform the link operation far enough away from other operating terminals so that the printer does not inadvertently capture some other user’s terminal. Any other terminal that hears the broadcast message from the printer may try to link to it, therefore you should insure that only one terminal is within broadcast range. Feedback is available from the printer as to the outcome of the link operation.

# Bluetooth™ Networking Overview



## ***Exposure to Radio Frequency Radiation***

***The radiated output power of this internal wireless radio is far below the FCC radio frequency exposure limits. Nevertheless, this Bluetooth radio must be used in such a manner that the antenna is 2.5 cm or further from the human body.***

***The radio and antenna are mounted internally in this printer in such a way that, when the printer is used in a standard configuration (belt clip, soft case, shoulder strap), the 2.5 cm distance from the users body will be met. Do not use the printer in an unauthorized manner.***

***The internal wireless radio operates within guidelines found in radio frequency safety standards and recommendations. The level of energy emitted is far less than the electromagnetic energy emitted by wireless devices such as mobile phones.***

“Bluetooth” is a worldwide standard for the exchange of data between two devices via radio frequencies. Bluetooth radios are relatively low powered to help prevent interference with other devices running at similar radio frequencies. This limits the range of a Bluetooth device to about 10 meters (about 32 feet).

In order to exchange data, two Bluetooth enabled devices must establish a connection. Bluetooth software is always running in the background, ready to respond to connection requests. One device (known as the *master* or the *client*) must request a connection with another. The second device (the *slave* or the *server*) then accepts or rejects the connection. A Bluetooth enabled QL 320 will normally act as a slave, but in theory any Bluetooth device can be either a master or a slave. This miniature network is sometimes referred to as a “piconet” and can consist of several Bluetooth enabled devices.

Each Bluetooth QL 320 has a unique Bluetooth Device Address (BDA) loaded into its Quick Link module when manufactured.

### ***A Typical Bluetooth Connection Sequence***

In this simplified sequence “Joe’s Terminal” is a Bluetooth ready hand held terminal running an application that needs access to a printer.

1. Joe’s Terminal performs a search of its “piconet” (a Device In-

quiry) and determines that there are four Bluetooth devices in the vicinity.

2. Joe's Terminal queries each of the four nearby devices to determine which services they provide (a Service Discovery). The Bluetooth enabled QL 320 "Sandy's Printer" offers the printing service.

3. Joe's Terminal sends a print connection request to Sandy's Printer.

4. Sandy's Printer evaluates the request and determines that Joe's Terminal is permitted to use the print service, *but only if the correct password is submitted.*

5. Sandy's Printer queries Joe's Terminal for the password (Authentication).

6. Joe's Terminal returns the correct password and the print connection is established.

7. After Joe's Terminal is finished printing it disconnects with Sandy's Printer. (Some Bluetooth services disconnect automatically, others must be closed manually.)

There are several layers of security in the Bluetooth system, so this sequence may not be a completely accurate representation of how your printer may function in a Bluetooth environment. For the most part, communications using the Bluetooth protocol are initiated and processed without any operator intervention, much like the IrDA system described previously.



## Wireless Local Area Network (WLAN)



***WARNING: Use of the QL 320 will result in exposure to Radio Frequency radiation. To conform to FCC RF exposure requirements the printer must be used only in the intended orientation and in the intended manner.***

Printers equipped for Wireless Local Area Network (WLAN) communications using the industry standard 802.11 or 802.11b protocols are known as QL 320N Printers. These printers allow wireless communication as a node within a local area network, and its wireless capabilities allow communications from any point within the LAN's perimeter. Methods of establishing communications to the QL 320 will vary with each LAN application.

QL 320N printers can be identified the model number on the front of the unit.

The QL 320N is designed for use with either a shoulder strap and a specially designed soft case, or with a belt clip. The printer should be oriented on the operator's hip so that printed material is transported away from the operator.

When the QL 320N is used as designed, either the printer's soft case or the belt clip will allow use of the printer in the manner mandated by the FCC.

## Setting Up the Software

The QL 320 uses Zebra's CPL Programming language which was designed for mobile printing applications. CPL is fully described in the Mobile Printing Systems Programming Manual, which is available in Portable Document Format (.pdf) on-line at Zebra's website

You can also use Label Vista™, Zebra's Windows™ based label creation program which uses a graphical interface to create and edit labels in the CPL language. Label Vista is available either on-line at Zebra's website, or on a CD (part number AC15065-1).

The QL 320 with its optional memory upgrade can support an interpreter for ZPL II®, the programming language used by Zebra desktop printers. To use ZPL II, refer to the ZPL II Programming Guide. If you choose to use a third party label preparation system, follow the installation instructions included in the package.

## Adjustable Shoulder Strap

Refer to Figure 14, below.

Snap each end of the shoulder strap into the “D” rings in the top of the printer. Slide the buckle away from or towards the printer until you achieve the desired length.

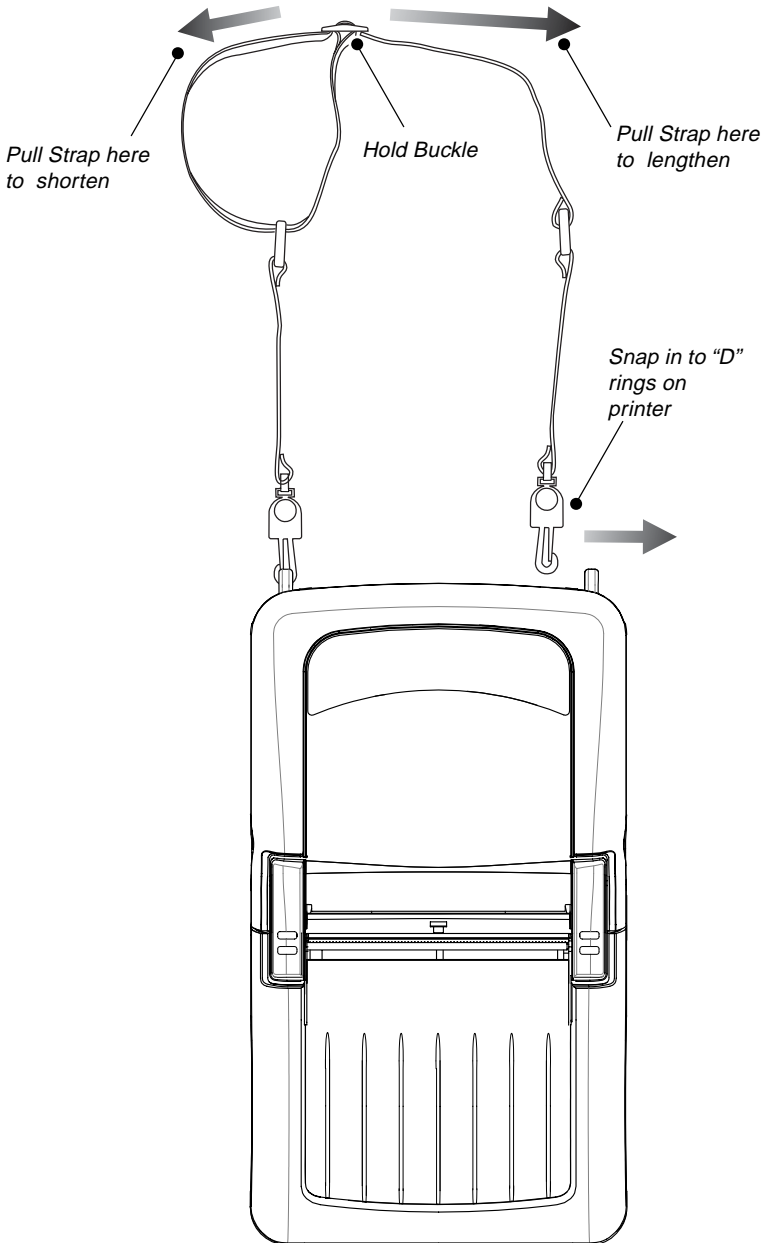

FIGURE 14

## Belt Clip

If the QL 320 is equipped with a belt clip, hook the clip over your belt, and ensure that the clip is securely attached to the belt. The belt clip will pivot to allow you to move freely while wearing the printer.

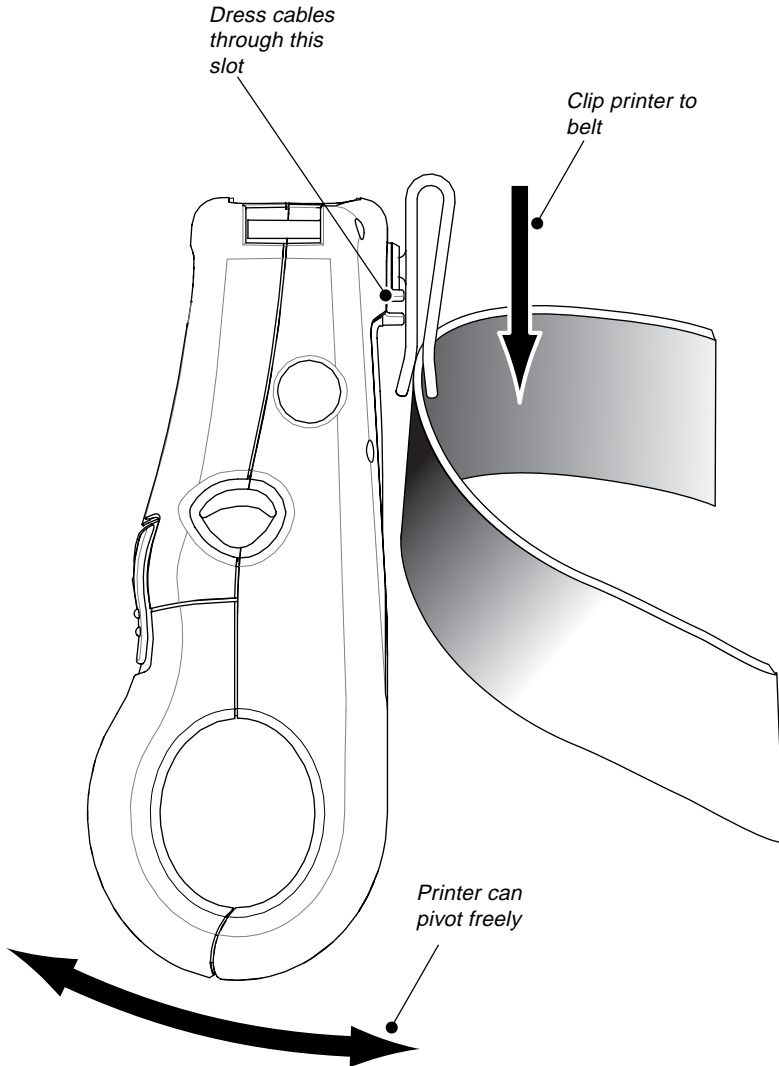

FIGURE 15



**WARNING:** *To avoid possible personal injury or damage to the printer, never insert any pointed or sharp objects into the printer.*

## Extending Battery Life

- Never expose the battery to direct sunlight or temperatures over 104° F (40° C).
- Always use a Zebra charger designed specifically for Lithium-Ion batteries. Use of any other kind of charger may damage the battery.
- Choose the media that is easiest to “burn.” An authorized Zebra re-seller can help you determine the optimum media for your application.
- If you print the same text or graphic on every label, consider using a pre-printed label.
- Choose the correct print darkness, and print speed for your media.
- Use software handshaking (XON/XOFF) whenever possible.
- Select Tear-Off mode whenever possible (Peel-Off mode uses more power).
- If your printer has the optional LCD display: Use the display backlight only when necessary. Turn it off whenever it is not needed. The LCD backlight consumes a great deal of power.
- Pull the battery out of the printer if the printer won't be used for a day or more and you're not performing a maintenance charge.
- Consider purchasing an extra battery.
- Remember that any rechargeable battery will lose its ability to maintain a charge over time. It can only be recharged a finite number of times before it must be replaced.

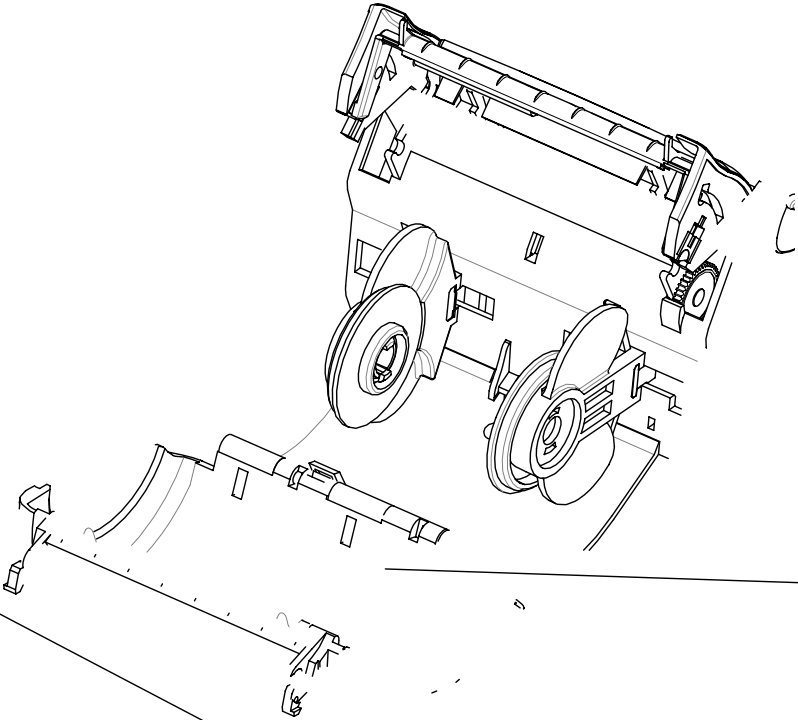

# Cleaning



**CAUTION.- Use only the cleaning agents indicated. Zebra Technologies Corporation will not be responsible for damage caused by any other cleaning materials used on this printer.**

**Never use any sharp objects on the printer mechanism as it could damage the print head. Use only the cleaning pen supplied with the printer or a cotton swab saturated with alcohol for cleaning the printer.**

Area	Method	Interval
Printhead (Figure 16)	Use the supplied cleaning pen or 70% isopropyl alcohol on a cotton swab to clean the print elements from end to end (the print elements are located in the thin gray line on the printhead). <i>If print quality has not improved after performing this procedure, try cleaning the printhead with a Cleaning Pad. This specially prepared material removes contamination buildup without damaging the printhead. Refer to Appendix C for more information.</i>	After every five rolls of media (or more often, if needed) Linerless media requires more frequent cleaning.
Platen Roller (Figure 16)	Rotate the platen roller and clean it thoroughly with the cleaning pen or 70% isopropyl alcohol and a cotton swab. Units with linerless platens: No cleaning is necessary. <i>Do not use alcohol on linerless platens!</i>	
Peel bar (Figure 16)	Clean thoroughly with the cleaning pen or 70% isopropyl alcohol and a cotton swab.	As needed
Tear bar (Figure 16)	Clean thoroughly with the cleaning pen or 70% isopropyl alcohol and a cotton swab.	
Exterior	Water-dampened cloth	
Interior (Figure 16)	Brush/air blow. Insure the Bar Sensor, Gap Sensor and Label Present Sensor windows are free of dust.	

# Troubleshooting





## Standard Control Panel

If the printer is not functioning properly, refer to the chart below to find the state of the two LEDs on the Control Panel. Then refer to the Troubleshooting topic referenced in the chart to resolve the problem.

Green LED	Yellow LED	Indication	Ref. to Topic
Steady	Off	Normal Operation, and/or RF Link established	n/a
Off	Off	Power Off	1
Fast Blink	Off	No RF Link	6, 11
Slow Blink	Off	Low Battery	3, 6, 7
Steady	Steady	Out of media, or Media Cover not closed	9, 11
Steady	Fast Blink	Normal RF activity	8
Steady	Fast Blink, Beeper Sounds	No application	8

## Optional LCD Control Panel

The top of the display shows several icons which indicate various printer functions. Check the indicator status, then refer to the Troubleshooting topic referenced in the chart to resolve the problem.

Status Icon	Condition	Indication	Ref. to Topic
	Steady	RF Link established	n/a
	Off	No RF Link	6
	Flashing	Low Battery	3, 6, 7
	Flashing	Head latch not closed	9, 11
	Flashing	Printer is receiving a file	8
	Flashing	Out of media,	9, 11
Blank Screen	n/a	No application	1,13



# Troubleshooting Topics

## 1. *No power*

- Check that battery is installed properly
- Recharge or replace battery as necessary.

## 2. *Media does not feed:*

- Be sure print head is closed and latched.
- Check spindle holding media for any binding.
- If unit is equipped with label presence sensor: Insure most recently printed label is removed. Also insure label sensor is not blocked.

## 3. *Poor or faded print or flashing:*

- Clean print head.
- Check battery and recharge or replace as necessary
- Check quality of media.

## 4. *Partial/missing print:*

- Check media alignment
- Clean print head.
- Insure printhead is properly closed and latched.

## 5. *Garbled print:*

- Check baud rate.

## 6. *No print:*

- Check baud rate
- Replace battery
- Check cable to terminal
- Establish RF Link (Wireless units only) or restore LAN associativity (QL 320N models only)
- Invalid label format or command structure — put printer in Communications Diagnostic (Hex Dump) Mode to diagnose problem.

## 7. *Reduced battery life*

- Check battery date code — if battery is one to two years old, short life may be due to normal aging.
- Recondition battery.
- Replace battery.

## 8. *Yellow error light or flashing:*

- No application or application corrupted: reload program.
- If using wireless communications: flashing indicator is normal while data is being transmitted or received.

*continued on next page*

**9. Yellow error light always on,  or  flashing:**

- Check media is loaded and print head is closed and securely latched.

**10. Skips labels:**

- Check media for top of form sense mark or label gap.
- Check that the maximum print field has not been exceeded on label.
- Insure bar/ or gap sensor is not blocked or malfunctioning

**11. Communication Error:**

- Check media is loaded, head is closed and error light is off.
- Check baud rate.
- Replace cable to terminal.

**12. Label Jam:**

- Open head release latch and media cover.
- Generously apply alcohol to printer in area of jammed label.

**13. Blank LCD Screen (only for units with optional LCD control panel)**

- No application loaded or application corrupted: reload program.

## Troubleshooting Tests

### Printing a Configuration Label

To print out a listing of the printer's current configuration follow these steps:

1. Turn the printer off. Load the media compartment with journal media (media with no black bars printed on the back)
2. Press and hold the Feed Button.
3. Press and release the Power button and keep the Feed button pressed. When printing starts, release the Feed button.

The printer will generate a configuration label as shown on Figures 17 and 17a :



# Sample Configuration Label (continued)

```

Low-bat Warning :0.00(178)
Low-bat Shut-down:6.55(168)
Memory(3):
Flash :1048575 Bytes
RAM :1048575 Bytes
Label:
Width :376 dots, 47 mm
Height:17310 dots, 2164 mm
Sensors: (Adj)
Pres[DAC:127,Thr:120,Cur: 10]
Label Present
Media [Cur:299]
Gap [DAC: 3,Thr: 40,Cur:143]
Bar [DAC:175,Thr: 80,Cur: 12]
Temperature :167
Voltage :8.07(287)
Resident Fonts:
Font      Sizes Chars
-----
0         0- 6 20-FF
1         0      20-00
2         0- 1 20-59
4         0- 7 20-FF
5         0- 3 20-FF
6         0      20-44
7         0- 1 20-FF
(ARI14BPT.CPF) 0
File Directory:
File      Size
-----
APPL .BIN 248886
CONFIG .SYS  89
ARI14BPT.CPF 6805
RLN .BAT  190
770000 Bytes Free
Command Language:
CCL key '['[21]

End of report.

Press FEED key to
enter DUMP mode.

Dump mode not entered.
    
```

Flash Memory Size

Maximum Label Size

Resident Fonts

Pre-scaled font (.cpf) listed separately

Files Loaded in Printer Memory (will include Pre-scaled or Scalable Fonts)

Amount of Memory Available

Instructions on entering Communications Diagnostics (Dump) Mode.

FIGURE 17A

## Communications Diagnostics

If there's a problem transferring data between the computer and the printer, try putting the printer in the Communications Diagnostics Mode (also referred to as the "DUMP" mode). The printer will print the ASCII characters and their and their text representation (or the period '.', if not a printable character) for any data received from the host computer

To enter Communications Diagnostics Mode:

1. Print a configuration label as described on pg. 34.
5. At the end of 2nd diagnostics report, the printer will print: "Press FEED key to enter DUMP mode".
6. Press the FEED key. The printer will print: "Entering DUMP mode".

**Note:** *If the FEED key is not pressed within 3 seconds, the printer will print "DUMP mode not entered" and will resume normal operation.*

7. At this point, the printer is in DUMP mode and will print the ASCII hex codes of any data sent to it, and their text representation (or "." if not a printable character).

Additionally, a file with a ".dmp" extension containing the ASCII information will be created and stored in the printer's memory. It can be viewed, "cloned" or deleted using the Label Vista application. (Refer the Label Vista documentation for more information.)

To terminate the Communications Diagnostics Mode and return the printer to normal operations:

1. Turn the printer OFF.
2. Wait 5 seconds.
3. Turn the printer ON.

## Calling the Help Desk

If the printer fails to print the configuration label, or you encounter problems not covered in the Troubleshooting Guide, contact the Help Desk. Help Desk addresses and phone numbers for your area can be found in Appendix D of this manual. The Help Desk will need the following information:

- Model number/type (e.g. QL 320)
- Unit serial number (Found on the large label on the back of the printer, also found in the configuration label printout))
- Product Configuration Code (PCC) (15 digit number found on the small label on the back of the unit)

# Specifications



**NOTE.- Printer specifications are subject to change without notice.**

## Printing Specifications

Print Density	203 dots/inch (8 dots/mm)
Print Width	Up to 2.9" (71.2 mm)
Print Speed	4" per second (101.6 mm per second)
Print Head Life, calculated	1,964,160" (50 Km) nominal
Distance from Print Element to Top of Form	.571" (14.5 mm) 116 dots

## Memory/Communications Specifications

Flash Memory	1 MB flash (standard); 2MB flash (optional)
SRAM Memory	1MB SRAM (standard); 2 MB SRAM (optional)
Standard Communications	RS-232 serial port (8 Pin circular DIN connector) Configurable Baud rate (from 9600 to 57.6 Kbps), parity and data bits. Software (X-ON/X-OFF) or hardware (DTR/STR) communication handshake protocols.
Optional Wireless Communications	Infrared wireless link (meets IrDA 1.1 communications specifications) 2,400 to 115,200 Baud rate  Bluetooth compatible 2.4 GHz SRRF link  Optional SRRF frequencies of 916 MHz and 2.4 GHz per Zebra proprietary wireless protocol.  Optional wireless LAN capabilities comply with 802.11 and 802.11b protocols

# Label Specifications

Label/Tag Width	1.5" to 3.1" (38.1 mm to 78.4 mm)
Max. Label/Tag Length	16" (406.4 mm) with standard memory
Inter-label Gap.	.08" to .16" (.12" preferred) 2 mm to 4 mm (3 mm preferred)
Label/Tag Thickness	.0025" to .0065" (.064 mm to .165 mm)
Label Roll Size: Max. Diameter	2.625" (66.7 mm) O.D.
Inner Core Diameter	.75" (19 mm) std, 1.38" (35.05 mm) optional Use Zebra-brand direct thermal media that is outside wound. Media may be reflective (black mark) sensing or transmissive (gap) sensing, die-cut, continuous or linerless. For die-cut labels, use only full auto dies.
Media Requirements	The reflective media black marks should extend past the centerline of the roll. <b>Minimum Black Mark Dimensions:</b> Mark width: 0.5" (12.7mm) perpendicular to the edge of the media, centered within the width of the roll. Mark length: 0.094" (2.4 mm) parallel to the edge of the media.

# Font/Bar Code Specifications

Fonts Available	Five resident scalable and rotatable fonts available from 12-48 pt. Downloadable pre-scaled fonts via Label Vista™ software Optional international character sets
1D Bar Codes Available	Codabar UCC/EAN 128 Code 39 Code 93 EAN 8/JAN 8, 2 and 5 digit extensions EAN 13/JAN 13, 2 and 5 digit extensions Interleaved 2 of 5 MSI/Plessey FIM/POSTNET UPC-A, 2 and 5 digit extensions UPC E, 2 and 5 digit extensions
2D Bar Codes Available	MaxiCode PDF 417
Rotation Angles	0°, 90°, 180°, and 270°

# Physical/Environmental/Electrical Specifications

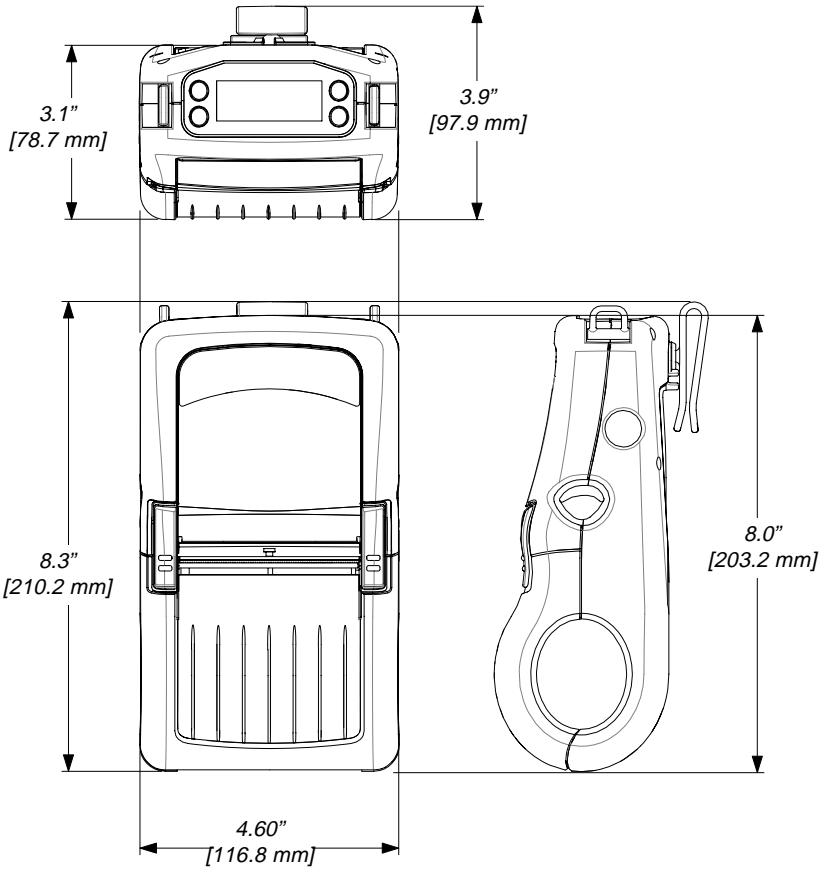

FIGURE 18 OVERALL DIMENSIONS

Weight w/ battery excluding media.	1.65 lbs. (.75 kg.)
Temperature Operating Storage	5° to 122° F (-15° to 50° C) -13° to 158° F (-25° to 70° C) Range
Relative Humidity Operation Storage	10% to 80% (non-condensing) 10% to 90% (non-condensing)
Electrical	Battery: 7.4V Lithium-Ion Charger: External battery charger, 120-230 VAC depending on model selected.



# Communications Port

Pin#	Signal Name	Type	Description
1	RXD	input	Receive Data
2	TXD	output	Transmit Data
3	CTS	input	Clear To Send from host
4	RTS	output	Request To Send
			set high when printer is ready to accept command /data
5	GND		Ground
6	NC		No Connect
7	DSR	input	Data Set Ready low to high transition turns printer on, high to low transition turns printer off (if enabled)
8	DTR	output	Data Terminal Ready set high when printer is on (set to battery voltage for "S" versions)

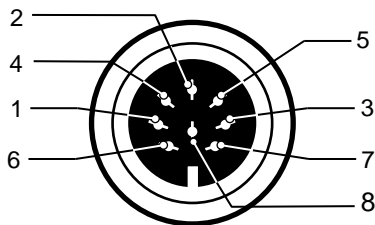

FIGURE 19 COMMUNICATIONS PORT  
(8 pin Circular DIN)

## **Agency Approvals**

- FCC Part 15 Subpart B Class A Electromagnetic Radiation Standard
- Built to UL, CUL and TUV standards
- EN50082-1 International Immunity Standard
- EN55022 Class B European Electromagnetic Radiation Standard

## **Accessories**

- Adjustable shoulder strap
- Protective soft case
- Extra battery packs
- 120-230 VAC battery charger
- Desk Mount
- Data cables

For details, call your authorized Zebra re-seller.

# Appendix A

## Interface Cables

Part Number BL11757-000; 8-Pin DIN to 9-Pin DB PC Cable

This part is also available as a coiled cable under Part Number BL15063-1.

For Use With a Personal Computer

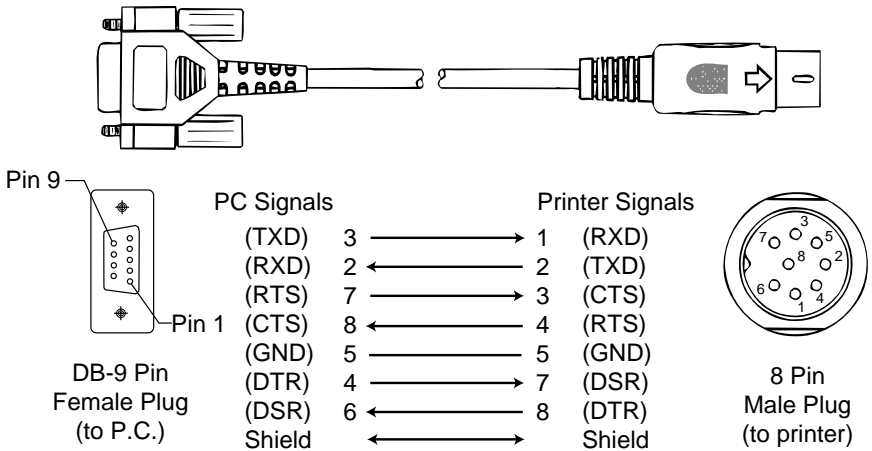

# Appendix A

## INTERFACE CABLES

Terminal	Cable Part Number	Cord Lgth/Type	Terminal Connector	Printer Connector	Notes
<b>COMPSEE</b>					
Apex II	BL12093-3	8' Coiled	RJ45	8 Pin DIN	
<b>LXE</b>					
MX1, MX3	BL17757-000	6'/Straight	9 Pin DB	8 Pin DIN	
1380, 1390, 1590	BL17757-000	6'/Straight	9 Pin DB	8 Pin DIN	
2325	BL12093-1	8'/Coiled	RJ45	8 Pin DIN	Power On/Off (+5V)
<b>NORAND</b>					
RT1100/1700 Series	BL11537-1	8'/Coiled	6 Pin MiniDIN	8 Pin DIN Over-molded	
RT1100/1700 Series	BL11537-2	12'/Coiled	6 Pin MiniDIN	8 Pin DIN Over-molded	
RT5900 Series	BL12803-1	8'/Coiled	15 Pin D-Sub	8 Pin DIN	
RT1100/1700 Series	BL12804-1	8'/Coiled	6 Pin MiniDIN	8 Pin DIN - Locking	
RT1100/1700 Series	BL13298-1	8'/Coiled	6 Pin MiniDIN	8 Pin DIN Over-molded	Auto ON/OFF
RT1100/1700 Series	BL13309-1	8'/Coiled	6 Pin Mini DIN	8Pin DIN	Auto ON/OFF
6400	BL11757-000	6'/Straight	9 Pin DB	8 Pin DIN	
<b>SYMBOL</b>					
PDT3300 Series	BL11391-000	8'/Coiled	DB25 male	8 Pin DIN	Must be used with Symbol RS232
PDT4100 Series	BL11757-000	6'/Straight	9 Pin DB Fem.	8 Pin DIN	Adapter - Symbol P/N#25-12059-01
PDT3100/3500 /6100 Series	BL12093-1	8'/Coiled	RJ45	8 Pin DIN	a. Power On/Off (+5V) b. Used for the Percon Falcon
PDT3100 Series	BL12093-2	8'/Coiled	RJ45	8 Pin DIN	Power On/Off (DTR Line)

# Appendix A

## INTERFACE CABLES (continued)

Terminal	Cable Part Number	Cord Lgth/Type	Terminal Connector	Printer Connector	Notes
<b>SYMBOL (CONT.)</b>					
SPT1700 Series	BL15483-1	9'/Coiled	Cradle	8 Pin DIN	No Power On/Off (DTR Line)
SPT2700 Series	BL15482-1	9'/Coiled	Cradle	8 Pin DIN	Power On/Off (DTR Line)
LRT/LDT3800 Series	CC11371-3	6'/Coiled	PIM Optical	8 Pin DIN	"S" Printers Only
LRT/LDT3800 Series (2 Way)	CC11371-14	6' / Coiled	PIM Optical	8 Pin DIN	"S" Printers Only
LRT/LDT3800 & 6800 Series	CC11371-14	6' / Coiled	PIM Optical	8 Pin DIN	"S" Printers Only
LRT/LDT3800 & 6800 Series	CC11371-15	6' / Coiled	PIM Optical	8 Pin DIN	"S" Printers Only
<b>TEKLOGIC</b>					
7030 ILR	BL13285-2	Coiled	36 Pin IDC Fem	8 Pin DIN	
7025 ILR	BL13285-1	Coiled	15 Pin DB male	8 Pin DIN	
<b>TELXON</b>					
960	BL11122-1	8'/Coiled	RJ45	8 Pin DIN	
960SL Adapter for BL11122-1	CC13711-1	n/a	n/a	n/a	
960 (BL11122-1) & 960SL (CC13711-1)	CP74005	n/a	n/a	n/a	
960	BL12996-1	8'/Coiled	RJ45	8 Pin DIN-Locking	
860 & 912	CL11314-000	8'/Coiled	DB25	8 Pin DIN	

## Media Supplies

To insure maximum printer life and consistent print quality and performance for your individual application, it is recommended that only media produced by Zebra be used. These advantages include:

- Consistent quality and reliability of media products.
- Large range of stocked and standard formats.
- In-house custom format design service.
- Large production capacity which services the needs of many large and small media consumers including major retail chains world wide.
- Media products that meet or exceed industry standards.

For more information call Zebra Technologies Corporation at +1.401.739.5800 and ask to speak to a Media Sales Representative.

## Maintenance Supplies

In addition to using quality media provided by Zebra, it is recommended that the printer be cleaned as prescribed in the maintenance section. The following items are available for this purpose:

- Cleaning Pen (10 pack), Reorder No. AN11209-1
- Cleaning Kit with Cleaning Pen, and Cotton Swabs, Reorder No. AT702-1

## Product Support

When calling with a specific problem regarding your printer, please have the following information on hand:

- Model number/type (e.g. QL 320)
- Unit serial number (Found on the large label on the back of the printer)
- Product Configuration Code (PCC) (15 digit number found on the small label on the back of the unit)

Contact the Help Desk at:

Zebra Technologies Corporation  
30 Plan Way  
Warwick, Rhode Island 02886-1012 USA  
Telephone: +1 401.739.5800  
Fax: +1 401.732.7808  
e-mail: [risupport@zebra.com](mailto:risupport@zebra.com)

In Europe:

Zebra Technologies Europe, Limited  
Zebra House  
The Valley Centre, Gordon Road  
High Wycombe  
Buckinghamshire HP13 6EQ, United Kingdom  
Telephone: +44 1494 768298  
Fax: +44 1494 768210  
e-mail: [tseurope@zebra.com](mailto:tseurope@zebra.com)  
Ask for Customer Support



# Index

- A
- Accessories 42
- Agency Approvals 42
- B
- Battery, charging 9
  - while printing 9
- Battery, installing 9
- Battery life, tips 29
- Belt clip 25, 28
- Bluetooth Device Address (BDA). *See* Communications: short range radio frequency (SRRF): Bluetooth™
- C
- Charger, battery 9
- Cleaning
  - Exterior 31
  - Interior 31
  - Linerless platen roller 31
  - Peel bar 31
  - Platen roller 31
  - Printhead 31
  - Sensors 31
  - Tear bar 31
- Communications
  - Connector signals 41
  - infrared (IR) 20
  - SRRF 21
    - Bluetooth™ 23
    - Zebra proprietary protocol 21
  - with a cable 19
- Communications diagnostics 37
- Configuration label 34
  - sample printout 35, 36
- D
- Damage, shipping 7
- H
- Help Desk, contacting 37
- L
- Label Vista 17, 26
  - use in troubleshooting 37
- LAN. *See* Wireless communication: Local Area Network
- M
- Manual
  - CPL Programming 7, 26
  - ZPL II Programming 7, 26
- Media, loading 10
  - adjusting for core diameter 11
  - peel-off mode 12
  - tear-off mode 12
- O
- Operator Controls 13
  - LCD Keypad 15
    - functions displayed 17
  - Standard Keypad 13



# Patent Information

This product and/or its use may be covered by one or more of the following US patents and corresponding international patents worldwide

D275,286	5,017,765	5,304,786	5,479,441	5,909,233
D347,021	5,021,641	5,304,788	5,486,057	5,976,720
D389,178	5,029,183	5,321,246	5,503,483	5,978,004
D430,199	5,047,617	5,335,170	5,504,322	5,995,128
D433,702	5,103,461	5,364,133	5,528,621	5,997,193
3,964,673	5,113,445	5,367,151	5,532,469	6,004,053
4,019,676	5,140,144	5,372,439	5,543,610	6,010,257
4,044,946	5,132,709	5,373,148	5,545,889	6,020,906
4,360,798	5,142,550	5,378,882	5,552,592	6,034,708
4,369,361	5,149,950	5,396,053	5,570,123	6,036,383
4,387,297	5,157,687	5,396,055	5,578,810	6,057,870
4,460,120	5,168,148	5,399,846	5,589,680	6,068,415
4,496,831	5,168,149	5,408,081	5,612,531	6,070,805
4,593,186	5,180,904	5,410,139	5,642,666	6,095,704
4,607,156	5,229,591	5,410,140	5,657,066	6,109,801
4,673,805	5,230,088	5,412,198	5,768,991	6,123,471
4,736,095	5,235,167	5,415,482	5,790,162	6,147,767
4,758,717	5,243,655	5,418,812	5,791,796	6,151,037
4,816,660	5,247,162	5,420,411	5,806,993	6,201,255B1
4,845,350	5,250,791	5,436,440	5,813,343	6,231,253B1
4,896,026	5,250,792	5,444,231	5,816,718	6,261,009
4,897,532	5,262,627	5,449,891	5,820,279	6,261,013
4,923,281	5,267,800	5,449,893	5,848,848	6,267,521
4,933,538	5,280,163	5,468,949	5,860,753	6,270,072B1
4,992,717	5,280,164	5,479,000	5,872,585	6,285,845B1
5,015,833	5,280,498	5,479,002	5,874,980	6,292,595
				6,296,032



## **Zebra Technologies Corporation**

Mobile Printer Center of Excellence

30 Plan Way

Warwick, RI 02886.1012 U.S.A.

Telephone: +1 401.739.5800

+ 1 800.556.7266

Facsimile: +1 401.732.7808

## **Zebra Technologies Europe Limited**

Zebra House

The Valley Centre, Gordon Road

High Wycombe

Buckinghamshire HP13 6EQ, UK

Telephone: +44 (0) 1494 472872

Facsimile: +44 (0) 1494 450103

*visit our website at [www.zebra.com](http://www.zebra.com)*

