

Instruction Manual

P/N 3100572, Rev. E

March 2004

Micro Motion[®] Model IFT9701 Transmitter with Optional Display

Instruction Manual



Micro Motion[®]

Model IFT9701 Transmitter with Optional Display

Instruction Manual

For online technical support, refer to the EXPERT₂[™] tool at www.expert2.com. To speak to a customer service representative, call the support center nearest you:

- In U.S.A., phone 1-800-522-MASS (1-800-522-6277)
- In Canada and Latin America, phone (303) 530-8400
- In Asia, phone (65) 6770-8155
- In the U.K., phone 0800 - 966 180 (toll-free)
- Outside the U.K., phone +31 (0) 318 495 670

Contents

Chapter 1	Before You Begin	1
1.1	About this manual	1
1.2	Safety	1
1.3	European installations	2
1.4	Definitions	2
1.5	Flowmeter components	2
Chapter 2	Getting Started	5
2.1	Safety, reliability, accessibility	5
2.1.1	Hazardous area	5
2.1.2	Orientation and mounting	6
2.1.3	Temperature, humidity, and vibration	6
2.1.4	Visibility of tags	7
2.2	Transmitters approved for ATEX Zone 1	7
2.3	Jumper settings	8
2.3.1	Security	9
2.3.2	Fault output levels	9
2.3.3	Re-installing the circuit board compartment cover	10
Chapter 3	Remotely Mounting the Transmitter	11
3.1	Overview	11
3.2	Choosing the proper location	11
3.3	Mounting the transmitter	11
3.3.1	Guidelines for flat-surface mounting	11
3.3.2	Guidelines for pole mounting	11
3.4	Connecting the transmitter to the sensor	14
3.4.1	Cable types	14
3.4.2	Guidelines for conduit	16
3.4.3	Guidelines for cable gland	16
3.4.4	Wiring connections to sensor	16
Chapter 4	Power Supply and Output Wiring	19
4.1	Overview	19
4.2	Wiring guidelines	19
4.3	Connect power supply wiring	20
4.4	Connect output wiring	21
4.4.1	Milliamp output	22
4.4.2	Milliamp output connected to Bell 202 multidrop network	23
4.4.3	Communication tools connected to milliamp output	24
4.4.4	Pulse output	25

Chapter 5	Flowmeter Startup	29
5.1	Overview	29
5.2	Customer service	29
5.3	Startup procedures	29
5.4	Initialization	30
5.4.1	Diagnostic LED	30
5.4.2	Optional display	30
5.4.3	Startup mode	30
5.4.4	Operating mode	30
5.5	Flowmeter zeroing	31
5.5.1	Zeroing procedure	31
5.5.2	Diagnosing zero failure	32
5.6	Configuration, calibration, and characterization	32
5.7	Process measurement	33
Chapter 6	Configuration with a HART Communicator	35
6.1	Configuration overview	35
6.2	Configuration parameters	36
6.2.1	HART tag	36
6.2.2	Measurement units	36
6.2.3	Flow cutoff	38
6.2.4	Damping	38
6.2.5	Flow direction	39
6.2.6	Range values for milliamp output	40
6.2.7	Pulse output scaling	40
6.3	Calibration procedures	41
6.3.1	Auto zero	41
6.3.2	Flow calibration procedure	42
6.4	Characterization	44
Chapter 7	Configuration with ProLink II Software	45
7.1	Configuration overview	45
7.2	Configuration parameters	46
7.2.1	HART tag	46
7.2.2	Process variable measurement	47
7.2.3	Output configuration	50
7.3	Calibration procedures	51
7.3.1	Auto zero	51
7.3.2	Flow calibration procedure	53
7.4	Characterization	55
Chapter 8	Troubleshooting	57
8.1	Customer service	57
8.2	General guidelines	57
8.3	Transmitter diagnostic tools	57
8.3.1	Diagnostic LED	57
8.3.2	Optional LCD	58
8.3.3	Fault outputs	58
8.4	Power supply	59
8.5	Wiring	60
8.6	Over range and sensor failure conditions	61

Contents *continued*

8.7	Slug flow	62
8.8	Transmitter failure	63
8.9	Digital diagnostic messages	63

Appendix A IFT9701 Specifications 65

A.1	Performance specifications	65
A.2	Functional specifications	65
A.2.1	Output signals	65
A.2.2	Local display (optional)	66
A.2.3	Low-flow cutoff	66
A.2.4	Slug-flow inhibit	66
A.2.5	Damping.	66
A.2.6	Fault indication	66
A.2.7	Output testing.	66
A.2.8	Power supply options	66
A.3	Environmental limits	67
A.3.1	Temperature	67
A.3.2	Process fluid temperature limits	67
A.3.3	Humidity limits	68
A.3.4	Vibration limits	68
A.4	Density limits	68
A.5	Environmental effects	68
A.6	Ambient temperature effect on milliamp output	69
A.7	Shipping weight	69
A.8	Hazardous area classifications	69

Appendix B HART Communicator Menu Trees 71

Appendix C Installing the Optional Display 73

Appendix D Return Policy 75

D.1	General guidelines	75
D.2	New and unused equipment	75
D.3	Used equipment	75

Index 77

Chapter 1

Before You Begin

1.1 About this manual

This instruction manual explains how to install, start up, configure, and troubleshoot the Micro Motion IFT9701 transmitter for use with Micro Motion Coriolis flow sensors. For more information about the sensor, see the appropriate sensor instruction manual.

1.2 Safety

Safety messages are provided throughout this manual to protect personnel and equipment. Read each safety message carefully before proceeding to the next step.

WARNING

Improper installation in a hazardous area can cause an explosion.

For information about hazardous applications, refer to Micro Motion ATEX, CSA, or UL installation instructions, shipped with the transmitter or available from the Micro Motion web site.

WARNING

Hazardous voltage can cause severe injury or death.

Make sure power is disconnected before installing transmitter.

CAUTION

Improper installation could cause measurement error or transmitter failure.

Follow all instructions to ensure transmitter will operate correctly.

1.3 European installations

This Micro Motion product complies with all applicable European directives when properly installed in accordance with the instructions in this manual. Refer to the EC declaration of conformity for directives that apply to this product.

The EC declaration of conformity, with all applicable European directives, and the complete *ATEX Installation Drawings and Instructions* are available on the internet at www.micromotion.com/atex or through your local Micro Motion support center.

1.4 Definitions

- The term “sensor” refers to a Micro Motion sensor only.
- The term “flowmeter” refers to an IFT9701 transmitter and a sensor installed as a flowmetering system.

1.5 Flowmeter components

The IFT9701 transmitter can be integrally mounted to a Micro Motion F-Series sensor, or remotely mounted from an ELITE®, F-Series, Model D, or Model DL sensor.

The IFT9701 transmitter does not operate with Micro Motion T-Series, R-Series, or Model D600 or DT sensors.

- If the transmitter is integrally mounted to the sensor, the flowmeter includes the components shown in Figure 1-1.
- If the transmitter will be remotely mounted from the sensor, the transmitter includes the components shown in Figure 1-2.

The transmitter is available with an optional liquid crystal display (LCD), as shown in Figure 1-1 and Figure 1-2, except for ATEX Zone 1 areas.

Figure 1-1 Integrally mounted IFT9701 transmitter with F-Series sensor

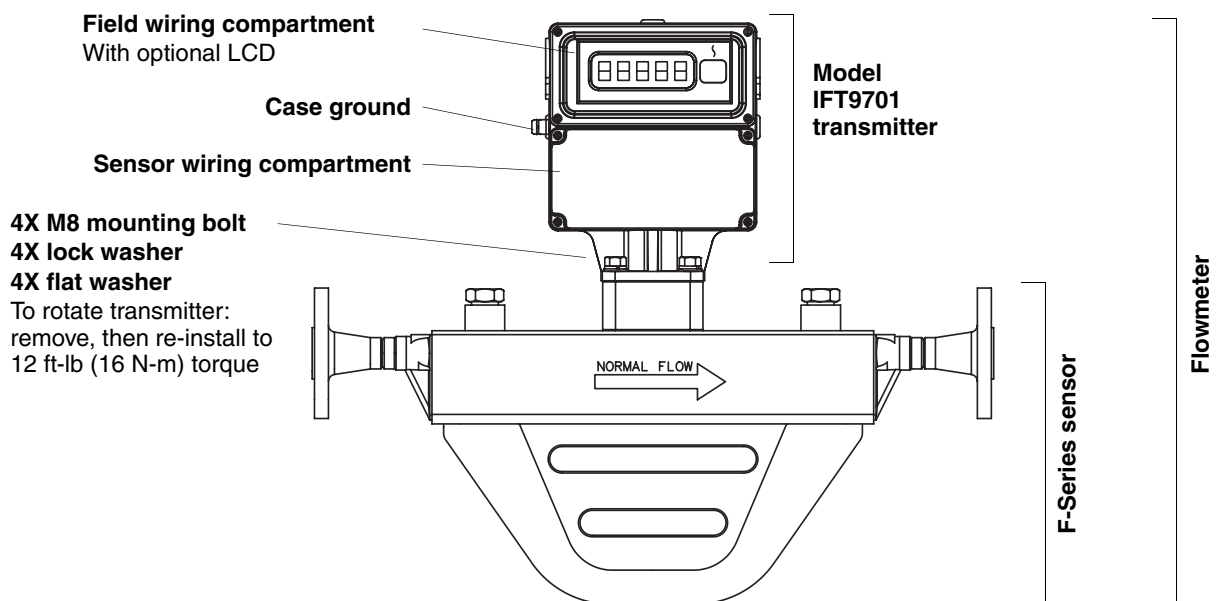
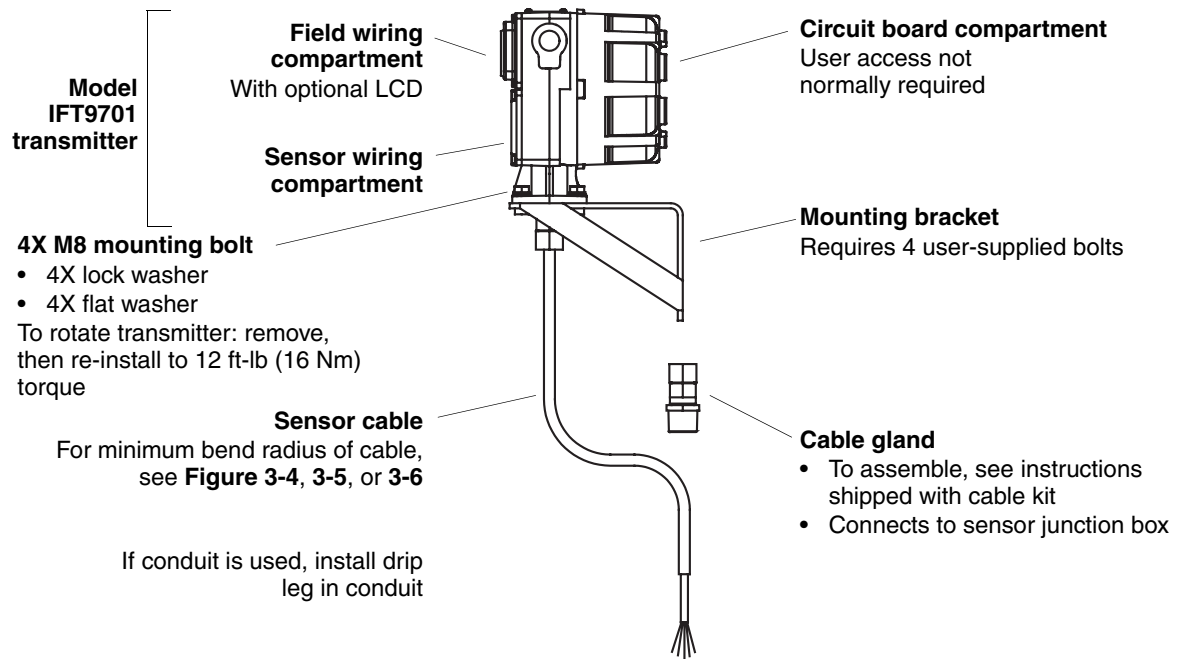

Figure 1-2 Remotely mounted IFT9701 transmitter



Chapter 2

Getting Started

2.1 Safety, reliability, accessibility

⚠ WARNING

Improper installation in a hazardous area could cause an explosion.

Install the transmitter in an environment that is compatible with the hazardous area specified on the approvals tag.

- For intrinsically safe sensor installations, use this document with Micro Motion ATEX, CSA, or UL installation instructions.
- For hazardous area installations in Europe, refer to standard EN 60079-14 if national standards do not apply.

2.1.1 Hazardous area

If you plan to mount the transmitter in a hazardous area, ensure that your equipment and installation meet the hazardous area requirements. For more information about hazardous area classifications, see Section A.8. See Figure 2-1 for the location of the approvals tag on your transmitter.

Figure 2-1 Location of approvals tag

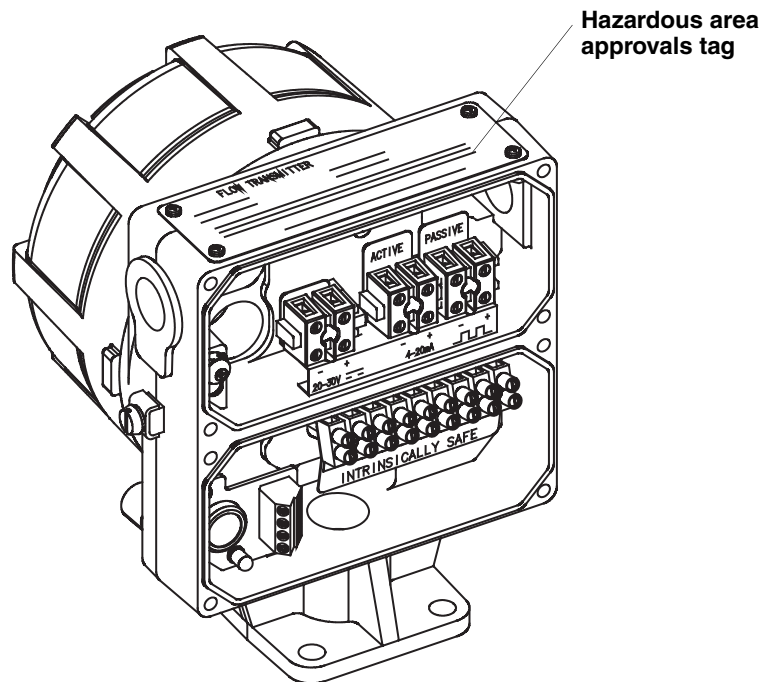

2.1.2 Orientation and mounting

Orient the transmitter so wiring compartments and conduit openings are easily accessible.

- To rotate the transmitter on the sensor manifold or the mounting bracket, use the four supplied mounting bolt assemblies. Each bolt assembly includes one M8 bolt, one lock washer, and one flat washer. Remove the bolt assemblies, rotate the transmitter, then reinstall the bolt assemblies to 12 ft-lb (16 N-m) of torque.
- If the transmitter will be integrally mounted to a Micro Motion F-Series sensor, see the sensor product data sheet for transmitter and sensor dimensions, and see the instruction manual that was shipped with the sensor for information about flowmeter mounting and location.
- If the transmitter will be remotely mounted, use the supplied bolt assemblies to attach the transmitter to the mounting bracket. Attach the bracket to a rigid, stable surface or instrument pole that will not transfer excessive vibration into the transmitter. See Chapter 3 for more information about remote mounting.

2.1.3 Temperature, humidity, and vibration

Install the transmitter according to specified limits:

- Ambient temperature
 - without optional LCD: -22 to +131 °F (-30 to +55 °C)
 - with optional LCD: 32 to 131 °F (0 to 55 °C)
- Humidity: 5 to 95% non-condensing
- Vibration: Meets IEC 68.2.6, 2 g

2.1.4 Visibility of tags

For personal and system safety, all tags attached to the transmitter housing must remain visible. Clean or replace them as necessary.

2.2 Transmitters approved for ATEX Zone 1

⚠ WARNING

Explosion hazard

The circuit board compartment is rated EEx d (flameproof), and should remain closed at all times after the flowmeter has been installed.

To avoid risk of explosion in an explosive atmosphere:

- Read label that points to compartment cover before accessing circuit board compartment. Figure 2-2 shows the location of the labels on the transmitter housing.
- Shut off power, and wait at least 2 minutes before removing EEx d (circuit board) compartment cover. Figure 2-2 also identifies the EEx e (field wiring), EEx i (sensor wiring), and EEx d (circuit board) compartments.

If the transmitter carries an ATEX Zone 1 approval, wiring compartments are labeled as shown in Figure 2-2.

- The sensor wiring compartment is rated EEx i (intrinsically safe), and may be opened at any time. See *Label 1* in Figure 2-2.
- The field wiring compartment is rated EEx e (increased safety), and should remain closed when power is on. See *Label 2* in Figure 2-2.
- The circuit board compartment is rated EEx d (flameproof), and should remain closed at all times after the transmitter has been installed. If the transmitter is approved by ATEX as flameproof, the compartment has a lockout device, shown in Figure 2-2. The lockout device must be loosened and rotated before the compartment cover can be unscrewed.

Figure 2-2 Compartment tags and lockout device

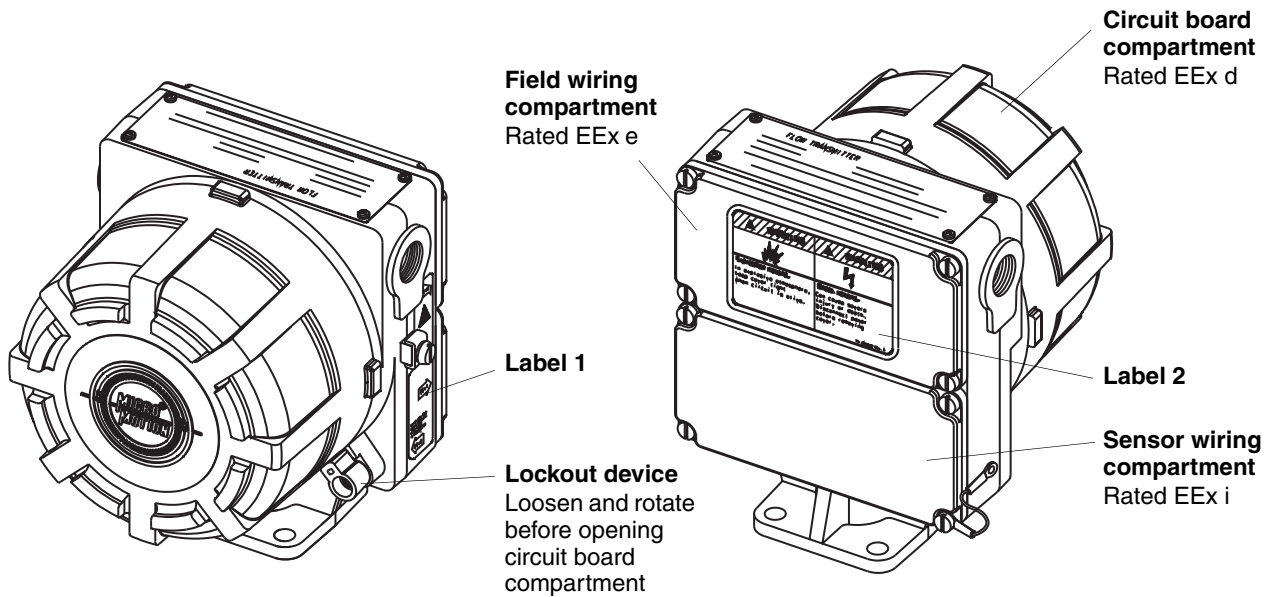

2.3 Jumper settings

Unless otherwise specified on the order, jumpers are set so the transmitter generates downscale fault outputs and enables flowmeter configuration. If jumper settings need to be changed, the procedure should be performed before the transmitter is installed.

- To access security and fault output jumpers, unscrew the circuit board compartment cover.
- If the transmitter is approved by ATEX as flameproof, the compartment has a lockout device. See Figure 2-2. The lockout device must be loosened and rotated before the compartment cover can be unscrewed.

⚠ CAUTION

Improper handling of transmitter components can damage the transmitter.

- If a breaker bar is used for loosening the cover of the circuit board compartment:
 - Apply steady pressure to avoid chipping the paint on the transmitter housing. Chipped paint can result in corrosion of the housing. If paint becomes chipped, repaint the housing.
 - Do not apply too much pressure. Excessive torque can damage the pipeline, transmitter, or sensor.
- To prevent electrostatic discharge, wear an anti-static wrist strap while setting jumpers.

2.3.1 Security

The security jumper enables the user to write-protect the flowmeter configuration, so it cannot be changed using a HART communication device:

- With the security jumper OFF, the flowmeter configuration can be changed.
- With the security jumper ON, the flowmeter configuration cannot be changed.

The default setting is OFF. To set the security jumper, see Figure 2-3.

2.3.2 Fault output levels

The transmitter can be configured to produce downscale or upscale fault outputs. In a fault condition:

- Downscale: The milliamp output goes to 2 mA; the pulse output goes to 0 Hz.
- Upscale: The milliamp output goes to 22 mA; the pulse output goes to 7200 Hz.
- The diagnostic LED blinks ON four times per second, whether the setting is upscale or downscale.

The default setting is downscale. To set the fault output jumper, see Figure 2-3.

Figure 2-3 Jumper location and settings

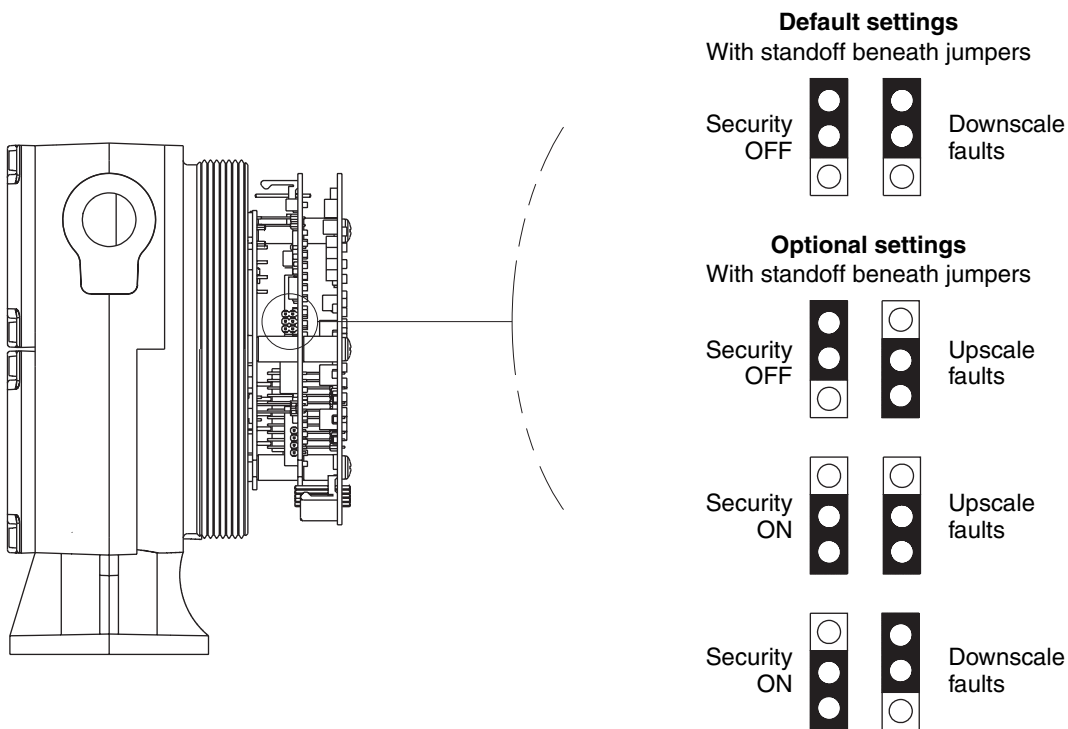

2.3.3 Re-installing the circuit board compartment cover

To re-install the cover of the circuit board compartment:

1. Screw the cover back onto the housing.
2. Hand-tighten the cover until it seats on the O-ring.
3. If the circuit board compartment has a lockout device, as shown in Figure 2-2, rotate the clamp into place and push it into the slot. Use a 4-mm (5/32-inch) Allen wrench to tighten the lockout screw to 5 inch-pounds (0,56 N-m) of torque.

Chapter 3

Remotely Mounting the Transmitter

Note: The instructions in this chapter apply only if the transmitter will be remotely mounted from the sensor. If the transmitter is integrally mounted to the sensor, proceed to Chapter 4.

3.1 Overview

To mount the transmitter remotely from the sensor, the following steps are required:

- Choosing the proper location (see Section 3.2)
- Mounting the sensor on a flat surface or instrument pole (see Section 3.3)
- Connecting the transmitter to the sensor (see Section 3.4)

3.2 Choosing the proper location

Install the transmitter according to the conditions stated in Section 2.1.

For mounting dimensions, see Figure 3-1.

Total length of cable from sensor to transmitter must not exceed 1000 feet (300 meters).

For bend radii of cables, see Figure 3-4, Figure 3-5, or Figure 3-6, according to the type of cable to be used.

3.3 Mounting the transmitter

A transmitter that is to be remotely mounted from the sensor is shipped with an L-shaped mounting bracket. Attach the bracket to a rigid, stable surface or instrument pole that will not transfer excessive vibration into the transmitter.

3.3.1 Guidelines for flat-surface mounting

- Use four 5/16-inch (M8) nuts (not included), suitable for the environment.
- Do not secure bolts to separate beams, girders, wall studs, etc., which can move independently.
- To prevent unnecessary stress on the mounting bracket, use washers to shim the bracket if the mounting surface is not flat.
- For more information, see Figure 3-2.

3.3.2 Guidelines for pole mounting

- Use two 5/16-inch (M8) U-bolts for 2-inch pipe, and four 5/16-inch (M8) nuts (not included), suitable for the environment.
- For more information, see Figure 3-3.

Figure 3-1 Installation dimensions for remote mounting

Dimensions in inches
(mm)

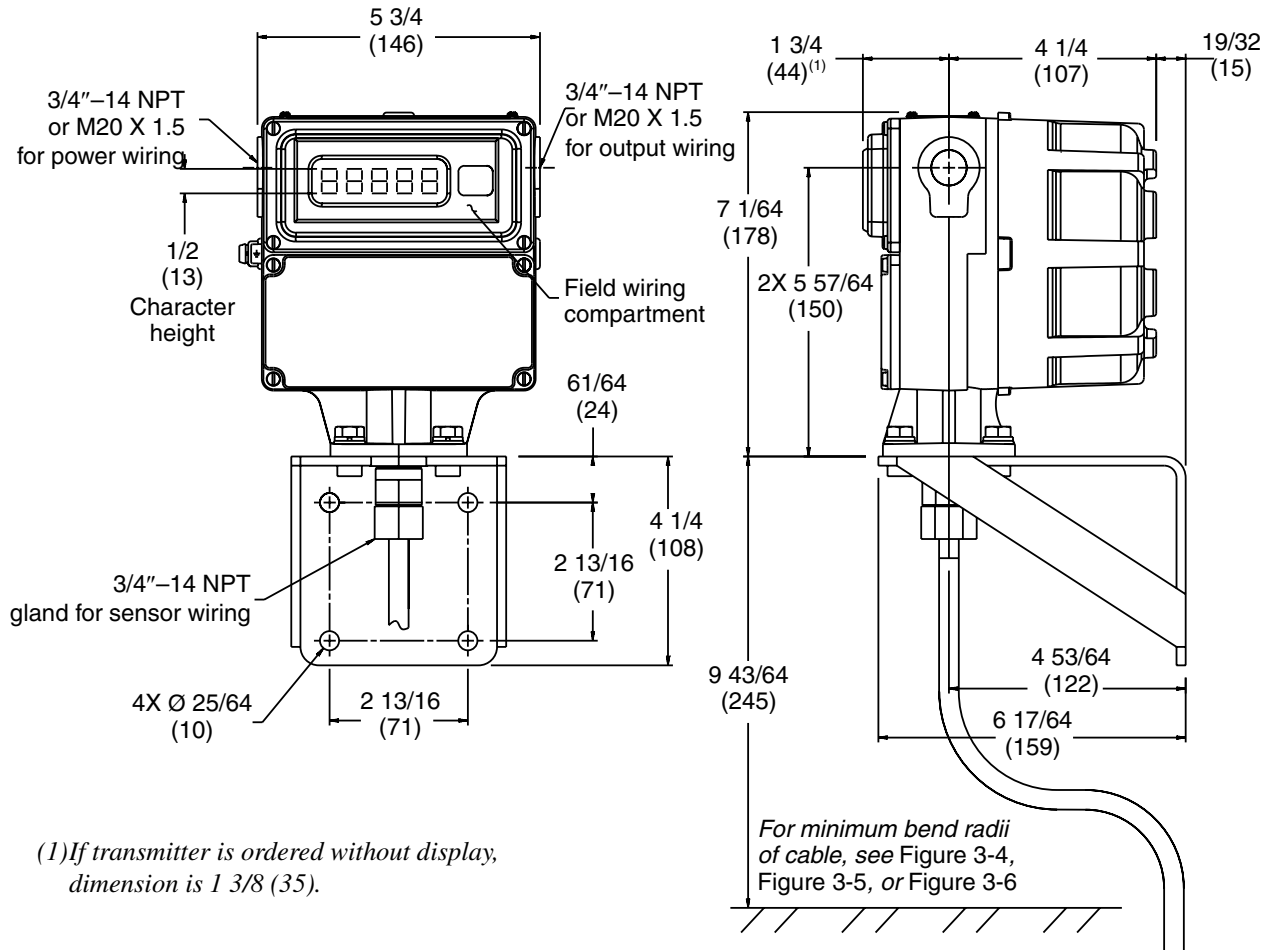

Figure 3-2 Mounting the transmitter to a wall or other surface

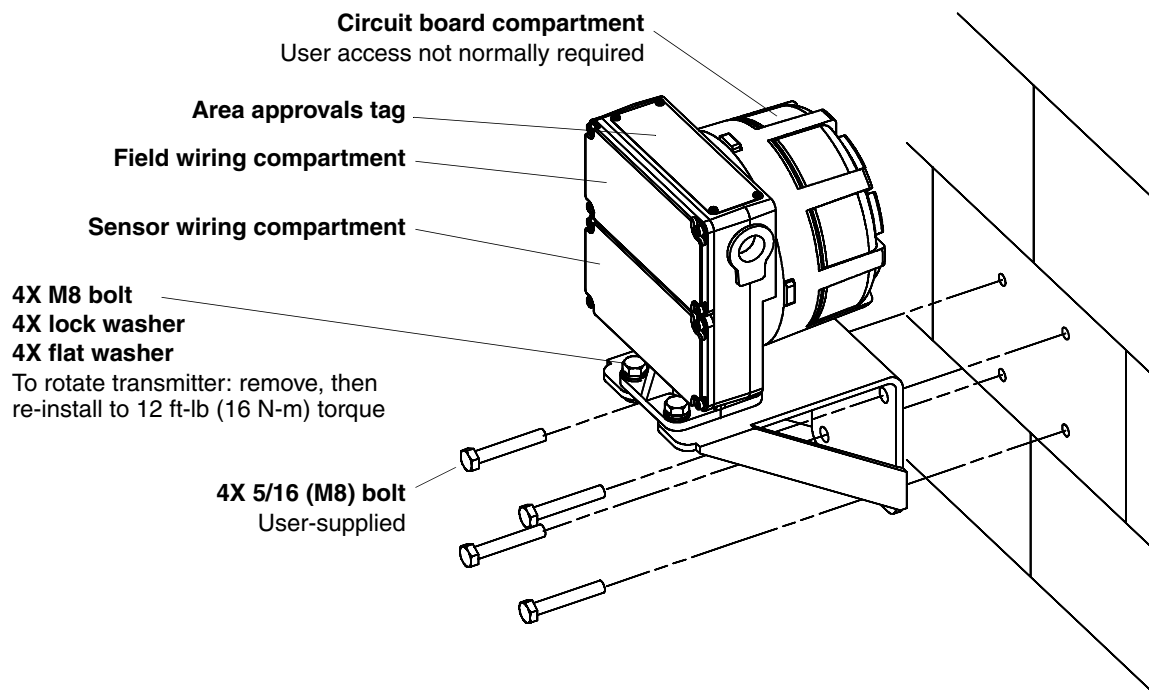
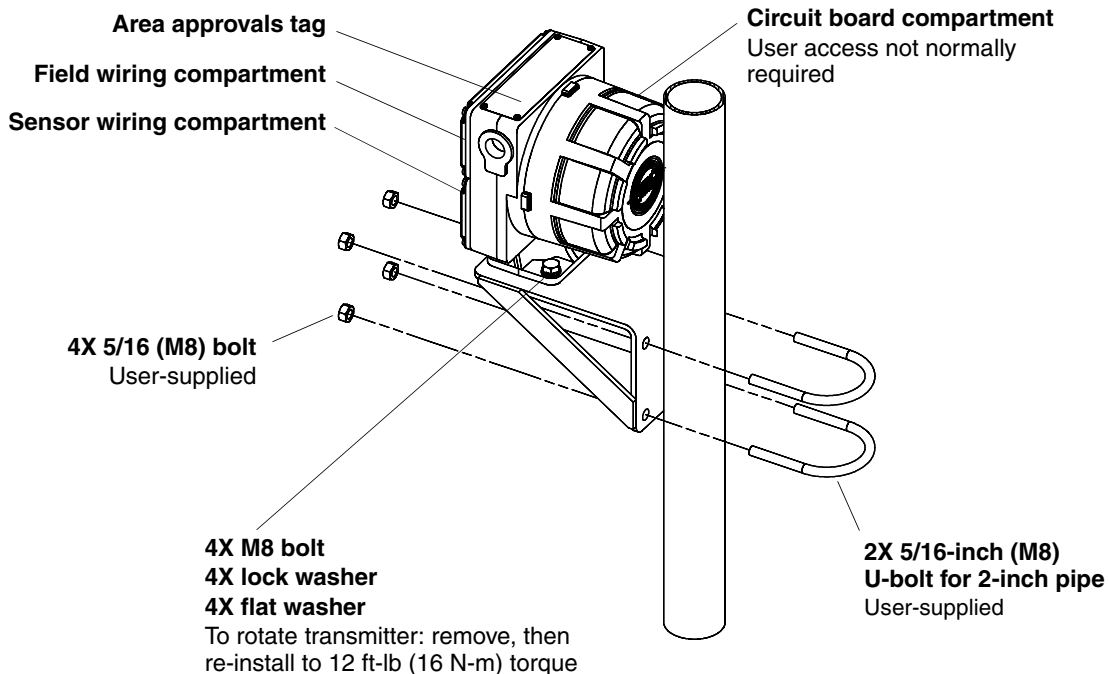

Figure 3-3 Mounting the transmitter to an instrument pole



3.4 Connecting the transmitter to the sensor

⚠ CAUTION

Improper installation of cable, cable gland, or conduit could cause inaccurate measurements or flowmeter failure.

To ensure 360° termination shielding for flowmeter wiring, install the factory-supplied cable gland or user-supplied sealed metallic conduit to the conduit opening on the sensor junction box.

To connect the transmitter to the sensor:

- Micro Motion 9-wire cable is required. See Section 3.4.1 for information on cable types offered by Micro Motion.
- Depending on your cable type, you must either install the cable in conduit or use cable glands. See Section 3.4.2 for information on conduit installations. See Section 3.4.3 for information on cable gland installations.
- For information on connecting the wires to the terminals, see Section 3.4.4.

Micro Motion’s *9-Wire Flowmeter Cable Preparation and Installation Guide*, shipped with the cable, provides additional information on cable types, cable preparation, and installation requirements.

3.4.1 Cable types

Micro Motion supplies 9-wire jacketed, shielded, or armored cable.

- Jacketed cable is CE-compliant when it is installed inside user-supplied sealed metallic conduit that provides 360° termination shielding for the enclosed cable. See Figure 3-4 for an illustration of jacketed cable.
- Shielded and armored cable are CE-compliant when the cable is installed with the factory-supplied cable glands. See Figure 3-5 for an illustration of shielded cable, and Figure 3-6 for an illustration of armored cable.
- Each cable type is available with a PVC or Teflon® FEP jacket. For temperature ranges of cable jacket materials, see Table 3-1.

See Table 3-2 for guidelines on cable selection. All cable types are acceptable for cable tray installation.

Figure 3-4 Jacketed cable

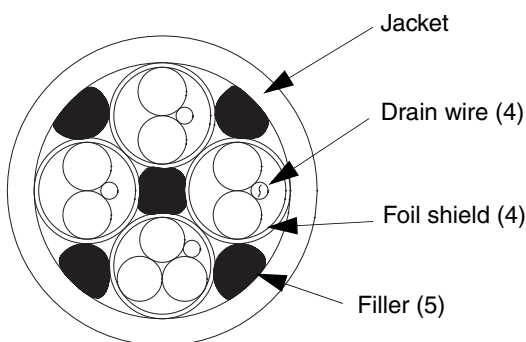

Jacket material	Outside diameter <i>inches (mm)</i>	Minimum bend radii	
		Static (no load) condition <i>inches (mm)</i>	Under dynamic load <i>inches (mm)</i>
PVC	0.415 (10)	3 1/8 (80)	6 1/4 (159)
Teflon® FEP	0.340 (9)	2 5/8 (67)	5 1/8 (131)

Figure 3-5 Shielded cable

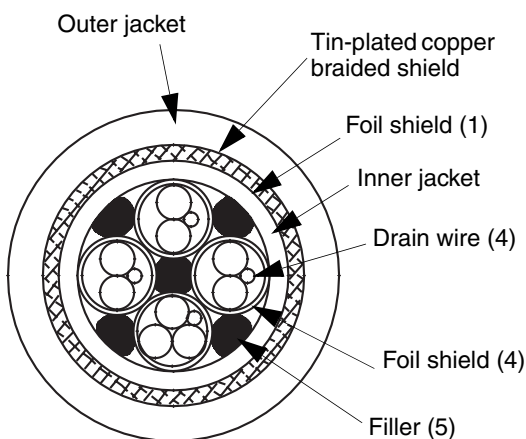

Jacket material	Outside diameter <i>inches (mm)</i>	Minimum bend radii	
		Static (no load) condition <i>inches (mm)</i>	Under dynamic load <i>inches (mm)</i>
PVC	0.525 (14)	4 1/4 (108)	8 1/2 (216)
Teflon® FEP	0.425 (11)	3 1/4 (83)	6 3/8 (162)

Figure 3-6 Armored cable

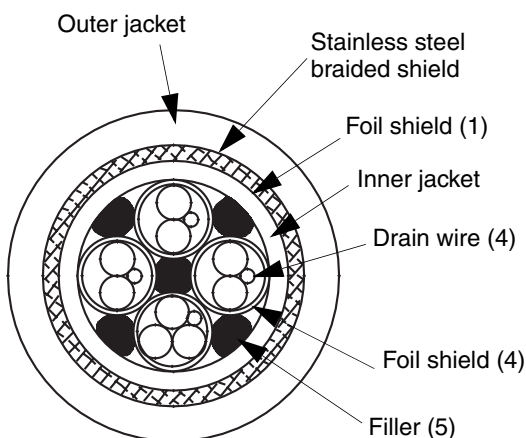

Jacket material	Outside diameter <i>inches (mm)</i>	Minimum bend radii	
		Static (no load) condition <i>inches (mm)</i>	Under dynamic load <i>inches (mm)</i>
PVC	0.525 (14)	4 1/4 (108)	8 1/2 (216)
Teflon® FEP	0.425 (11)	3 1/4 (83)	6 3/8 (162)

Table 3-1 Temperature ranges for jacket material

Jacket material	Low operating temperature limit	High operating temperature limit
PVC	-40 °F (-40 °C)	221 °F (105 °C)
Teflon® FEP	-76 °F (-60 °C)	302 °F (150 °C)

Table 3-2 Cable selection guidelines

Installation requirements	Jacketed cable	Shielded cable	Armored cable
Conduit is used	✓		
Conduit is not used		✓	
Conduit is not used and mechanical protection is required			✓

3.4.2 Guidelines for conduit

If sealed metallic conduit is installed, it must provide 360° termination shielding for the enclosed flowmeter cable.

1. Install a drip leg in conduit to prevent liquids from entering the junction box.
2. Connect the sealed end of the conduit to the 3/4-inch NPT female conduit opening on the sensor junction box.

3.4.3 Guidelines for cable gland

1. Prepare cable ends and assemble the supplied cable gland according to the instructions that are enclosed with the cable preparation kit.
2. Connect the 3/4-inch NPT male cable gland to the 3/4-inch NPT female conduit opening on the sensor junction box.

3.4.4 Wiring connections to sensor

1. At the sensor, insert the ends of the individual wires into the terminals inside the sensor junction box. Match the wire colors of the cable with the wire colors at the sensor wiring terminal as described in Figure 3-7 and Table 3-3. No bare wire should remain exposed.
2. If possible, position the junction box on the sensor so the conduit entrance points downward to prevent moisture from entering.
3. At the transmitter, if cable is not preinstalled, connect the cable to the transmitter terminals as indicated in Figure 3-8.

WARNING

Failure to seal sensor junction box or transmitter housing could cause a short circuit, which would result in measurement error or flowmeter failure.

- Seal all conduit openings.
- Install drip legs in cable or conduit.
- Fully tighten sensor junction box and transmitter housing covers. See Figure 3-8.

Figure 3-7 Cable connections to sensors

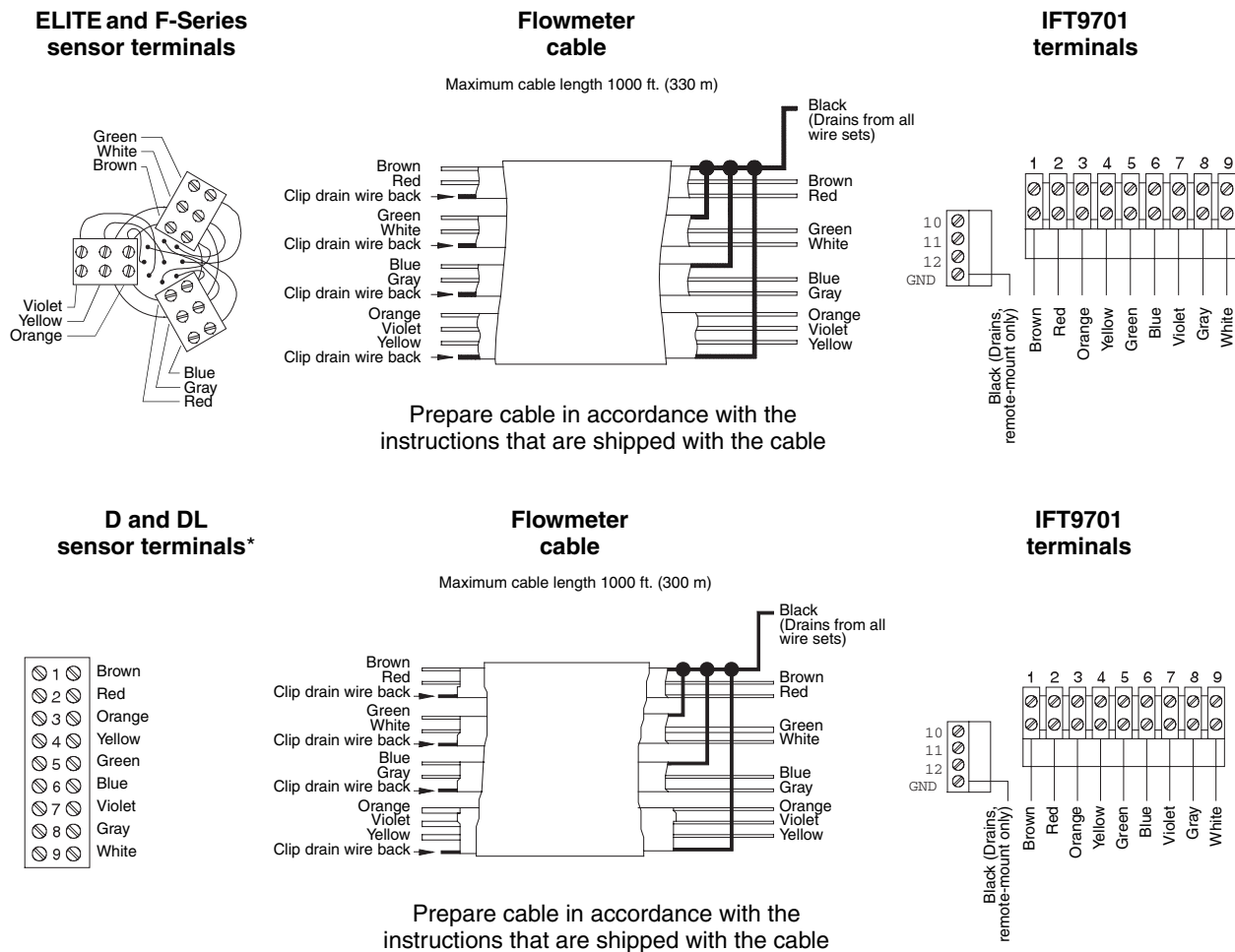

*Model D600 and DT sensors cannot be used with IFT9701 transmitters

Table 3-3 Sensor terminal designations

Terminal number	Wire color	Function
1	Brown	Drive +
2	Red	Drive -
3	Orange	Temperature -
4	Yellow	Temperature lead length compensator
5	Green	Left pickoff +
6	Blue	Right pickoff +
7	Violet	Temperature +
8	Gray	Right pickoff -
9	White	Left pickoff -

Figure 3-8 Sensor wiring compartment and sensor wiring terminals

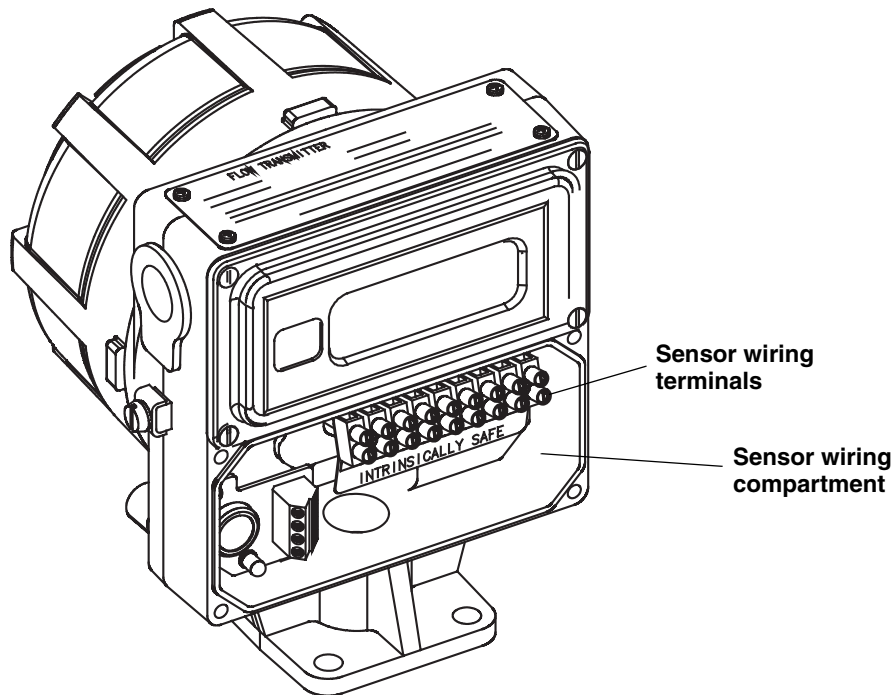

Chapter 4

Power Supply and Output Wiring

4.1 Overview

To wire the transmitter power supply and outputs:

- Review the wiring guidelines (see Section 4.2)
- Connect the power supply wiring (see Section 4.3)
- Connect the output wiring (see Section 4.4)

4.2 Wiring guidelines

- Install cable and wiring so they meet local code requirements.
- The transmitter has two separate $\frac{3}{4}$ -inch NPT or M20 female conduit openings, which must remain sealed to keep the transmitter watertight. See Figure 4-1 and Figure 4-2.
- The transmitter has a sensor wiring compartment for intrinsically safe sensor wiring, and a field wiring compartment for non-intrinsically safe power supply and output wiring. See Figure 4-1 and Figure 4-2.
 - For power supply and output wiring, loosen the four captive screws that secure the cover of the field wiring compartment.
 - Access to the sensor wiring and circuit board compartments is not required for power supply and output wiring.

4.3 Connect power supply wiring

⚠ CAUTION

Incorrect voltage, or installation with power supply on, could cause transmitter damage or failure.

- Match power supply voltage with voltage indicated on label in field wiring compartment.
- Shut off power before installing transmitter.

- Figure 4-1 shows the power supply wiring terminals.
- Wiring terminals accommodate 20 AWG (0,5 mm²) to 16 AWG (1,5 mm²) wire. If the transmitter has a DC power supply, see Table 4-1 for wire length and size guidelines.
- Connect power supply wiring to the power supply terminals.
- A switch may be installed in the power supply line. For compliance with low-voltage directive 73/23/EEC, a switch in close proximity to the transmitter is required.
- Do not install power cable in the same conduit or cable tray as flowmeter cable or output wiring.
- The transmitter must be grounded with a maximum impedance of 1 ohm. Either the internal ground screw or external case ground screw may be used as required by local policy or code.

Figure 4-1 Power supply wiring terminals

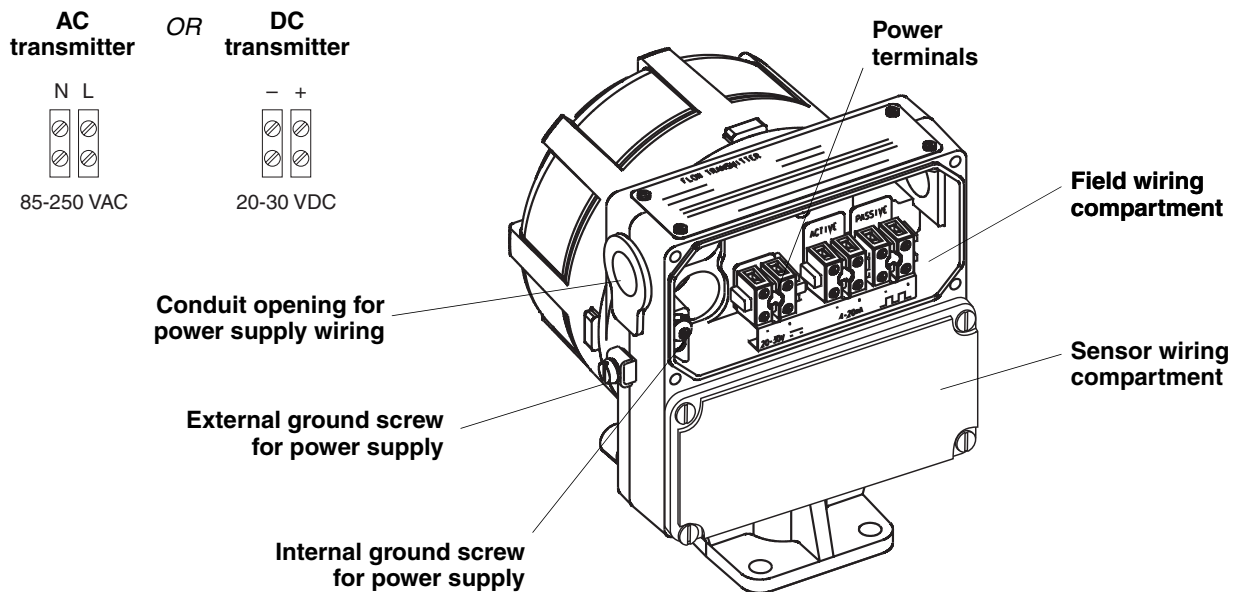

If national standards are not in effect, adhere to these guidelines for grounding:

- Use copper wire, 14 AWG (2,5 mm²) or larger wire size.
- Keep all ground leads as short as possible, less than 1 ohm impedance.
- Connect ground leads directly to earth, or follow plant standards.
- For hazardous area installation in Europe, use standard EN 60079-14 as a guideline.

Table 4-1 Wire guidelines for DC power supply

Wire size	Wire length
16 AWG (1,5 mm ²)	1500 feet (450 meters)
18 AWG (0,75 mm ²)	1000 feet (300 meters)
20 AWG (0,5 mm ²)	600 feet (200 meters)

4.4 Connect output wiring

- Figure 4-2 shows the milliamp and pulse output terminals.
- Install twisted-pair, shielded cable, consisting of 20 AWG (0,5 mm²) to 16 AWG (1,5 mm²) wire.
- For basic information on milliamp output wiring, see Section 4.4.1.
- For instructions on connecting the milliamp output to a Bell 202 multidrop network, see Section 4.4.2.
- For instructions on connecting a HART device to the milliamp output, see Section 4.4.3.
- For instructions on pulse output wiring, see Section 4.4.4.

Figure 4-2 Output wiring terminals

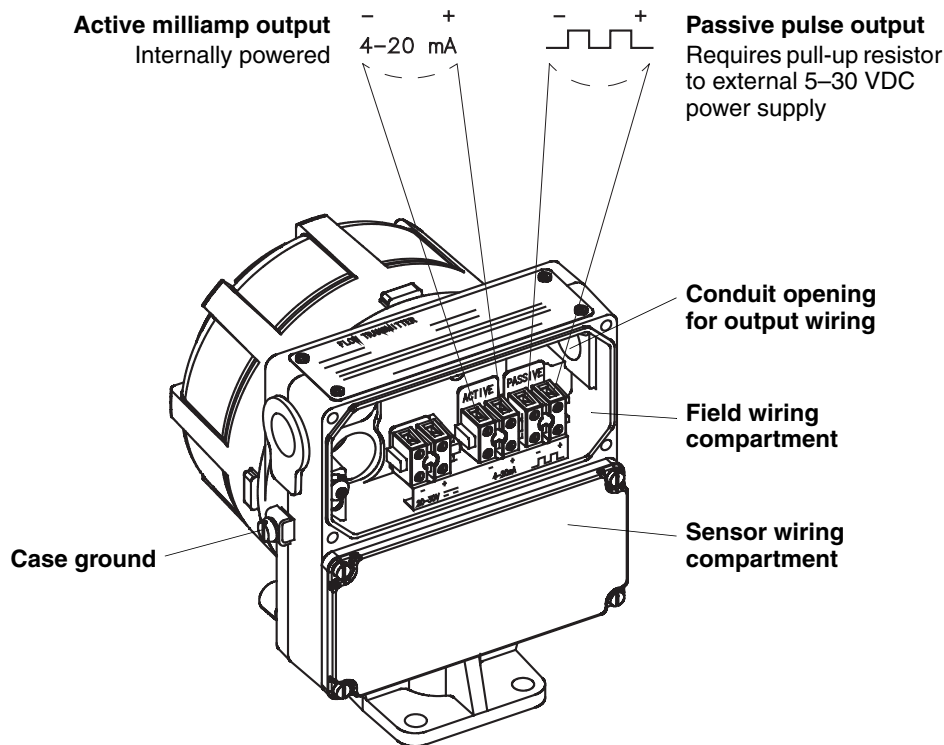

- Terminate output cable shielding at gland or conduit fitting.
- 360° termination of shielding is not necessary.
- Do not terminate shield inside wiring compartment.
- The pull-up resistor must be of sufficient value to limit the total loop current to less than 500 ohms. Refer to Section 4.4.4 to determine the pull-up resistor needed.

4.4.1 Milliamp output

The 4–20 mA output is an active output that can represent the mass or volume flow rate. At the factory, the output is configured to represent the range of flow rates that are measured in the application. The milliamp output is active, does not require external power, and has the following features:

- Can supply any loop-powered process indicator.
- Isolated to ± 500 VDC from all other outputs and earth ground.
- Requires loop resistance of 250 to 600 ohms to produce digital signals for communication via HART protocol.
- For milliamp output, the negative terminal can be grounded or left floating. If the output communicates via HART protocol, the negative terminal should be grounded for optimal performance.

Milliamp output performance is described below and illustrated in Figure 4-3.

⚠ CAUTION

Milliamp output range has changed.

Milliamp outputs will not output live signals between 2.0 and 3.8 mA, or between 20.5 and 22 mA.

Systems that rely on milliamp output signals in the ranges listed above might not perform as expected. For IFT9701 transmitters shipped after October 1999, outputs will saturate at 3.8 and 20.5 mA, unlike previous versions of IFT9701 transmitters.

Reconfigure systems as necessary.

In compliance with the NAMUR NE43 standard:

- To represent process data, the milliamp output will produce a live signal in the range of 3.8–20.5 mA.
- The milliamp output will never produce a signal in the range of 2.0–3.8 mA, or in the range of 20.5–22 mA.
- To indicate a fault, the milliamp output will produce a signal of 2 or 22 mA. The fault output level is determined by the fault-output jumper setting — downscale or upscale — as described in Section 2.3.2.

Figure 4-3 Milliamp output performance



4.4.2 Milliamp output connected to Bell 202 multidrop network

Devices in a Bell 202 multidrop network communicate by sending and receiving signals to and from one another. HART protocol supports up to 15 transmitters in a Bell 202 multidrop network.

Other Rosemount SMART FAMILY transmitters can also participate in a HART-compatible network.

- A Bell 202 multidrop network uses twisted-pair wire, and allows only digital communication.
- A HART Communicator or other HART-compatible control system can communicate with any device in the network over the same 2-wire pair.

Using multiple transmitters in a HART-compatible network requires assigning a unique address other than 0 to each transmitter. Assigning an address other than 0 to the transmitter causes the primary mA output to remain at a constant 4 mA level.

Figure 4-4 shows how to connect wiring for a HART-compatible network.

- The maximum number depends upon the type of transmitters, the method of installation, and other external factors.
- The primary mA output must produce a 4–20 mA current for the Bell 202 physical layer. The Bell 202 layer will work when the primary mA output is at or above 2 mA output.
- SMART FAMILY devices require a minimum loop resistance of 250 ohms. Loop resistance must not exceed 600 ohms.

Connect the mA outputs from each transmitter together so they terminate at a common load resistor, with at least 250 ohms impedance, installed in series.

Figure 4-4 Typical HART network wiring

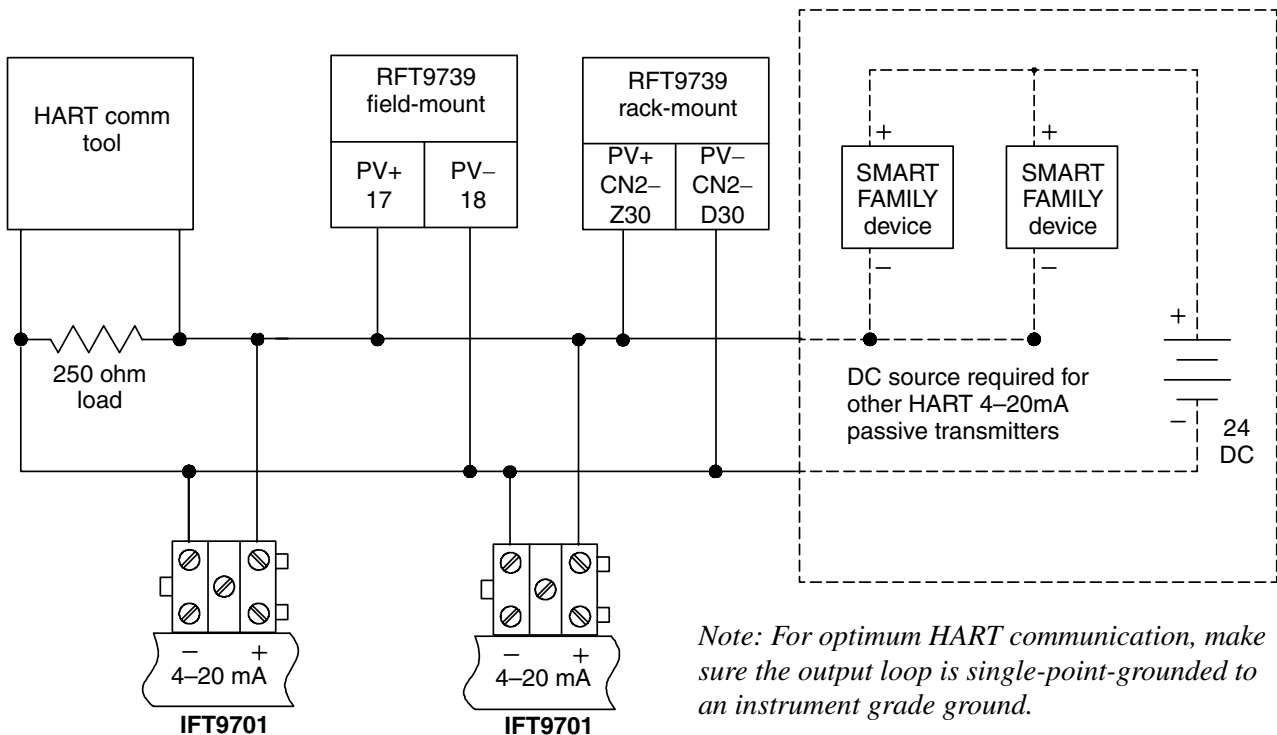

4.4.3 Communication tools connected to milliamp output

ProLink II software from Micro Motion, AMS software from Emerson Process Management, or a HART Communicator can be connected to the flowmeter's milliamp output.

To connect using ProLink II, follow the instructions in the ProLink II manual. The AMS interface is similar to the ProLink II interface. See the AMS manual for AMS-specific information.

To connect using a HART Communicator:

- Use the Bell 202-compatible cable that is supplied with the HART Communicator.
- Refer to the illustration and instructions below for wiring instructions.

Figure 4-5 HART Communicator connections

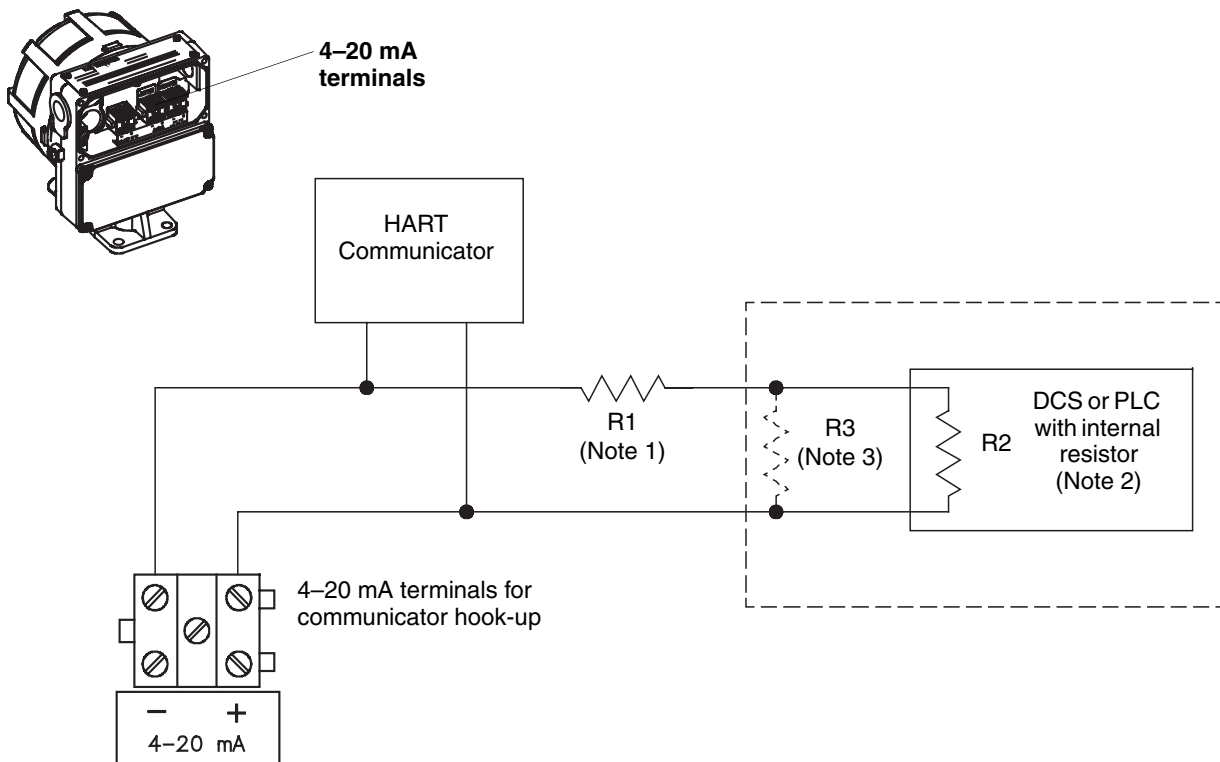

- (1) If necessary, add resistance in the loop by installing resistor R1. SMART FAMILY® devices require a minimum loop resistance of 250 ohms. Loop resistance must not exceed 600 ohms, regardless of the communication setup.
- (2) The DCS or PLC must be configured for an active milliamp signal.
- (3) Resistor R3 is required if the DCS or PLC does not have an internal resistor.

⚠ CAUTION

Connecting a HART device to the IFT9701 milliamp output loop could cause transmitter output error.

If the primary variable is being used for flow control, connecting a HART device to the milliamp output loop could cause the transmitter 4–20 mA output to change, which would affect flow control devices.

Set control devices for manual operation before connecting a HART device to the IFT9701 milliamp output loop.

4.4.4 Pulse output

The pulse output is a passive, open collector interface that can be connected to a pulse counter such as the Micro Motion Series 3000 applications platform. The output has a range of 0.1 to 7200 Hz, which represents the mass or volume flow rate. At the factory, the output is scaled so that the frequency is proportional to the range of flow rates measured in the application.

- The pulse output is galvanically isolated to ± 500 VDC from the rest of the flowmeter.
- When connected to the Series 3000 applications platform, the pulse output does not require an external power source. Otherwise, the pulse output requires a 5–30 VDC power source.
- In the ON state, voltage will be less than 1 V.

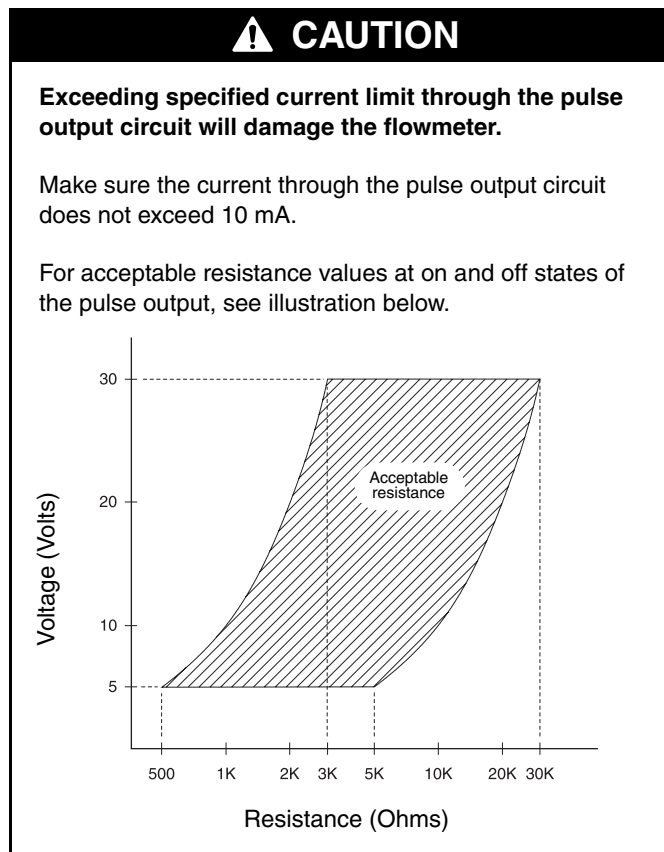

- For wiring to any pulse counter, see Figures 4-6 and 4-7.
- For wiring to the Series 3000 applications platform, see Figures 4-8 through 4-10.

Figure 4-6 Wiring to pulse counter with internal pull-up resistor

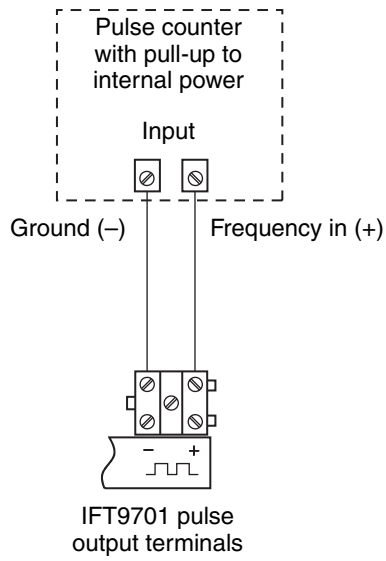

Figure 4-7 Wiring to pulse counter without internal pull-up resistor

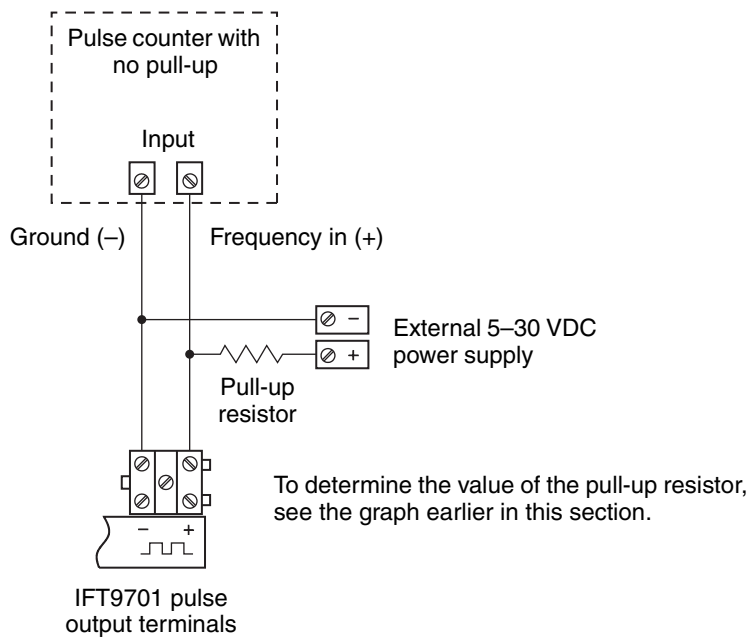
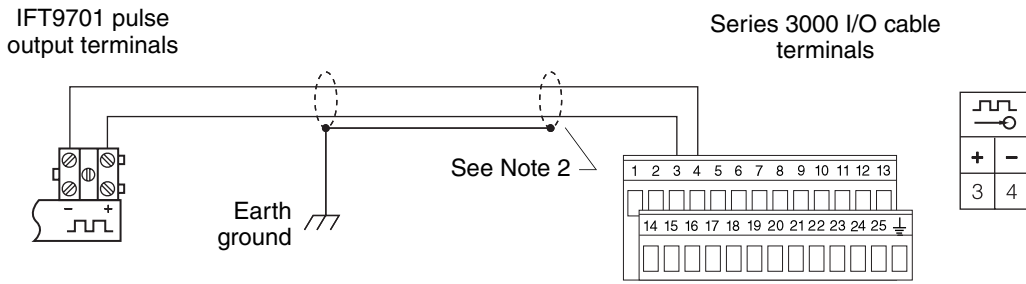
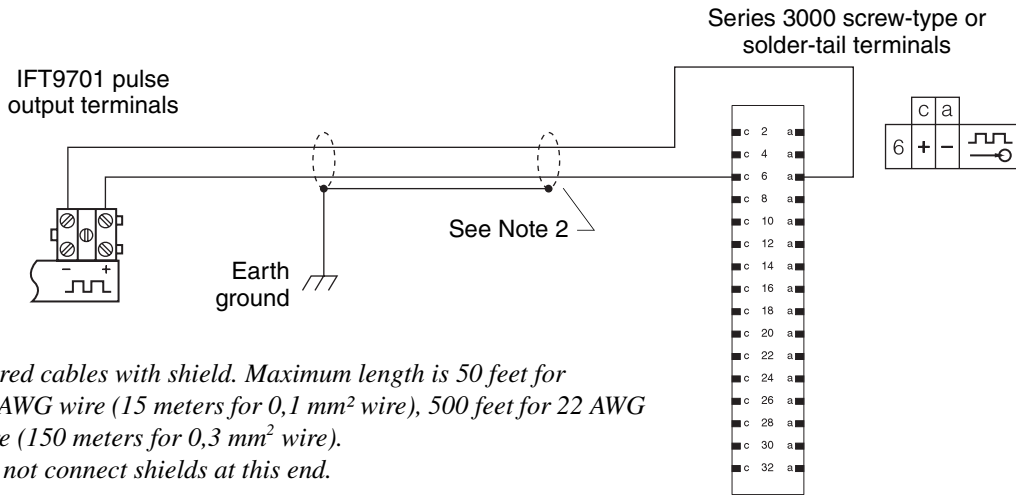

Figure 4-8 Wiring to Series 3000 applications platform with I/O cable



- (1) Paired cables with shield. Maximum length is 50 feet for 28 AWG wire (15 meters for 0,1 mm² wire), 500 feet for 22 AWG wire (150 meters for 0,3 mm² wire).
- (2) Do not connect shields at this end.

Figure 4-9 Wiring to Series 3000 applications platform with screw-type or solder-tail terminals



- (1) Paired cables with shield. Maximum length is 50 feet for 28 AWG wire (15 meters for 0,1 mm² wire), 500 feet for 22 AWG wire (150 meters for 0,3 mm² wire).
- (2) Do not connect shields at this end.

Figure 4-10 Wiring to field-mount Series 3000 applications platform

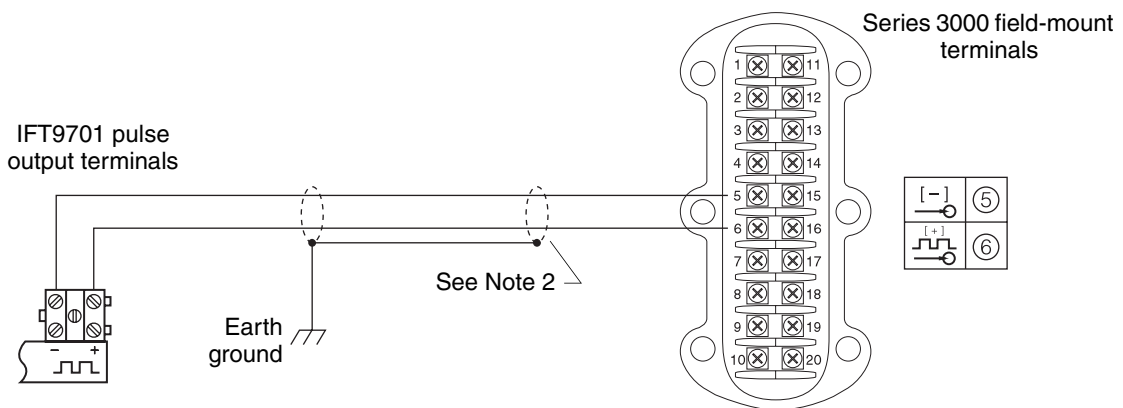

- (1) Paired cables with shield. Maximum length is 50 feet for 28 AWG wire (15 meters for 0,1 mm² wire), 500 feet for 22 AWG wire (150 meters for 0,3 mm² wire).
- (2) Do not connect shields at this end.

Chapter 5

Flowmeter Startup

5.1 Overview

This chapter describes the flowmeter startup procedures, and provides basic information about transmitter behavior.

5.2 Customer service

The Micro Motion Customer Service Department is available for assistance with flowmeter startup if you experience problems you cannot solve on your own.

If possible, provide us with the model numbers and/or serial numbers of your Micro Motion equipment, which will assist us in answering your questions. Phone numbers are listed on the title page of this manual.

5.3 Startup procedures

Startup procedures include zeroing, which is required, and calibration, which may or may not be required.

Zeroing

After the flowmeter has been fully installed, you must perform the zeroing procedure. Flowmeter zeroing establishes flowmeter response to zero flow and sets a baseline for flow measurement.

CAUTION

Failure to zero the flowmeter at initial startup could cause measurement error.

Zero the flowmeter before putting the meter in operation.

To perform the zeroing procedure:

- Using the flowmeter zero button, see Section 5.5
- Using a HART Communicator, see Chapter 6
- Using ProLink II software, see Chapter 7
- Using AMS software, see the AMS on-line help

Calibration

Calibration accounts for performance variations in individual meters and peripheral devices. For more information, see Section 5.6.

5.4 Initialization

After wiring has been connected, power can be supplied to the flowmeter. During initialization, the flowmeter remains in startup mode for 13 to 40 seconds, depending on the sensor.

5.4.1 Diagnostic LED

The diagnostic LED, shown in Figure 5-1, indicates the operating condition of the flowmeter.

5.4.2 Optional display

Except for ATEX Zone 1 areas, the transmitter is available with an optional display. See Figure 5-1. The display indicates the mass or volume flow rate or the operating condition of the transmitter.

5.4.3 Startup mode

During startup and initialization, the following status indicators can be observed:

- The diagnostic LED remains on continuously.
- Milliamp and pulse outputs go to fault levels.
- If the transmitter has an optional display, its display reads “–88.8.8.0”.
- If a HART Communicator is connected to the meter, the Communicator display reads “Field device warming up”.
- If ProLink II software is connected to the meter, the ProLink II Status window indicates “Transmitter Initializing”.

5.4.4 Operating mode

After startup, the diagnostic LED blinks ON once per second to indicate proper operation of the transmitter, and the optional display indicates the mass or volume flow rate.

Figure 5-1 Location of LED, zero button, and LCD

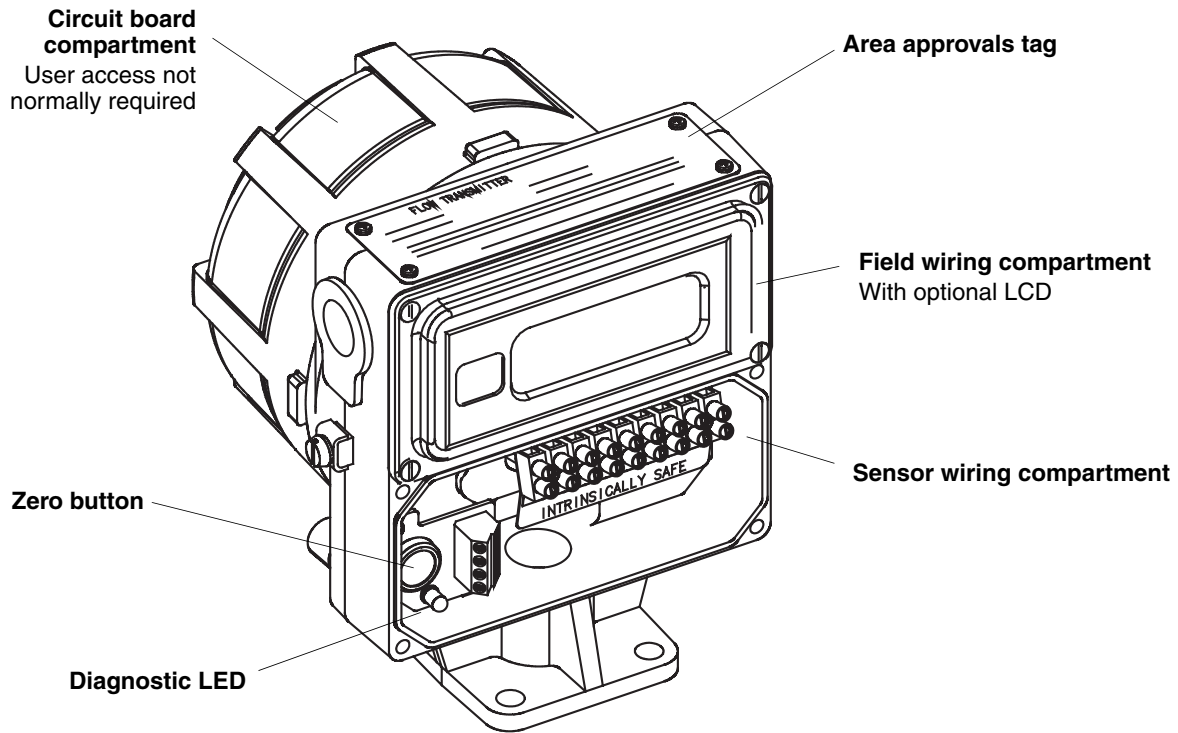

5.5 Flowmeter zeroing

After the flowmeter has been fully installed, you must perform the zeroing procedure.

- To perform the zeroing procedure using the flowmeter zero button, see the following instructions.
- To use a HART Communicator for zeroing, see Chapter 6.
- To use ProLink II software for zeroing, see Chapter 7.

5.5.1 Zeroing procedure

1. Prepare the flowmeter for zeroing:
 - a. Install the flowmeter according to the instructions in this manual.
 - b. Apply power to the meter, then allow it to warm up for at least 30 minutes.
 - c. Run the process fluid to be measured through the flowmeter until the meter temperature approximates the normal process operating temperature.
 - d. Ensure that the sensor is completely filled with fluid.
2. Close the shutoff valve downstream from the meter.

⚠ CAUTION

Flow through the flowmeter during flowmeter zeroing will result in an inaccurate zero setting.

Make sure fluid flow through the flowmeter is *completely* stopped during flowmeter zeroing.

3. Fill the flowmeter *completely* with the process fluid under normal process conditions of temperature, density, pressure, etc., and ensure zero flow through the flowmeter.
4. Make sure flow through the meter is *completely* stopped, then press and hold the zero button until the LED remains on continuously. See Figure 5-1.

To end the zero operation before its completion, cycle power to the flowmeter.

The LED remains on continuously and the optional display reads “ZERO0” for up to one minute during zeroing. After the zeroing procedure has been completed, the LED again blinks ON once per second to indicate normal operation, and the optional display again indicates the flow rate.

5.5.2 Diagnosing zero failure

If zeroing fails:

- The LED blinks ON four times per second.
- The flowmeter produces fault outputs.
- The blinking message “ELEC0” appears in the optional display.

An error condition could be caused by any of the following:

- Flow of fluid during flowmeter zeroing
- Partially empty flow tubes
- An improperly mounted flowmeter

To clear a zeroing error, cycle power, then re-zero the flowmeter after correcting the problem, or abort the procedure by cycling power to the flowmeter.

5.6 Configuration, calibration, and characterization

The following information explains the difference between configuration, calibration, and characterization. Certain parameters might require *configuration* even when *calibration* is not necessary.

Configuration parameters include such items as flow cutoff and damping values, flow direction, and milliamp output scaling. If requested at time of order, the meter is configured at the factory according to customer specifications.

Calibration parameters include the calibration factors for flow, density, and temperature. Field calibration is optional.

Characterization is the process of using a communication device to enter calibration factors for flow, density, and temperature directly into flowmeter memory, instead of performing field calibration procedures. Calibration factors can be found on the flowmeter serial number tag and on the certificate that is shipped with the meter.

To configure, calibrate, or characterize the flowmeter:

- Using a HART Communicator, see Chapter 6
- Using ProLink II software, see Chapter 7

You can also use AMS software to configure and characterize Micro Motion flowmeters. For instructions on using AMS software, refer to the AMS on-line help.

5.7 Process measurement

After flowmeter zeroing has been completed, the flowmeter is ready for process measurement.

 WARNING
<p>Operating flowmeter without compartment covers in place exposes electrical hazards that can cause property damage, injury, or death.</p> <p>Ensure all housing covers are tightly closed and fully sealed before operating the flowmeter.</p>

Chapter 6

Configuration with a HART Communicator

6.1 Configuration overview

You may use a Rosemount hand-held HART Communicator to set up the basic configuration and zero the flowmeter. The complete HART Communicator menu for the IFT9701 transmitter is provided in Appendix B; menus for specific operations are provided in this chapter.

Configuration parameters include such items as flow cutoff and damping values, flow direction, and milliamp output scaling. If requested at time of order, the meter is configured at the factory according to customer specifications. For factory-calibrated sensors, field calibration is not normally needed nor recommended. Basic configuration is described in Section 6.2.

Calibration accounts for performance variations in individual meters and peripheral devices. Calibration procedures include autozeroing and flow calibration. Zeroing is required upon initial flowmeter startup (see Section 5.3); flow calibration may or may not be required. For information on calibration procedures using a HART Communicator, see Section 6.3.

Characterization is the process of using a communication device to enter calibration factors for flow, density, and temperature directly into flowmeter memory, instead of performing field calibration procedures. Calibration factors can be found on the flowmeter serial number tag and on the certificate that is shipped with the meter. For information on characterization using a HART Communicator, see Section 6.4.

Set control devices for manual operation during flowmeter configuration.

⚠ CAUTION

Failure to set control devices for manual operation during configuration will affect flowmeter output signals.

Before using the basic setup menu, set process control devices for manual operation.

When the display depicted below appears, isolate the flowmeter from devices that use flowmeter outputs for process control, then press F4 (OK).

```
9701 Mass:M. RESET
- WARNING -
Pressing 'OK' will
change device output.
Put loop in manual.
          F4/OK
```

6.2 Configuration parameters

Use the basic setup menu to perform the following tasks:

- Assigning a HART tag to the flowmeter
- Changing measurement units for the mass or volume flow rate
- Setting range values for the milliamp output
- Scaling the pulse output

Use the detailed setup menu to perform the following tasks:

- Changing measurement units for density or temperature
- Changing the flow cutoff value
- Changing the internal damping value
- Changing the flow direction parameter

6.2.1 HART tag

The HART tag consists of up to eight characters that identify the flowmeter when it communicates with other devices in a HART multidrop network.

To assign a HART tag to a flowmeter, use the menu below and follow these steps:

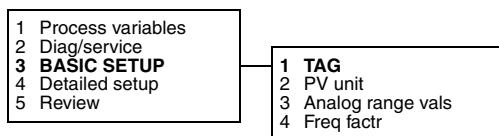

1. At the online menu, choose 3 (basic setup).
2. At the basic setup menu, choose 1 (tag).
3. Enter the desired tag of up to eight characters, then press F4 (enter). The tag can include spaces and periods.

6.2.2 Measurement units

The meter can use one mass flow unit or one volume flow unit. The meter can also provide density and temperature indication to a HART Communicator.

To select a measurement unit for mass flow or volume flow, use the menu below and follow these steps:

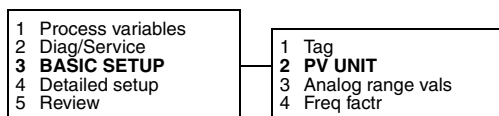

1. At the online menu, choose 3 (basic setup).
2. At the basic setup menu, choose 2 (primary variable unit).
3. Use the down arrow (↓) or up arrow (↑) to select the desired measurement unit, then press F4 (enter). Available measurement units for mass flow and volume flow are listed in Table 6-1.

4. Measurement units affect other field device variables, and must be sent (downloaded) to the flowmeter before other variables can be configured:
 - a. Whenever the display below appears, press F4 (OK).

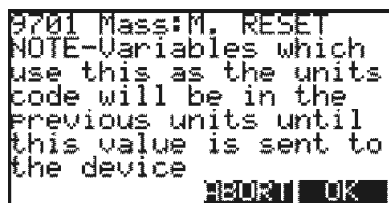

- b. To send the measurement unit to the flowmeter, press F2 (send).

Table 6-1 Measurement units for mass and volume flow

Mass flow unit	Software label	Volume flow unit	Software label
grams/second	g/s	cubic feet/second	Cuft/s
grams/minute	g/min	cubic feet/day	Cuft/d
grams/hour	g/h	cubic feet/minute	Cuft/min
kilograms/second	kg/s	cubic feet/hour	Cuft/h
kilograms/minute	kg/min	cubic meters/second	Cum/s
kilograms/hour	kg/h	cubic meters/minute	Cum/min
kilograms/day	kg/d	cubic meters/hour	Cum/h
metric tonnes (1000 kg)/minute	Met Ton/min	cubic meters/day	Cum/d
metric tonnes (1000 kg)/hour	Met Ton/h	U.S. gallons/second	gal/s
metric tonnes (1000 kg)/day	Met Ton/d	U.S. gallons/minute	gal/min
pounds/second	lb/s	U.S. gallons/hour	gal/h
pounds/minute	lb/min	liters/second	L/s
pounds/hour	lb/h	liters/minute	L/min
pounds/day	lb/d	liters/hour	L/h
short tons (2000 pounds)/minute	S Ton/min	Imperial gallons/second	Impgal/s
short tons (2000 pounds)/hour	S Ton/h	Imperial gallons/minute	Impgal/min
short tons (2000 pounds)/day	S Ton/d	Imperial gallons/hour	Impgal/h
		Imperial gallons/day	Impgal/d
		barrels/second	bbl/s
		barrels/minute	bbl/min
		barrels/hour	bbl/h
		barrels/day	bbl/d

To select measurement units for density and temperature, use the menu below and follow these steps:

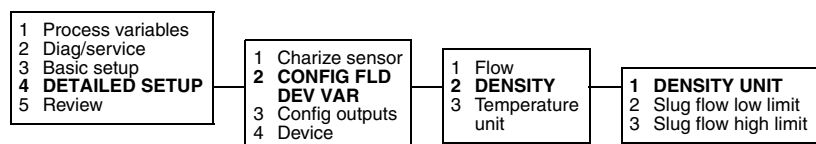

1. At the online menu, choose 4 (detailed setup).
2. At the detailed setup menu, choose 2 (configure field device variables).
3. At the configure field device variables menu, choose 2 (density).
4. At the density menu, choose 1 (density unit).
5. Use the down arrow (↓) or up arrow (↑) to select the desired measurement unit, then press F4 (enter).
6. To send the density unit to the flowmeter, press F2 (send).

Configuration with a HART Communicator *continued*

7. At the detailed setup menu, choose 2 (configure field device variables).
8. At the configure field device variables menu, choose 3 (temperature unit).
9. Repeat steps 5 and 6 to choose and enter a temperature unit.

6.2.3 Flow cutoff

In some sensor installations, noise caused by mechanical sources, such as valves and motors, can affect flowmeter output signals. The flow cutoff filters out noise by defining the measured value below which the milliamp output indicates zero flow.

The flow cutoff is the lowest flow rate at which the meter produces a nonzero output signal. If flow drops below the cutoff:

- The pulse output goes to 0 Hz.
- The internal totalizer stops counting.
- The meter indicates zero flow during polling from a host controller.

A default flow cutoff is entered into the flowmeter at the factory. This number can be adjusted to achieve the filter effect described above.

To adjust the flow cutoff, use the menu below and follow these steps:

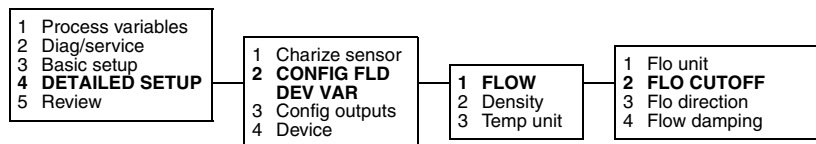

1. At the online menu, choose 4 (detailed setup).
2. At the detailed setup menu, choose 2 (configure field device variables).
3. At the configure field device variables menu, choose 1 (flow).
4. At the flow menu, choose 2 (flow cutoff).
5. Enter the desired flow cutoff value.
6. Press F2 (send) to send the flow cutoff to the flowmeter memory.

6.2.4 Damping

Internal damping filters out noise or the effects of rapid changes in the variable without affecting measurement accuracy.

The damping value is the filter coefficient that approximates the time required for the output to achieve 63% of its new value in response to a step change at the input. The actual time depends on many factors, including sensor type and density of the process fluid. The meter rounds down the chosen damping value to the nearest programmed filter coefficient. Programmed filter coefficients, in seconds, are:

0.1 0.2 0.4 0.8 1.6 3.2 6.4 12.8

To enter an internal damping value, use the menu below and follow these steps:

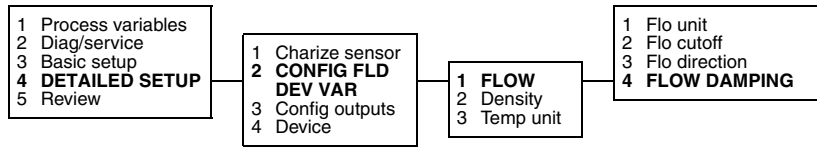

1. At the online menu, choose 4 (detailed setup).
2. At the detailed setup menu, choose 2 (configure field device variables).
3. At the configure field device variables menu, choose 1 (flow).
4. At the flow menu, choose 4 (flow damping).
5. Select the desired damping value.
6. Press F2 (send) to send the damping value to the flowmeter memory.

6.2.5 Flow direction

The configured flow direction (forward, reverse, or bi-directional) determines how flowmeter outputs and totalizers will react when fluid flows through the meter. The flow direction arrow on the meter is considered the "forward" flow direction, but the meter measures flow accurately in either direction.

To configure flow direction for the meter, use the menu below and follow these steps:

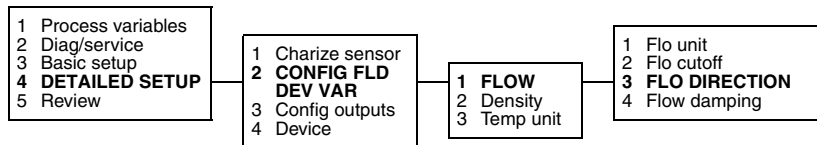

1. At the online menu, choose 4 (detailed setup).
2. At the detailed setup menu, choose 2 (configure field device variables).
3. At the configure field device variables menu, choose 1 (flow).
4. At the flow variables menu, choose 3 (flow direction), then choose the desired option. The table below lists how outputs and totalizers are affected by the option that is chosen.
5. To send the flow direction to the flowmeter, press F2 (send).

Table 6-1 Effect of flow direction on outputs and totalizers

Fluid flow direction	Output or totalizer	Flowmeter configuration	
		Forward	Reverse
Fluid flowing in <i>same direction</i> as flow arrow on sensor	Milliamp output	Output increases as flow rate increases	Output goes to 3.8 mA
	Pulse output	Output increases as flow rate increases	Output remains at 0 Hz
	Internal totalizers	Flow totals increase	Flow totals remain constant
Fluid flowing in <i>opposite direction</i> from flow arrow on sensor	Milliamp output	Output goes to 3.8 mA	Output increases as flow rate increases
	Pulse output	Output remains at 0 Hz	Output increases as flow rate increases
	Internal totalizers	Flow totals remain constant	Flow totals increase

6.2.6 Range values for milliamp output

Range values are the flow rates represented by the milliamp output at 4 mA and at 20 mA.

To set range values, use the menu below and follow these steps:

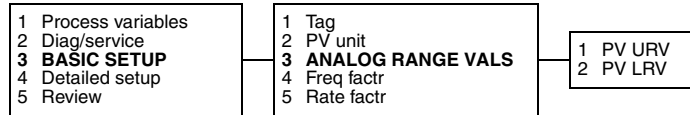

1. At the online menu, choose 3 (basic setup).
2. At the basic setup menu, choose 3 (analog range values).
3. Choose the upper or lower range value for setting.
 - To set the upper range value, which is the flow rate represented by the output at 20 mA, choose 1 (primary variable upper range value), or
 - To set the lower range value, which is the flow rate represented by the output at 4 mA, choose 2 (primary variable lower range value).
4. Enter the desired range value, then press F4 (enter).
5. To send the range values to the flowmeter, press F2 (send).

6.2.7 Pulse output scaling

The pulse output produces a frequency proportional to the flow rate. Pulse output scaling requires entry of frequency and flow rate values.

To scale the pulse output, use the menu below and follow these steps:

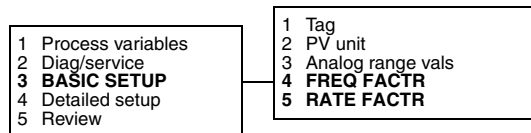

1. At the online menu, choose 3 (basic setup).
2. At the basic setup menu, choose 4 (frequency factor).
3. Enter a value for the frequency in pulses per second (Hertz) that corresponds to the maximum flow rate, then press F4 (enter).
4. When the HART Communicator display returns to the basic setup menu, choose 5 (rate factor).
5. Enter the maximum value of the flow rate, then press F4 (enter). The entered value corresponds to the frequency that was entered in Step 3.
6. To send the pulse output scaling to the flowmeter, press F2 (send).

6.3 Calibration procedures

Calibration procedures include zeroing and flow calibration.

6.3.1 Auto zero

Flowmeter zeroing establishes flowmeter response to zero flow and establishes a baseline for flow measurement.

⚠ CAUTION

Failure to zero the flowmeter at initial startup could cause measurement error.

Zero the flowmeter before putting the flowmeter into operation.

To perform the auto zero, follow these steps:

1. Prepare the flowmeter for zeroing:
 - a. Install the flowmeter according to the instructions in this manual.
 - b. Apply power to the meter, then allow it to warm up for at least 30 minutes.
 - c. Run the process fluid to be measured through the flowmeter until the meter temperature approximates the normal process operating temperature.
2. Close the shutoff valve downstream from the meter.
3. Fill the flowmeter *completely* with the process fluid under normal process conditions of temperature, density, pressure, etc., and ensure zero flow through the flowmeter.

⚠ CAUTION

Flow through the flowmeter during flowmeter zeroing will result in an inaccurate zero setting.

Make sure fluid flow through the flowmeter is **completely** stopped during flowmeter zeroing.

4. To initiate the auto zero procedure, use the menu below and follow these steps:

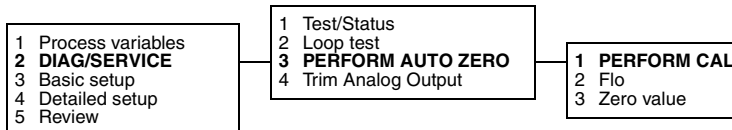

- a. At the online menu, choose 2 (diagnostics/service).
- b. At the diagnostics/service menu, choose 3 (perform auto zero).
- c. At the perform auto zero menu, choose 1 (perform calibration).

Configuration with a HART Communicator *continued*

- d. When the display reads “WARN Loop should be removed from automatic control”, isolate the flowmeter from devices that use flowmeter outputs to control the process, then choose F4 (OK).
- e. When the display reads “Flow must be zero, perform calibration?”, make sure flow through the sensor is *completely* stopped, then press F4 (OK).
 - The HART Communicator display reads “Calibration in progress” to indicate flowmeter zeroing in progress.
 - The meter’s diagnostic LED remains ON and the meter’s optional display reads “ZERO0” for up to one minute during zeroing.
 - To end the zero operation before its completion, press F3 (abort).
- f. When flowmeter zeroing is completed, the LED blinks ON once per second to indicate normal operation, the optional display indicates the flow rate, and the HART Communicator display reads “Auto zero complete”. Press F4 (OK).

Diagnosing zeroing failure

If zeroing fails:

- The HART Communicator display reads “Auto zero failure”.
- The meter’s diagnostic LED blinks ON four times per second.
- The flowmeter produces fault outputs.
- The blinking message “ELEC0” appears in the meter’s optional display.

To abort the zeroing procedure, press F3 (abort).

To re-zero, make sure flow is completely shut off and flowmeter tubes are completely filled with fluid, then press F4 (OK).

The most common sources of zeroing failure are:

- Flow of fluid through meter during zeroing
- Partially empty flow tubes
- An improperly mounted meter

Re-zero the flowmeter after correcting the problem, or cycle power to the meter to abort the entire zeroing procedure and return to the previously established zero.

6.3.2 Flow calibration procedure

Flow calibration involves adjusting the flow calibration factor so it accurately represents the sensitivity of the flowmeter to mass flow. Performing the flow calibration procedure in the field is optional.

Flow calibration is performed by running a batch of fluid through the meter, weighing the fluid, then using the HART Communicator to compare the weighed amount with the amount of fluid indicated by the flowmeter’s mass totalizer. The accuracy of the scale used for weighing the fluid will determine the accuracy of the flow calibration. Use a scale that is highly accurate.

Use a mass flow unit during the calibration procedure. If the application requires volume flow measurement, choose a mass flow unit for the flow calibration, then choose a volume flow unit for the application.

To calculate the flow calibration factor:

1. Select a mass flow unit, and send the unit to the flowmeter memory. See Table 6-1.
2. To enter the flow calibration factor into flowmeter memory, refer to the menu below and follow these steps:

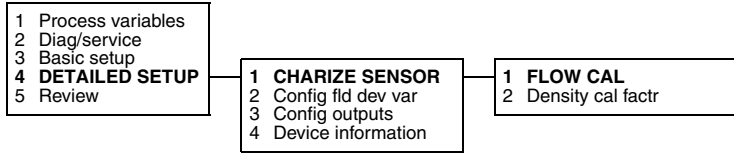

- a. At the online menu, choose 4 (detailed setup).
 - b. At the detailed setup menu, choose 1 (characterize sensor).
 - c. At the characterize sensor menu, choose 1 (flow calibration factor).
 - d. Enter the 8-digit flow calibration factor listed on the flowmeter serial number tag. The flow calibration factor can also be found on the certificate that is shipped with the meter.
 - e. When the display returns to the characterize sensor menu, press F2 (send) to send the factor to the flowmeter memory.
3. Zero the flowmeter (see Section 6.3.1).
 4. Refer to the menu below, and follow these steps:

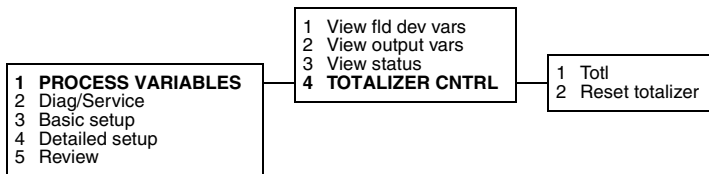

- a. Reset the internal totalizer to zero.
- b. Run three batches of fluid, resetting the scale and totalizer between batches. For each batch, record the weights indicated by the scale and the totalizer.

	Weight_{scale}	Weight_{totalizer}
First batch	_____	_____
Second batch	_____	_____
Third batch	=====	=====
Total	_____	_____

5. Divide *Total Weight_{scale}* by *Total Weight_{totalizer}*. This is the mass-flow meter factor. Record the meter factor.

Mass-flow meter factor _____

Configuration with a HART Communicator *continued*

- Multiply the meter factor from Step 5 by the first five digits of the current flow calibration factor. This is the first five digits of the new flow calibration factor.

First 5 digits of new FloCal factor _____

- To enter the new flow calibration factor into flowmeter memory, refer to the menu below and follow these steps:

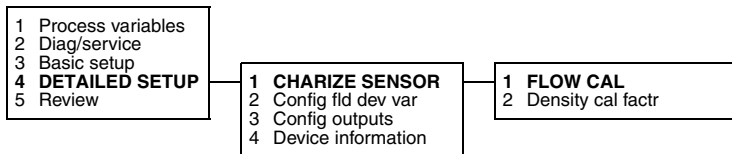

- At the online menu, choose 4 (detailed setup).
 - At the detailed setup menu, choose 1 (characterize sensor).
 - At the characterize sensor menu, choose 1 (flow calibration factor).
 - Type in the new flow calibration factor, then press F4 (enter):
 - For the first five digits and first decimal point, use the value determined in Step 6.
 - For the last three digits and second decimal point, use the last three digits and second decimal point from the flow calibration factor listed on the flowmeter serial number tag.
 - When the display returns to the characterize sensor menu, press F2 (send) to send the factor to the flowmeter memory.
- To verify the accuracy of the new flow calibration factor, repeat Step 4. The amount of fluid indicated by the mass totalizer should equal the weighed amount of fluid in the batch, within accuracy specifications provided by Micro Motion for the flowmeter.

6.4 Characterization

Characterization involves entering a density calibration factor that accurately represents the sensitivity of the flowmeter to fluid density.

To characterize the flowmeter for density measurement, refer to the menu below and follow these steps:

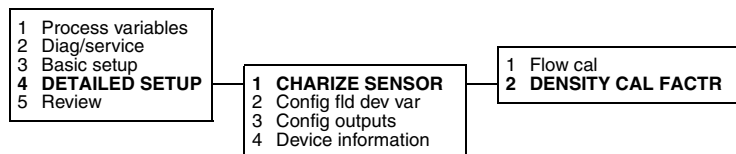

- At the online menu, choose 4 (detailed setup).
- At the detailed setup menu, choose 1 (characterize sensor).
- At the characterize sensor menu, choose 2 (density calibration factor).
- Enter the 13-digit density calibration factor listed on the flowmeter serial number tag. The density calibration factor can also be found on the certificate that is shipped with the meter.
- When the display returns to the characterize sensor menu, press F2 (send) to send the factor to the flowmeter memory.

Chapter 7

Configuration with ProLink II Software

7.1 Configuration overview

You may use the Micro Motion ProLink II software, installed on a personal computer, to set up the basic configuration and zero the flowmeter. See the ProLink II manual or on-line help for additional information.

Configuration parameters include such items as flow cutoff and damping values, flow direction, and milliamp output scaling. If requested at time of order, the meter is configured at the factory according to customer specifications. For factory-calibrated sensors, field calibration is not normally needed nor recommended. Basic configuration is described in Section 7.2.1.

Calibration accounts for performance variations in individual meters and peripheral devices. Calibration procedures include autozeroing and flow calibration. Zeroing is required upon initial flowmeter startup (see Section 4.3); flow calibration may or may not be required. For information on calibration procedures using ProLink II, see Section 7.3.

Characterization is the process of using a communication device to enter calibration factors for flow, density, and temperature directly into flowmeter memory, instead of performing field calibration procedures. Calibration factors can be found on the flowmeter serial number tag and on the certificate that is shipped with the meter. For information on characterization using ProLink II, see Section 7.4.

Set control devices for manual operation during flowmeter configuration.

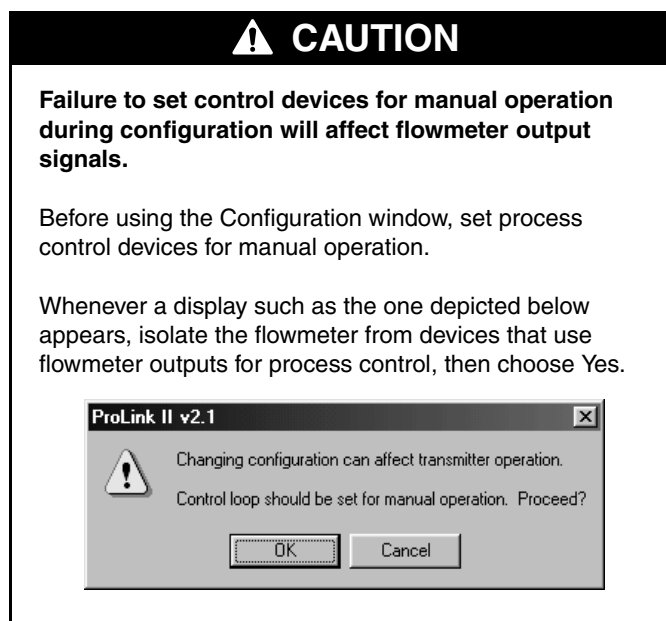

7.2 Configuration parameters

Use the Configuration window to perform the following tasks:

- Assigning a HART tag to the flowmeter
- Changing process variable measurement:
 - Changing measurement units for the mass flow or volume flow rate
 - Changing the flow cutoff value
 - Changing the internal damping value
 - Changing the flow direction parameter
- Setting range values for the milliamp output
- Scaling the pulse output

7.2.1 HART tag

The HART tag consists of up to eight characters that identify the flowmeter when it communicates with other devices in a HART multidrop network.

To assign a HART tag to a flowmeter:

1. From the ProLink menu, click on Configuration.
2. In the Configuration window, click on the Device tab.
3. When the Device panel appears (as depicted in Figure 7-1), enter the desired tag of up to eight characters, then click on OK. The tag can include spaces and periods.

Figure 7-1 Configuration window – Device panel

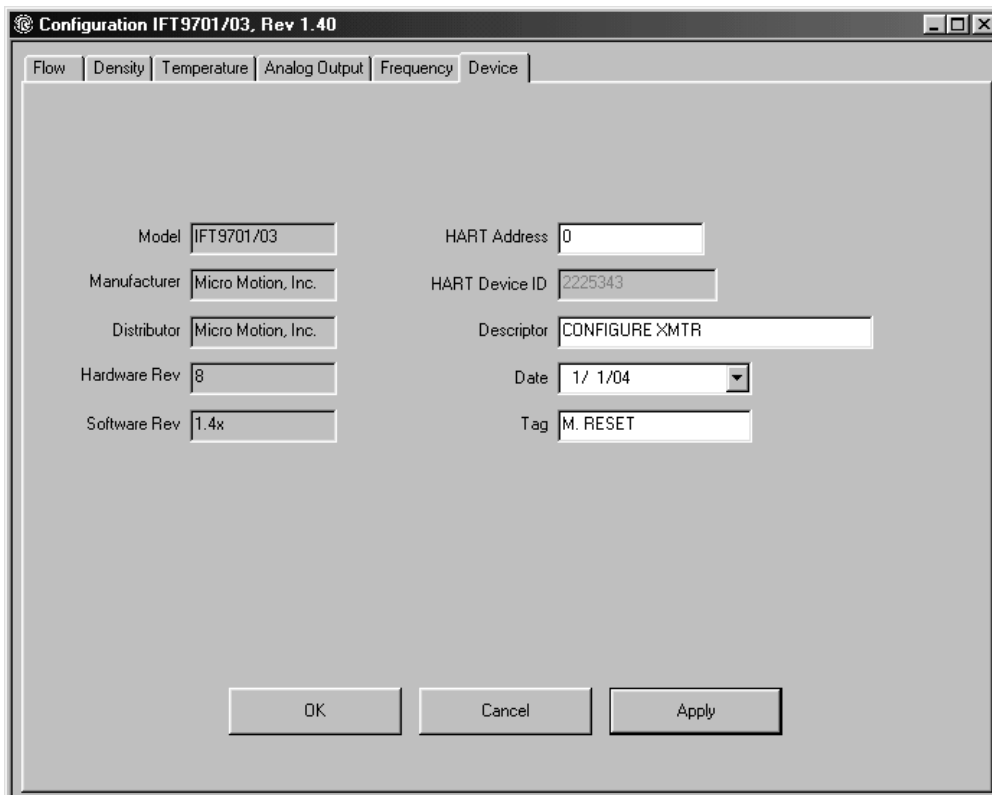

7.2.2 Process variable measurement

To configure process variable measurement:

1. From the ProLink menu, click on Configuration.
2. In the Configuration window, click on the Flow tab. The Flow panel appears (as depicted in Figure 7-2).

Figure 7-2 Configuration window – Flow panel

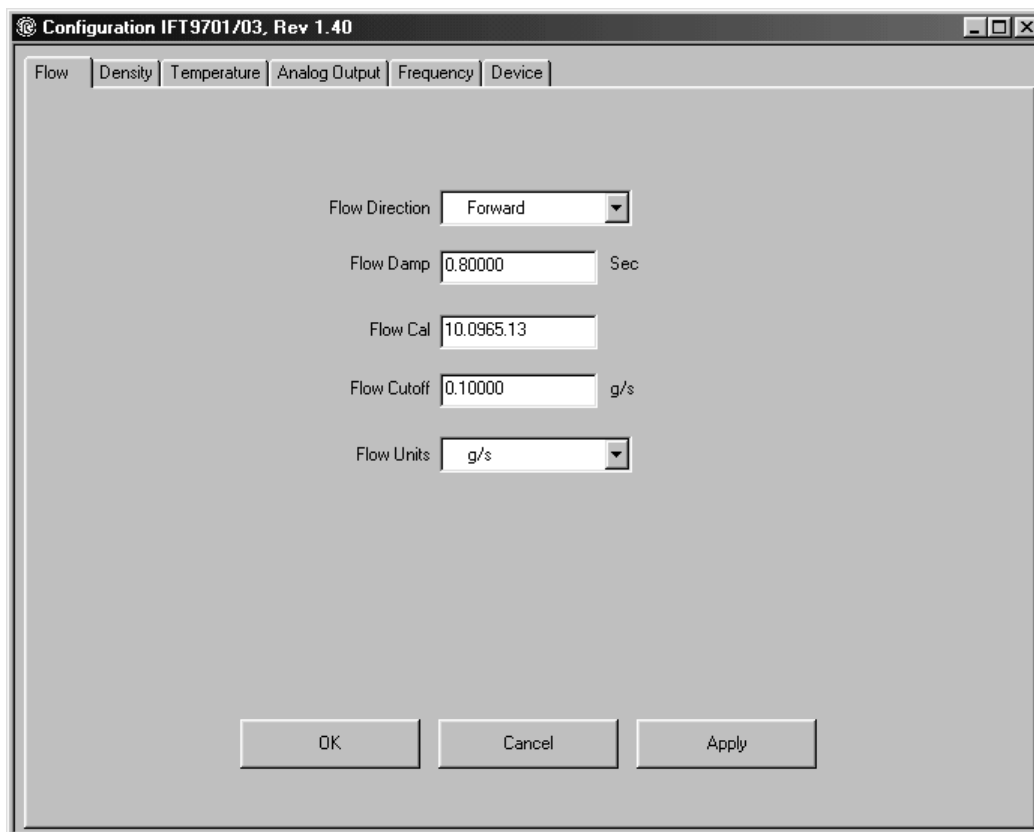

3. To specify the flow measurement unit, open the Flow Units list box and select a flow unit. If you select a unit of mass flow, the transmitter will measure mass flow. If you select a unit of volume flow, the transmitter will measure volume flow. A list of available flow measurement units is provided in Table 7-1.

Table 7-1 Measurement units for mass and volume flow

Mass flow unit	Software label	Volume flow unit	Software label
grams/second	g/s	U.S. gallons/second	USgps
grams/minute	g/min	U.S. gallons/minute	USgpm
grams/hour	g/hr	U.S. gallons/hour	USgph
kilograms/second	kg/s	liters/second	l/s
kilograms/minute	kg/min	liters/minute	l/min
kilograms/hour	kg/hr	liters/hour	l/hr
kilograms/day	kg/day	Imperial gallons/second	UKgps
metric tonnes (1000 kg)/minute	t/min	Imperial gallons/minute	UKgpm
metric tonnes (1000 kg)/hour	t/hr	Imperial gallons/hour	UKgph
metric tonnes (1000 kg)/day	t/day	Imperial gallons/day	UKgpd
pounds/second	lb/s	cubic feet/second	cuft/s
pounds/minute	lb/min	cubic feet/minute	cuft/min
pounds/hour	lb/hr	cubic feet/hour	cuft/hr
pounds/day	lb/day	cubic feet/day	cuft/day
short tons (2000 pounds)/minute	ton/min	cubic meters/second	cum/s
short tons (2000 pounds)/hour	ton/hr	cubic meters/minute	cum/min
short tons (2000 pounds)/day	ton/day	cubic meters/hour	cum/hr
		cubic meters/day	cum/day
		barrels/second	bbl/s
		barrels/minute	bbl/min
		barrels/hour	bbl/hr
		barrels/day	bbl/day

- In some sensor installations, noise caused by mechanical sources, such as valves and motors, can affect flowmeter output signals. The flow cutoff filters out noise by defining the measured value below which the milliamp output indicates zero flow.

The flow cutoff is the lowest flow rate at which the meter produces a nonzero output signal. If flow drops below the cutoff:

- The pulse output goes to 0 Hz
- The internal totalizer stops counting
- The meter indicates zero flow during polling from a host controller

A default flow cutoff is entered into the flowmeter at the factory. This number can be adjusted to achieve the filter effect described above. Enter a new value, if desired, into the Flow Cutoff text box in the Flow panel.

- The configured flow direction (forward, reverse, or bi-directional) determines how flowmeter outputs and totalizers will react when fluid flows through the meter.

The flow direction arrow on the meter is considered the “forward” flow direction, but the meter measures flow accurately in either direction. Table 7-2 lists how outputs and totalizers are affected by the option that is chosen.

To configure flow direction for outputs and totalizers, open the Flow Direction list box in the Flow panel and select the desired setting.

Table 7-2 Effect of flow direction on outputs and totalizers

Fluid flow direction	Output or totalizer	Flowmeter configuration	
		Forward	Reverse
Fluid flowing in <i>same direction</i> as flow arrow on sensor	Milliamp output	Output increases as flow rate increases	Output goes to 3.8 mA
	Pulse output	Output increases as flow rate increases	Output remains at 0 Hz
	Internal totalizers	Flow totals increase	Flow totals remain constant
Fluid flowing in <i>opposite direction</i> from flow arrow on sensor	Milliamp output	Output goes to 3.8 mA	Output increases as flow rate increases
	Pulse output	Output remains at 0 Hz	Output increases as flow rate increases
	Internal totalizers	Flow totals remain constant	Flow totals increase

- Internal damping filters out noise or the effects of rapid changes in the variable without affecting measurement accuracy.

The damping value is the filter coefficient that approximates the time required for the output to achieve 63% of its new value in response to a step change at the input. The actual time depends on many factors, including sensor type and density of the process fluid. The meter rounds down the chosen damping value to the nearest programmed filter coefficient. Programmed filter coefficients, in seconds, are:

0.1 0.2 0.4 0.8 1.6 3.2 6.4 12.8

If desired, enter an internal damping value into the Damping text box in the Flow panel.

7.2.3 Output configuration

Basic configuration of flowmeter outputs includes:

- Setting range values for the milliamp output.
- Scaling the pulse output.

To configure the milliamp output:

1. From the ProLink menu, click on Configuration.
2. Click on the Analog Output tab. The Analog Output panel appears, as shown in Figure 7-3.

Figure 7-3 Configuration window – Analog Output panel

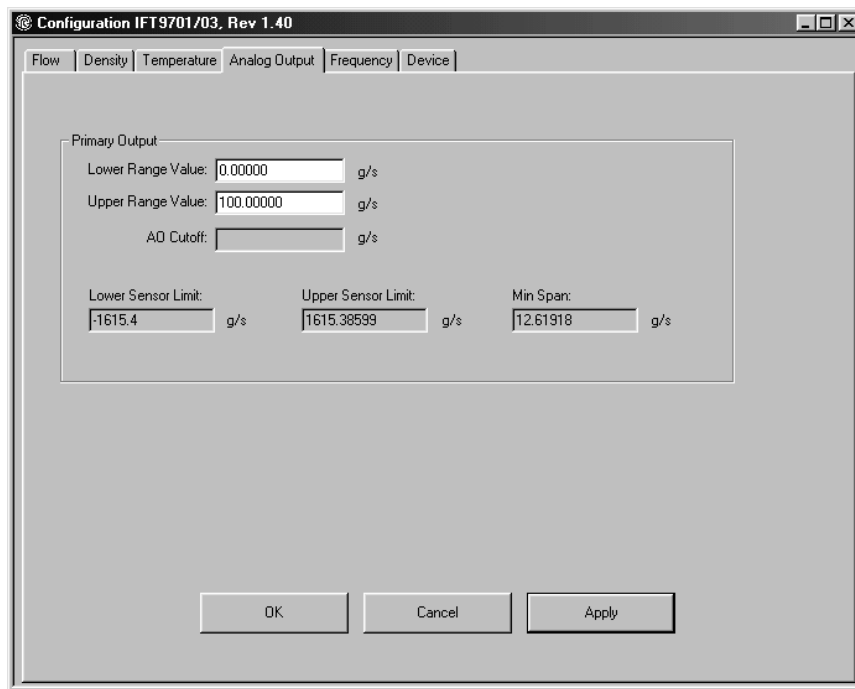

3. Range values are flow rates represented by the milliamp output at 4 mA and at 20 mA. To set range values:
 - a. Enter the flow rate that will be represented by the output at 4 mA into the Lower Range Value text box.
 - b. Enter the flow rate that will be represented by the output at 20 mA into the Upper Range Value text box.

The Low Limit, High Limit, and Minimum Span display boxes in the panel indicate flowmeter limits, in the configured flow measurement unit.

- The value entered into the Lower Range Value text box must be lower than the value entered into the Upper Range Value text box and higher than the displayed low limit.
- The value entered into the Upper Range Value text box must be higher than the displayed low limit and lower than the displayed high limit.
- The difference between the values entered into the text boxes should be greater than the displayed minimum span, or the milliamp output accuracy will be degraded.

To configure the pulse output:

1. From the ProLink menu, click on Configuration.
2. Click on the Frequency tab. The Frequency panel appears, as shown in Figure 7-3.

Figure 7-4 Configuration window – Frequency panel

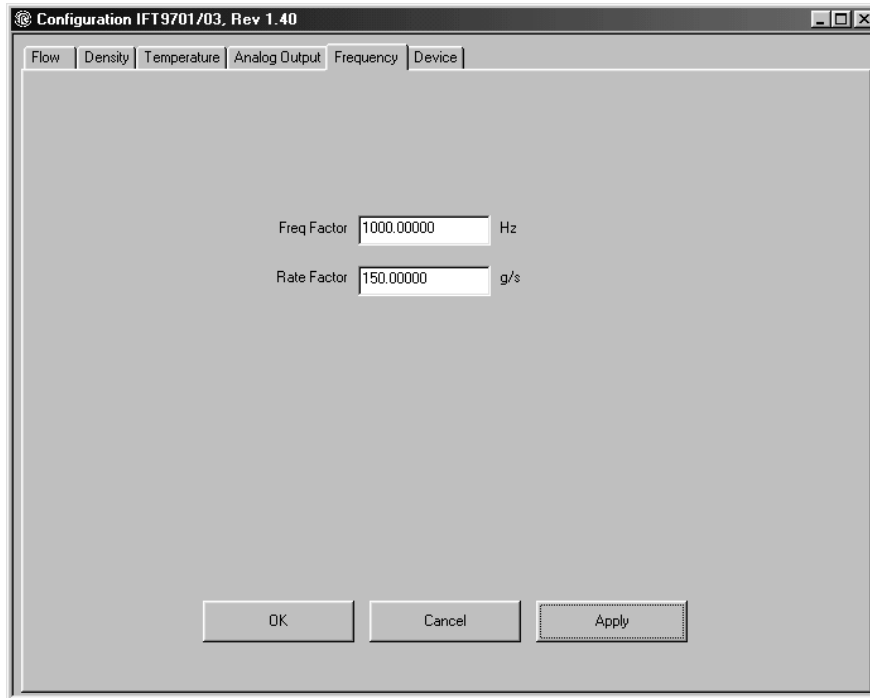

3. The pulse output produces a frequency proportional to the flow rate. Pulse output scaling requires entry of frequency and flow rate values. To scale the pulse output:
 - a. In the text box labeled Freq Factor, enter a value for the frequency in pulses per second (Hertz) that corresponds to the maximum flow rate.
 - b. In the text box labeled Rate Factor, enter the maximum value of the flow rate. The entered value corresponds to the frequency that was entered in the Freq Factor text box.

7.3 Calibration procedures

Calibration procedures include zeroing and flow calibration.

7.3.1 Auto zero

Flowmeter zeroing establishes flowmeter response to zero flow and sets a baseline for flow measurement.

 CAUTION
<p>Failure to zero the flowmeter at initial startup could cause measurement error.</p> <p>Zero the flowmeter before putting the flowmeter into operation.</p>

To perform the auto zero procedure:

1. Prepare the flowmeter for zeroing:
 - a. Install the flowmeter according to the instructions in this manual.
 - b. Apply power to the meter, then allow it to warm up for at least 30 minutes.
 - c. Run the process fluid to be measured through the flowmeter until the meter temperature approximates the normal process operating temperature.
2. Fill the flowmeter *completely* with the process fluid under normal process conditions of temperature, density, pressure, etc., and ensure zero flow through the flowmeter.
3. Close the shutoff valve downstream from the meter.

 CAUTION
<p>Flow through the flowmeter during flowmeter zeroing will result in an inaccurate zero setting.</p> <p>Make sure fluid flow through the flowmeter is <i>completely</i> stopped during flowmeter zeroing.</p>

4. Open the Calibration menu and click on Zero Calibration. The Flow Calibration dialog box appears (depicted in Figure 7-5).
5. Make sure flow through the sensor is *completely* stopped, then click the Zero button. The flowmeter begins zeroing. While zeroing is in progress:
 - The Calibration in Progress status light is red.
 - The transmitter's diagnostic LED remains ON.
 - The transmitter's optional display reads "ZERO0" for up to one minute during zeroing.

When flowmeter zeroing is completed:

- The Calibration in Progress status light turns green.
- The transmitter's diagnostic LED blinks once per second to indicate normal operation.
- The display indicates the flow rate.

Figure 7-5 Flow Calibration dialog box

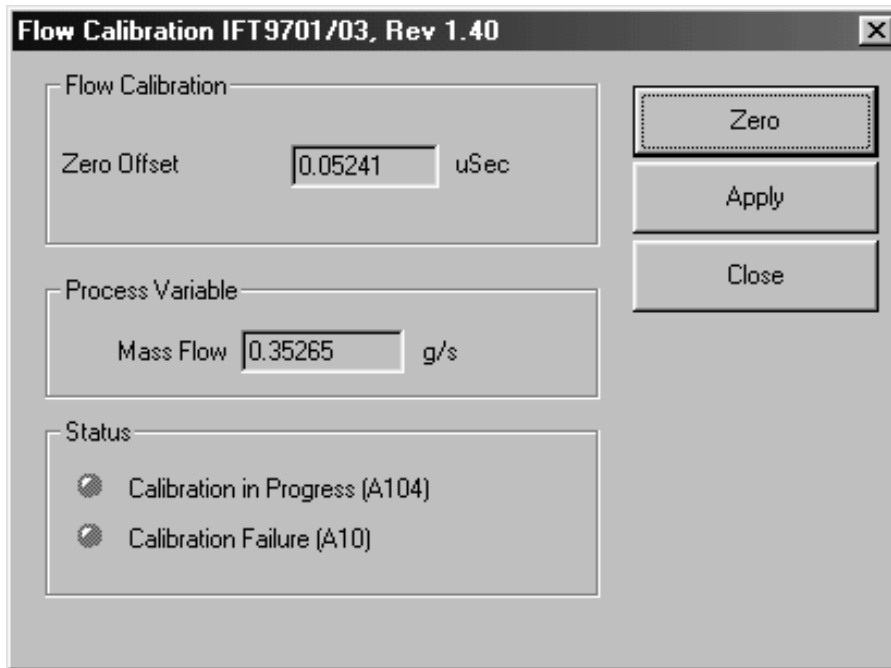

Diagnosing zeroing failure

If zeroing fails:

- The Calibration Failure status light turns red.
- The meter's diagnostic LED blinks ON four times per second.
- The flowmeter produces fault outputs.
- The message "ELECO" blinks on and off in the meter's optional display.

The most common sources of zeroing failure are:

- Flow of fluid through meter during zeroing
- Partially empty flow tubes
- An improperly mounted meter

Re-zero the flowmeter after correcting the problem, or cycle power to the meter to abort the entire zeroing procedure and return to the previously established zero.

7.3.2 Flow calibration procedure

Flow calibration involves adjusting the flow calibration factor so it accurately represents the sensitivity of the flowmeter to mass flow. Performing the flow calibration procedure in the field is optional.

Flow calibration is performed by running a batch of fluid through the meter, weighing the fluid, then using the Totalizer Control window to compare the weighed amount with the amount of fluid measured by the flowmeter. The accuracy of the scale used for weighing the fluid will determine the accuracy of the flow calibration. Use a scale that is highly accurate.

Configuration with ProLink II Software *continued*

Use a mass flow unit during the calibration procedure. If the application requires volume flow measurement, choose a mass flow unit for the flow calibration, then choose a volume flow unit for the application.

To calculate the flow calibration factor:

1. Configure the transmitter to use a mass flow measurement unit (see Section 7.2.2).
2. In the Flow panel (depicted in Figure 7-2), enter the flowmeter's 8-digit flow calibration factor into the Flow Cal text box. The flow calibration factor can be found on the flowmeter's serial number tag, or on the certificate that is shipped with the sensor.
3. Zero the flowmeter (see Section 7.3.1).
4. With flow through the meter *completely* stopped, from the ProLink menu, click on Totalizer Control. The Totalizer Control window is displayed, as depicted in Figure 7-6.

Figure 7-6 Totalizer Control window

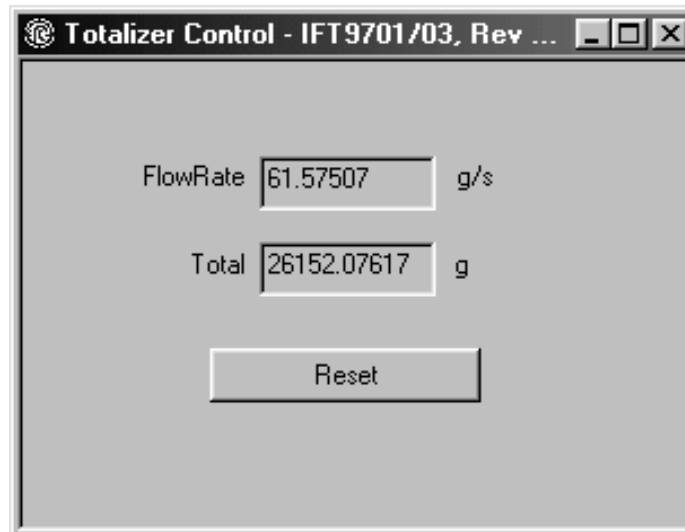

5. Click the Reset button to reset the internal totalizer to zero.

- Run three batches of fluid, resetting the scale and totalizer between batches. For each batch, record the weights indicated by the scale and the totalizer.

	Weight_{scale}	Weight_{totalizer}
First batch	_____	_____
Second batch	_____	_____
Third batch	_____	_____
Total	_____	_____

- Divide *Total Weight_{scale}* by *Total Weight_{totalizer}*. This is the mass-flow meter factor. Record the meter factor.

Mass-flow meter factor _____

- Multiply the meter factor from Step 7 by the first five digits of the current flow calibration factor. This is the first five digits of the new flow calibration factor.

First 5 digits of new FloCal factor _____

- Enter the new flow calibration factor into the Flow Cal text box in the Flow panel. The complete flow calibration factor should have eight digits and two decimal points:
 - Enter the value from Step 8 as the first five digits and first decimal point.
 - For the last three digits and second decimal point, enter the last three digits and second decimal point from the flow calibration factor entered in Step 2.
- To verify the accuracy of the new flow calibration factor, repeat Step 6. The amount of fluid indicated in the Totalizer Control dialog box should equal the weighed amount of fluid in the batch, within accuracy specifications provided by Micro Motion for the flowmeter.

7.4 Characterization

Characterization involves entering a density calibration factor that accurately represents the sensitivity of the flowmeter to fluid density.

To characterize the flowmeter for density measurement:

- From the ProLink menu, click on Configuration.
- In the Configuration window, click on the Density tab. The Density panel, shown in Figure 7-7, is displayed.
- Enter the 14-character density calibration factor (including the decimal point) into the Density Cal text box. The calibration factor can be found on the flowmeter's serial number tag, or on the certificate that is shipped with the meter.

Figure 7-7 Configuration window – Density panel

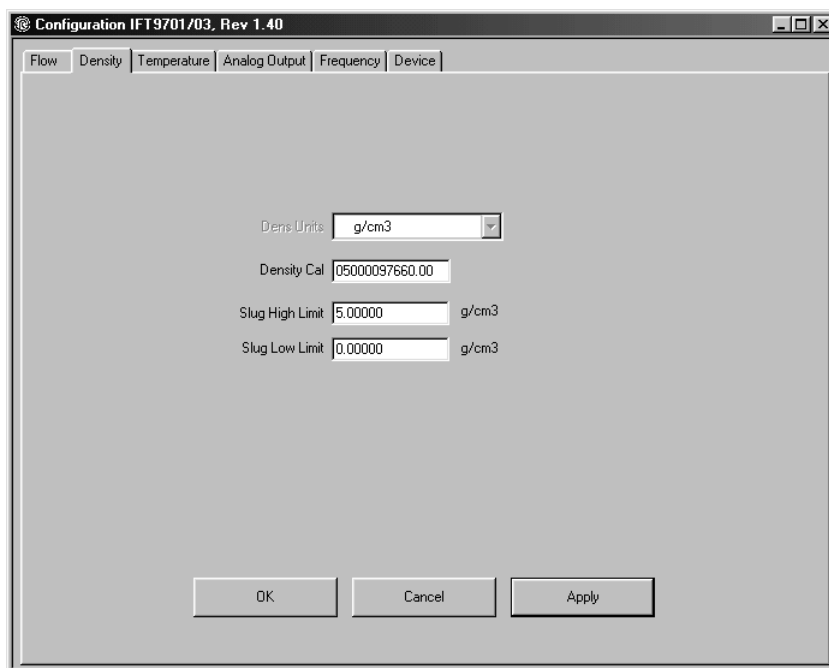

Chapter 8

Troubleshooting

8.1 Customer service

For assistance, phone the Micro Motion Customer Service Department. Phone numbers are listed on the title page of this manual.

8.2 General guidelines

Troubleshooting a Micro Motion flowmeter is performed in two parts:

- Tests of wiring circuit integrity.
- Observation of the transmitter's diagnostic tools, which include the diagnostic LED, fault output levels, and optional LCD.

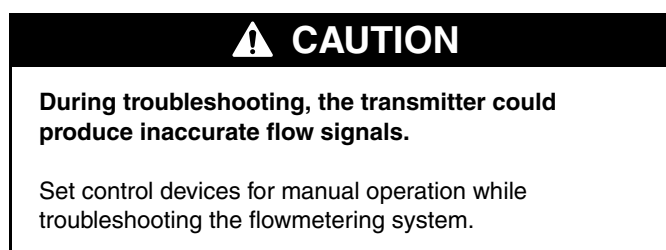

Follow these general guidelines while troubleshooting a Micro Motion flowmeter:

- Before beginning the diagnostic process, become familiar with this instruction manual and with the instruction manual for the sensor.
- While troubleshooting a problem, leave the sensor in place, if possible. Problems may result from the specific environment in which the sensor operates.
- Check all signals under both flow and no-flow conditions. This procedure will minimize the possibility of overlooking some causes or symptoms.

8.3 Transmitter diagnostic tools

In some situations, troubleshooting requires use of the transmitter's diagnostic tools, which include the diagnostic LED, fault output levels, and optional LCD.

8.3.1 Diagnostic LED

The diagnostic LED indicates the operating condition of the transmitter. Table 8-1 explains the operating conditions indicated by the diagnostic LED. Figure 8-1 shows the location of the LED in the intrinsically safe wiring compartment.

Figure 8-1 Transmitter terminals and diagnostic LED

Power supply

- If transmitter fails to produce outputs, check for reversed polarity
- Make sure actual power supply matches power supply shown on label
- AC power applied to DC transmitter will damage transmitter
- Power-supply fuses are not replaceable

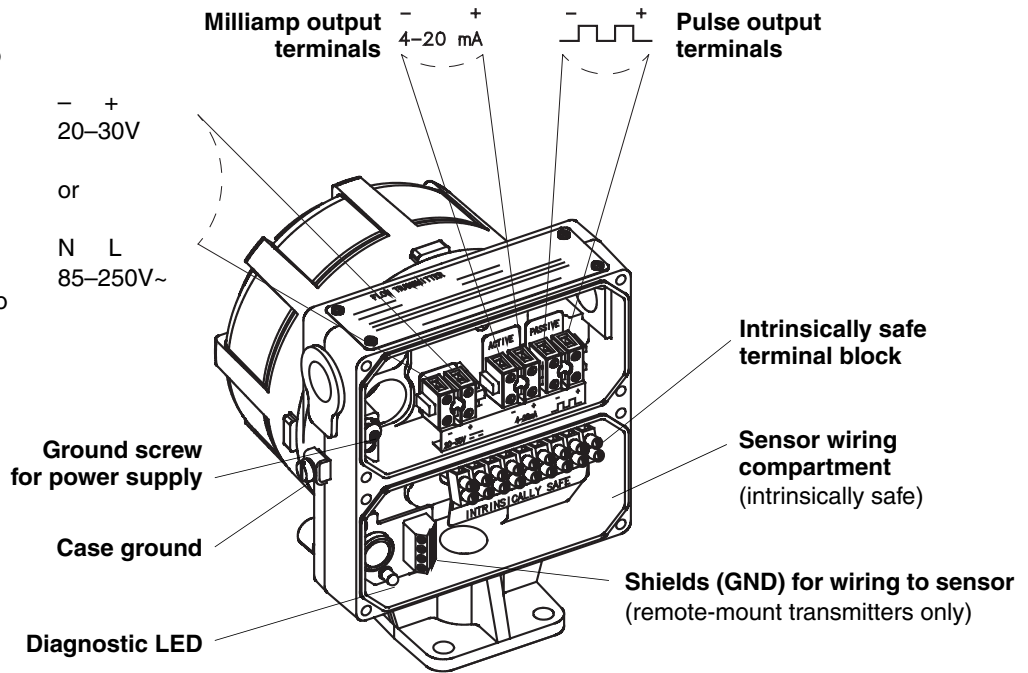

8.3.2 Optional LCD

Except for ATEX Zone 1 areas, the transmitter is available with an optional LCD. The 5-digit LCD is on the cover of the field wiring compartment, and indicates the mass or volume flow rate or the operating condition of the flowmeter. Table 8-2 explains the operating conditions indicated by the LCD.

8.3.3 Fault outputs

The transmitter produces downscale or upscale outputs to indicate a fault.

- Downscale: The milliamp output goes to 2 mA; the pulse output goes to 0 Hz.
- Upscale: The milliamp output goes to 22 mA; the pulse output goes to 7200 Hz.

Unless otherwise specified on the order, jumpers are set so the transmitter generates downscale fault outputs. To change jumper settings for fault outputs, see Section 2.3.

Table 8-1 Normal conditions indicated by LED

Diagnostic LED does this:	Condition
Blinks ON once per second (25% ON, 75% OFF)	Normal operation
Remains ON	Startup and initialization, zero in progress, transmitter hardware failure
Blinks OFF once per second (75% ON, 25% OFF)	Slug flow (density below or above user-defined limits)
Blinks ON 4 times per second	Fault condition
Remains OFF	Power-supply failure, transmitter hardware failure

Table 8-2 Conditions indicated by optional LCD

Optional LCD reads:	Condition
Mass or volume flow rate (such as "100.00")	Normal operation
"OL0"	Flow rate has exceeded upper limit of display
" 88.8.8.0"	Startup and initialization
"ZERO0"	Zero in progress
"SLUG0"	Slug flow (density below or above user-defined limits)
"ELEC0"	Transmitter hardware failure, zero failure
"SENS0"	Sensor failure, faulty cable, process over range, density above or below transmitter limits
Remains OFF	Power supply failure

8.4 Power supply

If power supply wiring is installed incorrectly, or the flowmeter is improperly grounded, the meter will not operate properly. Follow these steps to check power supply wiring and grounding:

1. If a switch was installed in the power supply line, be sure the switch is in the ON position.
2. Check the power supply voltage, and make sure it matches the voltage listed on the label in the flowmeter's power supply wiring compartment. See Figure 8-2.
3. Turn power supply OFF.

⚠ WARNING

Line voltage can cause electric shock or flowmeter damage.

Disconnect power before accessing power supply terminals.

4. At the terminals indicated in Figure 8-2, make sure wires are secured tightly and making good connections. Make sure no bare wires remain exposed.
5. Wiring must be 20 AWG (0,5 mm²) to 16 AWG (1,5 mm²) wire.
6. Maximum wire lengths for a DC power supply are as follows:

Power-supply wire size	Maximum length
16 AWG (1,5 mm ²)	1500 feet (450 meters)
18 AWG (0,75 mm ²)	1000 feet (300 meters)
20 AWG (0,5 mm ²)	600 feet (200 meters)

Figure 8-2 Power supply connections

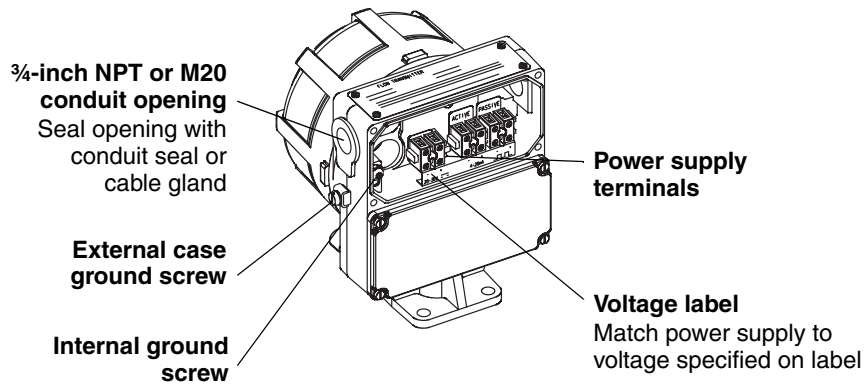

7. Make sure the power cable is not installed in the same conduit or cable tray as output wiring.
8. Make sure the meter is properly grounded. If national standards are not in effect, adhere to this standard:
 - For grounding, use copper wire, 14 AWG (2,5 mm²) or larger wire size.
 - Either the internal ground screw or external case ground screw may be used as required by local policy or code.
 - Keep all ground leads as short as possible.
 - Flowmeter must be grounded with less than 1 ohm impedance.
 - Connect power-supply ground directly to earth.

The flowmeter does not have replaceable fuses for the power supply.

8.5 Wiring

For detailed wiring instructions, refer to Chapters 3 and 4.

Wiring problems are often incorrectly diagnosed as a faulty sensor. At initial startup of the transmitter, always check the following:

1. Proper cabling, and use of shielded pairs
2. Proper wire termination
 - Wires on correct terminals.
 - Wires making good connections with the terminal strip.
 - Wires making good connections at the receiving device.
 - Wires making good connections at the sensor terminals. Table 8-3 lists terminal designations for Micro Motion sensors.

Table 8-3 Sensor terminal designations

Terminal number	Wire color	Function
1	Brown	Drive +
2	Red	Drive –
3	Orange	Temperature –
4	Yellow	Temperature lead length compensator
5	Green	Left pickoff +
6	Blue	Right pickoff +
7	Violet	Temperature +
8	Gray	Right pickoff –
9	White	Left pickoff –

To check integrity of sensor wiring circuits:

1. Disconnect the transmitter's power supply.
2. Disconnect sensor wiring from the transmitter's intrinsically safe terminal block in the sensor wiring compartment. See Figure 8-1.
3. Use a DMM to measure resistance between wire pairs, as indicated in Table 8-4.
4. If the transmitter is remotely mounted from the sensor, repeat the measurements at the terminal block in the sensor junction box to distinguish cable failure from sensor failure.

Table 8-4 Normal resistance and voltage ranges for flowmeter circuits

Notes

- Temperature sensor value increases 0.38675 ohms per °C increase in temperature.
- Nominal resistance values will vary 40% per 100 °C. However, confirming an open coil or shorted coil is more important than any slight deviation from the resistance values presented below.
- Resistance across terminals 6 and 8 (right pickoff) should be within 10% of resistance across terminals 5 and 9 (left pickoff).
- Resistance values depend on the sensor model and date of manufacture.

Circuit	Wire colors	Sensor terminals	Nominal resistance range
Drive coil	Red to brown	1 to 2	8 to 2650Ω
Left pickoff	Green to white	5 to 9	15.9 to 300Ω
Right pickoff	Blue to gray	6 to 8	15.9 to 300Ω
Temperature sensor	Orange to violet	3 to 7	100Ω at 0°C + 0.38675Ω/°C
Lead length compensator	Yellow to violet	4 to 7	100Ω at 0°C + 0.38675Ω/°C

8.6 Over range and sensor failure conditions

If a sensor failure occurs, if the flowmeter cable is faulty, or if flow, temperature, or density goes outside the sensor limits, all the following occur:

- The transmitter produces fault outputs.
- The diagnostic LED blinks ON 4 times per second.
- The optional LCD reads “SENS0”.

Troubleshooting *continued*

If the transmitter indicates an over range or sensor failure condition, follow these steps:

1. Isolate the transmitter from devices that use transmitter outputs to control the flow loop.
2. Refer to Table 8-5 to diagnose the problem.
3. If troubleshooting fails to reveal why over range and/or sensor failure messages have appeared, phone Micro Motion Customer Service. Phone numbers are listed on the title page of this manual.

Table 8-5 Troubleshooting over range and sensor failure conditions

Digital multimeter (DMM)	Cause(s)	Corrective action(s)
<ul style="list-style-type: none"> • Open or short from red to brown at transmitter • Open or short from red to brown at sensor 	<ul style="list-style-type: none"> • Faulty cable • Faulty drive coil in sensor • Moisture in sensor case or junction box 	<ul style="list-style-type: none"> • If open or short at transmitter terminals, check cable • If open or short at sensor junction box, return sensor to factory • Replace conduit and/or conduit seals • Repair cable
<ul style="list-style-type: none"> • Open or short from green to white at transmitter • Open or short from green to white at sensor 	<ul style="list-style-type: none"> • Faulty cable • Faulty left pickoff in sensor • Moisture in sensor case or junction box 	<ul style="list-style-type: none"> • Repair cable
<ul style="list-style-type: none"> • Open or short from blue to gray at transmitter • Open or short from blue to gray at sensor 	<ul style="list-style-type: none"> • Faulty cable • Faulty right pickoff in sensor • Moisture in sensor case or junction box 	<ul style="list-style-type: none"> • Repair cable
<ul style="list-style-type: none"> • No open circuits • No short circuits 	<ul style="list-style-type: none"> • Transmitter cannot calculate offset of flow signal 	<ul style="list-style-type: none"> • Ensure that the sensor is filled with fluid • Eliminate noise, then rezero • Completely shut off flow, then rezero
	<ul style="list-style-type: none"> • Transmitter cannot calculate flow rate 	<ul style="list-style-type: none"> • Eliminate pipe stress, vibration, or mechanical noise
	<ul style="list-style-type: none"> • Inappropriate density factor • Density < 0.200 g/cc or > 2.000 g/cc, volume flow is being measured • Density > 2.000 g/cc, mass flow is being measured • Erratic process density has caused flow tubes to stop vibrating • Plugged flow tube • Transmitter cannot calculate density 	<ul style="list-style-type: none"> • Characterize density values for sensor • Monitor density • Bring density within sensor limit • Purge flow tubes • Eliminate pipe stress, vibration, or mechanical noise
<ul style="list-style-type: none"> • Open or short from yellow to orange at transmitter • Open or short from yellow to orange at sensor 	<ul style="list-style-type: none"> • Temperature outside sensor limit • Faulty cable • Faulty lead length compensator 	<ul style="list-style-type: none"> • Bring temperature within sensor limit • Monitor temperature • If open or short at transmitter terminals, check cable
<ul style="list-style-type: none"> • Open or short from violet to yellow at transmitter • Open or short from violet to yellow at sensor 	<ul style="list-style-type: none"> • Faulty cable • Faulty RTD in sensor 	<ul style="list-style-type: none"> • If open or short at sensor junction box, return sensor to factory

8.7 Slug flow

Programmed slug flow limits minimize inaccurate measurement caused by significant quantities (slugs) of gas during liquid flow measurement or slugs of liquid during gas flow measurement. Such conditions adversely affect sensor performance by causing erratic vibration of the flow tubes, which in turn causes the transmitter to produce inaccurate flow signals.

A slug flow condition causes the following to occur:

- The pulse output goes to 0 Hz.
- The milliamp output goes to the level that represents zero flow.
- The diagnostic LED blinks OFF once per second.
- The optional LCD reads “SLUG0”.

The flowmeter resumes normal operation when density stabilizes within the programmed slug flow limits.

8.8 Transmitter failure

If the transmitter electronics fail, all the following occur:

- The transmitter produces fault outputs.
- The diagnostic LED blinks ON 4 times per second.
- The optional LCD reads “ELEC0”.

If a transmitter failure is indicated, phone the Micro Motion Customer Service Department. Phone numbers are listed on the title page of this manual.

8.9 Digital diagnostic messages

The transmitter provides a large number of diagnostic messages, which can be viewed on the display of the HART Communicator or in the Status window of the ProLink II software program.

Appendix A

IFT9701 Specifications

A.1 Performance specifications

For performance specifications, refer to the documentation for your sensor.

A.2 Functional specifications

A.2.1 Output signals

Milliamp (active)

- 4–20 mA output represents mass flow or volume flow
- Sensor size determines minimum and maximum spans. Recommended minimum span (% of nominal flow range):
 - ELITE sensors: 2.5%
 - F-Series sensors: 10%
 - D and DL sensors: 10%
- Load limit is 600 ohms
- Internally powered (active)
- Isolated to ± 500 VDC from all other outputs and earth ground
- Out-of-range capability is 3.8 or 20.5 mA

Pulse (passive)

- Pulse output represents mass or volume flow
- Externally powered (passive), requires pull-up resistor to 5–30 VDC power supply
- Minimum resistance is 500 ohms at 5 V, 3 kohms at 30 V
- Galvanically isolated to ± 500 VDC
- Out-of-range capability to 7200 Hz
- Voltage in on state is less than 1 V
- Below 1 Hz, the pulse width will be 500 ms; at all pulse frequencies between 1 Hz and 7200 Hz, the pulse width is half the pulse period

Communication

- HART protocol-compatible Bell 202 digital signal is superimposed on 4–20 mA analog signal, and available for host system interface
- Frequency 1.2 and 2.2 kHz, amplitude 0.5 mA peak-to-peak, baud rate 1200 baud
- Requires 250 to 600 ohms load resistance

A.2.2 Local display (optional)

5-digit, alphanumeric, liquid crystal display (LCD) installed on the field-wiring compartment cover. The LCD shows flow rate, and indicates slug flow, flowmeter zeroing in progress, and electronic faults.

Note: Not available for ATEX Zone 1 applications.

A.2.3 Low-flow cutoff

Flow rate below cutoff causes outputs to default to level that indicates zero flow and totalizer stops counting

A.2.4 Slug-flow inhibit

When transmitter senses density outside user-selected limits, outputs default to levels indicating zero flow and totalizer stops counting

A.2.5 Damping

User-selected time constant of 0.1, 0.2, 0.4, 0.8, 1.6, 3.2, 6.4, or 12.8 seconds

A.2.6 Fault indication

Fault condition can be indicated by user-selected downscale (2 mA, 0 Hz) or upscale (22 mA, 7200 Hz) output levels, Bell 202 communications, and optional display

A.2.7 Output testing

Current source

Can output a specified current between 2 and 22 mA

Frequency source

Can output a specified frequency between 0.01 and 1200 Hz

A.2.8 Power supply options

85 to 250 VAC

- 45 to 65 Hz, 9 watts maximum power dissipation
- 20 VA maximum apparent line power
- Fused at 250 V/0.4 A IEC delayed, nonreplaceable
- Meets low-voltage directive 73/23/EEC

20 to 30 VDC

- 6 watts typical, 14 watts maximum
- Fused at 60 V/1.8 A Trip
- Minimum startup voltage is 16 V at transmitter terminals
- Maximum total resistance for wiring is 13 ohms
- At startup, transmitter power source must provide a minimum of 0.7 amp of short-term current

A.3 Environmental limits

A.3.1 Temperature

Operating

See *Process fluid vs. ambient temperature*, below

Optional local display may become difficult to read below +14 °F (–10 °C).

Storage

–40 to +185 °F (–40 to +85 °C) without optional LCD

–4 to +58 °F (–20 to +70 °C) with optional LCD

A.3.2 Process fluid temperature limits

Integrally mounted transmitter

–40 to +257 °F (–40 to +125 °C)

See *Process fluid vs. ambient temperature*, below.

Remotely mounted transmitter

Refer to temperature limits for sensor.

Process fluid vs. ambient temperature

At their upper limits, process fluid temperature and ambient temperature restrict each other. The graphs provided below define the maximum recommended process fluid temperature based on maximum expected ambient temperature.

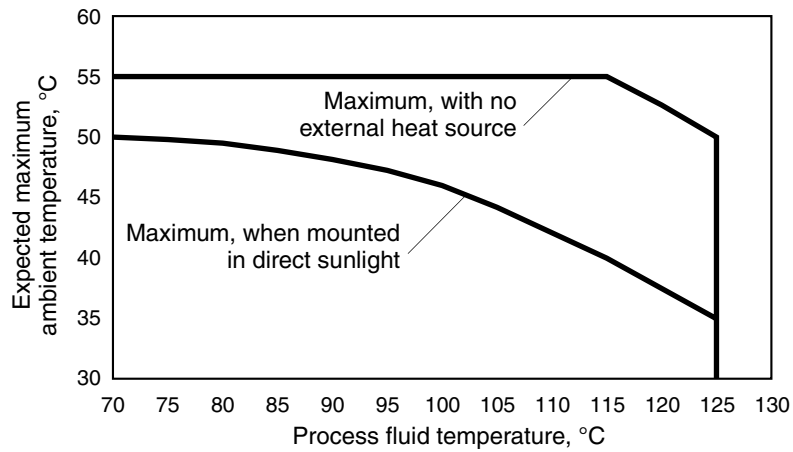
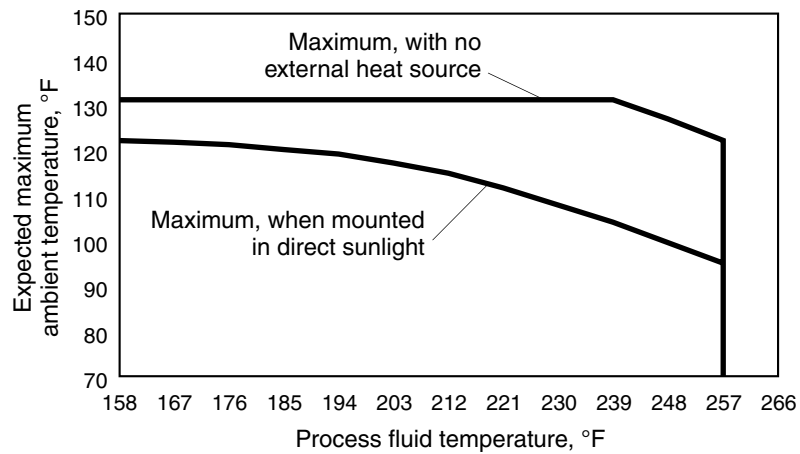

A.3.3 Humidity limits

5 to 95% non-condensing

A.3.4 Vibration limits

Meets IEC 68.2.6, 2 g, endurance sweep, 10 to 2000 Hz, 50 sweep cycles

A.4 Density limits

- 0.2 to 2.0 g/cc (200 to 2000 kg/m³) for volume flow
- 0.0 to 2.0 g/cc (0 to 2000 kg/m³) for mass flow

A.5 Environmental effects

Transmitters meet the requirements of the EMC directive 89/336/EEC per EN 61326 Industrial (April 1997) when operated at nominal rated flow measurement range. For specific EMC effects within the EC, the Technical EMC file may be reviewed at Micro Motion Veenendaal.

To meet the above specifications, the transmitter must be installed with an approved Micro Motion sensor, and the sensor cable must be doubly shielded with full-contact glands, or installed in continuous, fully bonded metallic conduit. The transmitter and sensor must be directly connected to a low-impedance (less than 1 ohm) earth ground. Transmitter outputs must be standard twisted-pair, shielded instrument wire.

A.6 Ambient temperature effect on milliamp output

±0.005% of flow rate per °C deviation from output trim temperature

A.7 Shipping weight

- Transmitter only: 12.5 lb (5,7 kg)
- For flowmeter weights, see sensor specifications

A.8 Hazardous area classifications

For approvals that apply to an individual transmitter, see the hazardous area approvals tag attached to the transmitter.

ATEX

When ordered for installation in a Zone 1 (hazardous) area, EEx de[ib] IIB/IIC T6

Otherwise, [EEx ib] IIB/IIC

UL and CSA

Class I, Division 2, Groups A,B,C, and D

Class II, Division 2, Groups F and G

Appendix B

HART Communicator Menu Trees

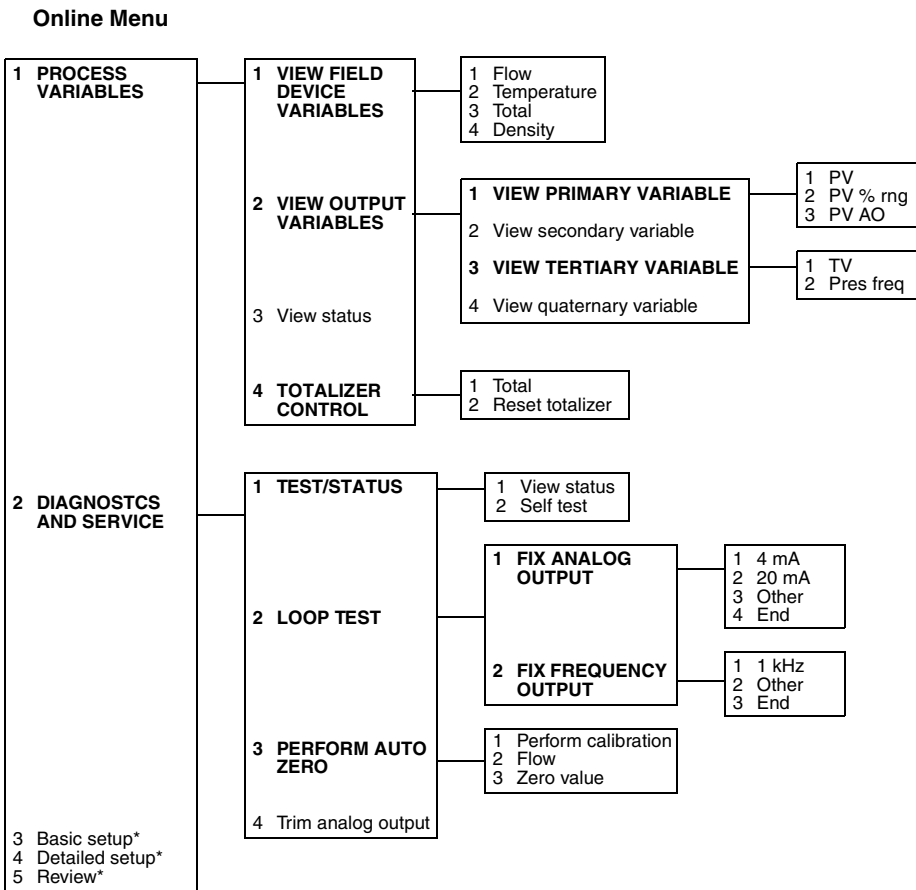

*See following page

Online Menu

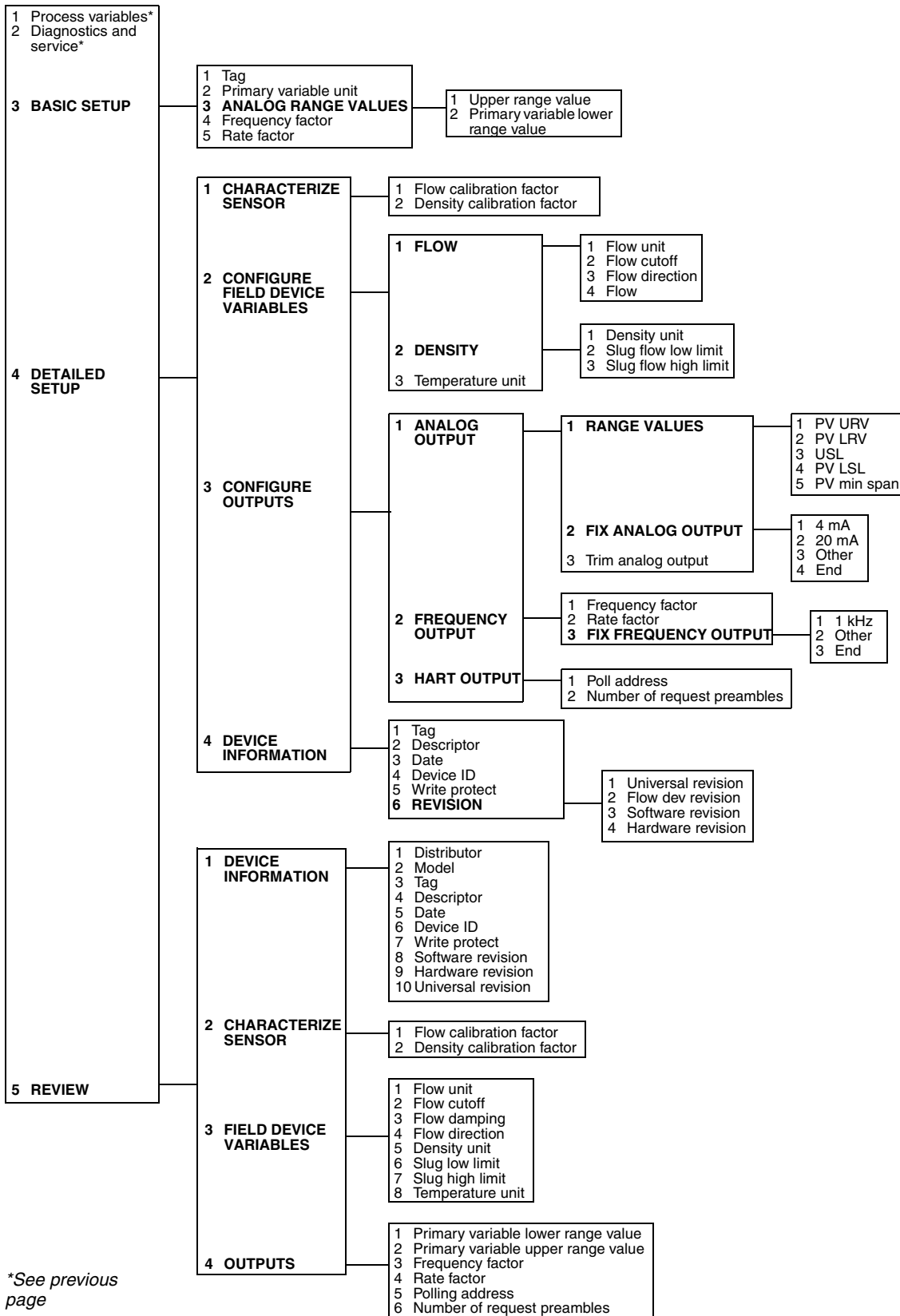

*See previous page

Appendix C

Installing the Optional Display

⚠ WARNING

Line voltage can cause electric shock or transmitter damage.

Disconnect input power before installing display.

To install the optional display, follow these steps:

1. Make sure you are wearing an anti-static wrist strap.
2. Disconnect input power to the flowmeter.
3. Loosen the captive screws that hold the field wiring compartment cover in place, then remove the cover.
4. A pair of wires and a connector, which connect to the display, are tucked behind the label for the power supply wiring terminals in the field wiring compartment. Carefully move the wire pair and connector from behind the label, as shown in the illustration below.

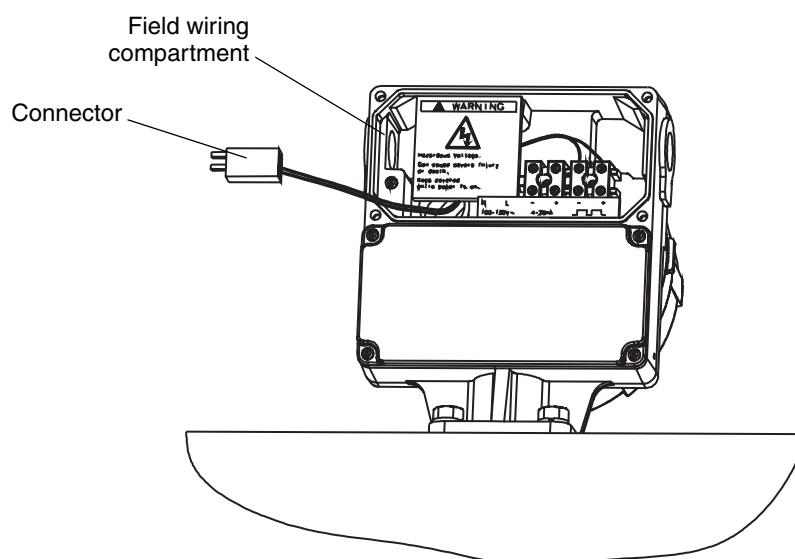

5. On the back of the display is a spring-loaded retaining clip, which is held in place by a screw and washer. Because the retaining clip springs open, exercise care to avoid losing the screw and washer as they are removed. Remove the screw and washer.
6. Plug the male connector that is attached to the back of the display into the female connector that is attached to the wire pair.
7. Slip the retaining clip over the wire pair.

Installing the Optional Display *continued*

- Put the retaining clip, washer, and screw in place on the back of the display. See illustration, below.

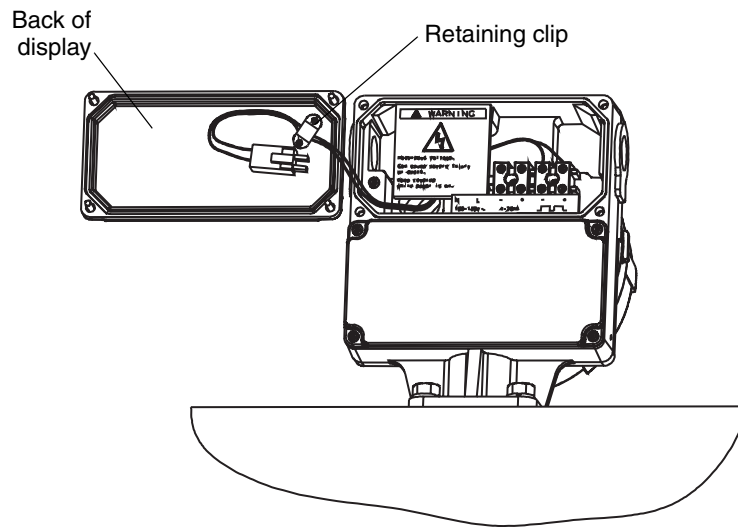

- Put the display in place on the field wiring compartment. Tighten the screws evenly until the display assembly is flush against the flowmeter housing and is completely sealed.

⚠ CAUTION

Failure to seal flowmeter housing could cause a short circuit, which would result in measurement error or flowmeter failure.

To avoid risk of condensation or excessive moisture entering the flowmeter housing, ensure integrity of gaskets, and fully tighten all housing covers.

Appendix D

Return Policy

D.1 General guidelines

Micro Motion procedures must be followed when returning equipment. These procedures ensure legal compliance with government transportation agencies and help provide a safe working environment for Micro Motion employees. Failure to follow Micro Motion procedures will result in your equipment being refused delivery.

Information on return procedures and forms is available on our Web support system at www.micromotion.com, or by phoning the Micro Motion Customer Service Department. Contact information is provided on the title page of this manual.

D.2 New and unused equipment

Only equipment that has not been removed from the original shipping package will be considered new and unused. New and unused equipment includes sensors, transmitters, or peripheral devices which:

- Were shipped as requested by the customer but are not needed, or
- Were shipped incorrectly by Micro Motion.

New and unused equipment requires a completed Return Materials Authorization form.

D.3 Used equipment

All equipment that is not classified as new and unused is considered used. This equipment must be completely decontaminated and cleaned before being returned.

Used equipment must be accompanied by a completed Return Materials Authorization form and a Decontamination Statement for all process fluids that have been in contact with the equipment. If a Decontamination Statement cannot be completed (e.g., for food-grade process fluids), you must include a statement certifying decontamination and documenting all foreign substances that have come in contact with the equipment.

Index

A

- About this manual 1
- Accessibility, reliability and safety 5–7
- Agency approvals
 - approved areas 69
 - hazardous area installation 5
- Approvals tag 7
- Armored cable
 - bend radii 15
 - cable types 14
 - conduit requirements 15
 - temperature limits 15
- ATEX
 - approved areas 69
 - hazardous area installation 5
 - Zone 1 installation 7

B

- Before you begin 1–3
- Bell 202
 - multidrop network 23
 - network wiring 23

C

- Cable
 - bend radii 14, 15
 - conduit
 - installation guidelines 16
 - requirements 15
 - gland
 - installation guidelines 16
 - sensor wiring 16
 - temperature limits 15
 - types 14
- Calibration
 - flowmeter startup 32
 - HART Communicator 35
 - ProLink II software 45
- CE
 - cable types 14
 - environmental effects 68
 - power supply wiring 20
- Characterization 32
- Circuit board compartment
 - jumper settings 10

- Conduit openings
 - orientation and mounting 6
- Configuration
 - flowmeter startup 32
 - HART Communicator 35
 - damping 38
 - density characterization 44
 - flow calibration 42–44
 - flow cutoff 38
 - flow direction 39
 - HART tag 36
 - measurement units 36–38
 - milliamp output 40
 - overview 35
 - process variable measurement 36
 - pulse output 40
 - zero failure 42
 - zeroing 41–42
 - ProLink II software 45
 - damping 49
 - density characterization 55
 - flow calibration 53–55
 - flow cutoff 48
 - flow direction 48
 - HART tag 46
 - measurement units 47
 - milliamp output 50
 - overview 45
 - process variable measurement 47
 - pulse output 51
 - zero failure 53
 - zeroing 51–53
- CSA
 - approved areas 69
 - hazardous area installation 5
- Customer service 57
- Cutoff
 - configuration
 - HART Communicator 38
 - ProLink II software 48
- D
 - Damping 66
 - configuration
 - HART Communicator 38
 - ProLink II software 49

Index *continued*

Definitions 2

Density

calibration factor

HART Communicator 44

ProLink II software 55

Diagnostic LED

startup 30

troubleshooting with 57

Display

diagnostic messages 63

installing 73–74

specifications 65

startup 30

troubleshooting with 58

E

Environmental effects 68

F

Fault outputs

jumper settings 9

specifications 66

troubleshooting with 58

Flow calibration factor

HART Communicator 42

ProLink II software 53

Flow direction

configuration

HART Communicator 39

ProLink II software 48

Flowmeter

components 2

zeroing 31–32

Fuses 60, 66

G

Getting started 5–10

Grounding

power supply 20

H

HART

milliamp output 22

network wiring 23

HART Communicator

configuration 35

menu trees 71

output specifications 65

wiring connections 24

HART protocol

multidrop network 23

Humidity limits

installation 6

specifications 68

I

IFT9701 transmitter

components 2

failure condition 63

mounting 6

orientation 6

specifications 65

Initialization 30

Intrinsically safe installations

wiring guidelines 5

J

Jacketed cable

bend radii 14

cable types 14

conduit requirements 15

temperature limits 15

Jumper settings

fault outputs 9

security 9

L

Low-flow cutoff 66

M

Measurement units

HART Communicator 37

ProLink II software 48

Milliamp output 22

HART Communicator 24

ProLink II software 24

specifications 65, 66

temperature effect 69

wiring 22

Mounting 11–17

cable

conduit 15, 16

gland 16

temperature limits 15

types 14

flat-surface mounting 11

orientation 6

pole mounting 11

sensor terminals 17

wiring 16

N

NAMUR standard 22

New equipment returns 75

Index continued**O**

- Orientation 6
- Output wiring 21–23
 - HART Communicator 24
 - HART network 23
 - milliamp output 22
 - ProLink II software 24
- Outputs
 - configuration
 - HART Communicator 40
 - ProLink II software 50, 51
 - NAMUR standard 22
- Over range condition 61

P

- Power supply
 - specifications 66
 - troubleshooting 59
 - wiring 19
- ProLink II software
 - configuration 45
 - output specifications 65
 - wiring connections 24
- Pulse counter wiring 25
- Pulse output
 - specifications 65, 66

R

- Reliability, safety and accessibility 5–7
- Return policy 75

S

- Safety, reliability and accessibility 5–7
- Security
 - jumper settings 9
- Sensor
 - compatibility 2
 - definition 2
 - failure condition 61
- Series 3000 platform
 - pulse output 25
- Shielded cable
 - bend radii 15
 - cable types 14
 - conduit requirements 15
 - temperature limits 15
- Slug flow
 - specifications 66
 - troubleshooting 62
- Specifications 65
 - agency approvals 69
 - damping 66

- density limits 68
- environmental effects 68
- fault outputs 66
- humidity limits 68
- low-flow cutoff 66
- output signals 65
- output testing 66
- power supply 66
- slug-flow inhibit 66
- temperature
 - effects 69
 - process fluid limits 67
- vibration limits 68
- weight 69
- Startup 29
 - calibration 32
 - diagnostic LED 30
 - display 30
 - initialization 30
 - operating mode 30
 - startup mode 30
 - zeroing 31–32
 - zeroing failure 32

T

- Tags 7
- Temperature
 - installation 6
 - specifications
 - effects 69
 - process fluid limits 67
- Transmitter
 - definition 2
- Troubleshooting 57
 - customer service 57
 - diagnostic messages 63
 - diagnostic tools 57
 - diagnostic LED 57, 58
 - display 58
 - fault outputs 58
 - general guidelines 57
 - over range condition 61
 - power supply 59
 - sensor failure 61
 - slug flow 62
 - transmitter failure 63
 - wiring 60–61
 - resistance 61
 - voltage 61

Index *continued*

U

UL

approved areas 69

hazardous area installation 5

Used equipment returns 75

V

Vibration limits 68

installation 6

W

Wiring 19

CE requirement 20

general guidelines 19

grounding 20

outputs 21–23

HART Communicator 24

HART network 23

milliamp output 22

ProLink II software 24

power supply 19, 20

resistance 61

sensor

connections 16

terminal designations 17

troubleshooting 60–61

voltage 61

Z

Zeroing 31–32

failure

HART Communicator 42

ProLink II software 53

startup 32

HART Communicator 41–42

ProLink II software 51–53

©2004, Micro Motion, Inc. All rights reserved. P/N 3100572, Rev. E



For the latest Micro Motion product specifications, view the PRODUCTS section of our Web site at www.micromotion.com

Micro Motion Inc. USA
Worldwide Headquarters

7070 Winchester Circle
Boulder, Colorado 80301
T (303) 530-8400
(800) 522-6277
F (303) 530-8459

Micro Motion Europe

Emerson Process Management
Wiltonstraat 30
3905 KW Veenendaal
The Netherlands
T +31 (0) 318 495 670
F +31 (0) 318 495 689

Micro Motion Asia

Emerson Process Management
1 Pandan Crescent
Singapore 128461
Republic of Singapore
T (65) 6777-8211
F (65) 6770-8003

Micro Motion United Kingdom

Emerson Process Management Limited
Horsfield Way
Bredbury Industrial Estate
Stockport SK6 2SU U.K.
T 0800 966 180
F 0800 966 181

Micro Motion Japan

Emerson Process Management
Shinagawa NF Bldg. 5F
1-2-5, Higashi Shinagawa
Shinagawa-ku
Tokyo 140-0002 Japan
T (81) 3 5769-6803
F (81) 3 5769-6843

