

NADY AUDIO

OWNER'S MANUAL

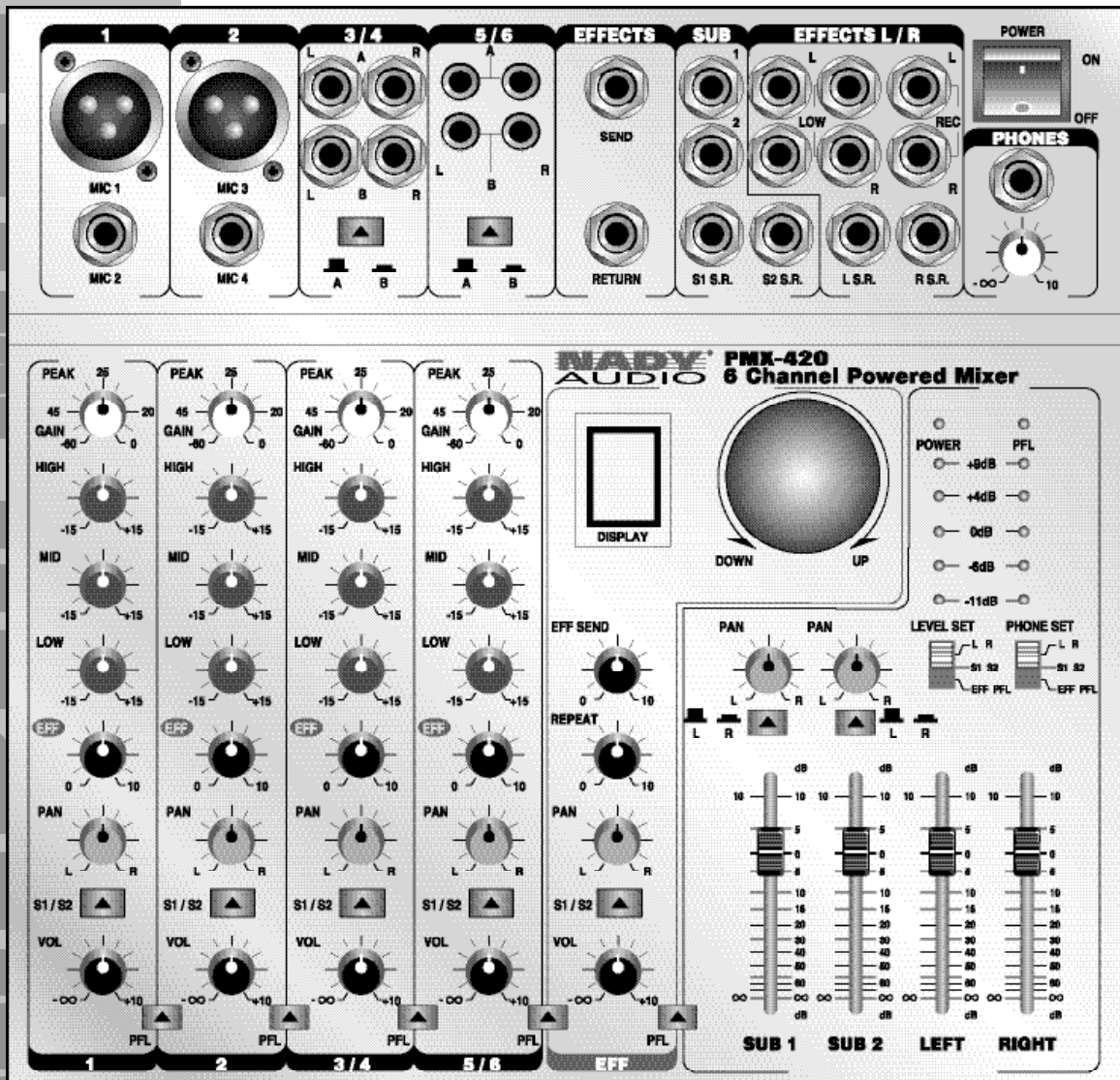

PMX-420

6 Channel Powered Console Mixer

PMX-420

6 Channel Powered Console Mixer



NADY[®]
AUDIO

Congratulations on your choice of the NADY AUDIO PMX-420 powered console mixer — you have purchased one of the finest powered mixing units on the market today. This unit was developed using the expertise of professional sound engineers and working musicians. You will find that your new PMX-420 powered mixer has superior performance and greater flexibility than any other powered mixer in its price range. Please read this manual carefully to get the most out of your new unit. Thanks for selecting NADY AUDIO as your choice in powered mixers

FEATURES

- This amazingly compact 6-channel powered mixer can pump out 420W RMS, complete with Echo Effects and Submixes, while capable of handling 11 total inputs simultaneously!
- 2 Mono channels each with balanced XLR Mic and 1/4" TRS line inputs and 2 Stereo channels with input A or B selector switch for each channel, Effects Return and Submix 1 & 2 Return with dedicated Volume/Pan for a total of 11 simultaneous inputs
- Power Output – 2 x 210W RMS @ 4 ohms (1% THD) with both channels driven. Advanced amplifier design features include fan cooling, short circuit protection, speaker DC protection circuits, clip indicators for utmost safety and reliability and power ON/OFF anti-thump circuit for quietest operation
- Stereo L-R Master Mix and S1-2 Group Submix buses, with 4 master faders and submix to main enable switch and Pan controls
- Built-in Echo Effects 32-bit DSP emulates plate, gate, room, hall, and stadium reverb
- Full complement of input controls, connections and indicators: Channel Trim controls, Peak LED's, High, Mid, and Low EQ's; Channel Submix assign and PFL buttons, EFF Send controls, Pan and Volume controls
- Effects Send and Return with level control; 2 X 5-segment LED display bargraph meters with L-R/S1-2/EFF and PFL selector and Power Amp peak indicator
- Output insert jacks on all L-R and Submix outputs for adding effects or compression before the amplifier
- Stereo headphone output with L-R/G1-2/PFL selector and separate volume adjust
- Outputs include Line Level Left and Right, Submix 1-2, Low Frequency output, and 1/4" Speaker outputs for Left and Right
- Internal shielded AC supply with 115V(60Hz)/230V(50Hz) select switch
- Dimension & Weight: 4.5" x 11.4" x 12.3" (114 x 290 x 312mm); 18.8 lbs. (8.5 Kg)

CONTENTS

FEATURES	2
WARNING	3
INSTALLATION	4
1. Inspection	4
2. Setup and Operation	4
CONTROLS AND CONNECTIONS	5
1. Channel Section	5
2. Master and Effects Section	6
3. Master Input / Output Section	7
4. Rear Panel	8
CONNECTIONS	9
BLOCK DIAGRAM	10
SPECIFICATIONS	11

Date of Purchase _____

Dealer's Name _____

City _____

State _____

Zip _____

Model # _____

Serial # _____

WARNING



An equilateral triangle enclosing a lightning flash/arrowhead symbol is intended to alert the user to the presence of uninsulated "dangerous voltage" within the product's enclosure which may be of sufficient magnitude to constitute a risk of electric shock.



An equilateral triangle enclosing an exclamation point is intended to alert the user to the presence of important operating and service instructions in the literature enclosed with this unit.

IMPORTANT SAFETY INSTRUCTIONS

When using this electronic device, basic precautions should always be taken, including the following:

1. Read all instructions before using the product.
2. Do not use this product near water (e.g., near a bathtub, washbowl, kitchen sink, in a wet basement, or near a swimming pool, etc.).
3. This product should be used only with a cart or stand that will keep it level and stable and prevent wobbling.
4. This product, in combination with headphones or speakers, may be capable of producing sound levels that could cause permanent hearing loss. Do not operate for a long period of time at a high volume level or at a level that is uncomfortable. If you experience any hearing loss or ringing in the ears, you should consult an audiologist.
5. The product should be positioned so that proper ventilation is maintained.
6. The product should be located away from heat sources such as radiators, heat vents, or other devices (including amplifiers) that produce heat.
7. The product should be connected to a power supply only of the type described in the operating instructions or as marked on the product. Replace the fuse only with one of the specified type, size, and correct rating.
8. The power supply cord should: (1) be undamaged, (2) never share an outlet or extension cord with other devices so that the outlet's or extension cord's power rating is exceeded, and (3) never be left plugged into the outlet when not being used for a long period of time.
9. Care should be taken so that objects do not fall into, and liquids are not spilled through, the enclosure's openings.
10. The product should be serviced by qualified service personnel if:
 - A. The power supply cord or the plug has been damaged.
 - B. Objects have fallen into, or liquid has been spilled onto the product.
 - C. The product has been exposed to rain.
 - D. The product does not appear to operate normally or exhibits a marked change in performance.
 - E. The product has been dropped, or the enclosure damaged.
11. Do not attempt to service the product beyond what is described in the user maintenance instructions. All other servicing should be referred to qualified service personnel.

INSTALLATION

To ensure years of enjoyment from your NADY AUDIO PMX-420, please read and understand this manual thoroughly before using the unit.

INSPECTION

Your NADY AUDIO PMX-420 powered mixer was carefully packed at the factory in packaging designed to protect the units in shipment. Before installing and using your unit, carefully examine the packaging and all contents for any signs of physical damage that may have occurred in transit.

[Please note: Nady Systems is not responsible for shipping damage. If your unit is damaged, do not return to Nady, but notify your dealer and the shipping company (if shipped to you) immediately to make a claim. Such claims must be made by the consignee in a timely manner.]

SETUP AND OPERATION

Parts of the unit can become very warm during use. This is normal during operation. Care should be taken to ensure that there is enough space around the unit for cooling. Also, do not place the PMX-420 powered mixer on high temperature devices such as power amplifiers, etc., or the unit may overheat in operation.

Although the unit's chassis is shielded against radio frequency (RF) and electromagnetic interference (EMI), extremely high fields of RF and EMI should be avoided.

Please make sure that the power unit supplied is marked for the correct voltage in your area (120VAC/60 Hz or 230VAC/50 Hz). Power requirements for electrical equipment differ from area to area. In new installations and portable sound systems, or any situation in which the AC power is in question, it is wise to confirm the voltage and use the appropriate power supply unit before connecting it to power sources.

Europe (except UK): 230V, 50Hz

UK and Australia: 240V, 50Hz

USA and Canada: 120V, 60 Hz

For other areas, please check with local authorities.

When ready to operate, plug the AC cord into the power source. Make sure that the unit is turned off before connecting to the AC power source to avoid possible loud transients which can damage your speakers or your ears. Set the **Channel (11)**, **Submix (16)**, and **Master Stereo Volume Faders (19)** to minimum to further reduce the chance of undesired noise when first powering up. Turn on your PMX-420 powered mixer by pressing on the rear panel **Power On/Off Switch (35)**.

CONTROLS AND CONNECTIONS

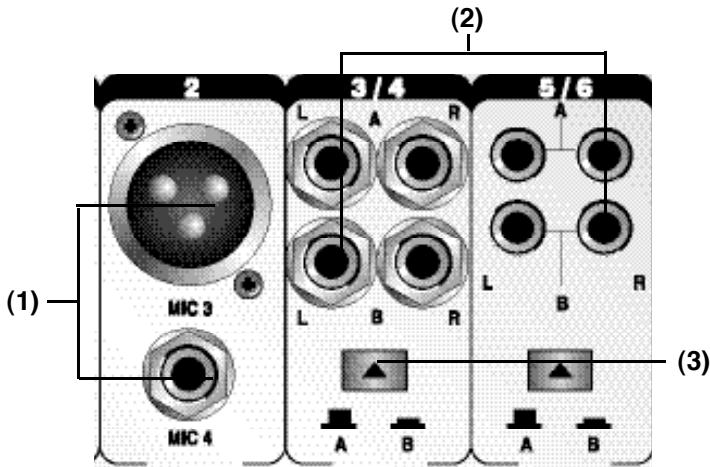

(1) CHANNEL 1 & 2 INPUTS

These electronically balanced XLR inputs are designed to accept signals from any balanced or unbalanced low impedance (Low Z) microphone. They can also be used to accept line level signals when the Gain is turned close to minimum. The XLR jack is configured: Pin 1 = ground, Pin 2 = positive (+), Pin 3 = negative (-).

The 1/4" unbalanced inputs are designed to accept unbalanced Mic or Line level signals such as those from keyboards, drum machines, or samplers. It will be necessary to adjust the input **Gain Control (4)** to achieve a nominal operating level with no clipping. The Gain Control should be set closer to minimum when using Line level input signals. All four inputs can be used simultaneously to accommodate the use of four audio sources.

(2) CHANNEL 3/4 & 5/6 STEREO INPUTS

These 1/4" and RCA unbalanced inputs are designed to accept line level signals (max 1V / 2.3dBm) such as those common to CD/tape players, keyboards, direct outputs and home stereo or DJ equipment.

Channel 3/4 1/4" inputs can also be used as standard mono line inputs by plugging into the L input only. This signal will be routed equally to the Pan control and the left and right outputs in the same way as the standard line input channels.

For each channel there are separate A and B stereo inputs. Either A or B inputs can be selected using the Input Selector Switch. This allows the user to switch to a different input source instantaneously. This is very helpful for DJ when switching to different source material or for musicians who change instruments.

(3) INPUT SELECTOR BUTTONS

These select either A or B input sources for channels 3/4 and 5/6.

(4) GAIN CONTROL

The Gain control adjusts the input sensitivity (channel gain) of the inputs. This control can be adjusted to accommodate input signals from a wide variety of sources, from the high outputs of keyboards and drum machines to the small signal outputs of microphones. The best balance of S/N and dynamic range will be achieved if you adjust the Gain control on each channel separately so that the **Channel Peak LED (5)** almost lights.

(5) CHANNEL PEAK LED

The Peak LED illuminates when a channel input is overloading. It detects the peak level after the Equalizer Controls (6) and will light just before clipping to warn that the signal is approaching overload. You do not want the Peak LED to light except very intermittently. If it lights persistently, reduce the **Gain Control (4)**. If the Gain control is set to minimum, the output level of the preceding equipment should be lowered.

(6) EQUALIZER CONTROLS

All channels are fitted with a three-band EQ - High, Mid and Low controls. All three bands have up to 15 dB of cut and boost, with a center detent for OFF. The frequency response is flat when all three EQ knobs are in the center detent position. The High and Low shelving controls have their frequencies fixed at 12 KHz and 100Hz respectively and the Mid control is fixed for peak response at 1KHz. The channel EQ is a valuable feature of the mixer as it allows the user to control the tonal characteristics of each channel separately. For example, boosting the Low can fatten the sound, add bass to vocals, or extra punch to bass, drums and synths.

The Mid control can be used to increase midrange, fatten guitars, or bring warmth to vocals. Adjusting the High control can provide a crisp sounding high end. Another very important, yet often overlooked technique is to use the EQ to subtract from the mix. Cutting the High control can reduce unwanted sibilance, hiss, cymbals, or high frequency feedback, while attenuating the Mid or Low can also eliminate feedback or clear up a muddy sounding mix. The Mid Freq control can also be used to reduce any feedback. Cutting the High and Low, then pushing up the **Channel Volume Control (11)** is equivalent to mid range boost!

[Note: Always reset a channel's input Gain Control (4) after altering the amount of equalization to avoid input overload.]

The key to successful equalization is to avoid excess. Too much equalization on the input channels will result in a mix that is smeared together with nothing specifically defined. During rehearsals, experiment with the equalizer controls on various instruments, vocals and combinations of these mixed together to become familiar with various equalizer settings.

(7) EFFECTS SEND CONTROL

This control adjusts the level of signal sent to the Effects Send

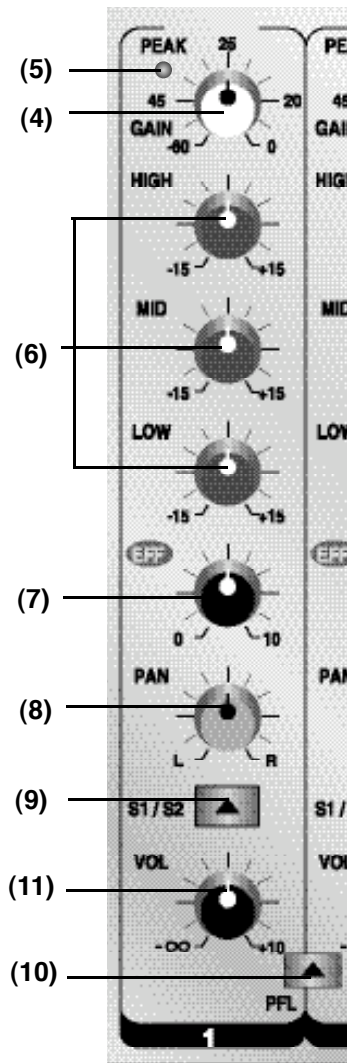

CONTROLS AND CONNECTIONS

bus or the internal DSP Echo Effects. The channel Effects Send control is mono, post-EQ, and post-Ch Volume meaning the signal level sent to the Effects Send bus will be affected by the **Channel Volume Control (11)** setting. For almost all effects send purposes, post-volume is desirable so that when a Ch Volume level is adjusted, any reverb send from that channel follows the volume. Otherwise, when the volume is turned down, the reverb from that channel would still be audible. You can also use this effect send to feed inputs of a multi-track recorder or any other unbalanced line level application.

(8) PAN

The channel Pan positions the output of the channel in the left/right stereo field of the Master mix and also pans between S1 and S2 in the Submix. Its constant-power design ensures there are no level discrepancies whether a signal is hard-panned, center-stage, or somewhere in-between.

(9) SUBMIX 1 & 2 SELECT BUTTON

When the Channel S1/S2 button is selected (button depressed), the channel signal is fed to the Submix 1 & 2 bus, controlled by the **Submix 1 & 2 Volume Faders (16)**, as well as the Main Left and Right bus. This signal is post channel Volume and the placement between Sub 1 and Sub 2 is adjusted by the Pan control. The Submix bus offers you a second stereo submix with its own stereo Sub 1 and Sub 2 master faders and Sub outputs. The Submix can be used as a mixing aid both live and in the studio; for example, to combine certain

signals to send to a monitor feed, external power amp, or to an external effects processor. It can also be used as a stereo headphone mix if faders are desired for controlling headphone volume. Using the **Submix 1 & 2 Send/Return Inserts (29)**, the Sub signal can be sent out to an external effects processor and then returned into the mixer and mixed onto the Main Left and Right bus allowing these more sensitive faders to adjust the returned signal level.

(10) CHANNEL PFL BUTTON

This button sends the pre-volume channel signal to the PFL bus for monitoring the input signal with headphones before increasing the channel volume into the mix.

(11) CHANNEL VOLUME CONTROL

This adjusts the volume level of each channel signal sent to the Effects, Submix, and Main Left & Right.

2. MASTER AND EFFECTS SECTION

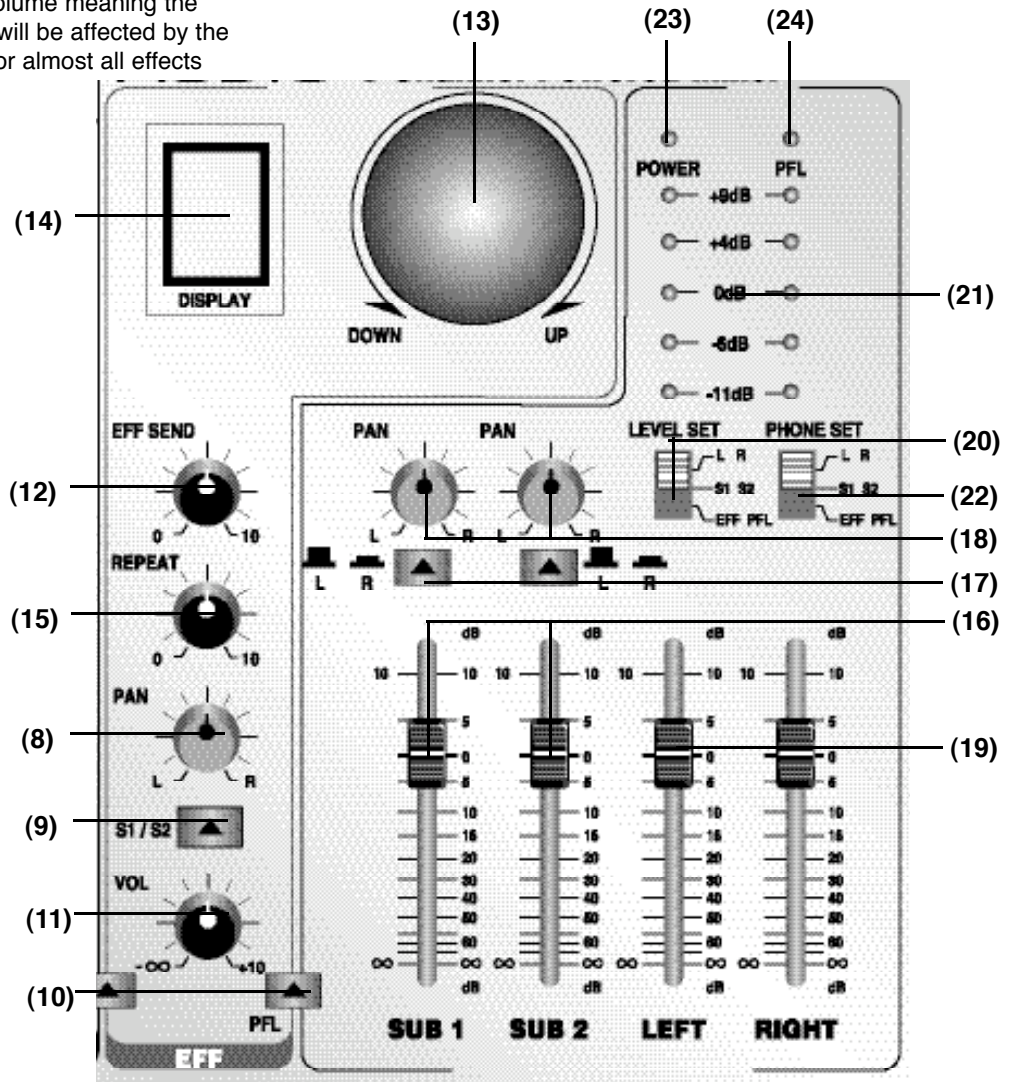

(12) EFFECTS SEND LEVEL CONTROL

This control adjusts the final mixed level of the channel Effects Send signals. This signal is then sent to either the internal Echo Effects DSP or the **Effects Send Output (27)**. Plugging into either the **Effects Send Output (27)** or **Effects Return Input (28)** jack will automatically disable the internal Echo Effects. The Effects Send signal can be output to an effects processor, multi-track recorder, or used for any other line-level auxiliary purpose, such as monitor feeds.

(13) ECHO EFFECTS DELAY TIME

This rotary wheel can be used to select one of 16 preset time intervals of the built-in Echo Effects DSP between settings 0 - F as shown on the **Echo Effects Display (14)**. Setting 0 - 2 selects the shortest echo time to emulate plate and doubling effects whereas settings 7 - F enables the longest echo time for stadium reverbs and delay sounds. Settings around 3 - 6 emulate room and hall reverbs by adjusting the **Repeat Control (15)** to approx ten o'clock.

CONTROLS AND CONNECTIONS

(14) ECHO EFFECTS DISPLAY

This numeric LED display will indicate which of the 16 echo presets has been selected (0 - F).

(15) ECHO EFFECTS REPEAT CONTROL

This control adjusts the number of repeats and feedback/depth of the echo effect. Turning the control clockwise sets the repeats to maximum for lengthy stadium echoes or plate effects. Turning the control counter-clockwise sets less repeats for doubling effects.

The **Effects Channel Pan Control (8)**, **Submix 1 & 2 Select Button (9)**, **PFL Button (10)**, and **Channel Volume Control (11)** all operate same as the other channels on the internal Echo Effects signal or the Effects Return signal.

(16) SUBMIX 1 & 2 VOLUME FADERS

These faders adjust the level of the Submix 1 & 2 signals that are sent to the **Submix 1 & 2 Outputs (30)**. These faders are post **Submix 1 & 2 Send/Return Inserts (29)** and will control any signal returning to the PMX-420 via those jacks. The Submix signal can also be selected for the **Headphone Output (26)** for easy monitoring. The Submix can be a very useful feature if used effectively. The Submix can be used as a mixing aid both live and in the studio; for example, to combine certain signals to send to a monitor feed, external power amp, or to an external effects processor. This submix can also be added to the Main/Master mix by depressing the **Submix to L-R Enable Buttons (17)**.

(17) SUBMIX TO L-R ENABLE BUTTONS

When these push-button switches are depressed, the Submix signal is added to the Main/Master bus via the Pan controls.

(18) SUBMIX TO L-R PAN CONTROLS

With the **Submix to L-R Buttons (17)** enabled, the Submix can be panned on to the Main Left & Right bus using these controls

(19) MAIN LEFT & RIGHT VOLUME FADERS

These adjust the final level of the Master Left & Right signals, that are sent to the **Main Left & Right (32)**, **Record (34)**, **Low-Pass (33)**, **Headphone (26)**, and **Speaker Stereo Outputs (36)**. These faders are post **Main Left & Right Send/Return Inserts (31)** and will affect any signal returning to the PMX-420 via those jacks.

(20) LED LEVEL SELECT SWITCH

This switch is used to select which signals will illuminate the **Dual LED Bargraph Meter (21)**. Main Stereo Left & Right signals are displayed when set to L - R. When set to S1 - S2, Submix 1 is displayed on the left and Submix 2 is displayed on the right. When set to Effects - PFL, the effects level is displayed on the left bargraph and the PFL level is displayed on the right bargraph.

(21) DUAL LED BARGRAPH METER

These 5-stage dual LED meters will display the relative output level of either the Main Left and Right, Submix 1 & 2, or Effects and PFL signals depending on the LED Level Select switch. They

can be used to maintain proper levels. When set to Main Left & Right, the top red Peak LED will light when the powered output signal is just below clipping. It is acceptable if the red LED lights occasionally. If the red LED lights more than occasionally, you should turn down the **Main Left & Right Volume Faders (19)** to avoid audible distortion and clipping, which can cause damage to your speakers and even the internal amplifier.

[Caution: Prolonged use at levels above clipping can cause damage to your speakers and even the internal amplifier. Carefully monitor the bargraph meter to avoid prolonged clipping.]

(22) HEADPHONE SELECT SWITCH

This switch is used to set which signal will be sent to the **Headphones Output (26)**. Main Stereo Left & Right signals are sent when set to L - R. When set to S1 - S2, Submix 1 is heard on the left and Submix 2 on the right. The signal of any channel with its PFL Button depressed is heard when the switch is set to PFL.

(23) POWER LED

This LED will illuminate when the unit is switched on.

(24) PFL LED

This LED will illuminate when any one of the Channel PFL Buttons (10) are switched on.

3. MASTER INPUT / OUTPUT SECTION

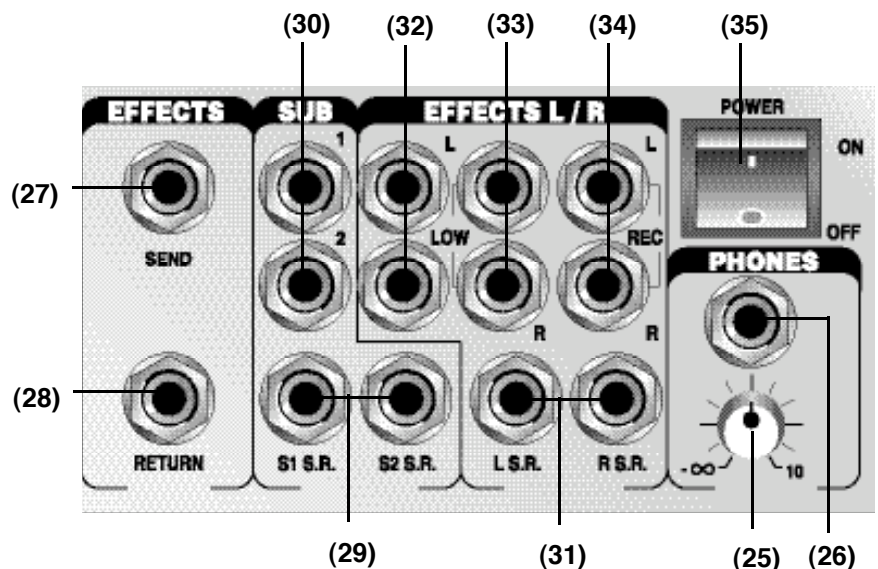

(25) HEADPHONE CONTROL

The volume control adjusts the level of the **Headphone Output (26)**. The **Headphone Select Switch (22)** determines which signal is heard.

(26) HEADPHONE OUTPUT

The Headphone 1/4" stereo output can be used to monitor the Main, Submix, or PFL signals. Capable of powering headphones with impedances of 8 ohms or greater

(27) EFFECTS SEND OUTPUT

CONTROLS AND CONNECTIONS

This mono unbalanced 1/4" jack outputs the channel signals which can be adjusted by the **Effects Send Controls (7 & 12)**.

(28) EFFECTS RETURN INPUT

This mono unbalanced 1/4" jack enables convenient inputs to the Effects Channel. If you connect a signal to the return jacks, the signal will be routed to the effects **Channel Volume Control (11)**.

Plugging into either the **Effects Send Output (27)** or **Effects Return Input (28)** jacks will automatically disable the internal Echo Effects.

(29) SUBMIX 1 & 2 SEND/RETURN INSERTS

These 1/4" TRS insert jacks can be used to send out the Submix signals to an external device and return the signals back via the same jack. They are pre-Sub 1 & 2 fader and allow for routing the signal through external devices such as equalizers, compressors, or effects units. Insert cables must be used for these connections. The wiring for the insert jacks is Tip = Send, Ring = Return.

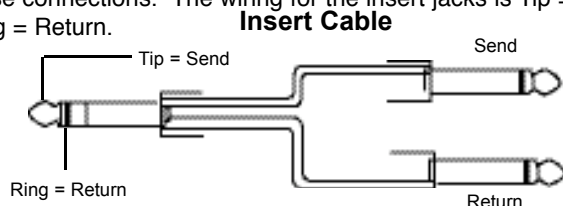

(30) SUBMIX 1 & 2 OUTPUTS

These 1/4" jacks output the Submix 1 & 2 unbalanced line level signals.

(31) MAIN LEFT & RIGHT SEND/RETURN INSERTS

These 1/4" TRS insert jacks can be used to send out the Main Left & Right signals to an external device and return the signals via the same jack. They are pre-Main Left & Right Volume fader and allow for routing the signal through external devices such as equalizers, compressors, or effects units. Insert cables must be used for these connections. The wiring for the insert jacks is Tip = Send, Ring = Return.

(32) MAIN LEFT & RIGHT OUTPUTS

These 1/4" jacks output unbalanced line level signals from the Main Left and Right volume faders.

(33) LOW-PASS LEFT & RIGHT OUTPUTS

These 1/4" jacks output unbalanced line level signals that have been filtered through a Low Pass filter. This output is perfect for feeding directly to an amplifier that powers a subwoofer speaker or to a powered subwoofer with no crossover necessary. The frequency response is 30Hz - 150Hz (-6dB) with a -12dB roll-off point at 250Hz. These signals are post Main Left & Right faders.

(34) RECORD LEFT & RIGHT OUTPUTS

These 1/4" jacks output unbalanced line level signals from the Left and Right bus. These signals are pre Main Left & Right faders.

4. REAR PANEL

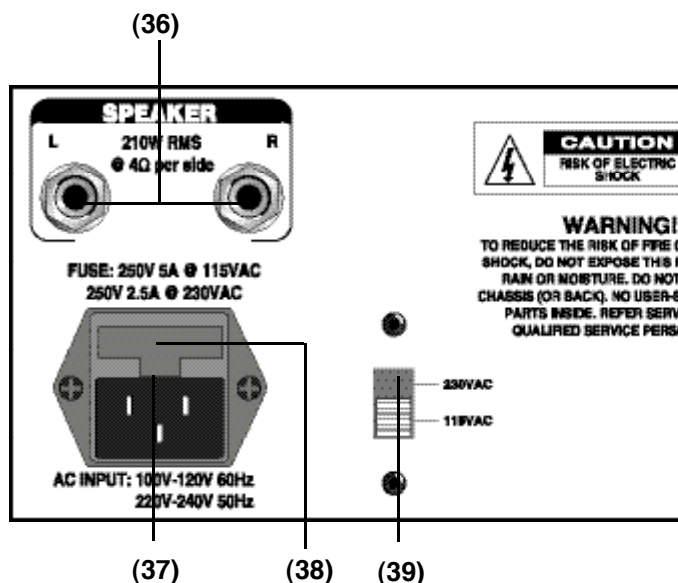

(35) POWER ON/OFF SWITCH

Use this rocker switch to turn the unit on and off.

(36) STEREO SPEAKER OUTPUTS

These Left & Right 1/4" speaker outputs can each deliver up to 210W RMS to 4 ohms loads or 150W RMS to 8 ohms loads with both channels driven simultaneously.

[Caution: Make sure that the speaker, connectors and wiring can handle the rated output power to avoid damage. Note that prolonged use at levels above clipping can drive the amplifier into thermal runaway and damage the internal amplifier and speaker, so care must be taken to not overload the amplifier. Never use less than 4 ohms total impedance for either channel as this can also cause the amplifier to overheat and create thermal runaway.]

(37) POWER CONNECTOR

The IEC jack is used to connect the power cord to the AC Power Source.

[Caution: Never remove the center grounding pin as this can cause a serious safety hazard and will immediately void your warranty.]

(38) FUSE COMPARTMENT

Replace with only the same type fuse. If the fuse blows continuously, have the unit serviced by qualified personnel. The PMX-420 powered mixer uses 20mm glass tube Fast Blow fuses: 5A 250V for 115VAC, 2.5A 250V for 230VAC.

(39) AC VOLTAGE SELECTOR SWITCH

Before plugging in the power cord, check to see that the unit is set for the proper voltage for your area: ~115V (60Hz) or ~230V (50Hz).

CONNECTIONS

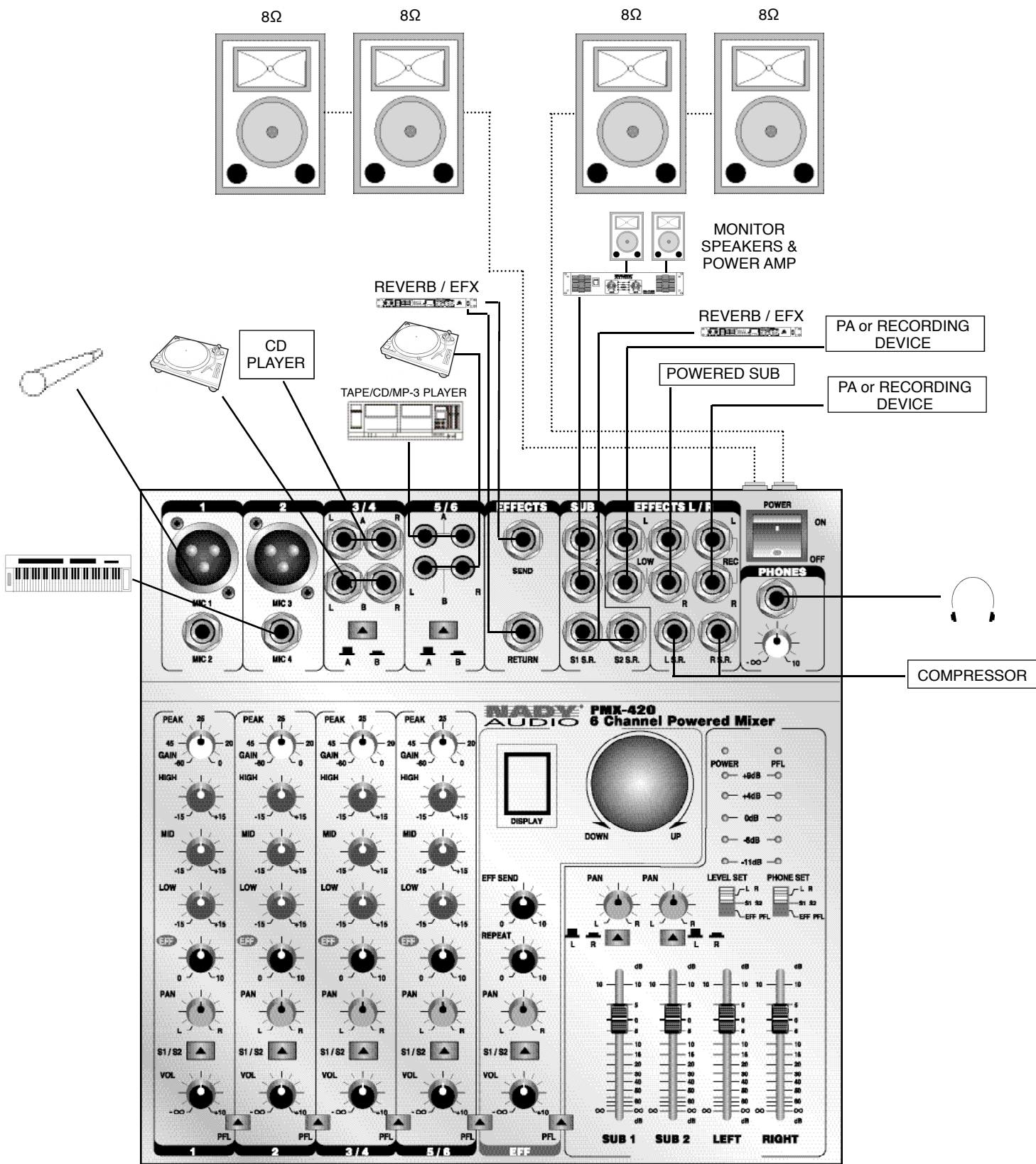

BLOCK DIAGRAM

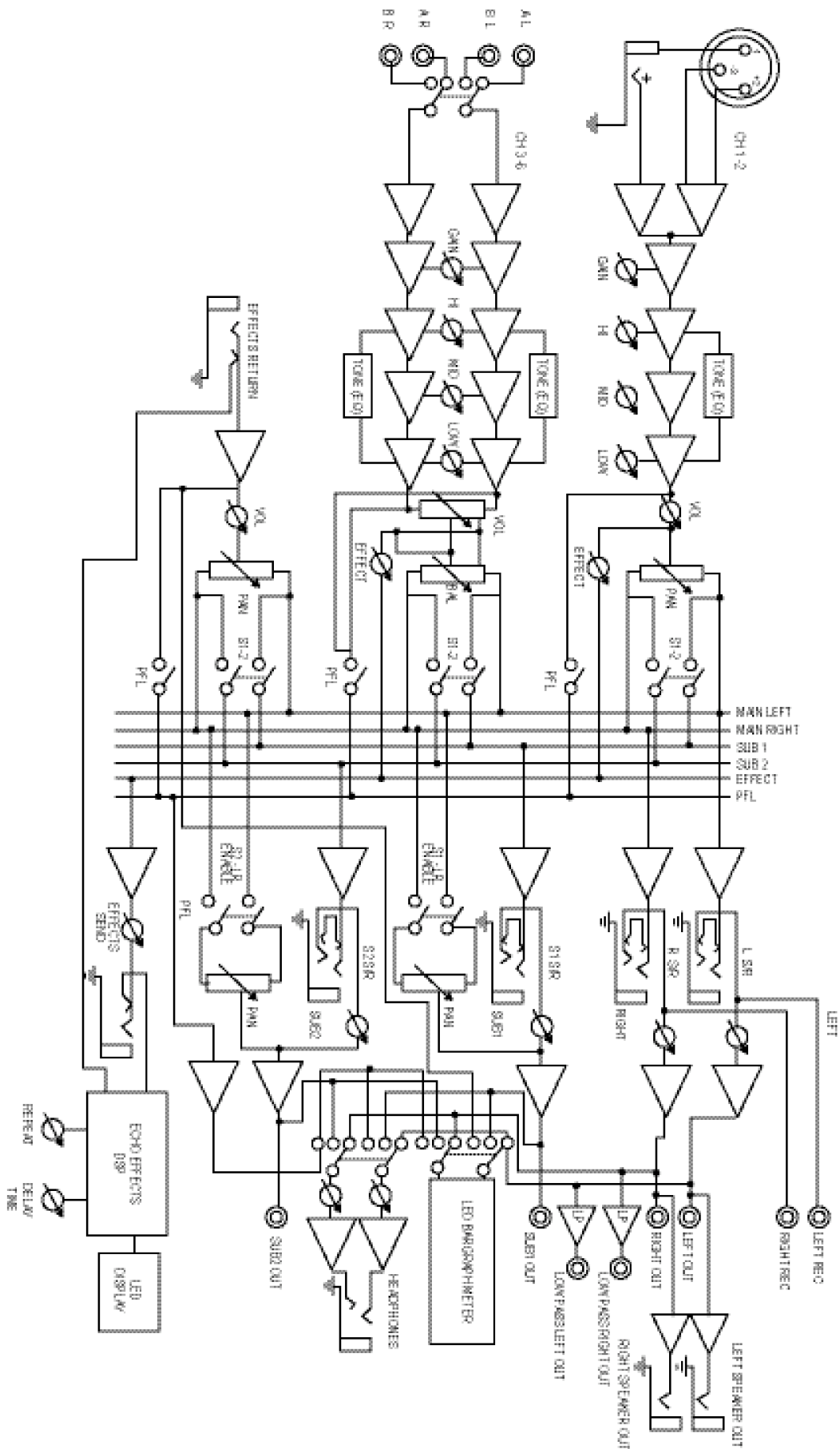

SPECIFICATIONS

1. INPUTS

Input	Connector	Impedance	Sensitivity	Max Level
CHANNEL 1-2	XLR BALANCED	10K Ω	-60 dBm / 0.7mV	0 dBm / 0.775V
CHANNEL 1-2	1/4" UNBALANCED	5K Ω	-54 dBm / 1.4mV	+4 dBm / 1.2V
CHANNEL 3-4 Mono	1/4" UNBALANCED	4K Ω	-32 dBm / 20mV	+2 dBm / 1V
CHANNEL 3-6 STEREO	1/4" & RCA UNBALANCED	8K Ω	-32 dBm / 20mV	+2 dBm / 1V
EFFECTS RETURN	1/4" UNBALANCED	22K Ω	-27 dBm / 33mV	+2 dBm / 1V
SUB INSERT RETURNS	1/4" UNBALANCED RING	7K Ω	-10 dBm / 240mV	+5 dBm / 1.4V
MAIN INSERT RETURNS	1/4" UNBALANCED RING	5K Ω	0 dBm / 0.775mV	+5 dBm / 1.4V

Sensitivity measured for max power with all volumes at max, EQ's at mid
Maximum Input Level measured with Gain set to min

2. MIXER SECTION

Channel High EQ +/-15dB	12KHz, Rotary control
Channel Mid EQ +/-15dB	1KHz, Rotary control
Channel Low EQ +/-15dB	100Hz, Rotary control
Channel Gain, Effects Send, Pan, Volume	Rotary controls
PFL, S1-2 Select	Push-button switches
Echo Effect Time Delay (0 - F)	6 presets 20-350mS
Master and Submix dual faders	$-\infty$ to +10dB, 50mm sliders

3. MASTER OUTPUT SECTION

Channel Input to Main Output	
Frequency Response	20Hz~25KHz (+/- 3dB)
THD + Noise	0.08%
S/N Ratio	-80dB (gain controls @ mid, faders at 0dB)
Noise Floor	550uV (gain controls @ mid, faders at 0dB)
Total Gain	60dB

EFFECTS SEND	1/4" UNBALANCED	1.5K Ω	+16dBm / 5V
SUBMIX INSERT SEND	1/4" UNBALANCED TIP	150 Ω	+10dBm / 2.4V
SUBMIX 1-2	1/4" UNBALANCED	150 Ω	+12Bm / 3V
MAIN L-R INSERT SEND	1/4" UNBALANCED TIP	150 Ω	+12Bm / 3V
MAIN L-R	1/4" UNBALANCED	200 Ω	+16dBm / 5V
RECORD L-R	1/4" UNBALANCED	150 Ω	+12Bm / 3V
LOW PASS L-R30Hz-150Hz	1/4" UNBALANCED	150 Ω	+12Bm / 3V
HEADPHONE (w/32 Ω load)	1/4" TRS STEREO	32 Ω	2 x 20mW

4. POWER OUTPUT SECTION

Power Output	
8 Ω Both Channels Driven (1% THD)	150W RMS per side
4 Ω Both Channels Driven (1% THD)	210W RMS per side

Channel Input to Speaker Output

Frequency Response	20Hz~22KHz (+/- 3dB)
THD	0.07%
S/N Ratio	-74dB (gain controls @ mid, faders at 0)
Noise Floor	6.2mV (gain controls @ mid, faders at 0)
Total Gain	94dB

Amplifier Protection Fan cooling, short circuit protection, DC protection circuits, clip LED indicators, Power ON/OFF relays

5. GENERAL

Power Requirements	Voltage selectable, 115VAC/60Hz or 230VAC /50Hz
Fuse Requirements	5x20mm glass tube F.B. 5A 250V @ 115VAC 2.5A 250V @ 230VAC
Weight	18.8 lbs. (8.5 Kg)
Dimensions (HWD)	4.5" x 11.4" x 12.3" (114 x 290 x 312mm)

The specifications above are correct at the time of printing of this manual. For improvement purposes, all specifications for this unit, including design and appearance, are subject to change without prior notice.

SERVICE FOR YOUR NADY AUDIO PRODUCT

(U.S.) Should your NADY AUDIO product require service, please contact the Nady Service Department via telephone at (510) 652-2411, or e-mail at service@nady.com.

(International) For service, please contact the NADY AUDIO distributor in your country through the dealer from whom you purchased this product.

DO NOT ATTEMPT TO SERVICE THIS UNIT
YOURSELF AS IT CAN BE DANGEROUS
AND WILL ALSO VOID THE WARRANTY.



NADY SYSTEMS, INC. • 6701 SHELLMOUND STREET, EMERYVILLE, CA 94608
Tel: 510.652.2411 • Fax: 510.652.5075 • nady.com
