

Reebok® RL 900

Model No. RBE0995.1

Serial No. _____

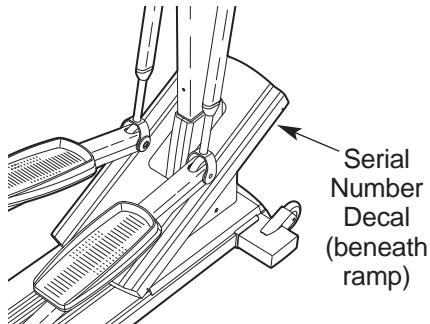

USER'S MANUAL

QUESTIONS?

As a manufacturer, we are committed to providing complete customer satisfaction. If you have questions, or if parts are damaged or missing, PLEASE CONTACT OUR CUSTOMER SERVICE DEPARTMENT DIRECTLY.

CALL TOLL-FREE:

1-877-994-4999

Mon.–Fri., 6 a.m.–6 p.m. MST

ON THE WEB:

www.reebokservice.com

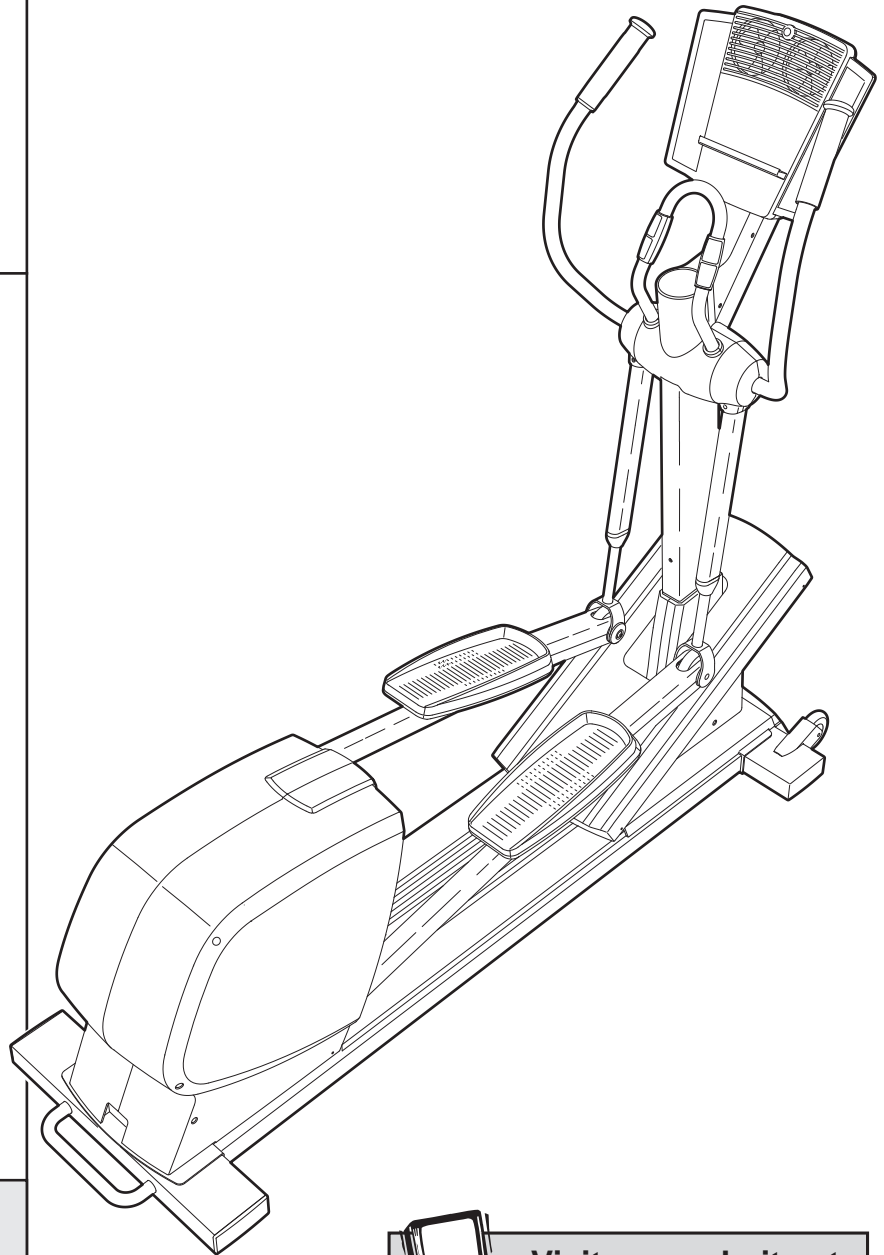

CAUTION

Read all precautions and instructions in this manual before using this equipment. Keep this manual for future reference.



Visit our website at

www.reebokhomefitness.com

*new products, prizes,
fitness tips, and much more!*

TABLE OF CONTENTS

IMPORTANT PRECAUTIONS	2
BEFORE YOU BEGIN	3
ASSEMBLY	4
ELLIPTICAL EXERCISER OPERATION	9
MAINTENANCE AND TROUBLESHOOTING	22
EXERCISE GUIDELINES	23
PART LIST	24
EXPLODED DRAWING	26
ORDERING REPLACEMENT PARTS	Back Cover
LIMITED WARRANTY	Back Cover

IMPORTANT PRECAUTIONS

⚠ WARNING: To reduce the risk of serious injury, read the following important precautions before using the elliptical exerciser.

1. Read all instructions in this manual and all warnings on the elliptical exerciser before using the elliptical exerciser.
2. Use the elliptical exerciser only as described in this manual.
3. It is the responsibility of the owner to ensure that all users of the elliptical exerciser are adequately informed of all precautions.
4. The elliptical exerciser is intended for home use. Do not use the elliptical exerciser in a commercial, rental, or institutional setting.
5. Keep the elliptical exerciser indoors, away from moisture and dust. Place the elliptical exerciser on a level surface, with a mat beneath it to protect the floor or carpet. Make sure that there is enough clearance around the elliptical exerciser to mount, dismount, and use the elliptical exerciser.
5. Inspect and properly tighten all parts regularly. Replace any worn parts immediately.
6. Keep children under age 12 and pets away from the elliptical exerciser at all times.
7. The elliptical exerciser should not be used by persons weighing more than 350 pounds.
8. Always hold the handlebars when mounting, dismounting, or using the elliptical exerciser.
9. Wear appropriate exercise clothes when using the elliptical exerciser. Always wear athletic shoes for foot protection.
10. Keep your back straight when using the elliptical exerciser; do not arch your back.
11. If you feel pain or dizziness while exercising, stop immediately and begin cooling down.
12. The pulse sensor is not a medical device. Various factors, including the user's movement, may affect the accuracy of heart rate readings. The pulse sensor is intended only as an exercise aid in determining heart rate trends in general.
13. When you stop exercising, allow the pedals to slowly come to a complete stop. The elliptical exerciser does not have a free wheel; the pedals will continue to move until the flywheel stops.
14. Always unplug the power cord immediately after use and before cleaning the elliptical exerciser.

⚠ WARNING: Before beginning this or any exercise program, consult your physician. This is especially important for persons over the age of 35 or persons with pre-existing health problems. Read all instructions before using. ICON assumes no responsibility for personal injury or property damage sustained by or through the use of this product.

BEFORE YOU BEGIN

Congratulations for selecting the new REEBOK® RL 900 elliptical exerciser. The RL 900 elliptical exerciser is an incredibly smooth exerciser that moves your feet in a natural elliptical path, minimizing the impact on your knees and ankles. And the unique RL 900 elliptical exerciser features adjustable resistance and incline to help you get the most from your exercise.

For your benefit, read this manual carefully before you use the elliptical exerciser. see the front cover of this manual. To help us assist you, please note the

product model number and serial number before calling. The model number is RBE0995.1. The serial number can be found on a decal attached to the exercise cycle (see the front cover of this manual).



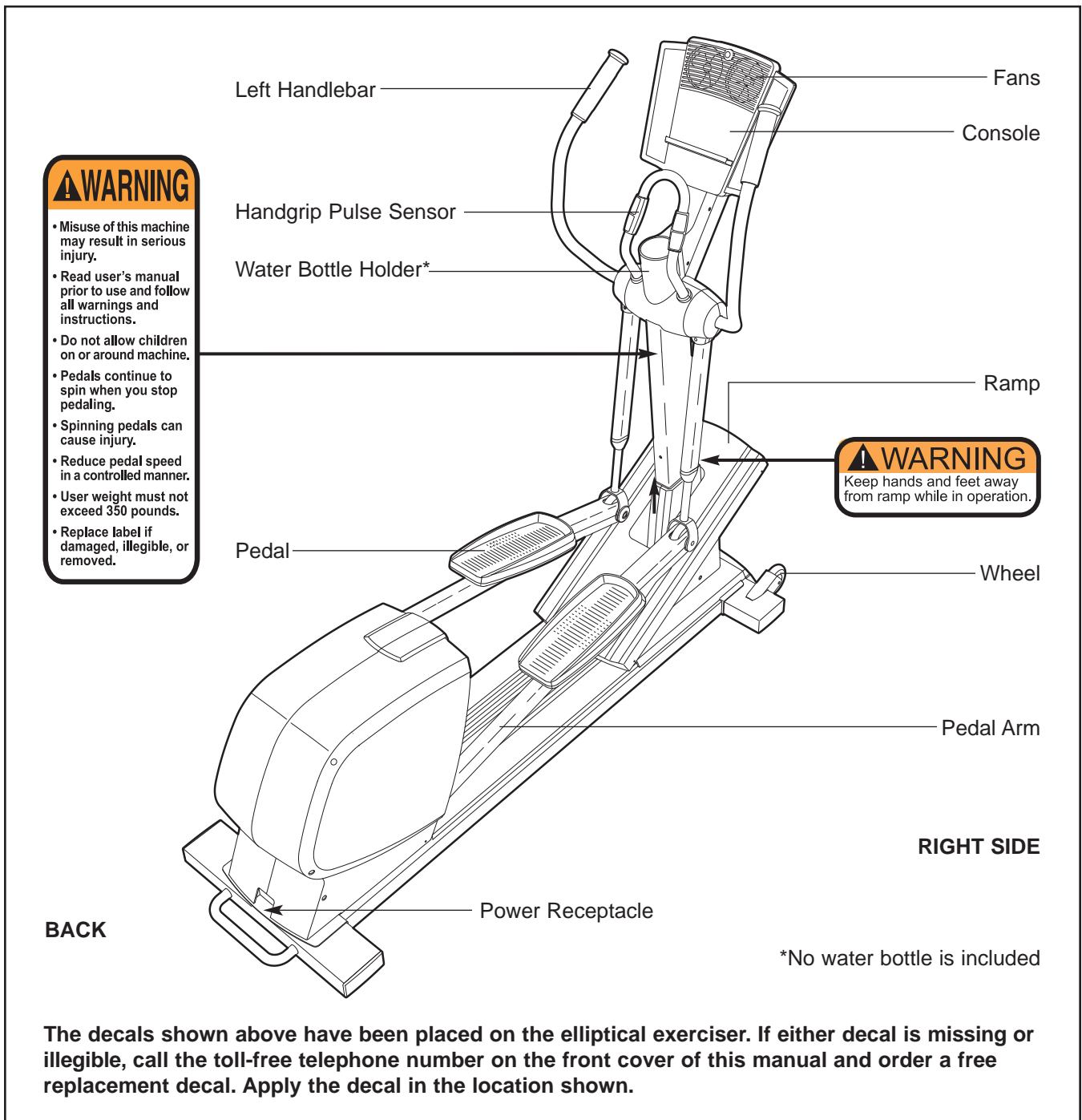

To avoid a registration fee for any service needed under warranty, you must register the elliptical exerciser at www.reebokservice.com/registration.

Before reading further, please familiarize yourself with the parts that are labeled in the drawing below.



ASSEMBLY

To hire an authorized service technician to assemble the elliptical exerciser, call toll-free 1-800-445-2480.

Assembly requires two persons. Place all parts of the elliptical exerciser in a cleared area and remove the packing materials. Do not dispose of the packing materials until assembly is completed. **In addition to the two included hex keys, assembly requires a phillips screwdriver** , **two adjustable wrenches** , **a rubber mallet** , and **pliers** .

Use the drawings below to identify the small parts used for assembly. The number in parentheses below each drawing is the key number of the part, from the PART LIST on pages 24 and 25. The number following the key number is the quantity needed for assembly. **Note: Some small parts may have been preassembled. If a part is not in the parts bag, check to see if it has been preassembled.**

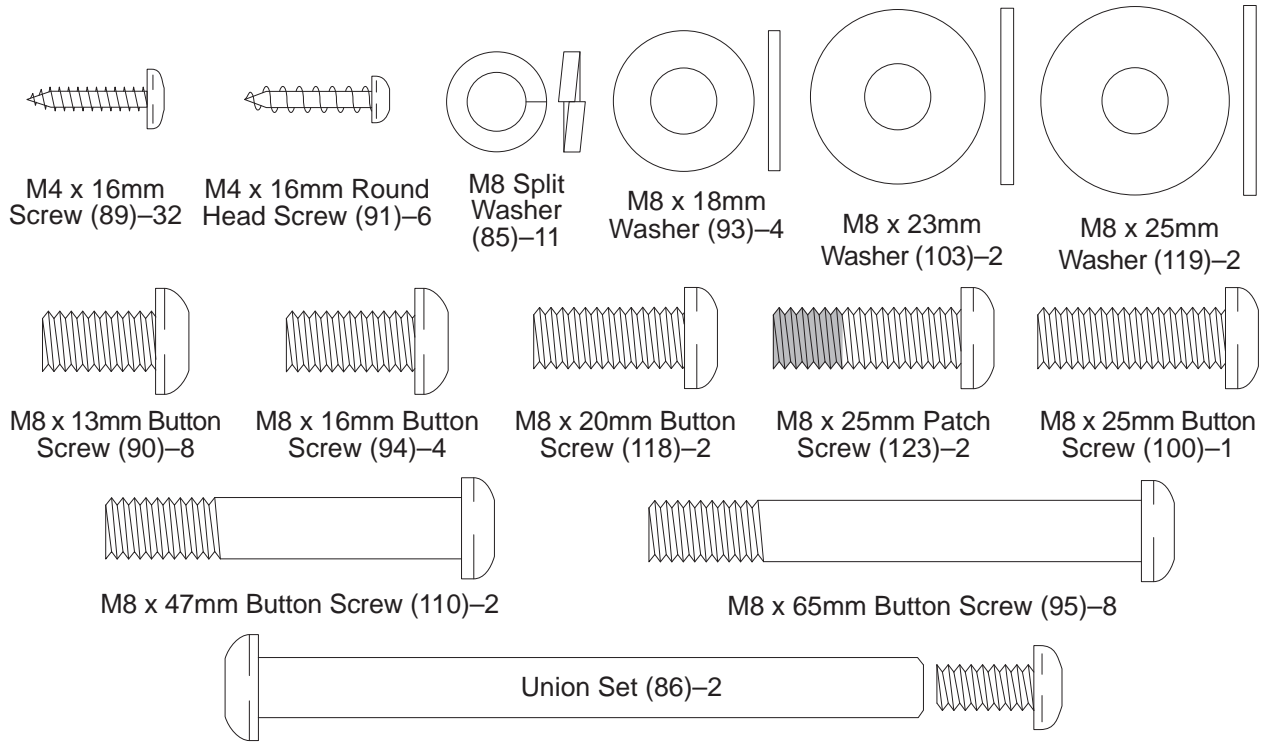

1. Orient the Front Stabilizer (3) as shown. Attach the Front Stabilizer to the Frame (1) with four M8 x 65mm Button Screws (95) and four M8 Split Washers (85).

Next, attach the Front Shield (38) to the Front Stabilizer (3) with two M4 x 16mm Round Head Screws (91).

Then, tighten the two Frame Cushions (106) into the underside of the Frame (1).

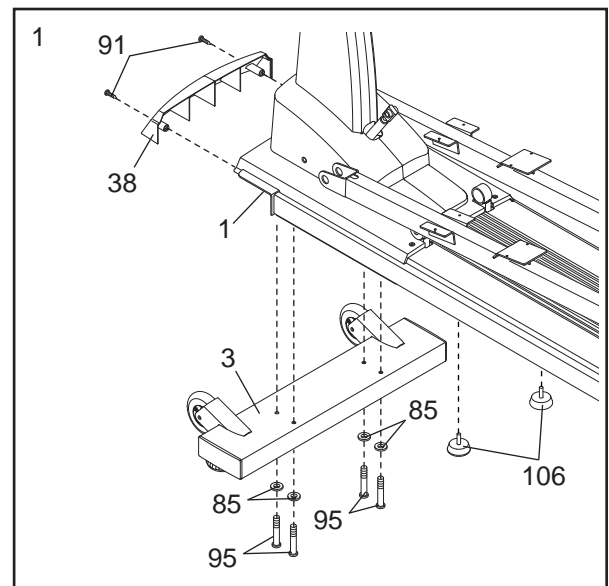

2. Orient the Rear Stabilizer (2) as shown. Attach the Rear Stabilizer to the Frame (1) with four M8 x 65mm Button Screws (95) and four M8 Split Washers (85).

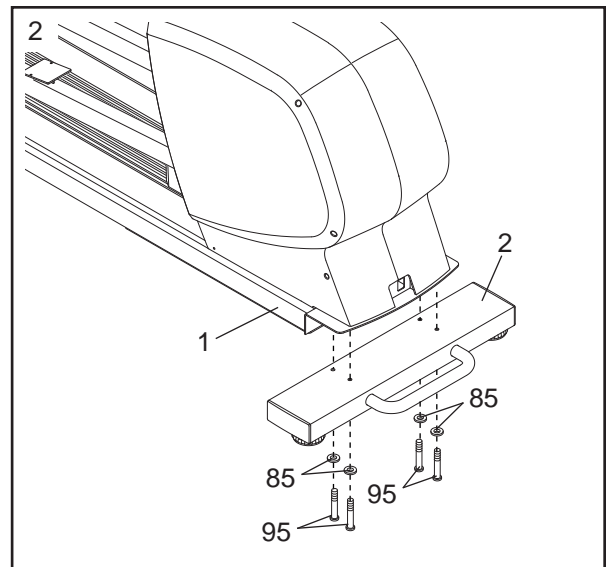

3. Slide an M8 x 25mm Washer (119) onto an M8 x 20mm Button Screw (118). Tighten the Button Screw into one end of the Incline Axle (68). Apply a small amount of the included grease to the Incline Axle.

Orient the Ramp (5) so the opening is in the position shown. Fit the welded tube on the underside of the Ramp between the two rings on the top of the Frame (1). Insert the Incline Axle (68) through the rings and the welded tube.

Slide an M8 x 25mm Washer (119) onto an M8 x 20mm Button Screw (118). Tighten the Button Screw into the open end of the Incline Axle (68).

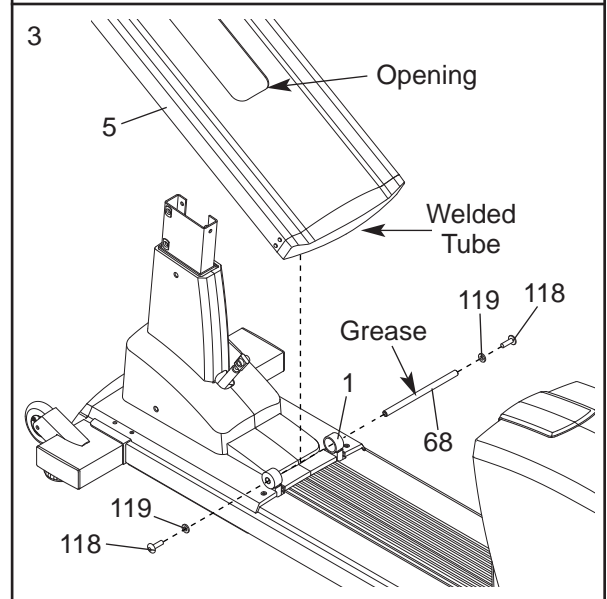

4. Using your fingers, turn the shaft on top of the Motor (46) counterclockwise until it stops turning. Next, fit the opening of the Ramp (5) over the front of the Frame (1) as shown. Position the U-bracket on the underside of the Ramp over the end of the shaft as shown.

Insert the Clevis Pin (112) through one side of the U-bracket on the Ramp (5), an 8mm Plastic Spacer (111), the shaft on the Motor (46), another 8mm Plastic Spacer, and the other side of the U-bracket. Then, insert the straight end of a Hairpin Cotter Pin (65) through the hole in the Clevis Pin.

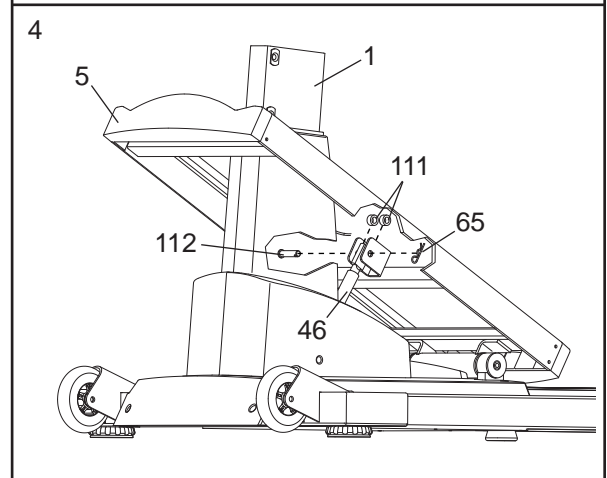

5. Attach a Pedal Assembly (39) to the Left Pedal Arm (9) with five M4 x 16mm Screws (89).

Attach the other Pedal Assembly (not shown) to the Right Pedal Arm (not shown) in the same way.

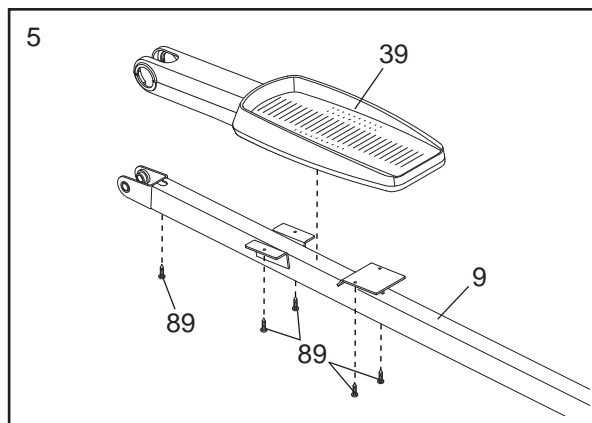

6. Remove the two Pivot Shafts (10) from the two Pivot Arms (not shown). Next, identify a Union Set (86), and remove the screw from the barrel. Apply a small amount of grease to the outside of the barrel.

Slide an M8 x 18mm Washer (93), a Wheel Cap (53), and a 30mm Spacer (87) onto the barrel of the Union Set (86). While another person aligns the indicated holes in the Left Pedal Assembly (39), a Pedal Arm Wheel (52), and a Pivot Shaft (10), insert the barrel through all of the holes. Then, slide another 30mm Spacer (87) onto the barrel.

Next, slide an M8 x 18mm Washer (93) and a Wheel Cap (53) onto the screw of the Union Set (86), and tighten the screw into the barrel.

Attach the other Pivot Shaft (not shown) and the other Pedal Arm Wheel (not shown) to the Right Pedal Assembly (not shown) in the same way.

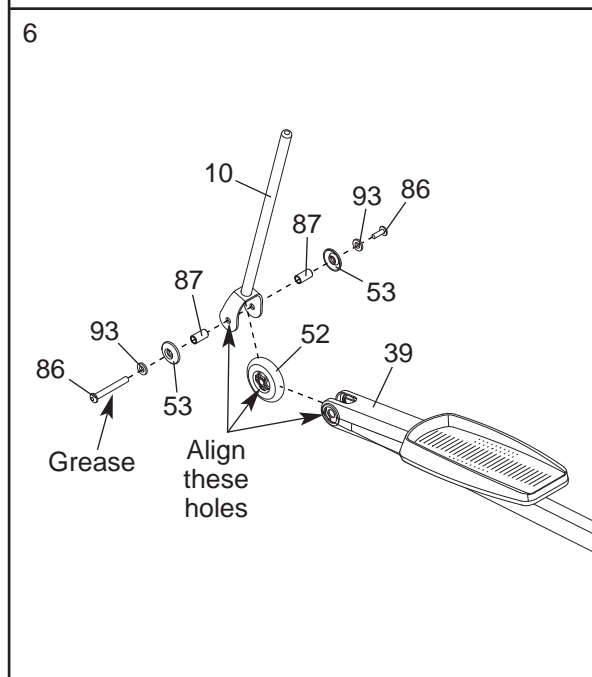

7. While another person holds the Upright (4) near the Frame (1), connect the Upper Wire Harness (58) to the Extension Wire Harness (59). Slide the Upright onto the top of the Frame, **being careful not to pinch the Wire Harnesses.**

Attach the Upright (4) to the Frame (1) with two M8 x 47mm Button Screws (110), an M8 x 25mm Button Screw (100), and three M8 Split Washers (85).

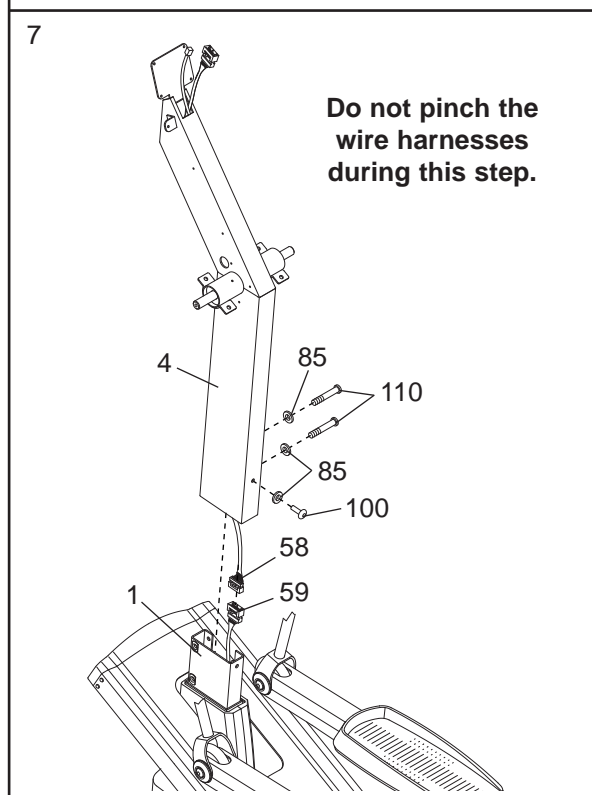

- While another person holds the Pulse Sensor Bar (26) near the Upright (4), connect the upper pulse wires to the lower pulse wires. Insert the excess wire into the Upright.

Orient the Pulse Sensor Bar (26) as shown. Attach the Pulse Sensor Bar to the Upright (4) with four M8 x 16mm Button Screws (94), **being careful not to pinch the wires**.

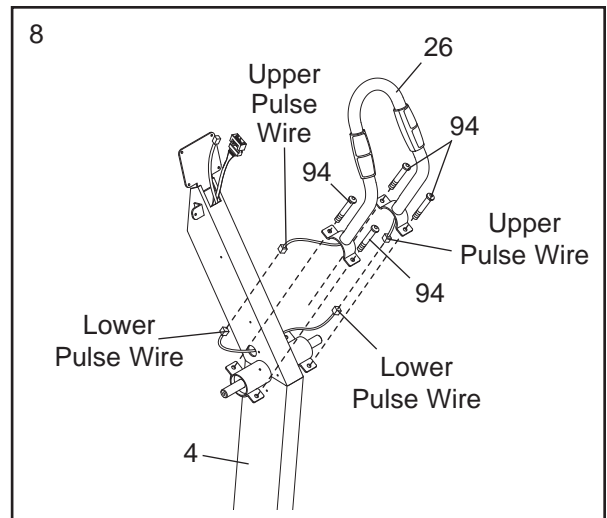

- Identify the Front Center Pivot Cover (27). Attach the Front Center Pivot Cover to the Frame (1) with four M4 x 16mm Screws (89).

Next, identify the Rear Center Pivot Cover (28). Attach the Rear Center Pivot Cover to the Frame (1) with four M4 x 16mm Screws (89).

Attach the Water Bottle Holder (23) to the Upright (4) with four M4 x 16mm Screws (89).

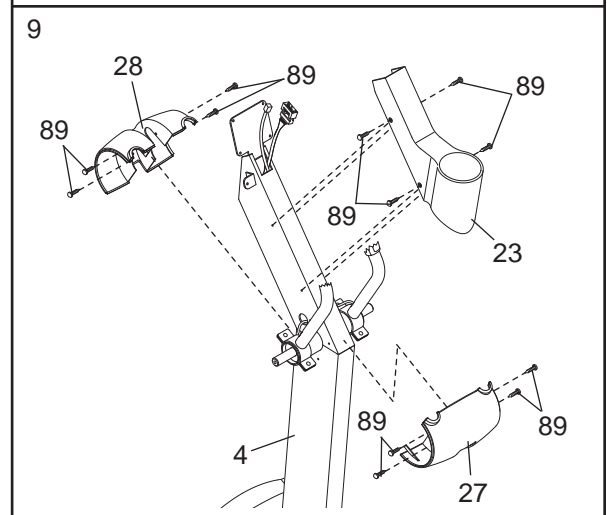

- Apply a small amount of the included Teflon® lubricant to a paper towel, and rub a thin film of the lubricant onto both of the Pivot Shafts (10). Next, apply a small amount of grease to the axle in the Upright (4).

Then, slide a 5mm Spacer (35) onto each end of the axle in the Upright (4).

Next, slide the two Pivot Arms (20) onto the Pivot Shafts (10), and turn the Pivot Arms so the flanges are facing away from the elliptical exerciser. Then, slide the Pivot Arms onto the ends of the axle in the Upright (4); use a rubber mallet, if necessary.

Slide an M8 x 23mm Washer (103) onto an M8 x 25mm Patch Screw (123). Attach the left Pivot Arm (20) to the left end of the axle with the Patch Screw.

Attach the right Pivot Arm (20) to the right end of the axle in the same way.

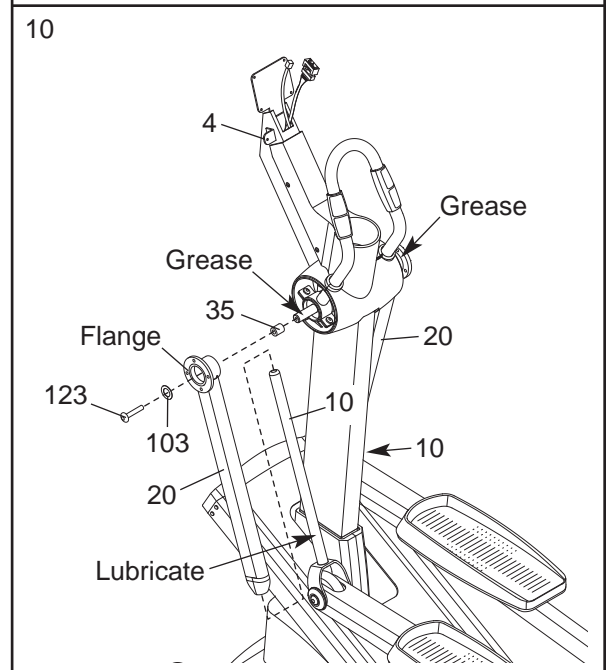

11. Identify the Left Handlebar (7). Attach the Left Handlebar to the left Pivot Arm (20) with four M8 x 13mm Button Screws (90) as shown.

Attach the Right Handlebar (6) to the right Pivot Arm (20) in the same way.

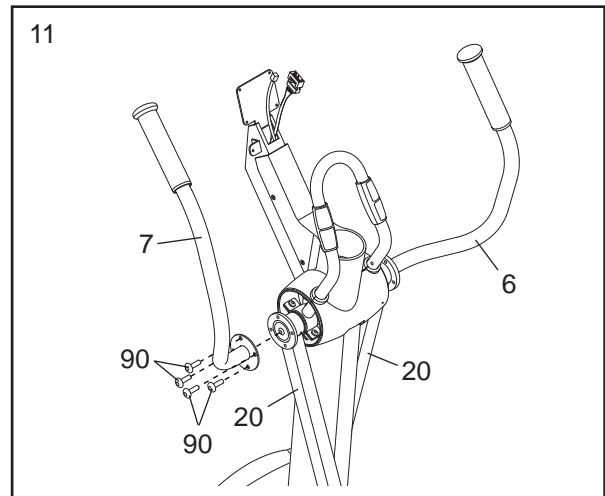

12. Position the Front Left Pivot Cover (21) and the Rear Left Pivot Cover (31) over the left Pivot Arm (20) as shown. Attach the Left Pivot Covers with an M4 x 16mm Round Head Screw (91) and two M4 x 16mm Screws (89).

Attach the Front Right Pivot Cover (29) and the Rear Right Pivot Cover (not shown) over the right Pivot Arm (not shown) in the same way.

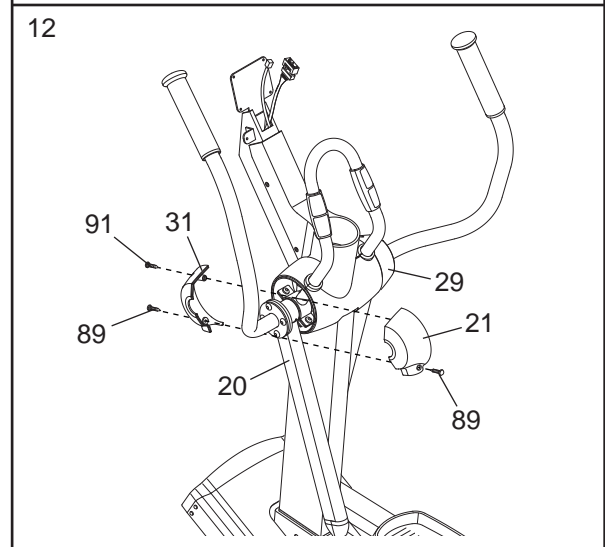

13. While another person holds the Console (17) near the Upright (4), attach the Upper Wire Harness (58) and the Pulse Sensor Wire (25) to the corresponding console wire harnesses. Then, attach the Console to the Upright with six M4 x 16mm Screws (89), **being careful not to pinch the wires.**

Attach the Upright Cover (22) to the Upright (4) with two M4 x 16mm Round Head Screws (91).

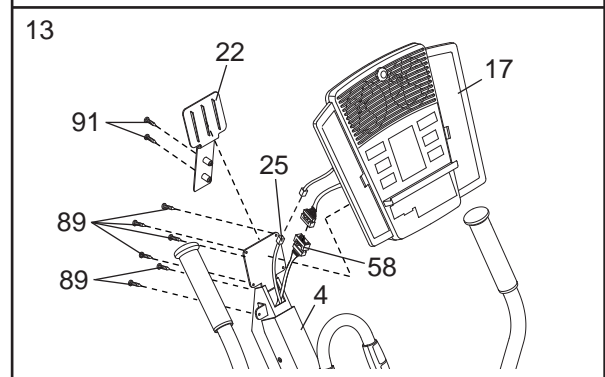

14. Plug the Power Cord (56) into the Power Receptacle (70) at the rear of the elliptical exerciser.

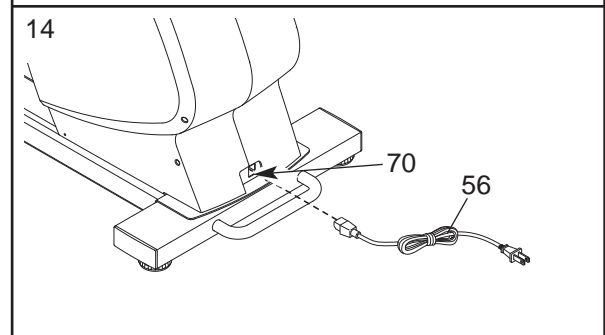

15. **Make sure that all parts of the elliptical exerciser are properly tightened.** Cover the floor beneath the elliptical exerciser to protect the floor from damage. Note: Some extra hardware may be left over.

ELLIPTICAL EXERCISER OPERATION

HOW TO PLUG IN THE POWER CORD

This product must be grounded.

If it should malfunction or break down, grounding provides a path of least resistance for electric

current to reduce the risk of electric shock. This product is equipped with a cord having an equipment-grounding conductor and a grounding plug. **Plug the power cord into an appropriate outlet that is properly installed and grounded in accordance with all local codes and ordinances. This product is for use on a nominal 120-volt circuit. Important: The elliptical exerciser is not compatible with GFCI-equipped outlets.**

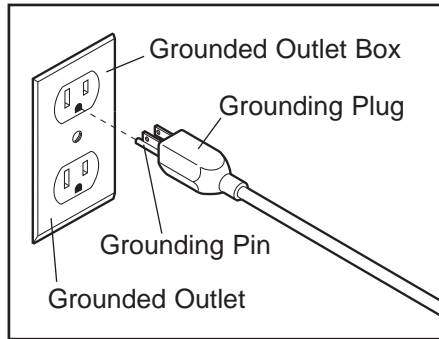

⚠ DANGER: Improper connection of the equipment-grounding conductor can result in an increased risk of electric shock. Check with a qualified electrician or serviceman if you are in doubt as to whether the product is properly grounded. Do not modify the plug provided with the product—if it will not fit the outlet, have a proper outlet installed by a qualified electrician.

A temporary adapter may be used to connect the power cord to a 2-pole receptacle as shown at the right if a properly grounded outlet is not

available. The temporary adapter should be used only until a properly grounded outlet can be installed by a qualified electrician.

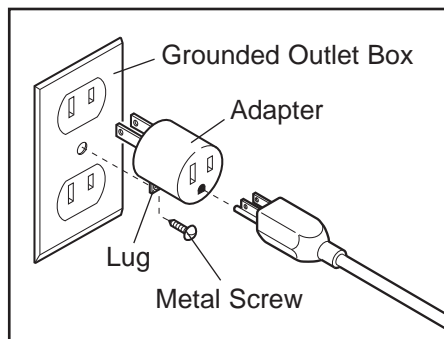

The green-colored rigid ear, lug, or the like extending from the adapter must be connected to a permanent ground such as a properly grounded outlet box cover. Whenever the adapter is used, it must be held in place by a metal screw. **Some 2-pole receptacle outlet box covers are not grounded. Contact a qualified electrician to determine if the outlet box cover is grounded before using an adapter.**

Note: When the power cord is plugged in, the elliptical exerciser's incline system may automatically calibrate itself. During the calibration process, two dashes (– –) will appear in the Ramp display while the ramp rises to the highest position and then moves down to the lowest position. The calibration process may last for one to two minutes. If the incline system does not calibrate itself, see **HOW TO CALIBRATE THE INCLINE SYSTEM** on page 22.

EXERCISING ON THE ELLIPTICAL EXERCISER

To mount the elliptical exerciser, hold the handlebars and step onto the pedal that is in the lowest position. Next, step onto the other pedal. Push the pedals until they begin to move with a continuous motion.

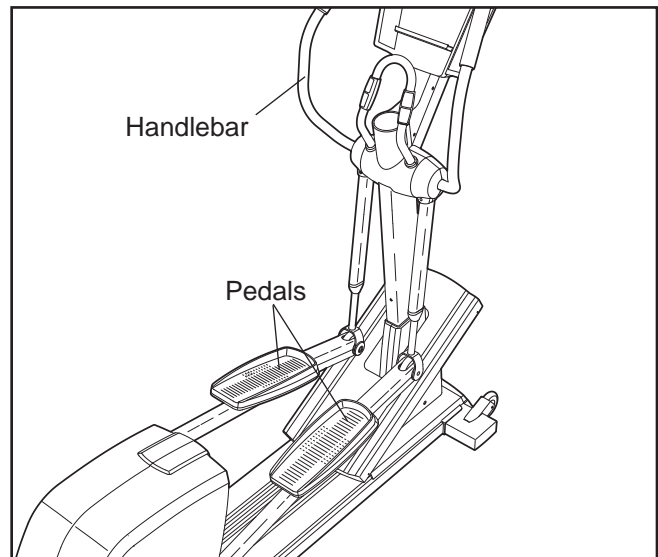

To dismount the elliptical exerciser, wait until the pedals come to a complete stop. **The elliptical exerciser does not have a free wheel; the pedals will continue to move until the flywheel stops.** When the pedals are stationary, step off the highest pedal first. Then, step off the lowest pedal.

CONSOLE DIAGRAM

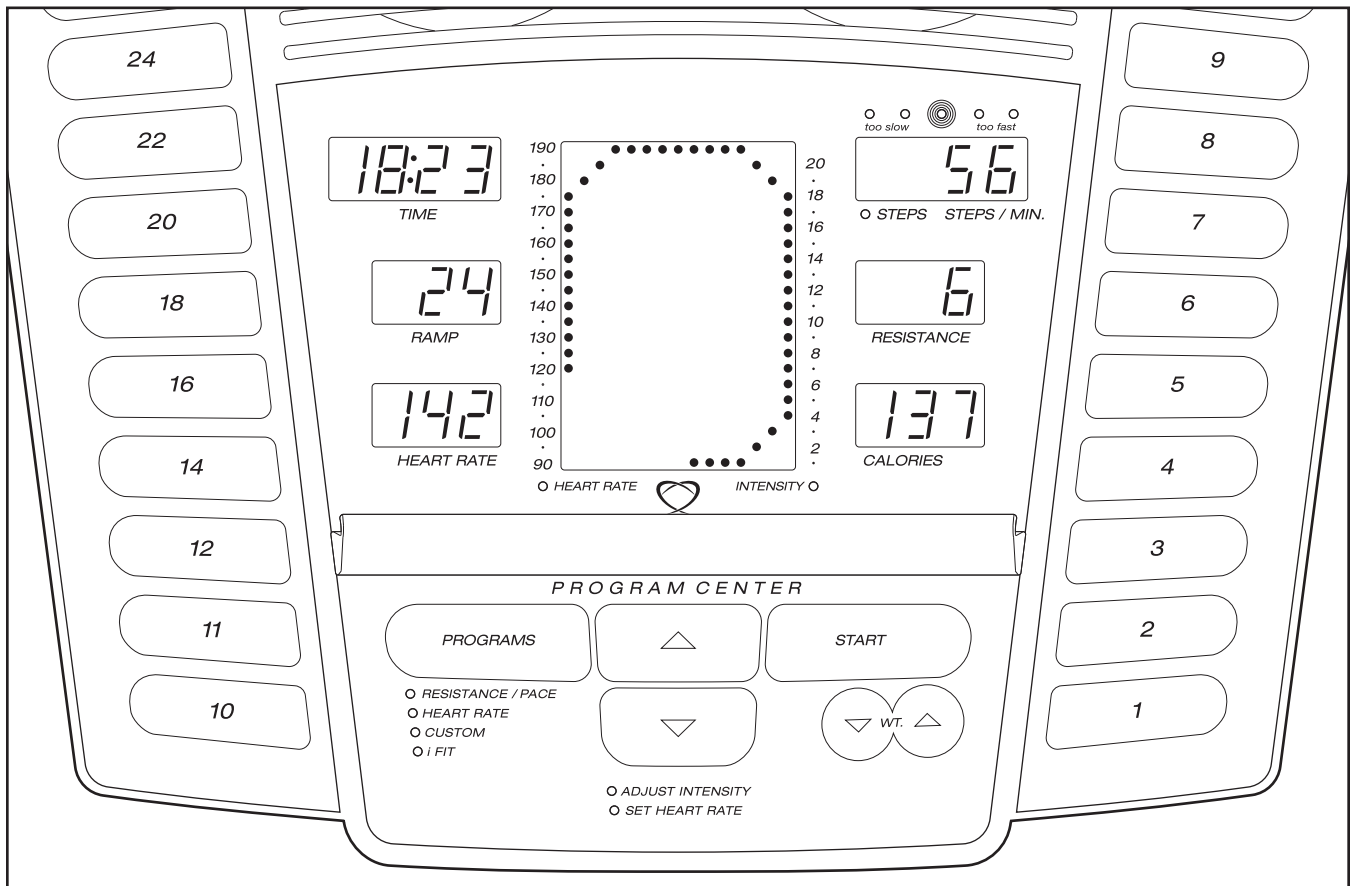

FEATURES OF THE CONSOLE

The advanced console offers a selection of features designed to make your workouts more enjoyable and effective. When the manual mode of the console is selected, the resistance of the pedals and the angle of the ramp can be changed with the touch of a button. As you pedal, the console will provide continuous exercise feedback. You can even measure your heart rate using the built-in handgrip pulse sensor.

In addition, the console offers eight preset programs. Each program automatically changes the resistance of the pedals and prompts you to increase or decrease your pace as it guides you through an effective workout.

The console also features two heart rate programs that automatically change the resistance of the pedals to keep your heart rate near a target heart rate as you exercise.

You can even create your own custom workout programs and save them in memory for future use.

The console also features iFIT.com interactive technology. Having iFIT.com interactive technology is like having a personal trainer in your home. Using the included

audio cable, you can connect the elliptical exerciser to your home stereo, portable stereo, computer, or VCR and play special iFIT.com CD and video programs (iFIT.com CDs and videocassettes are available separately). iFIT.com CD and video programs automatically control the resistance of the pedals and prompt you to vary your pace as a personal trainer coaches you through every step of your workout. High-energy music provides added motivation. **To purchase iFIT.com CDs and videocassettes, call the toll-free telephone number on the front cover of this manual.**

With the elliptical exerciser connected to your computer, you can also go to our Web site at www.iFIT.com and access programs directly from the internet. **Explore www.iFIT.com for more information.**

To use the manual mode of the console, see page 11. To use a preset program, see page 13. To use a heart rate program, see page 14. To create and use a custom program, see page 16. To use an iFIT.com CD or video program, see page 20. To use a program directly from our Web site, see page 21.

HOW TO USE THE MANUAL MODE

1 Turn on the console.

To turn on the console, press any button or begin pedaling. Note: If there are sheets of clear plastic on the face of the console, remove the plastic.

2 Select the manual mode.

When the power is turned on, the manual mode will be selected. If you have selected a program or the iFIT.com mode, reselect the manual mode by pressing the Programs button repeatedly until no program indicators are lit.

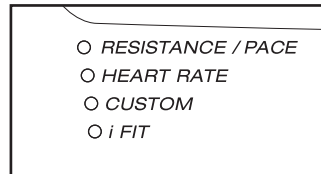

3 Begin pedaling and change the resistance of the pedals as desired.

As you pedal, change the resistance of the pedals by pressing the Quick Resistance buttons. Note: After the buttons are pressed, it will take a moment for the pedals to reach the selected resistance level.

4 Adjust the angle of the ramp as desired.

As you pedal, change the angle of the ramp by pressing the Quick Ramp buttons. Note: After the buttons are pressed, it will take a moment for the ramp to reach the selected angle. If the ramp does not function properly, see HOW TO CALIBRATE THE INCLINE SYSTEM on page 22.

5 Monitor your progress with the displays.

The matrix— When the manual mode or the iFIT.com mode is selected, the matrix will show a track representing 1/4 mile. As you exercise, the indicators around the track will light in succession until the entire track is lit. The track will then darken and the indicators will again begin to light in succession.

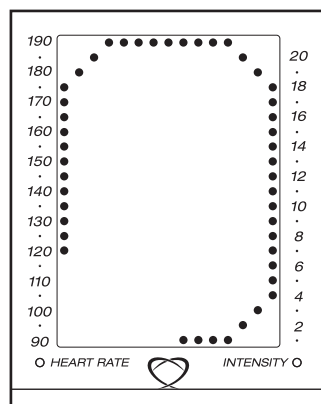

The Time display

will show the elapsed time. Note: When a program is selected, the display will show the time remaining in the program instead of the elapsed time.



The Ramp display

will show the angle of the ramp.

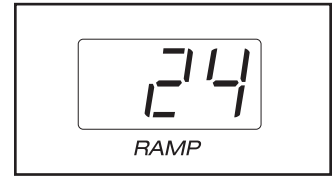

The Heart Rate display

will show your heart rate when you use the handgrip pulse sensor (see step 6 on page 12).

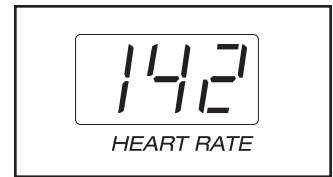

The Steps display

will show the total number of steps you have pedaled and your pedaling pace, in steps per minute. The display will change from one number to the other every few seconds.



The Resistance display will show the resistance level of the pedals.



The Calories display

will show the approximate number of calories you have burned. Note: For a more accurate reading, enter your weight by pressing the Weight (WT.) increase and decrease buttons until your weight is shown in the Calories display. Your weight will be saved in memory.



6 Measure your heart rate if desired.

If there are thin sheets of plastic on the metal contacts on the handgrip pulse sensor, peel off the plastic.

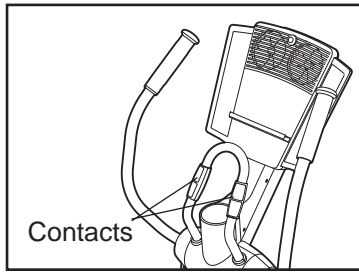

Place your hands on the handgrip pulse sensor, with your palms on the contacts. **Avoid moving your hands.** When your pulse is detected, one or two dashes will appear in the Heart Rate display and then your heart rate will be shown.

For the most accurate heart rate reading, continue to hold the handgrips for about 30 seconds.

If your heart rate is not shown, make sure that your hands are positioned as described. Avoid moving your hands excessively or squeezing the metal contacts too tightly. For optimal performance, periodically clean the metal contacts using a soft cloth; **never use alcohol, abrasives, or chemicals.**

7 Turn on the fans if desired.

To turn on the fans at low speed, press the fans button. To turn on the fans at high speed, press the button a second time. To turn off the fans, press the button a third time.

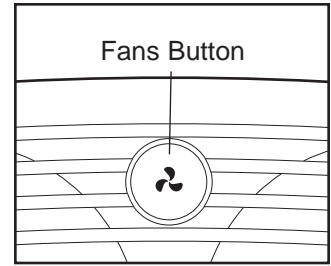

Note: If the fans are turned on but the pedals are not moved for thirty seconds, the fans will automatically turn off.

8 When you are finished exercising, the console will automatically turn off.

If the pedals are not moved for a few seconds, a series of tones will sound, the Time display will begin to flash, and the console will pause.

If the pedals are not moved for a few minutes, the console will turn off and the displays will be reset.

HOW TO USE A PRESET PROGRAM

1 Turn on the console.

See step 1 on page 11.

2 Select one of the eight preset programs.

To select one of the eight preset programs, press the Programs button repeatedly until the

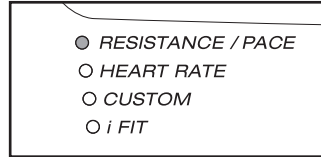

Resistance/Pace indicator lights. As each preset program is selected, a profile of the resistance settings of the selected program will scroll across the matrix. The Time display will show how long the program will last. The maximum resistance setting for the program will flash in the Resistance display for a few seconds.

3 Press the Start button or begin pedaling to start the program.

Each program is divided into 20, 30, or 45 one-minute segments. One resistance setting and one pace setting are programmed for each segment. Note: The same resistance setting and/or target pace may be programmed for two or more consecutive segments.

When you start the program, the resistance setting for the first segment will be shown in the flashing Current Segment column of the matrix. The resistance settings for the next twelve segments will be shown in the columns to the right.

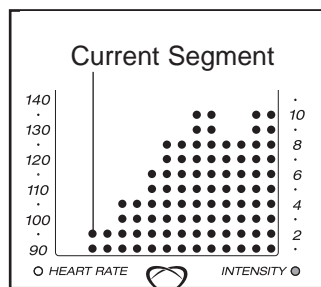

When only three seconds remain in the first segment of the program, both the Current Segment column and the column to the right will flash, a series of tones will sound, and the time will flash in the Time display. When the first segment ends, *all resistance settings will move one column to the left*. The resistance setting for the second segment will then be shown in the flashing Current Segment column and the resistance of the pedals will automatically change to the resistance setting for the second segment.

The program will continue until no time remains in the Time display.

4 Adjust the intensity level of the program if desired.

To increase or decrease the intensity level of the program, press the increase and decrease buttons above the Adjust Intensity indicator. If you change the intensity level, the profile in the matrix will show the new resistance settings.

5 Use the pace guide to pace your exercise.

Throughout the program, the pace guide will prompt you to increase or decrease your pedaling pace. When one of the indicators on the left side of the pace guide lights, increase your pace; when one of the indicators on the right

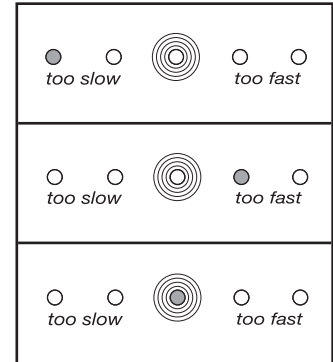

side lights, decrease your pace. When the center indicator lights, maintain your current pace.

Important: The pace guide is intended only to provide a goal. Make sure to pedal at a pace that is comfortable for you.

If you stop pedaling for several seconds, a tone will sound and the program will pause. To restart the program, simply resume pedaling.

6 Adjust the angle of the ramp as desired.

See step 4 on page 11.

7 Monitor your progress with the displays.

See step 5 on page 11.

8 Measure your heart rate if desired.

See step 6 on page 12.

9 Turn on the fans if desired.

See step 7 on page 12.

10 When you are finished exercising, the console will automatically turn off.

See step 8 on page 12.

HOW TO USE A HEART RATE PROGRAM

Each heart rate program helps you to keep your heart rate near a target heart rate during your workout.

Follow the steps below to use a heart rate program.

1 Turn on the console.

See step 1 on page 11.

2 Select one of the two heart rate programs.

To select one of the two heart rate programs, press the Programs button repeatedly until the Heart Rate indicator lights.

- RESISTANCE / PACE
- HEART RATE
- CUSTOM
- i FIT

As each heart rate program is selected, a profile of the target heart rate settings of the selected program will scroll across the matrix. The Time display will show how long the program will last.

3 Enter a maximum target heart rate setting.

When a heart rate program is selected, the current maximum target heart rate setting will be shown in the Heart Rate display. If desired, press the increase and decrease buttons to change the maximum target heart rate setting (see **EXERCISE INTENSITY on page 23**). If you change the maximum target heart rate setting, the profile will change to show the new target heart rate settings.

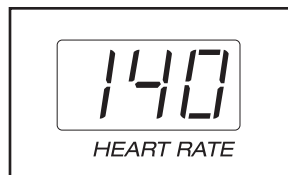

4 Hold the handgrip pulse sensor.

To use a heart rate program, you must use the handgrip pulse sensor (see step 6 on page 12). It is not necessary to hold the handgrips continuously during the program. However, you should

hold the handgrips frequently for the program to operate properly. **Each time you hold the handgrips, keep your hands on the metal contacts for at least 30 seconds.** Note: When you are not holding the handgrips, the letters PLS will flash in the Heart Rate display instead of your heart rate.

5 Press the Start button to start the program.

Each heart rate program is divided into 30 one-minute segments. One target heart rate setting is programmed for each segment. Note: The same target heart rate setting may be programmed for two or more consecutive segments.

The target heart rate setting for the first segment will be shown in the flashing Current Segment column of the matrix. The target heart rate settings for the next twelve segments will be shown in the columns to the right.

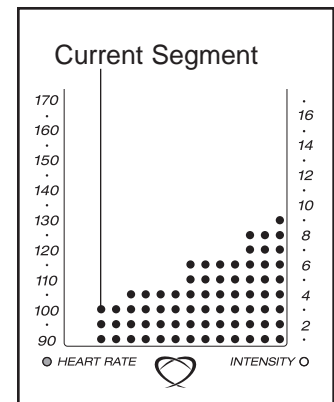

When only three seconds remain in the first segment of the program, both the Current Segment column and the column to the right will flash, a series of tones will sound, and *all target heart rate settings will move one column to the left*. The target heart rate setting for the second segment will then be shown in the flashing Current Segment column.

As you pedal, the console will regularly compare your heart rate to the target heart rate setting. If your heart rate is too far below or above the target heart rate setting, the resistance of the pedals will automatically increase or decrease to bring your heart rate closer to the target heart rate setting.

The pace guide will prompt you to increase or decrease your pedaling pace. When one of the indicators on the left side of the pace guide lights, increase your pace; when one of the indicators on the right side lights, decrease your pace. When the center indicator lights, maintain your current pace.

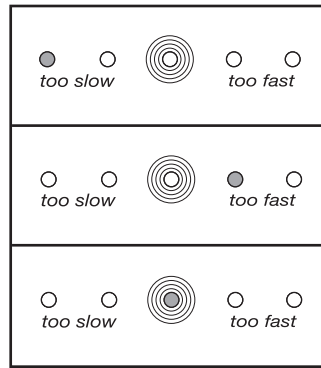

Important: The target heart rate settings are intended only to provide motivation. Your actual heart rate may be slower than the target heart rate settings. Make sure to exercise at a pace that is comfortable for you.

The program will continue until the target heart rate setting for the last segment is shown in the Current Segment column of the matrix and the last segment ends.

Note: During the program, you can manually override the resistance setting for the current segment, if desired, with the Quick Resistance buttons. However, when the console compares your

heart rate to the target heart rate setting, the resistance of the elliptical exerciser may automatically increase or decrease to bring your heart rate closer to the target heart rate setting.

If you stop pedaling for several seconds, a tone will sound and the program will pause. To restart the program, simply resume pedaling.

6 Adjust the angle of the ramp as desired.

See step 4 on page 11.

7 Monitor your progress with the displays.

See step 5 on page 11.

8 Turn on the fans if desired.

See step 7 on page 12.

9 When the program is finished, the console will automatically turn off.

See step 8 on page 12.

HOW TO CREATE AND USE A CUSTOM PROGRAM

1 Turn on the console.

See step 1 on page 11.

2 Select one of the two custom programs.

To select one of the two custom programs, press the Programs button repeatedly until the Custom indicator lights.

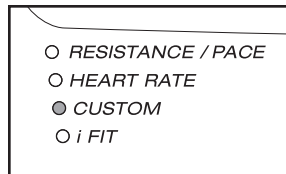

Note: If the custom program has not yet been defined, see step 3 to create the program. If the program is already defined, see step 4 to use the program.

3 Press the Start button or begin pedaling to create the program.

Refer to the matrix. Each custom program is divided into 40 one-minute segments. One resistance setting and one pace setting can be programmed for each segment. The resistance setting for the first segment will be shown in the flashing Current Segment column of the matrix. (The pace settings are not shown in the matrix.) To program a resistance setting and a pace setting for the first segment, simply adjust the resistance of the pedals as desired by pressing the Quick Resistance buttons, and pedal at the desired pace.

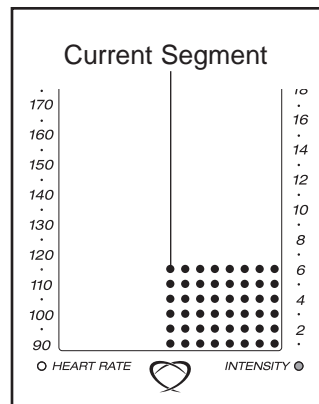

When the first segment of the program ends, a series of tones will sound and the current resistance setting and the current pace setting will be

saved in memory. *The columns of indicators will then move one column to the left, and the resistance setting for the second segment will be shown in the flashing Current Segment column.* Program a resistance setting and a pace setting for the second segment as described above.

Continue programming resistance and pace settings for as many segments as desired; custom programs can have up to 40 segments. The resistance and pace settings that you have programmed will be saved in memory.

4 Press the Start button or begin pedaling to start the program.

The custom program will function in almost the same way as a preset program (see steps 3 and 5 on page 13).

If desired, you can redefine the program while using it. **To change the resistance or pace setting for the current segment**, simply press the Quick Resistance buttons or change your pedaling pace to the new desired pace. When the current segment ends, the new setting will be saved in memory.

5 Adjust the angle of the ramp as desired.

See step 4 on page 11.

6 Monitor your progress with the displays.

See step 5 on page 11.

7 Measure your heart rate if desired.

See step 6 on page 12.

8 Turn on the fans if desired.

See step 7 on page 12.

9 When you are finished exercising, the console will automatically turn off.

See step 8 on page 12.

HOW TO CONNECT YOUR CD PLAYER, VCR, OR COMPUTER

To use **iFIT.com CDs**, the elliptical exerciser must be connected to your portable CD player, portable stereo, home stereo, or computer with CD player. See pages 17 and 18 for connecting instructions. To use **iFIT.com videocassettes**, the elliptical exerciser must be connected to your VCR. See page 19 for connecting instructions. To use **iFIT.com programs directly from our Web site**, the elliptical exerciser must be connected to your home computer. See page 18 for connecting instructions.

HOW TO CONNECT YOUR PORTABLE CD PLAYER

Note: If your CD player has separate **LINE OUT** and **PHONES** jacks, see instruction A below. If your CD player has only one jack, see instruction B.

- A. Plug one end of the audio cable into the jack beneath the console. Plug the other end of the cable into the **LINE OUT** jack on your CD player. Plug your headphones into the **PHONES** jack.

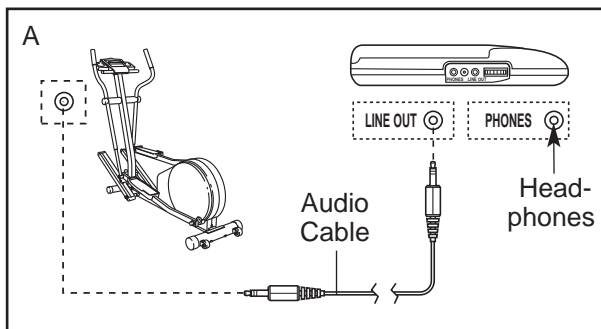

- B. Plug one end of the audio cable into the jack beneath the console. Plug the other end of the cable into a 1/8" Y-adaptor (available at electronics stores). Plug the Y-adaptor into the **PHONES** jack on your CD player. Plug your headphones into the other side of the Y-adaptor.

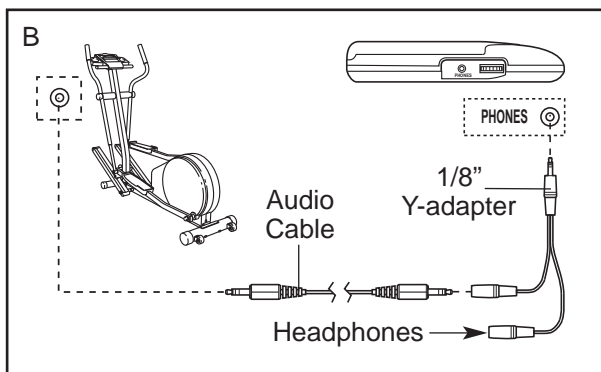

HOW TO CONNECT YOUR PORTABLE STEREO

Note: If your stereo has an **RCA-type AUDIO OUT** jack, see instruction A below. If your stereo has a 1/8" **LINE OUT** jack, see instruction B. If your stereo has only a **PHONES** jack, see instruction C.

- A. Plug one end of the audio cable into the jack beneath the console. Plug the other end of the cable into the adapter. Plug the adapter into an **AUDIO OUT** jack on your stereo.

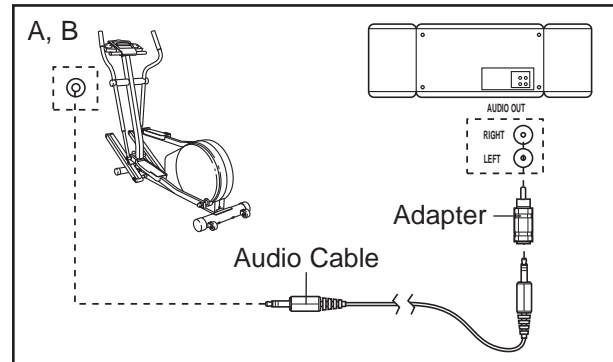

- B. Plug one end of the audio cable into the jack beneath the console. Plug the other end of the cable into the **LINE OUT** jack on your stereo. Do not use the adapter.

- C. Plug one end of the audio cable into the jack beneath the console. Plug the other end of the cable into a 1/8" Y-adaptor (available at electronics stores). Plug the Y-adaptor into the **PHONES** jack on your stereo. Plug your headphones into the other side of the Y-adaptor.

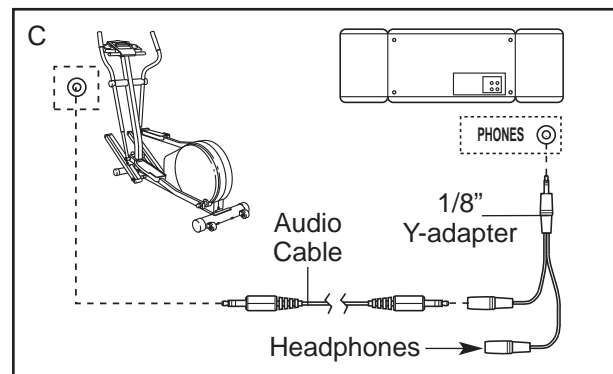

HOW TO CONNECT YOUR HOME STEREO

Note: If your stereo has an unused **LINE OUT** jack, see instruction A below. If the **LINE OUT** jack is being used, see instruction B.

- A. Plug one end of the audio cable into the jack beneath the console. Plug the other end of the cable into the adapter. Plug the adapter into the **LINE OUT** jack on your stereo.

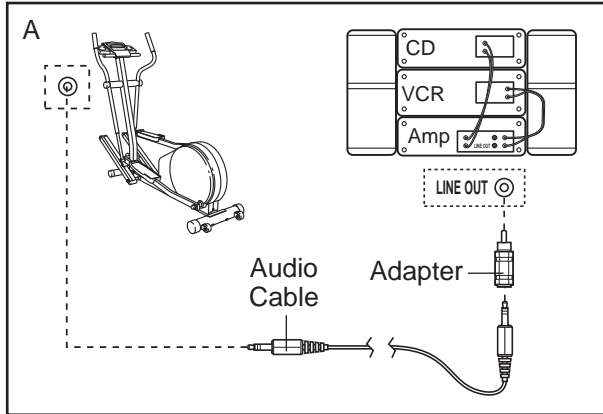

- B. Plug one end of the audio cable into the jack beneath the console. Plug the other end of the cable into the adapter. Plug the adapter into an **RCA Y-adapter** (available at electronics stores). Next, remove the wire that is currently plugged into the **LINE OUT** jack on your stereo and plug the wire into the unused side of the Y-adapter. Plug the Y-adapter into the **LINE OUT** jack on your stereo.

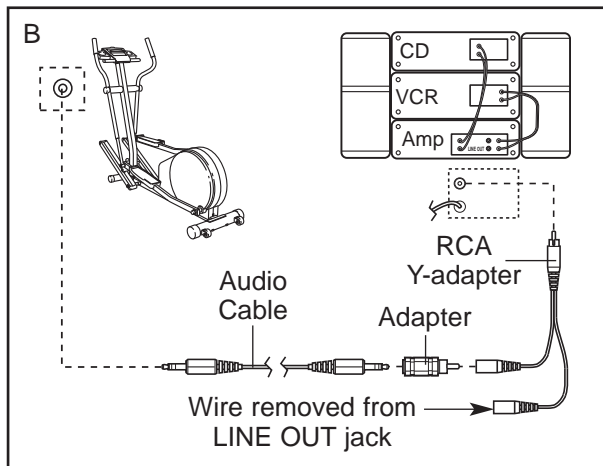

HOW TO CONNECT YOUR COMPUTER

Note: If your computer has a **1/8" LINE OUT** jack, see instruction A. If your computer has only a **PHONES** jack, see instruction B.

- A. Plug one end of the audio cable into the jack beneath the console. Plug the other end of the cable into the **LINE OUT** jack on your computer.

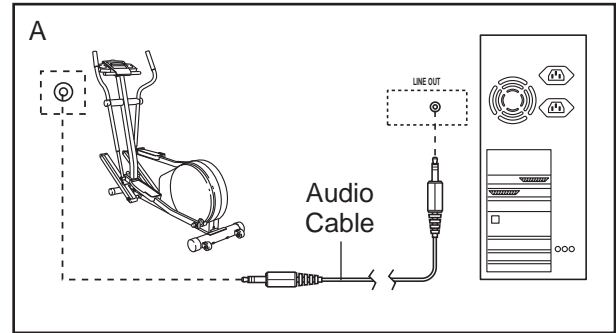

- B. Plug one end of the audio cable into the jack beneath the console. Plug the other end of the cable into a **1/8" Y-adapter** (available at electronics stores). Plug the Y-adapter into the **PHONES** jack on your computer. Plug your headphones or speakers into the other side of the Y-adapter.

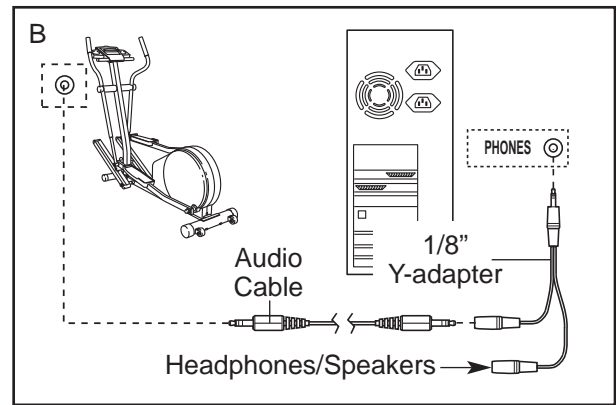

HOW TO CONNECT YOUR VCR

Note: If your VCR has an unused AUDIO OUT jack, see instruction A below. If the AUDIO OUT jack is being used, see instruction B. If you have a TV with a built-in VCR, see instruction B. If your VCR is connected to your home stereo, see HOW TO CONNECT YOUR HOME STEREO on page 18.

- A. Plug one end of the audio cable into the jack beneath the console. Plug the other end of the cable into the adapter. Plug the adapter into the AUDIO OUT jack on your VCR.

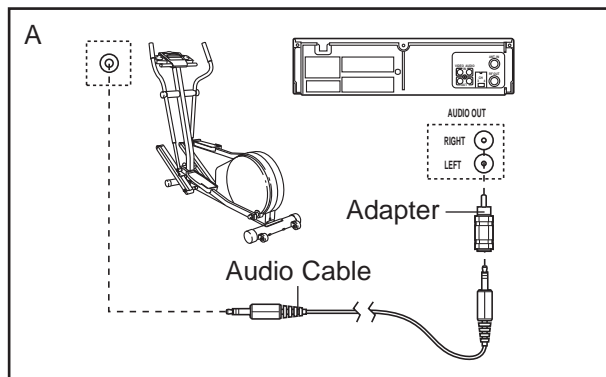

- B. Plug one end of the audio cable into the jack beneath the console. Plug the other end of the cable into the adapter. Plug the adapter into an RCA Y-adapter (available at electronics stores). Next, remove the wire that is currently plugged into the AUDIO OUT jack on your VCR and plug the wire into the unused side of the Y-adapter. Plug the Y-adapter into the AUDIO OUT jack on your VCR.

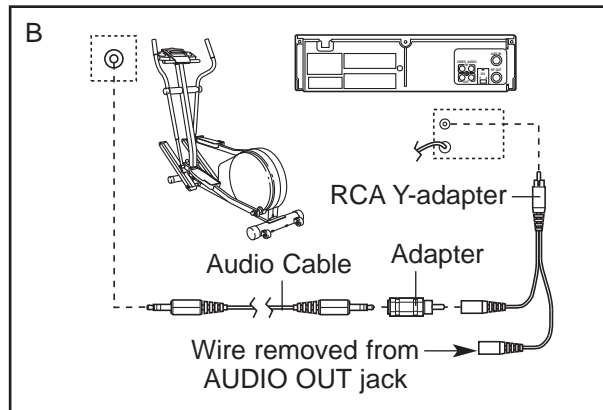

HOW TO USE iFIT.COM CD AND VIDEO PROGRAMS

To use iFIT.com CDs or videocassettes, the elliptical exerciser must be connected to your portable CD player, portable stereo, home stereo, computer with CD player, or VCR. See HOW TO CONNECT YOUR CD PLAYER, VCR, OR COMPUTER on pages 17 to 19. **To purchase iFIT.com CDs and videocassettes, call the toll-free telephone number on the front cover of this manual.**

Follow the steps below to use an iFIT.com CD or video program.

1 Turn on the console.

See step 1 on page 11.

2 Select the iFIT.com mode.

To select the iFIT.com mode, press the Programs button repeatedly until the iFIT indicator lights.

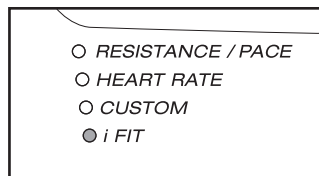

3 Insert the iFIT.com CD or videocassette.

If you are using an iFIT.com CD, insert the CD into your CD player. If you are using an iFIT.com videocassette, insert the videocassette into your VCR.

4 Press the play button on your CD player or VCR.

A moment after the play button is pressed, your personal trainer will begin guiding you through

your workout. Simply follow your personal trainer's instructions.

The program will function in almost the same way as a preset program (see steps 3 and 5 on page 13). However, an electronic "chirping" sound will alert you when the resistance of the pedals and/or the pace guide is about to change.

Note: If the resistance of the pedals and/or the pace guide does not change when a "chirp" is heard:

- Make sure that the iFIT indicator is lit.
- Adjust the volume of your CD player or VCR. If the volume is too high or too low, the console may not detect the program signals.
- Make sure that the audio cable is properly connected and that it is fully plugged in.

5 Adjust the angle of the ramp as desired.

See step 4 on page 11.

6 Monitor your progress with the displays.

See step 5 on page 11.

7 Measure your heart rate if desired.

See step 6 on page 12.

8 Turn on the fans if desired.

See step 7 on page 12.

9 When you are finished exercising, the console will automatically turn off.

See step 8 on page 12.

HOW TO USE PROGRAMS DIRECTLY FROM OUR WEB SITE

Our Web site at www.iFIT.com allows you to play iFIT.com programs directly from the internet. To use programs from our Web site, the elliptical exerciser must be connected to your home computer. See HOW TO CONNECT YOUR COMPUTER on page 18. In addition, you must have an internet connection and an internet service provider. A list of specific system requirements is found on our Web site.

Follow the steps below to use a program from our Web site.

1 Turn on the console.

See step 1 on page 11.

2 Select the iFIT.com mode.

To select the iFIT.com mode, press the Programs button repeatedly until the iFIT indicator lights.

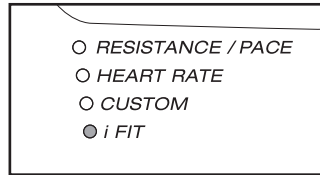

3 Go to your computer and start an internet connection.

4 Start your Web browser, if necessary, and go to our Web site at www.iFIT.com.

5 Follow the desired links on our Web site to select a program.

Read and follow the on-line instructions for using a program.

6 Follow the on-line instructions to start the program.

When you start the program, an on-screen countdown will begin.

7 Return to the elliptical exerciser and begin pedaling.

When the on-screen countdown ends, the program will begin. The program will function in almost the same way as a preset program (see steps 3 and 5 on page 13). However, an electronic “chirping” sound will alert you when the resistance of the pedals and/or the pace guide is about to change.

8 Adjust the angle of the ramp as desired.

See step 4 on page 11.

9 Monitor your progress with the displays.

See step 5 on page 11.

10 Measure your heart rate if desired.

See step 6 on page 12.

11 Turn on the fans if desired.

See step 7 on page 12.

12 When you are finished exercising, the console will automatically turn off.

See step 8 on page 12.

MAINTENANCE AND TROUBLESHOOTING

Inspect and properly tighten all parts of the elliptical exerciser regularly. Replace any worn parts immediately.

For smooth operation of the elliptical exerciser, **inspect and clean the ramp regularly** using a soft cloth and mild detergent. Other parts of the elliptical exerciser can also be cleaned in this way. **Keep liquids off the console. Never use abrasives or solvents.**

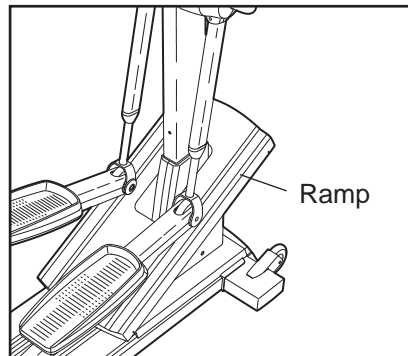

PULSE SENSOR TROUBLESHOOTING

If the handgrip pulse sensor does not function properly, see step 6 on page 12.

HOW TO CALIBRATE THE INCLINE SYSTEM

If the elliptical exerciser's incline system is not working properly, activate the calibration process by following the steps below.

1. Hold down the Start button and the increase button to the left of it at the same time for about five seconds. Note: Numbers may appear in the displays; disregard these numbers.
2. Press the Programs button. Note: A combination of letters and numbers will appear in the display.
3. Press the 30° Quick Ramp button. The ramp will rise to the highest position and then move down to the lowest position.
4. Press the Programs button three times. The console will then be in the normal operating mode and the elliptical exerciser will be ready for use.

HOW TO MOVE THE ELLIPTICAL EXERCISER

Stand behind the elliptical exerciser and hold the indicated handle firmly. Lift the handle until the elliptical exerciser can be moved on the front wheels, and carefully move the elliptical exerciser to the desired location. Then, carefully lower the elliptical exerciser. **Due to the size and weight of the elliptical exerciser, use extreme caution while lifting, moving, and lowering it.**

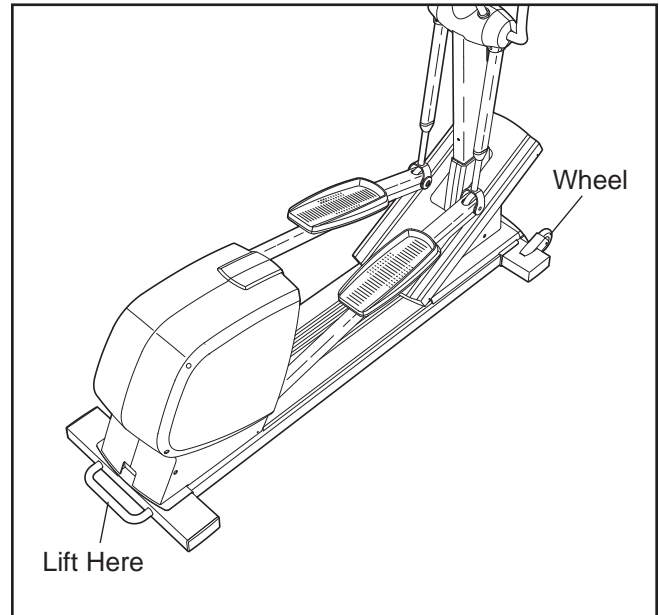

HOW TO LEVEL THE ELLIPTICAL EXERCISER

If the elliptical exerciser rocks during use, turn one or both of the leveling feet under the front stabilizer until the rocking motion is eliminated.

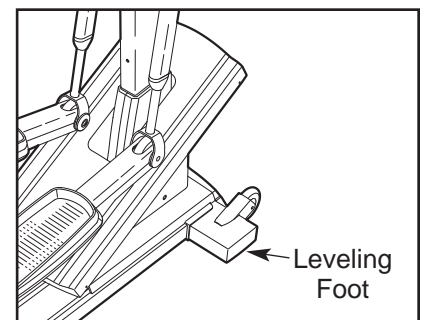

EXERCISE GUIDELINES

WARNING:



Before beginning this or any exercise program, consult your physician. This is especially important for persons over the age of 35 or persons with pre-existing health problems.

The pulse sensor is not a medical device. Various factors, including the user's movement, may affect the accuracy of heart rate readings. The pulse sensor is intended only as an exercise aid in determining heart rate trends in general.

The following guidelines will help you to plan your exercise program. Remember that proper nutrition and adequate rest are essential for successful results.

EXERCISE INTENSITY

Whether your goal is to burn fat or to strengthen your cardiovascular system, the key to achieving the desired results is to exercise with the proper intensity. The proper intensity level can be found by using your heart rate as a guide. The chart below shows recommended heart rates for fat burning, maximum fat burning, and cardiovascular (aerobic) exercise.

165	155	145	140	130	125	115	
145	138	130	125	118	110	103	
125	120	115	110	105	95	90	
20	30	40	50	60	70	80	

To find the proper heart rate for you, first find your age near the bottom of the chart (ages are rounded off to the nearest ten years). Next, find the three numbers above your age. The three numbers are your "training zone." The lower two numbers are recommended heart rates for fat burning; the highest number is the recommended heart rate for aerobic exercise.

Fat Burning

To burn fat effectively, you must exercise at a relatively low intensity level for a sustained period of time.

During the first few minutes of exercise, your body uses easily accessible *carbohydrate* calories for energy. Only after the first few minutes of exercise does your body begin to use stored *fat* calories for energy. If your goal is to burn fat, adjust the intensity of your exercise until your heart rate is near the lowest number in your training zone as you exercise.

For maximum fat burning, adjust the intensity of your exercise until your heart rate is near the middle number in your training zone as you exercise.

Aerobic Exercise

If your goal is to strengthen your cardiovascular system, your exercise must be "aerobic." Aerobic exercise is activity that requires large amounts of oxygen for prolonged periods of time. This increases the demand on the heart to pump blood to the muscles, and on the lungs to oxygenate the blood. For aerobic exercise, adjust the intensity of your exercise until your heart rate is near the highest number in your training zone as you exercise.

WORKOUT GUIDELINES

Each workout should include the following three parts:

A warm-up, consisting of 5 to 10 minutes of stretching and light exercise. A proper warm-up increases your body temperature, heart rate, and circulation in preparation for exercise.

Training zone exercise, consisting of 20 to 30 minutes of exercising with your heart rate in your training zone. (During the first few weeks of your exercise program, do not keep your heart rate in your training zone for longer than 20 minutes.)

A cool-down, with 5 to 10 minutes of stretching. This will increase the flexibility of your muscles and will help to prevent post-exercise problems.

EXERCISE FREQUENCY

To maintain or improve your condition, complete three workouts each week, with at least one day of rest between workouts. After a few months of regular exercise, you may complete up to five workouts each week if desired. The key to success is to make exercise a regular and enjoyable part of your everyday life.

PART LIST—MODEL NO. RBE0995.1

R1205A

Key No.	Qty.	Description	Key No.	Qty.	Description
1	1	Frame	53	4	Wheel Cap
2	1	Rear Stabilizer	54	1	"C" Magnet
3	1	Front Stabilizer	55	1	Spring
4	1	Upright	56	1	Power Cord
5	1	Ramp	57	1	Lower Wire Harness
6	1	Right Handlebar	58	1	Upper Wire Harness
7	1	Left Handlebar	59	1	Extension Wire Harness
8	1	Right Pedal Arm	60	1	Frame Plate
9	1	Left Pedal Arm	61	1	Rear Frame Plate
10	2	Pivot Shaft	62	4	Stabilizer Foot
11	1	Right Crank Arm	63	1	Incline Reed Switch
12	1	Left Crank Arm	64	1	Grommet
13	1	Right Rear Side Shield	65	2	Hairpin Cotter Pin
14	1	Left Rear Side Shield	66	1	Resistance Motor
15	1	Right Center Side Shield	67	1	Wedge
16	1	Left Center Side Shield	68	1	Incline Axle
17	1	Console	69	4	Ramp Bushing
18	1	Right Foot Rail	70	1	Power Receptacle
19	1	Left Foot Rail	71	1	Pulley Axle
20	2	Pivot Arm	72	2	Bearing Block Set
21	1	Front Left Pivot Cover	73	2	Large Snap Ring
22	1	Upright Cover	74	1	Crank Spacer
23	1	Water Bottle Holder	75	4	Pulley Spacer
24	2	Hand Grip	76	4	Bearing
25	2	Pulse Sensor/Wire	77	1	Idler Pulley
26	1	Pulse Sensor Bar	78	1	Idler Pulley Bracket
27	1	Front Center Pivot Cover	79	2	M8 x 39mm Button Screw
28	1	Rear Center Pivot Cover	80	1	M8 x 57mm Screw
29	1	Front Right Pivot Cover	81	1	Pillow Block
30	1	Rear Right Pivot Cover	82	5	M6 x 10mm Button Screw
31	1	Rear Left Pivot Cover	83	2	M6 Nut
32	2	Pivot Shaft Sleeve Set	84	1	M6 x 38mm Bolt
33	1	Upper Ramp Cap	85	11	M8 Split Washer
34	1	Lower Ramp Cap	86	2	Union Set
35	2	5mm Spacer	87	4	30mm Spacer
36	1	Right Motor Shield	88	4	M4 x 19mm Screw
37	1	Left Motor Shield	89	65	M4 x 16mm Screw
38	1	Front Shield	90	8	M8 x 13mm Button Screw
39	2	Pedal Assembly	91	6	M4 x 16mm Round Head Screw
40	1	Reed Switch/Wire	92	4	M4 x 30mm Screw
41	1	Snap Ring	93	4	M8 x 18mm Washer
42	4	Pedal Arm Bushing	94	4	M8 x 16mm Button Screw
43	4	Stabilizer Endcap	95	8	M8 x 65mm Button Screw
44	1	Pulley	96	1	M4 x 19mm Round Head Screw
45	1	Flywheel	97	2	M8 x 50mm Button Screw
46	1	Motor	98	2	Steel Washer
47	1	Transformer	99	2	Flange Screw
48	1	Power Board Bracket	100	1	M8 x 25mm Button Screw
49	1	Power Board	101	2	M8 16mm Washer
50	1	Power Board Bracket Cover	102	2	M6 Union Set
51	2	Wheel	103	5	M8 x 23mm Washer
52	2	Pedal Arm Wheel	104	1	M8 Nylon Locknut

Key No.	Qty.	Description	Key No.	Qty.	Description
105	1	Magnet Bracket Bolt	116	1	Long Clevis Pin
106	2	Frame Cushion	117	4	M5 x 16mm Bolt
107	1	Clamp	118	2	M8 x 20mm Button Screw
108	1	Reed Switch Bracket	119	2	M8 x 25mm Washer
109	1	M5 x 16mm Self-tapping Screw	120	10	M4 x 12mm Screw
110	2	M8 x 47mm Button Screw	121	1	Belt
111	4	8mm Plastic Spacer	122	1	Resistance Cable
112	1	Clevis Pin	123	4	M8 x 25mm Patch Screw
113	4	#8 x 9mm Screw	#	1	User's Manual
114	4	M5 Nylon Locknut	#	1	Exercise Guide
115	4	M5 Washer			

Note: “#” indicates a non-illustrated part. Specifications are subject to change without notice. See the back cover of this manual for information about ordering replacement parts.

EXPLODED DRAWING B—MODEL NO. RBE0995.1

R1205A

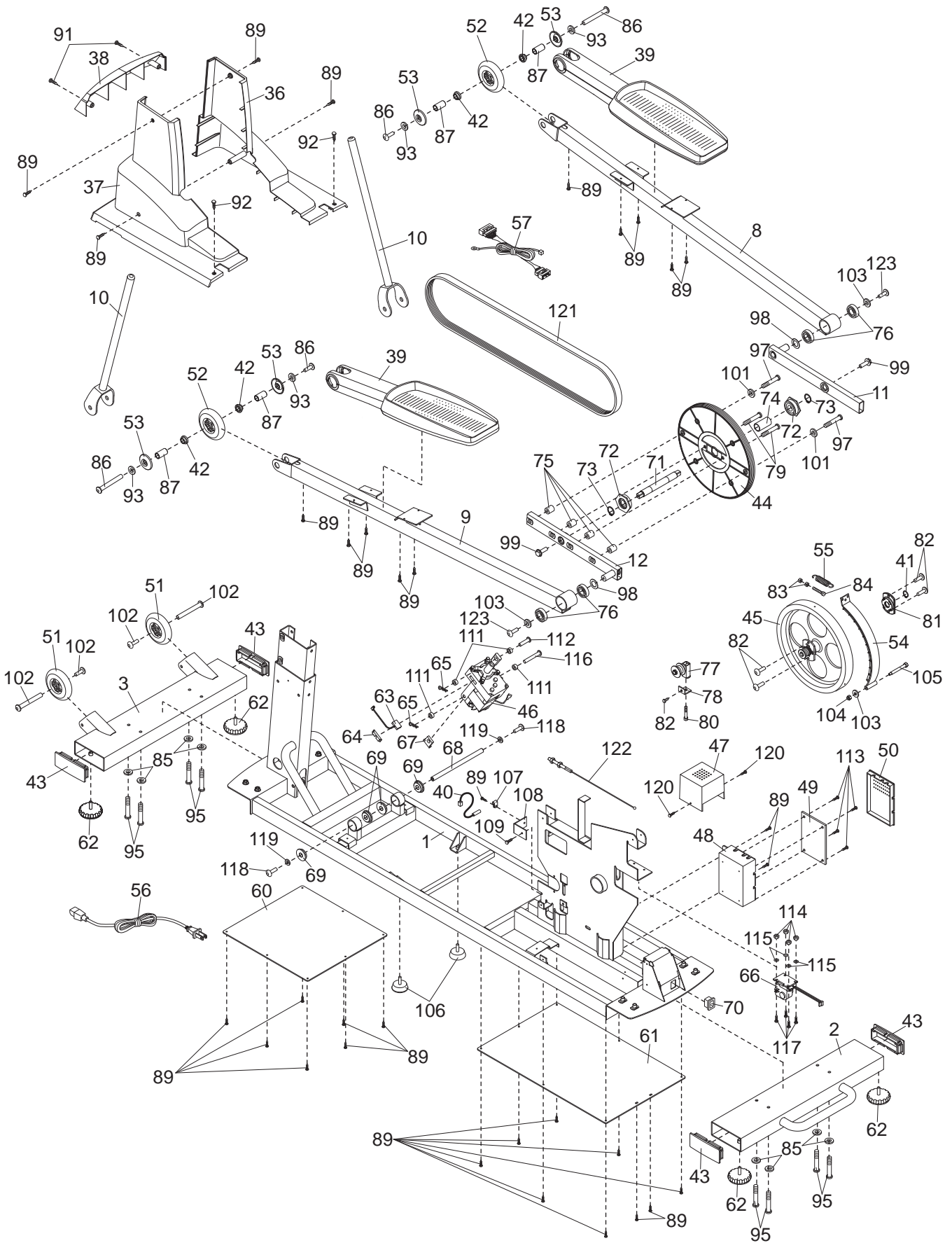

ORDERING REPLACEMENT PARTS

To order replacement parts, see the front cover of this manual. To help us assist you, please be prepared to give the following information:

- the MODEL NUMBER of the product (RBE0995.1)
- the NAME of the product (REEBOK RL 900 elliptical exerciser)
- the SERIAL NUMBER of the product (see the front cover of this manual)
- the KEY NUMBER and DESCRIPTION of the part(s) (see pages 24 to 27)

REEBOK and the Vector Logo  are registered trademarks and service marks of Reebok. This product is manufactured and distributed under license from Reebok International.

LIMITED WARRANTY

ICON Health & Fitness, Inc. (ICON), warrants this product to be free from defects in workmanship and material, under normal use and service conditions, for a period of one (1) year from the date of purchase. This warranty extends only to the original purchaser. ICON's obligation under this warranty is limited to replacing or repairing, at ICON's option, the product through one of its authorized service centers. All repairs for which warranty claims are made must be pre-authorized by ICON. If the product is shipped to a service center, freight charges to and from the service center will be the customer's responsibility. For in-home service, the customer will be responsible for a minimal trip charge. This warranty does not extend to any product or damage to a product caused by or attributable to freight damage, abuse, misuse, improper or abnormal usage or repairs not provided by an ICON authorized service center, products used for commercial or rental purposes, or products used as store display models. No other warranty beyond that specifically set forth above is authorized by ICON.

ICON is not responsible or liable for indirect, special or consequential damages arising out of or in connection with the use or performance of the product or damages with respect to any economic loss, loss of property, loss of revenues or profits, loss of enjoyment or use, costs of removal, installation or other consequential damages of whatsoever nature. Some states do not allow the exclusion or limitation of incidental or consequential damages. Accordingly, the above limitation may not apply to you.

The warranty extended hereunder is in lieu of any and all other warranties and any implied warranties of merchantability or fitness for a particular purpose is limited in its scope and duration to the terms set forth herein. Some states do not allow limitations on how long an implied warranty lasts. Accordingly, the above limitation may not apply to you.

This warranty gives you specific legal rights. You may also have other rights which vary from state to state.

ICON HEALTH & FITNESS, INC., 1500 S. 1000 W., LOGAN, UT 84321-9813