

Software: TC5.1
June 2012



PrecisionHD
1080p12x



PrecisionHD
1080p4x



PrecisionHD
1080p4xS2



PrecisionHD
720p

Cisco TelePresence PrecisionHD Camera User Guide

What's in this guide?

The top menu bar and the entries in the Table of Contents are all hyperlinks, just click on them to go to the topic.

We recommend you visit our web site regularly for updated versions of the user documentation. Go to: <http://www.cisco.com/go/telepresence/docs>

Table of Contents

Introduction	
About this guide	4
User documentation	4
The physical interface	
The PrecisionHD Camera 1080p12x	6
The PrecisionHD Camera 1080p4x	7
The PrecisionHD Camera 1080p4xS2	8
The PrecisionHD Camera 720p	9
Connecting the camera to the codec	
SX20 Codec configurations	11
Codec C20 configurations	11
Codec C40 configurations	11
Codec C60 configurations	12
Codec C90 configurations	12
Camera cables	13
HDMI cable	13
HD-SDI cable	13
HDMI to DVI-D adapter	13
Pin-out for cables	13
Pin out—Custom Plug Camera Cable	14
Pin out— Custom to HDMI and RJ45 Camera Cable	15
Pin out— Custom to HDMI and DB9P Camera Cable	16
Video output formats	
PrecisionHD 1080p12x	18
Video output formats	18
Line voltage frequency	18
DIP switch table	18
Daisy chaining the cameras	
Daisy chaining of the PrecisionHD 1080p12x	20
Daisy chaining of the PrecisionHD 720p	21
Daisy chaining of the PrecisionHD 1080p4x	22

Appendices

Controlling cameras using the VISCA™ protocol	24
RS-232 Commands and inquiries	24
The VISCA™/RS-232 control protocol	25
VISCA message format	25
Network and interface commands	26
Push messages	26
Camera commands	26
PTZF - movement commands	27
Inquiries	29
Software upload commands	30
Debug commands for Cisco cameras	30
Other commands	30
Video mode selection	31
DIP Switch settings	31
DIP switch table	31
Technical specifications	32
PrecisionHD Camera 1080p4x	32
PrecisionHD Camera 1080p4xS2	32
PrecisionHD Camera 1080p4x*	32
PrecisionHD Camera 1080p12x	33
PrecisionHD Camera 720p	33

Chapter 1 Introduction



PrecisionHD
1080p12x



PrecisionHD
1080p4x



PrecisionHD
1080p4xS2



PrecisionHD
720p

About this guide

The purpose of this document is to describe the camera matters specific to the PrecisionHD cameras. The guide is mainly focused on the PrecisionHD 1080p cameras. Some information about the PrecisionHD 720p is included.

Applies to the products listed below.:

- Cisco TelePresence PrecisionHD Camera – 1080p12x
- Cisco TelePresence PrecisionHD Camera – 1080p4x
- Cisco TelePresence PrecisionHD Camera – 1080p4xS2
- Cisco TelePresence PrecisionHD Camera – 720p

User documentation

The user documentation for the Cisco TelePresence systems, running the TC software, have several guides suitable to various user groups.

- Video conference room primer
- Video conference room acoustics guidelines
- Getting started guide for the TelePresence systems
- User guide for the TelePresence systems
- Administrator guides for the TelePresence systems
- Camera user guide for the PrecisionHD cameras
- API reference guides for the Codec C Series
- TC Console user guide for the Codec C Series
- Physical interfaces guides for the Codec C Series
- Regulatory compliance and safety information guides
- Legal & license information for products using TC software

Download the user documentation

Go to: ► <http://www.cisco.com/go/telepresence/docs> and select your product to see the user documentation for your product.

Chapter 2

The physical interface



PrecisionHD
1080p12x



PrecisionHD
1080p4x



PrecisionHD
1080p4xS2



PrecisionHD
720p

The PrecisionHD Camera 1080p12x

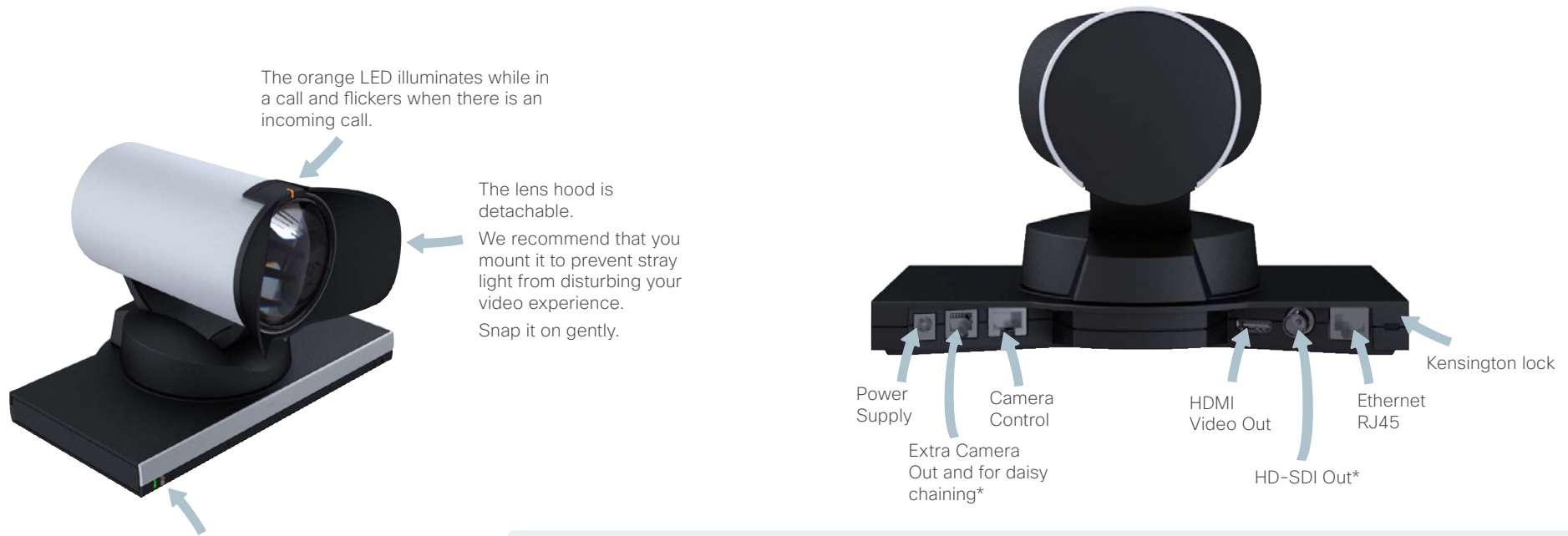

The orange LED illuminates while in a call and flickers when there is an incoming call.

The lens hood is detachable. We recommend that you mount it to prevent stray light from disturbing your video experience. Snap it on gently.

The green LED is continuously illuminated when power is On, but it flickers when receiving signals from the remote control. When mounted (upside down) in the Profile 65" and the Profile 65" Dual, the LED is not visible.

HDMI and HD-SDI

- HDMI is the main video source. The maximum resolution is 1080p60.
- HD-SDI* is the secondary video source. The maximum resolution is 1080p30.
- The HDMI and HD-SDI* can be used simultaneously. The maximum resolution is 1080p30, if you want both to run with the same resolution.

Camera control

Camera control is used for controlling the pan, tilt and zoom, and for powering up the camera.

Power

- When the camera is used with a Cisco Codec, power will be supplied through Camera Control cable.
- When the camera is used with non-Cisco codecs, you may have to connect power separately.

Extra camera

For multi-camera setup, e.g. when you connect cameras in daisy chain*:

- The first camera in the chain is powered by the camera control cable. The next must use the 12V DC Power in.
- Use an extra camera cable between the Extra Camera sockets.

Ethernet

For software upgrades on daisy chained cameras. Requires software version TC3.0 or higher on the Codec C-series.

Kensington lock

The Kensington lock may be used to prevent the camera to be moved from its place or to prevent theft.

* Not supported with Codec C20.

The PrecisionHD Camera 1080p4x

Available with the Cisco TelePresence Quick Set C20.

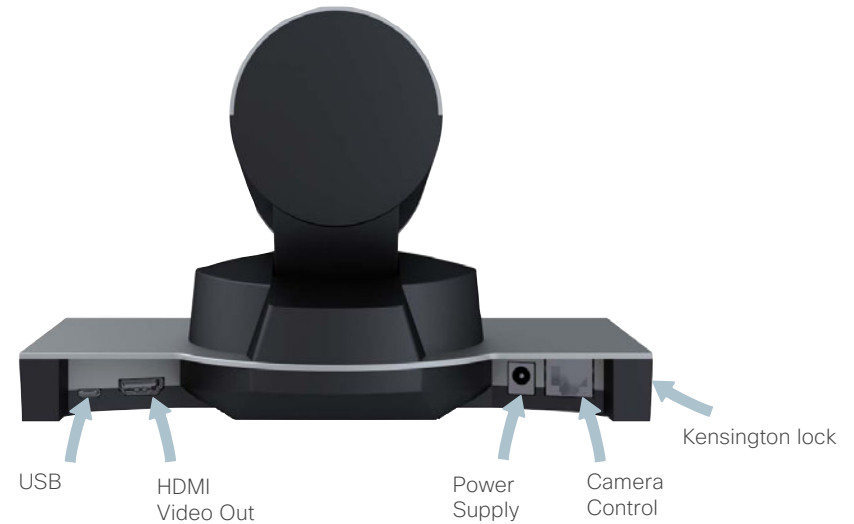

CAUTION! Do not pan or tilt the PrecisionHD 1080p4x camera by hand!

The Quick Set C20 is shipped with the PrecisionHD 1080p 4x camera.

NOTE: The early shipments of the Quick Set C20 came with an interim version of the PrecisionHD 1080p4x camera (the PrecisionHD 1080p4x* camera).

* Available for a limited period of time. See the ["Technical specifications" on page 32](#) section for details.

HDMI and Camera Control

HDMI video out

- HDMI is the video out source.
- PrecisionHD 1080p4x: Maximum resolution is 1080p30/720p60.

Camera control

Camera control is used for controlling the pan, tilt and zoom, and for powering up the camera.

Daisy-chain control is not supported. The camera can be used in a chain of multiple cameras but must be the last camera in the chain.

Power

Use the supplied power adapter when connecting the power.

USB

For future use.

Kensington lock

The Kensington lock may be used to prevent the camera to be moved from its place or to prevent theft.

The PrecisionHD Camera 1080p4xS2

Available with the Cisco TelePresence SX20 Quick Set.

The orange LED illuminates while in a call and flickers when there is an incoming call.

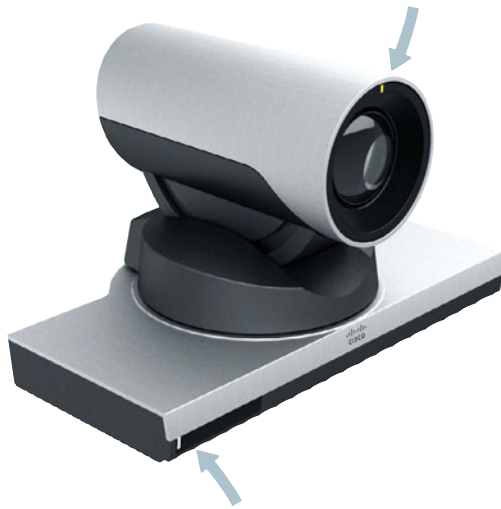

The LED is continuously illuminated when the system is in use. It flickers when the system receives signals from the remote control and blinks when rebooting. The LED pulsates when the system is in Standby mode.

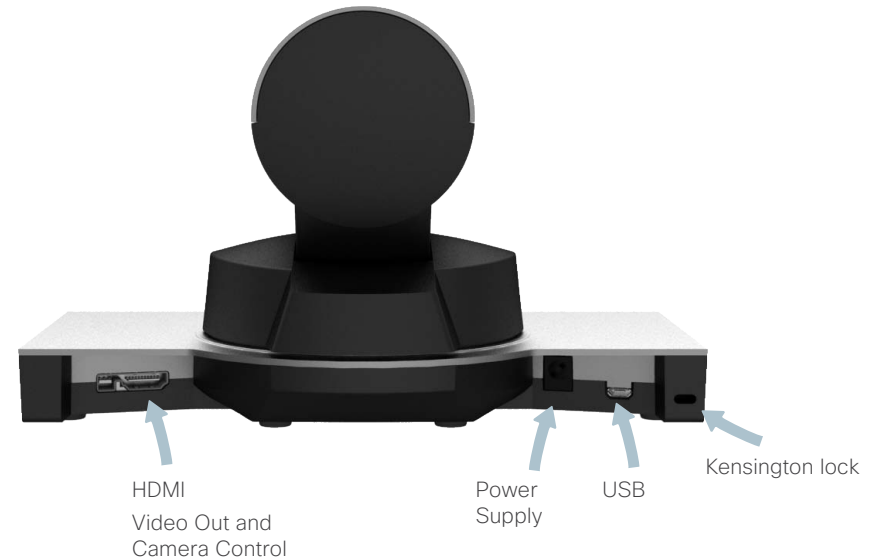

HDMI and Camera Control

Video Out

- HDMI is the video out source.
- PrecisionHD 1080p4xS2: Maximum resolution is 1080p60.

Camera control

Camera control is used for controlling the pan, tilt and zoom, and for powering up the camera.

Power

Use the supplied power adapter when connecting the power.

USB

For future use.

Kensington lock

The Kensington lock may be used to prevent the camera to be moved from its place or to prevent theft.

Pulsating	— — — — —
Blinking	- - - - -
Flickering

The PrecisionHD Camera 720p



The orange LED illuminates while in a call and flickers when there is an incoming call.

The lens hood (not mounted on the camera in the picture) is detachable. We recommend that you mount it to prevent stray light from disturbing your video experience. Snap it on gently.

The green LED is continuously illuminated when power is On, but it flickers when receiving signals from the remote control.



VISCA Daisy chain
Power in 12 V DC

HDMI video out
Camera control & Power
Kensington lock

HDMI

- HDMI is the main video source. The maximum resolution is 720p30.

Camera control

Camera control is used for controlling the pan, tilt and zoom, and for powering up the camera.

Power

- When the camera is used with a Cisco Codec, power will be supplied through Camera Control cable.
- When the camera is used with non-Cisco codecs, you may have to connect power separately.

Extra camera

If you want to connect cameras in a daisy chain*:

- The first camera in the chain is powered by the camera control cable. The next must use the 12V DC Power in.
- Use an extra camera cable between the Extra Camera sockets.

Kensington lock

The Kensington lock may be used to prevent the camera to be moved from its place or to prevent theft.

* Not supported with Codec C20

Chapter 3

Connecting the camera to the codec



PrecisionHD
1080p12x



PrecisionHD
1080p4x



PrecisionHD
1080p4xS2



PrecisionHD
720p

SX20 Codec configurations



Codec C20 configurations



Codec C40 configurations



Connecting to the PrecisionHD Camera 1080p4xS2

Connect the combined custom HDMI and camera control cable:

- From the **HD VIDEO OUT** connector on the 4xS2 camera.
- To the **CAMERA** connector on the SX20. Visca™ protocol is supported.

Connecting to a PrecisionHD Camera

Connect the HDMI cable:

- From the **HD VIDEO OUT** (HDMI) connector on the camera.
- To the **CAMERA** (HDMI) connector on the Codec C20.

Connect the camera control cable:

- From the **CODEC CONTROL IN** (RJ45) connector on the camera.
- To the **CAMERA CONTROL** (RS-232) connector on the Codec C20. Visca™ protocol is supported.

Connecting to a PrecisionHD Camera

Connect the HDMI cable:

- From the **HD VIDEO OUT** (HDMI) connector on the camera.
- To the **HDMI 1 IN** (HDMI) connector on the Codec C40.

Connect the camera control cable:

- From the **CODEC CONTROL IN** (RJ45) connector on the camera.
- To the **CAMERA CONTROL** (RS-232) connector on the Codec C40.

Codec connectors

Output connector
 Input connector

Codec C60 configurations



Connecting to a PrecisionHD Camera

Connect the HDMI cable:

- From the **HD VIDEO OUT** (HDMI) connector on the camera.
- To the **HDMI 1 IN** (HDMI) connector on the Codec C60.

Connect the camera control cable:

- From the **CODEC CONTROL IN** (RJ45) connector on the camera.
- To the **CAMERA CONTROL** (RS-232) connector on the Codec C60. Visca™ protocol is supported.

Codec C90 configurations



Connecting to a PrecisionHD Camera

Basic setup

Connect the HDMI cable:

- From the **HD VIDEO OUT** (HDMI) connector on the camera.
- To the **HDMI 1** (HDMI) connector on the Codec C90.

Connect the camera control cable:

- From the **CODEC CONTROL IN** (RJ45) connector on the camera.
- To the **CAMERA CONTROL** (RS-232) connector on the Codec C90. Visca™ protocol is supported.

Other configurations

The HDMI <1..4> and HD-SDI <1..4> connectors can be used for the camera. The HDMI and HD-SDI can be used simultaneously.

Connect the HD-SDI cable:

- From the **HD-VIDEO OUT** (HD-SDI) connector on the camera.
- To the **HD-SDI** <1..4> connector on the Codec C90.

Codec connectors

- Output connector
- Input connector

Camera cables

HDMI cable

The HDMI cable delivered with the camera is 5 meters. Maximum length is 15 meter with a category 2 certified good quality HDMI cable. This cable can be used with the C20, C40, C60 and C90 Codecs.

HD-SDI cable

The HD-SDI cable must be purchased separately. The maximum recommended length of HD-SDI cable is 100 meters. This cable can be used with the C90 Codec.

HDMI to DVI-D adapter

The HDMI to DVI-D adapter is used when connecting to a MXP Codec or Video Switch.

Pin-out for cables

If you must assemble your own cables, the tables show the pin-out required.

Pin-out–VISCA Camera control RJ45 8 pins shielded modular jack	
Pin	Signal name
8	+12V (2.8mA current source when connected in daisy chain)
7	GND
6	TXD (out)
5	NC (no connect)
4	NC (no connect)
3	RXD (in)
2	GND
1	+12V

Pin-out–VISCA Daisy chain RJ 11 6 pins modular jack	
Pin	Signal name
6	GND
5	GND
4	RXD (in)
3	TXD (out)
2	Presence (12V in daisy chain)
1	GND

Pin-out–Camera cable RJ45 (8 pin) to D-SUB			
Signal name	RJ45 pin		D-SUB pin
+12Vdc	1	Twisted pair	4
GND	2		5
RX	3	Twisted pair	2
TX	6		3
NC	4	Twisted pair	1
NC	5		6
GND	7	Twisted pair	5
+12Vdc	8		4

Pin out—Custom Plug Camera Cable

The custom cable is used when connecting a SX20 Codec to a PrecisionHD Camera 1080p4xS2.

Custom Plug		Custom Plug	
Pin#		Pin#	Signal Name
1		1	TMDS Data2+
3		3	TMDS Data2-
2		2	TMDS Data2 Shield
4		4	TMDS Data1+
6		6	TMDS Data1-
5		5	TMDS Data1 Shield
7		7	TMDS Data0+
9		9	TMDS Data0-
8		8	TMDS Data0 Shield
10		10	TMDS Clock+
12		12	TMDS Clock-
11		11	TMDS Clock Shield
14		14	Utility / HEAC+
19		19	Hot Plug Detect / HEAC-
17		17	DDC /CEC Ground/ HEAC Shield
13		13	CEC
15		15	SCL
16		16	SDA
18		18	+5V Power
20		20	+12V Power
21		21	GND
23		23	GND
22		22	RS232
24		24	RS232
Shell		Shell	Shell

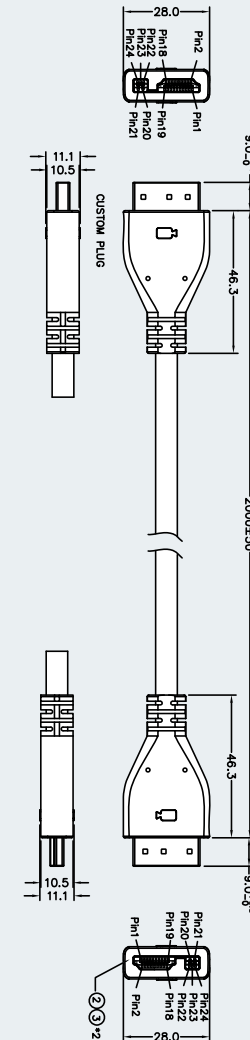

Pin out– Custom to HDMI and RJ45 Camera Cable

The custom plug to HDMI and RJ45 plugs cable is used when connecting a SX20 Codec to a PrecisionHD 1080p4x, 1080p12x and 720p cameras..

Custom Plug		HDMI Type A Plug	
Pin#		Pin#	Signal Name
1		1	TMDS Data2+
3		3	TMDS Data2-
2		2	TMDS Data2 Shield
4		4	TMDS Data1+
6		6	TMDS Data1-
5		5	TMDS Data1 Shield
7		7	TMDS Data0+
9		9	TMDS Data0-
8		8	TMDS Data0 Shield
10		10	TMDS Clock+
12		12	TMDS Clock-
11		11	TMDS Clock Shield
14		14	Utility / HEAC+
19		19	Hot Plug Detect / HEAC-
17		17	DDC /CEC Ground/ HEAC Shield
13		13	CEC
15		15	SCL
16		16	SDA
18		18	+5V Power
20		1	+12V Power
		8	+12V Power
21		2	GND
23		7	GND
22		3	RS232
24		6	RS232
Shell		Shell	Shell

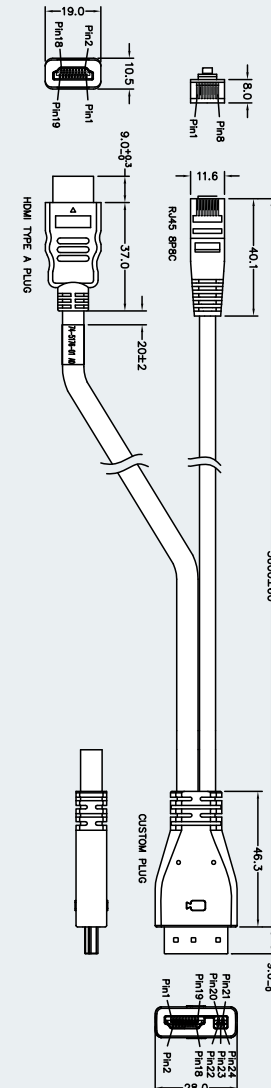

Pin out– Custom to HDMI and DB9P Camera Cable

The custom plug to HDMI and DB9Pm plugs cable is used when connecting a PrecisionHD Camera 1080p4xS2 to a C Series Codec.

Custom Plug		HDMI Type A Plug	
Pin#		Pin#	Signal Name
1		1	TMDS Data2+
3		3	TMDS Data2-
2		2	TMDS Data2 Shield
4		4	TMDS Data1+
6		6	TMDS Data1-
5		5	TMDS Data1 Shield
7		7	TMDS Data0+
9		9	TMDS Data0-
8		8	TMDS Data0 Shield
10		10	TMDS Clock+
12		12	TMDS Clock-
11		11	TMDS Clock Shield
14		14	Utility / HEAC+
19		19	Hot Plug Detect / HEAC-
17		17	DDC /CEC Ground/ HEAC Shield
13		13	CEC
15		15	SCL
16		16	SDA
18		18	+5V Power
20		4	+12V Power
21		5	GND
23			
22		3	RS232
24		2	RS232
Shell		Shell	Shell

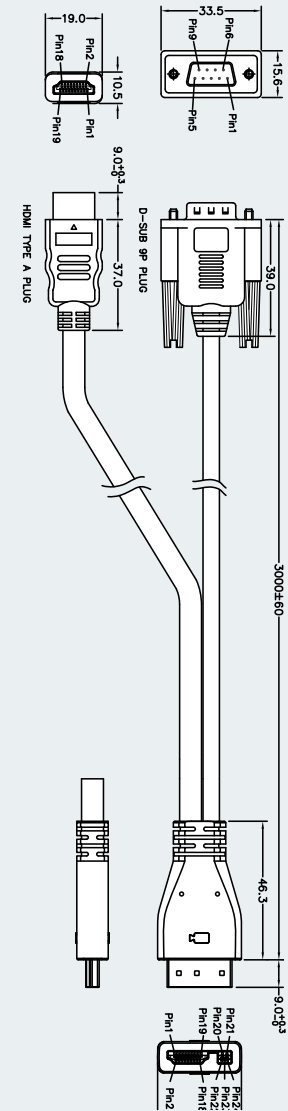

Chapter 4

Video output formats



PrecisionHD 1080p12x

PrecisionHD 1080p12x

The information on this page applies to the PrecisionHD 1080p12x camera. The camera has DIP switches for video output format setting.

NOTE: The early shipments of the Quick Set C20 came with an interim version of the PrecisionHD 1080p4x camera (the PrecisionHD 1080p4x* camera). The interim version has DIP switches for video output format setting, see the table on this page.

Video output formats

The DIP switches 1 to 5 sets the video output format for the camera. The DIP switches are located under the camera. The default setting is **Auto**, see the table to the right.

Maximum resolution:

- 1080p60 for PrecisionHD 1080p12x zoom
- 1080p30 for PrecisionHD 1080p4x* zoom
- 1080p30 for HD-SDI**

Line voltage frequency

The camera will automatically detect the line voltage frequency when it is 50 or 60Hz. If there is a different line voltage, you can set the video output format to a specific value (use the DIP switches) to override the auto frequency detection.

Set the PrecisionHD 1080p DIP switch (country specific setting):

- 50Hz: 00011, gives 1080p50 (720p50 for HD-SDI)
- 60Hz: 00100, gives 1080p60 (720p60 for HD-SDI)

DIP switch table

DIP Switch table for video output formats						
1	2	3	4	5	HDMI	HD-SDI**
0	0	0	0	0	Auto	
0	0	0	0	1	1920x1080p25	1920x1080p25
0	0	0	1	0	1920x1080p30	1920x1080p30
0	0	0	1	1	1920x1080p50**	1280x720p50***
0	0	1	0	0	1920x1080p60**	1280x720p60***
0	0	1	0	1	1280x720p25	1280x720p25
0	0	1	1	0	1280x720p30	1280x720p30
0	0	1	1	1	1280x720p50**	1280x720p50***
0	1	0	0	0	1280x720p60**	1280x720p60***
0	1	0	0	1	Software control	

The table shows the different settings available for the HDMI and the HD-SDI outputs.

Auto: Camera negotiates format over HDMI. HD-SDI tracks HDMI and defaults to 1080p30 in absence of HDMI sync.

Software: For more on the Software control setting, read about video mode selections in the Appendice section. Go to: ► [Controlling cameras using the VISCA™ protocol.](#)

PrecisionHD 1080p12x, from below

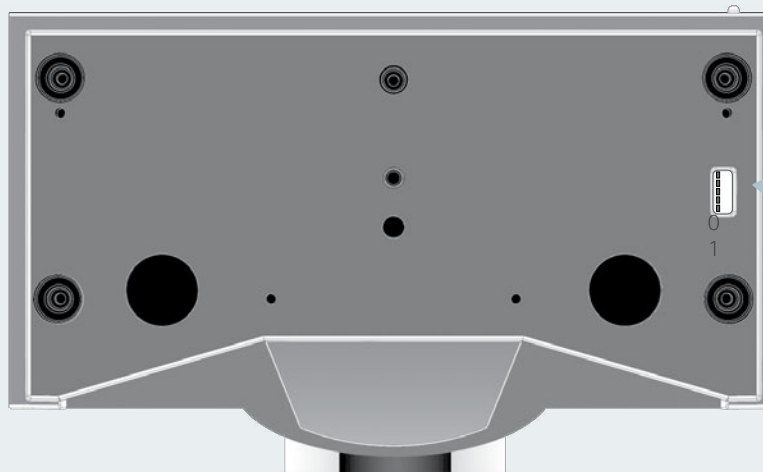

The DIP switches 1 to 5

* Available for a limited period of time.

** Not supported with Codec C20.

*** Do not use with the PrecisionHD 1080p4x* camera.

Chapter 5

Daisy chaining the cameras



PrecisionHD
1080p12x



PrecisionHD
1080p4x



PrecisionHD
1080p4xS2



PrecisionHD
720p

Daisy chaining of the PrecisionHD 1080p12x

A single daisy chain with PrecisionHD 1080p12x can have:

- Three cameras when using Codec C60.
- Seven cameras when using Codec C90.

Locate the Extra Camera and Power connectors.

- Power. The first camera in the chain is powered up from the codec by the VISCA camera control cable. Additional cameras must use the 12V DC Power in.
- Extra camera cable. The daisy chained cameras are connected by using the VISCA Extra Camera cable (maximum length 20 m / 65.6 ft) between the Extra Camera In and Codec Control In sockets.
- HDMI and HD-SDI. The HDMI and HD-SDI outputs can be used simultaneously on the same camera.

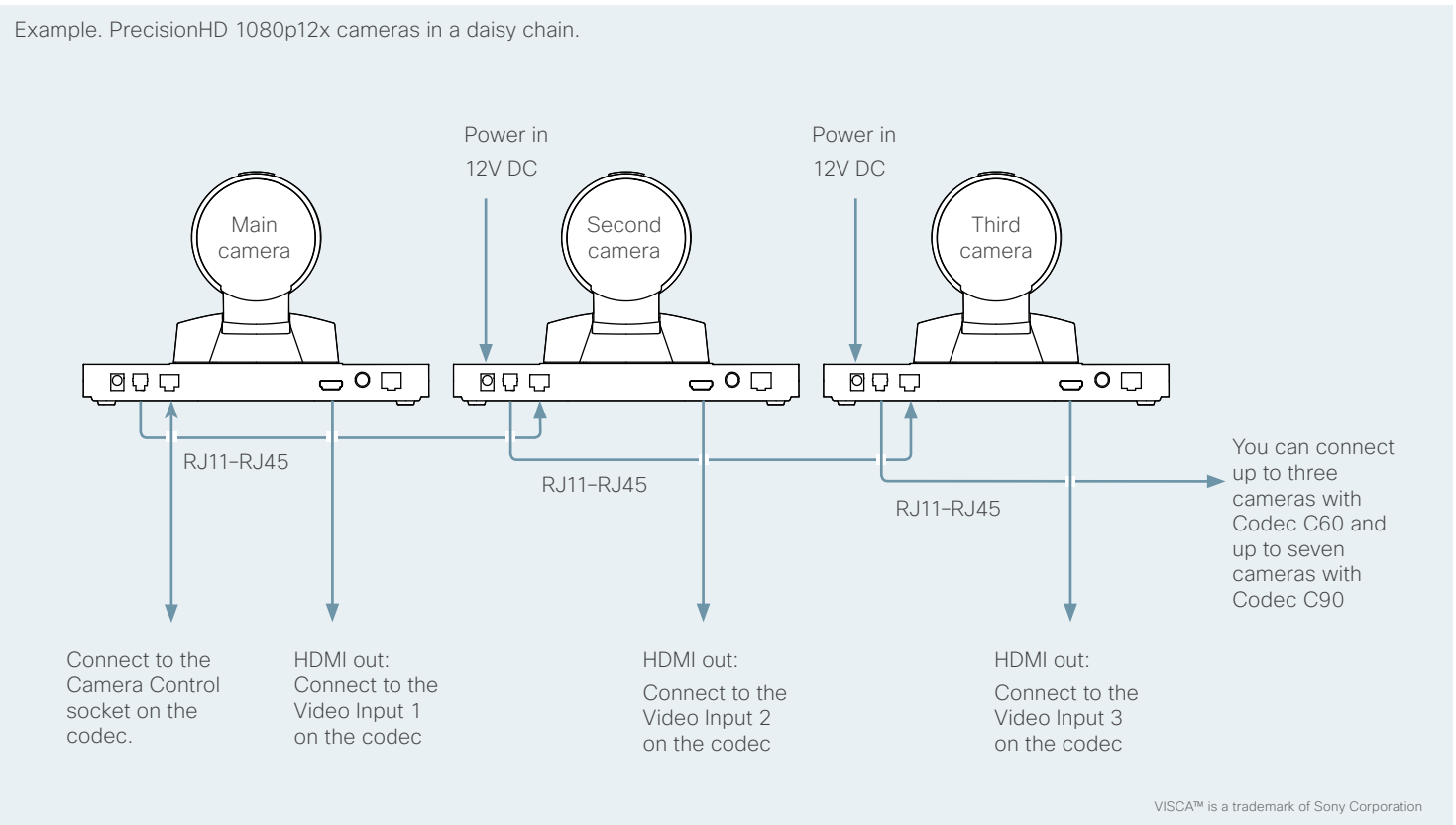

Daisy chaining of the PrecisionHD 720p

A single daisy chain can have:

- Three cameras when using Codec C60
- Seven cameras when using Codec C90.

Locate the Extra Camera and Power connectors.

- Power. The first camera in the chain is powered up from the codec by the VISCA camera control cable. Additional cameras must use the 12V DC Power in.
- Extra camera cable. The daisy chained cameras are connected by using the VISCA Extra Camera cable (maximum length 20 m / 65.6 ft) between the Extra Camera and Codec Control sockets

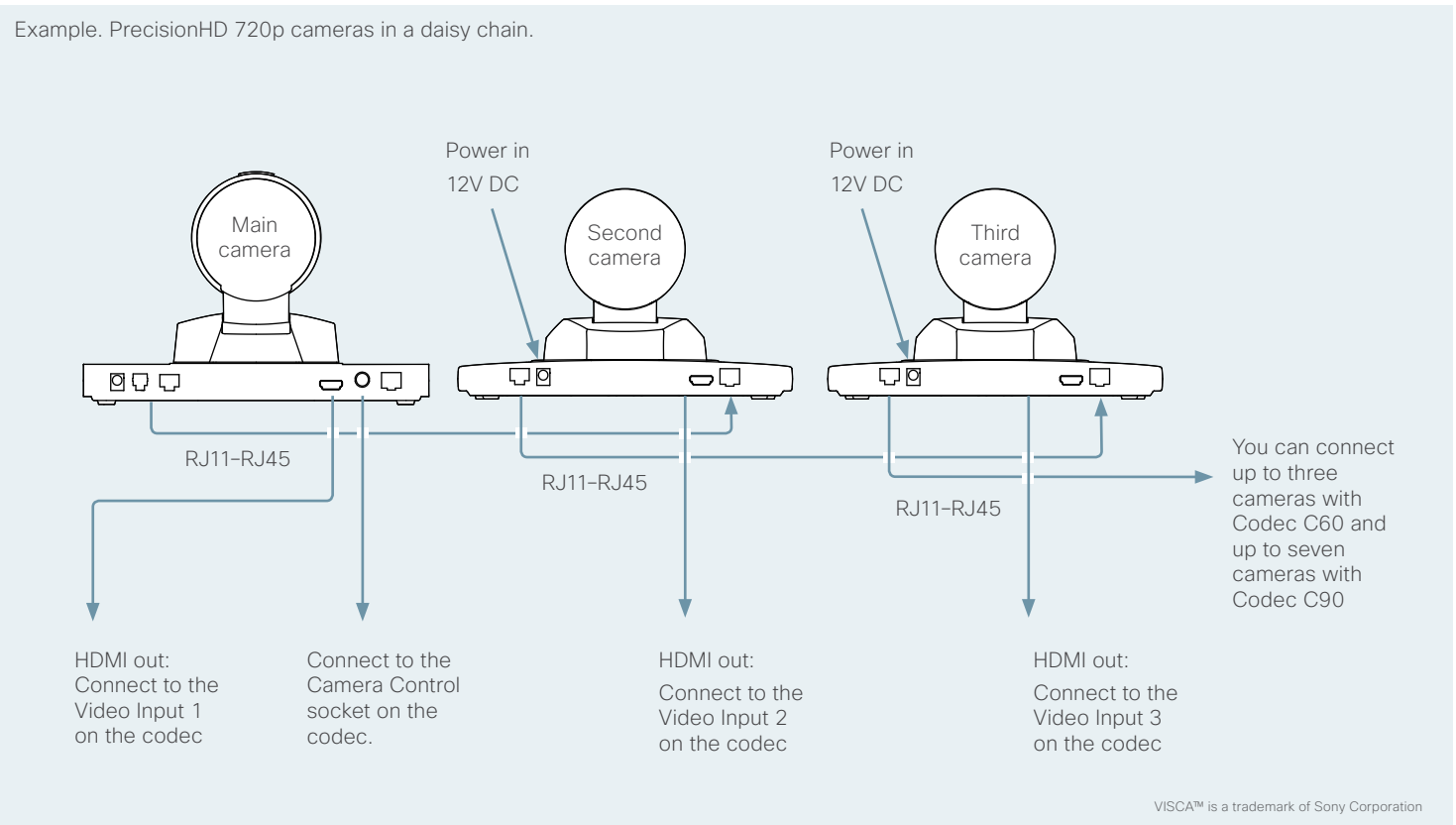

Daisy chaining of the PrecisionHD 1080p4x

NOTE: The PrecisionHD 1080p4x can only be used as the last camera in a daisy chain. Here depicted as the third camera.

A single daisy chain can have:

- Three cameras when using Codec C60
- Seven cameras when using Codec C90.

Locate the Extra Camera and Power connectors.

- Power. The first camera in the chain is powered up from the codec by the VISCA camera control cable. Additional cameras must use the 12V DC Power in.
- Extra camera cable. The daisy chained cameras are connected by using the VISCA Extra Camera cable (maximum length 20 m / 65.6 ft) between the Extra Camera and Codec Control sockets

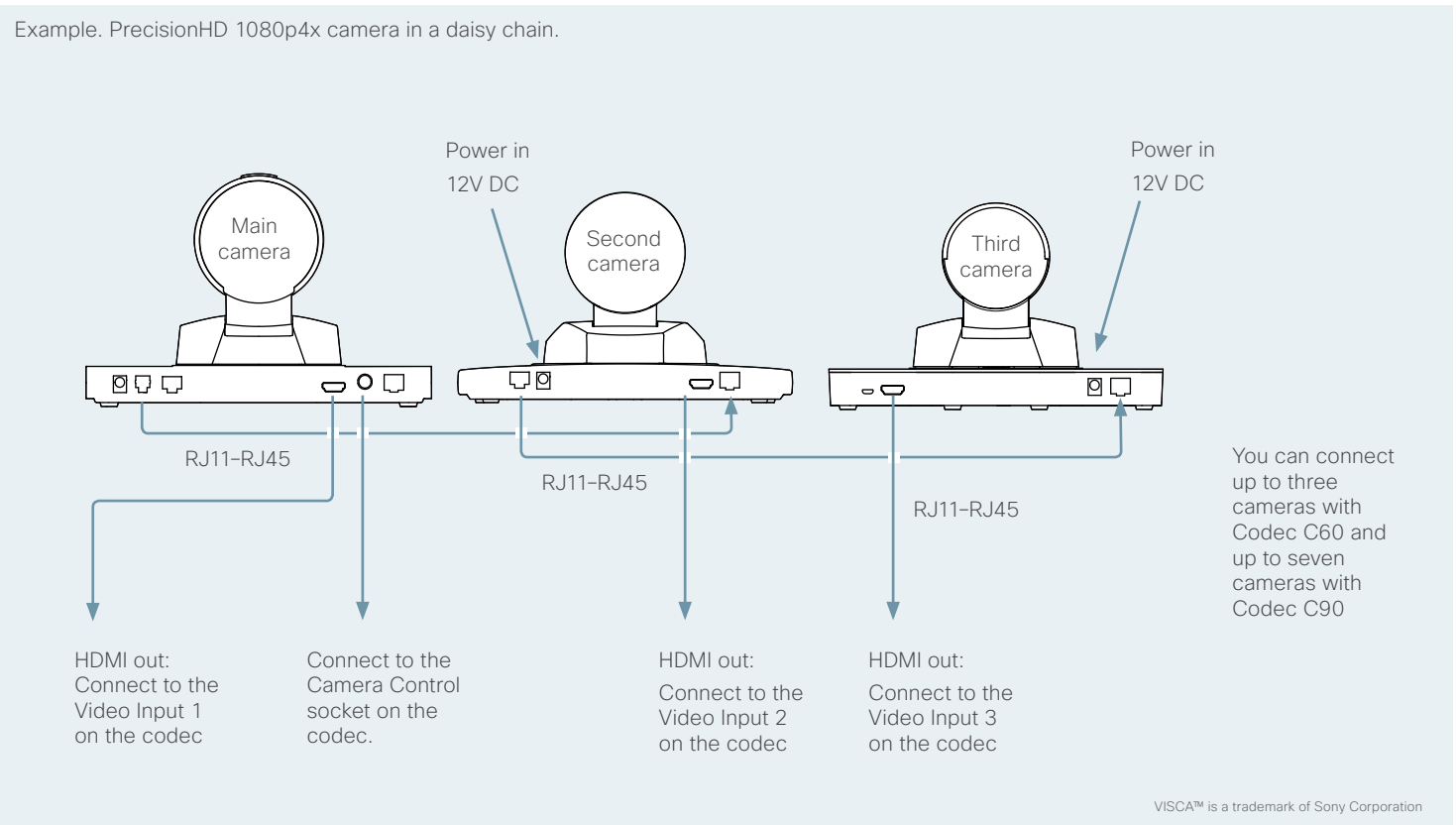

Chapter 6

Appendices



PrecisionHD
1080p12x



PrecisionHD
1080p4x



PrecisionHD
1080p4xS2



PrecisionHD
720p

Controlling cameras using the VISCA™ protocol

The information in this chapter applies to:

- PrecisionHD Camera 1080p12x
- PrecisionHD Camera 1080p4x
- PrecisionHD Camera 1080p4xS2

NOTE: Some of the VISCA™ commands do not apply to the PrecisionHD 1080p4x/4xS2 cameras. You will find these commands marked with a * (star) throughout this section.

INFORMATION: The VISCA™ commands for PrecisionHD 720p camera is found in the MXP Reference User Guide for System Integrators. Go to: ► <http://www.cisco.com/go/telepresence/docs>

The camera uses an RS-232 control interface that resembles the Sony VISCA™ protocol. The VISCA protocol (VIdeo System Control Architecture) is a Sony protocol for synchronized control of multiple video peripherals.

VISCA™ is a trademark of Sony Corporation

RS-232 Parameters

At startup, the communication parameters for the RS-232 interface must be set to:

- 9600 bits per second
- 8 data bits
- No parity
- 1 stop bit
- No hardware flow control
- No software flow control

All the RS-232 parameters except speed are fixed and not user configurable. The speed may be changed by issuing the **Speed command** defined on the following pages.

All control bytes are pure binary information, i.e. the control bytes are not ASCII-encoded.

RS-232 Commands and inquiries

A list of all the available commands and inquiries together with the result and comments are found in the table on the following pages.

The VISCA™/RS-232 control protocol

The codec is using the Sony Visa protocol to control the cameras.

Interfacing the camera

When interfacing to the camera the codec uses an RS-232 control interface that resembles the Sony VISCA™ protocol.

Supported cameras

The following Cisco PrecisionHD cameras are supported:

- PrecisionHD 1080p12x
- PrecisionHD 1080p4x
- PrecisionHD 1080p4xS2

Currently there is support for detection of the following third party cameras:

- Sony HD1
- Sony HD7

VISCA message format

A particular command is recognized by the message information after the address byte.

Message Format

Commands are initiated from the host (i.e. the codec or any other external controller) to the camera.

After a camera has been issued a command, the camera will generate a response.

Commands and responses (messages) have the following format:

- Address byte (1)
- Message bytes (1..14)
- Terminator byte (1)

See the illustration for details.

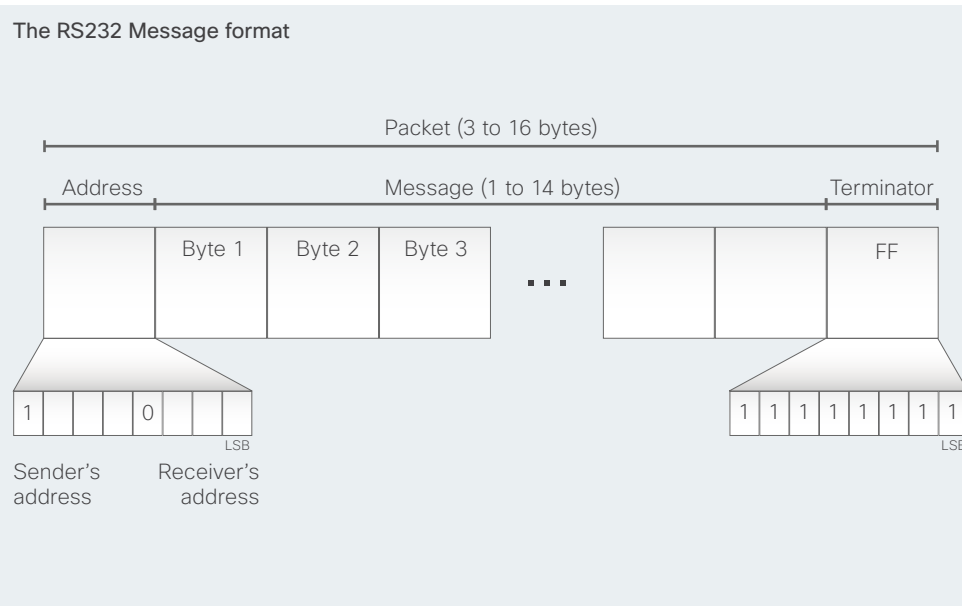

The minimum length of any command or response is 3 bytes:

1. **Address byte (1):** Let us assume there is one host, i.e. the codec (the host is the unit controlling the camera). The host has address 0. The four least significant bits of the address byte contain the address of the receiver. In the case of a broadcast message, the receiver address must be set to 8. When we are operating a single camera, the address is 1. Hence, address bytes in messages from the host are 0x81, and messages from the camera to the host are 0x90 (the protocol allows for up to 7 cameras).
2. **Message bytes (1..14):** Any number of bytes containing the actual message information. Bytes may have any value in the range 0...254. The value 255 (i.e. hexadecimal FF) is reserved for the terminating byte.
3. **Terminator byte (1):** All messages must be terminated with a byte containing all 1's, i.e. decimal 255 (or hexadecimal FF).

Command and response exchange

When the camera receives a command, it responds with either:

- **Completion message: 90-5Y-FF**
Returned by camera when execution of commands and inquiries are completed.
- **Error packets: 90-6Y-..-FF**
Returned by camera instead of a completion message when command or inquiry failed to be executed.
- **General error messages, unless otherwise specified:**
 - 90-6Y-01-FF Message length error (>14 bytes)
 - 90-6Y-02-FF Syntax error
 - 90-6Y-03-FF Command buffer full
 - 90-6Y-04-FF Command cancelled
 - 90-6Y-05-FF No socket (to be cancelled)
 - 90-6Y-41-FF Command not executable
- **Y = socket number**
A camera may contain two buffers so that two commands, including the command being executed, can be received.
NOTE: The PrecisionHD 1080p camera supports a single socket only. Consequently, the Y always assumes the value **Y=0**.

Exceptions to these rules:

- An Initialize message will respond as indicated in the Table of Commands (this message is in fact a broadcast message, and any unit other than the host receiving the broadcast message must pass it on).
- Do not route commands or replies that are longer than 16 bytes through Sony cameras. The easiest way to avoid this is to put the Cisco cameras first in the chain. Commands and replies that are longer than 16 bytes are clearly marked below.

The VISCA™/RS-232 control protocol, cont...

NOTE: Some VISCA™ commands do not apply to the PrecisionHD 1080p4x/4xS2 cameras.

Network and interface commands

Command set	Command packet	Comments
IF_Clear	8x 01 00 01 ff	Clear command buffer. Stop any current operation in progress.
Address_Set	8x 30 0p ff	p = address for this device. If x=8 (broadcast), increase p with 1 before sending to chain.
Command_Cancel *	8x 2p ff	p = Socket ID. PrecisionHD 1080p 12x does not support multiple sockets. Commands will always run to completion. Don't use it.

Push messages

Messages sent from camera to controller.

Command set	Command packet	Reply and comments
Network_Change	y0 38 ff	This indicates that cameras have been added to or removed from the chain. It is recommended to wait 9 seconds after receiving this message before doing a full reconfigure.
IR_Push	y0 07 7d 02 gg hh ff	If IR mode is on, IR codes received by the camera will be sent to the controller. gg = IR ID hh = keycode

Camera commands

Command	Command Packet	Comments
Power_On	8x 01 04 00 02 ff	Power control. This command stores the zoom and focus value and reset these motors. Used for PrecisionHD 720p if the camera was on for a long time. Puts the PrecisionHD 1080p camera in standby position.
Power_Off	8x 01 04 00 03 ff	
Video_Format	8x 01 35 0p 0q 0r ff	Selects video format. p = reserved q = video mode. See the video format table: ► Video mode selection . r = Used in PrecisionHD 720p camera. Can be recycled.
WB_Auto	8x 01 04 35 00 ff	WB: White Balance
WB_Table_Manual	8x 01 04 35 06 ff	
WB_Table_Direct	8x 01 04 75 0p 0q 0r 0s ff	Used if WBmode = Table manual pqrs = wb table.
AE_Auto	8x 01 04 39 00 ff	AE: Automatic Exposure.
AE_Manual	8x 01 04 39 03 ff	
Iris_Direct	8x 01 04 4B 0p 0q 0r 0s ff	Used if AE mode = Manual. pqrs: Iris position, range 0..50
Gain_Direct	8x 01 04 4c 0p 0q 0r 0s ff	Used if AE mode = Manual. pqrs: Gain position, values:12-21dB.
Backlight_On	8x 01 04 33 02 ff	BacklightCompensation mode
Backlight_Off	8x 01 04 33 03 ff	

* Do not apply to PrecisionHD 4x/4xS2 cameras

The VISCA™/RS-232 control protocol, cont...

NOTE: Some VISCA™ commands do not apply to the PrecisionHD 1080p4x/4xS2 cameras.

Camera commands, *continued...*

Command	Command Packet	Comments
Mirror_On	8x 01 04 61 02 ff	Sony calls this CAM_LR_Reverse. RR (FT/AT mirror command). The “xConfiguration Cameras Camera [1..n] Mirror: Auto” (supported by the Codec C-series) do not apply to the PrecisionHD 1080p 4x.
Mirror_Off	8x 01 04 61 03 ff	
Flip_On	8x 01 04 66 02 ff	Sony calls this CAM_ImgFlip. The “xConfiguration Cameras Camera [1..n] Flip: Auto” (supported by the Codec C-series) do not apply to the PrecisionHD 1080p 4x.
Flip_Off	8x 01 04 66 03 ff	
Gamma_Auto	8x 01 04 51 02 ff	Gamma mode. Default uses gamma table 4.
Gamma_Manual	8x 01 04 51 03 ff	
Gamma_Direct	8x 01 04 52 0p 0q 0r 0s ff	pqrs: Gamma table to use in manual mode. Range 0-7.
MM_Detect_On	8x 01 50 30 01 ff	Turn on the Motor Moved Detection (camera recalibrates if touched)
MM_Detect_Off	8x 01 50 30 00 ff	Turn off the Motor Moved Detection (camera does not recalibrate if touched)
Call_LED_On	8x 01 33 01 01 ff	Refers to orange LED on top of camera. Will always be off at startup.
Call_LED_Off	8x 01 33 01 00 ff	
Call_LED_Blink	8x 01 33 01 02 ff	
Power_LED_On	8x 01 33 02 01 ff	Green power LED. If switched to off and stored to startup profile, it will always be off.
Power_LED_Off	8x 01 33 02 00 ff	

Command	Command Packet	Comments
IR_Output_On	8x 01 06 08 02 ff	See IR push message.
IR_Output_Off	8x 01 06 08 03 ff	
IR_CameraControl_On	8x 01 06 09 02 ff	Lets up/down/left/right/zoom+/- on the IR remote control the camera directly. Those keycodes will be sent to the controller if IR Output is on.
IR_CameraControl_Off	8x 01 06 09 03 ff	

PTZF - movement commands

Command	Command Packet	Comments
Zoom_Stop	8x 01 04 07 00 ff	
Zoom_Tele	8x 01 04 07 2p ff	p = speed parameter, a (low) to b (high)
Zoom_Wide	8x 01 04 07 3p ff	
Zoom_Direct	8x 01 04 47 0p 0q 0r 0s ff	pqrs: zoom position
ZoomFocus_Direct	8x 01 04 47 0p 0q 0r 0s 0t 0u 0v 0w ff	pqrs: zoom position tuvw: focus position
Focus_Stop	8x 01 04 08 00 ff	
Focus_Far	8x 01 04 08 2p ff	p = speed parameter, a (low) to b (high)
Focus_Near	8x 01 04 08 3p ff	
Focus_Direct	8x 01 04 48 0p 0q 0r 0s ff	pqrs: focus position

* Do not apply to PrecisionHD 4x/4xS2 cameras

The VISCA™/RS-232 control protocol, cont...

NOTE: Some VISCA™ commands do not apply to the PrecisionHD 1080p4x/4xS2 cameras.

PTZF - movement commands, *continued...*

Command	Command Packet	Comments
Focus_Auto	8x 01 04 38 02 ff	Autofocus mode on/off. NOTE: If mode is auto, camera may disable autofocus when focus is ok. Autofocus will be turned back on when camera is moved using Zoom_Tele/Wide, PT_Up/Down/Left/Right. Ditto for IR_CameraControl movement.
Focus_Manual	8x 01 04 38 03 ff	
PT_Stop	8x 01 06 01 03 03 03 03 ff	
PT_Reset	8x 01 06 05 ff	Reset pan/tilt to center position. Will also re-synchronize motors.
PT_Up	8x 01 06 01 0p 0t 03 01 ff	p pan speed t: tilt speed
PT_Down	8x 01 06 01 0p 0t 03 02 ff	Right -> increment pan Left -> decrement pan
PT_Left	8x 01 06 01 0p 0t 01 03 ff	Up -> increment tilt Down -> decrement tilt
PT_Right	8x 01 06 01 0p 0t 02 03 ff	
PT_UpLeft	8x 01 06 01 0p 0t 01 01 ff	
PT_UpRight	8x 01 06 01 0p 0t 02 01 ff	
PT_DownLeft	8x 01 06 01 0p 0t 01 02 ff	
PT_DownRight	8x 01 06 01 0p 0t 02 02 ff	
PT_Direct	8x 01 06 02 0p 0t 0q 0r 0s 0u 0v 0w 0x 0y ff	p: max pan speed t: max tilt speed qrsu: pan position vwxy: tilt position Attempts to linearize movement.

Command	Command Packet	Comments
PTZF_Direct	8x 01 06 20 0p 0q 0r 0s 0t 0u 0v 0w 0x 0y 0z 0g 0h 0i 0j 0k ff	NOTE: Never route this message through Sony cameras. Sets all motors in one operation. pqrs: pan tuvw: tilt xyzg: zoom hijk: focus Attempts to linearize movement for pan and tilt.
PT_Limit_Set *	8x 01 06 07 00 0x 0p 0q 0r 0s 0t 0u 0v 0w ff	x=1: Up/Right x=0: Down/Left pqrs: Pan limit tuvx: Tilt limit. This command is valid only to next boot.
PT_Limit_Clear *	8x 01 06 07 01 0x [...] ff	x=1: Up/Right x=0: Down/Left Sony specifies lots of filler bytes after 0x. Ignore them.

* Do not apply to PrecisionHD 4x/4xS2 cameras

The VISCA™/RS-232 control protocol, cont...

NOTE: Some VISCA™ commands do not apply to the PrecisionHD 1080p4x/4xS2 cameras.

Inquiries

Command	Command Packet	Response
CAM_ID_Inq	8x 09 04 22 ff	Resp: 90 50 zz xx 00 yy ff Only zz, which identifies the camera, is relevant. zz = 0x50 for this camera.
CAM_SWID_Inq	8x 09 04 23 ff	Resp: y0 50 [1-125 bytes ASCII SWID] ff. Never route this message through Sony cameras.
CAM_HWID_Inq	8x 09 04 24 ff	The response is the Module Serial Number stored in EEPROM. The number is converted to ASCII : y0 50 [12 bytes ASCII HWID] ff.
Zoom_Pos_Inq	8x 09 04 47 ff	Resp: y0 50 0p 0q 0r 0s ff pqrs: zoom position
Focus_Pos_Inq	8x 09 04 48 ff	Resp: y0 50 0p 0q 0r 0s ff pqrs: focus position
Focus_Mode_Inq	8x 09 04 38 ff	Resp: y0 50 0p ff p=2: Auto, p=3: Manual
PanTilt_Pos_Inq	8x 09 06 12 ff	Resp: y0 50 0p 0q 0r 0s 0t 0u 0v 0w ff pqrs: pan position tuvw: tilt position
Power_Inq	8x 09 04 00 ff	Resp: y0 50 0p ff p=2: On, p=3: Off
WB_Mode_Inq	8x 09 04 35 ff	Resp: y0 50 0p ff p=0: Auto , p=6: Table manual
WB_Table_Inq	8x 09 04 75 ff	Resp: y0 50 0p 0q 0r 0s ff pqrs: Table used if table mode
AE_Mode_Inq	8x 09 04 39 ff	Resp: y0 50 0p ff p=0: Auto, p=3: Manual
Backlight_Mode_Inq	8x 09 04 33 ff	Resp: y0 50 0p ff p=2: On, p=3: Off
Mirror_Inq	8x 09 04 61 ff	Resp: y0 50 0p ff p=2: On, p=3: Off
Flip_Inq	8x 09 04 66 ff	Is video flipped or not? Resp: y0 50 0p ff p=2: On , p=3: Off

Command	Command Packet	Response
Gamma_Mode_Inq	8x 09 04 51 ff	Resp: y0 50 0p ff p=2: Auto, p=3: Manual
Gamma_Table_Inq	8x 09 04 52 ff	Resp: y0 50 0p 0q 0r 0s ff pqrs: Gamma table in use if manual mode.
Call_LED_Inq	8x 09 01 33 01 ff	Resp: y0 50 0p ff p=2: On, p=3: Off, p=4: Blink
Power_LED_Inq	8x 09 01 33 02 ff	Resp: y0 50 0p ff p=2: On, p=3: Off
Video_System_Inq	8x 09 06 23 ff	y0 50 0p 0q 0r 0s ff pqrs=video mode currently being output on the HDMI port. See chapter on DIP switches.
DIP_Switch_Inq *	8x 09 06 24 ff	y0 50 0p 0q 0r 0s ff pqrs contains the bit pattern of the DIP switch. See chapter on DIP switches.
IR_Output_Inq	8x 09 06 08 ff	Resp: y0 50 0p ff p=2: On, p=3: Off
ALS_RGain_Inq *	8x 09 50 50 ff	Ambient Light Sensor Resp: y0 50 0p 0q 0r 0s 0t 0u 0v 0w ff pqrstuv=32 bit unsigned integer, relative gain value. The integration time is a constant set in the camera SW.
ALS_BGain_Inq *	8x 09 50 51 ff	
ALS_GGain_Inq *	8x 09 50 52 ff	
ALS_WGain_Inq *	8x 09 50 53 ff	
Up side down_Inq *	8x 09 50 70 ff	Resp: y0 50 0p ff p=0: Camera is upright. p=1: Camera is upside down.

* Do not apply to PrecisionHD 4x/4xS2 cameras

The VISCA™/RS-232 control protocol, cont...

NOTE: Some VISCA™ commands do not apply to the PrecisionHD 1080p4x/4xS2 cameras.

Software upload commands

The CRC algorithm used, is the same as in the XModem protocol. CRC for the last data packet is only calculated for the actual data bytes in the packet. Pad last packet with 0x00 so that the data section is 256 bytes long. The PacketID counter starts at 0.

Command set	Command packet	Comments
SW start	8x 01 50 a2 0p 0q 0r 0s 0t 0u 0v 0w ff	pqrstuvw = size, pq=LSB Returns y050ff if ok. Fatal errors: Returns y06006ff if upload already in progress. Returns y06007ff if unable to access the flash.
SW end	8x 01 50 a1 ff	Sent after last SW packet, instructs camera to verify new application. Command may take up to 30 seconds to complete. Returns y050ff if ok. Issue a camera reboot to activate new software. Returns y06008ff if verification of sw failed.
SW abort	8x 01 50 a3 ff	Abort sw upload in progress
SW packet	8x a0 pp qq rr ss [256 bytes data]	ppqq = 16 bit packet id, pp=LSB rrss = 16 bit CRC, rr=LSB Returns y0 50 ff if packet ok. -> send next one. Returns y0 60 09 ff if crc error -> retransmit packet. Returns y0 60 0a ff if id error -> retransmit packet Fatal errors: y0 60 0b ff not in upload mode y0 60 0c ff error writing data to flash NOTE: Entire message after 8x a0... is raw data, so it may contain 0xff. Header is kept as short as possible. Never route this message through Sony cameras.

Debug commands for Cisco cameras

NOTE: Never route these messages through Sony cameras. They are provided for debugging on the PrecisionHD cameras only, and do not conform to the Visca length requirements.

Command set	Command packet	Comments
CAM_PingPong_Reset *	8x ae ff	Reset ping ctr to 0.
CAM_Ping *	8x af 0p 0q 0r 0s [256 bytes data] ff	pqrs = Pingval. Camera will respond with OK if correct pingval received. Increase ctr with 1 for next packet. Data section will be dumped to stdout if it fails.
CAM_Stdin *	8x a4 [0-256 bytes stdin] 00 ff	Send command to the command interpreter.
CAM_Debug_Mode *	8x 01 39 0q ff	q=0: Debug mode off. q=1: Debug mode on. Camera will send stdout as visca messages in the following format: y0 50 [0-256 bytes stdout] 00 ff

Other commands

Command set	Command packet	Comments
CAM_Boot	8x 01 42 ff	Reboot the camera. This will also reset serial speed to 9600.
CAM_Speed	8x 01 34 0p ff	p=0: Serial speed 9600. p=1: Serial speed 115200. Reply will be sent before the speed switch takes place. Please wait 20ms after ok before sending new commands.

* Do not apply to PrecisionHD 4x/4xS2 cameras

The VISCA™/RS-232 control protocol, cont...

NOTE: The information on this page applies to PrecisionHD Camera 1080p12x only.

Video mode selection

The DIP switch selection has priority over the selection made by the *CAM_Video_Format* command. If the DIP switch is set to auto, the *CAM_Video_Format* setting will be used. If both are set to auto, resolution will be controlled automatically by EDID.

DIP Switch settings

Switches are numbered 1 to 5. The VISCA column shows the value that must be used when using the *CAM_Video_Format* command.

NOTE: The DIP switches are only read by the SW at startup/ boot. So if the DIP switches are changed the camera must be rebooted.

If an undefined mode is selected, the output will default to auto.

DIP switch table

DIP Switch table for VISCA commands and video output formats							
1	2	3	4	5	VISCA	HDMI	HD-SDI
0	0	0	0	0	x	Auto*	
0	0	0	0	1	0x0000	1080p25	1080p25
0	0	0	1	0	0x0001	1080p30	1080p30
0	0	0	1	1	0x0002	1080p50	720p50
0	0	1	0	0	0x0003	1080p60	720p60
0	0	1	0	1	0x0004	720p25	720p25
0	0	1	1	0	0x0005	720p30	720p30
0	0	1	1	1	0x0006	720p50	720p50
0	1	0	0	0	0x0007	720p60	720p60
0	1	0	0	1	0x0009	SW control	

The table shows the different settings available for the HDMI and the HD-SDI outputs.

Auto: Camera negotiates format over HDMI. HD-SDI tracks HDMI and defaults to 1080p30 in absence of HDMI sync.

Software: Used when controlling cameras using the VISCA protocol.

PrecisionHD 1080p12x, from below

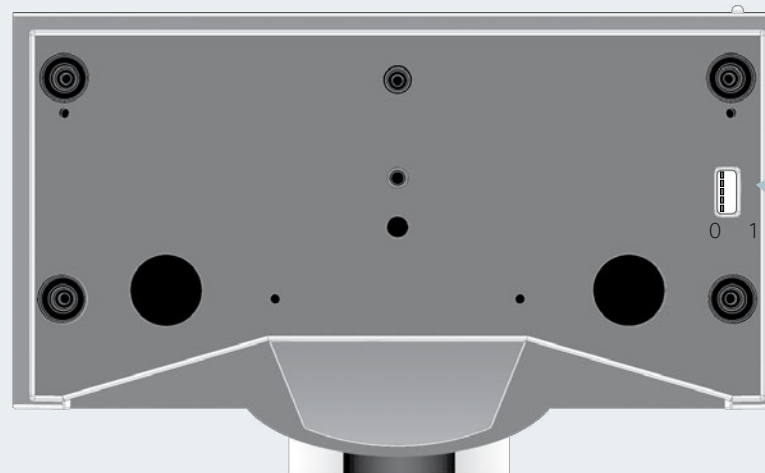

The DIP switches 1 to 5

Technical specifications

PrecisionHD Camera 1080p4x

Available with Quick Set C20

- 1080p30/720p60 True High Definition
- 4 x optical zoom
- HDMI output
- Mount upside down—(select option through VISCA™)
- Pan speed: 100°/s, range: -90° to +90°
- Tilt speed: 30°/s, range: -15° to +15°
- 43.5° vertical field of view
- 70° horizontal field of view
- Focus distance 0.3m-infinity
- 1920 x 1080 pixels progressive @ 30fps
- 1280 x 720 pixels progressive @ 60fps
- Automatic or manual focus, brightness, and white balance
- Far-end camera control
- Daisy-chain support (can only be in the end of a chain)
- Height (at max tilt): 151 mm/5.94"
- Width: 212 mm/8.35"
- Depth: 138 mm/5.43"
- Weight: 1.44 kg/3.17 lbs

PrecisionHD Camera 1080p4xS2

Available with SX20 Quick Set

- 1080p60 True High Definition
- 1/3" CMOS
- 4 x optical zoom
- HDMI output
- Mount upside down—(select option through VISCA™)
- Pan speed: 100°/s, range: -90° to +90°
- Tilt speed: 30°/s, range: -25° to +15°
- 43.5° vertical field of view
- 70° horizontal field of view
- Focus distance 0.3 m-infinity
- 1920 x 1080 pixels progressive @ 60fps
- Other formats supported:
 - 1920 x 1080 pixels progressive @ 30 fps
 - 1280 x 720 pixels progressive @ 60 fps
- Automatic or manual focus, brightness, and white balance
- Far-end camera control
- Daisy-chain support (can only be in the end of a chain)
- Height (At max tilt): H 150,5 mm/5.92"
- Width: 212 mm/8.35"
- Depth: 138,5 mm/5.45"
- Weight: 1.44 kg/3.17 lbs

PrecisionHD Camera 1080p4x*

NOTE: This is an interim version* of the 4x camera; available for a limited period of time.

- 1080p60 True High Definition
- 4 x optical zoom with smooth and quiet handling
- HDMI and HD-SDI outputs with ability to share picture simultaneously through both ports
- Mount upside down—camera orientation automatically detected and picture flipped
- 1/3" CMOS
- Pan speed: 100°/s, range: -90° to +90°
- Tilt speed: 40°/s, range: -25° to +15°
- 43.5° vertical field of view
- 72° horizontal field of view
- Focus distance 0.3 m-infinity
- 1920 x 1080 pixels progressive @ 30fps
- Other formats supported (configurable through Dip-switch):
 - 1920 x 1080@30 Hz
 - 1920 x 1080@25 Hz
 - 1280 x 720@30 Hz
 - 1280 x 720@25 Hz
- Automatic or manual focus, brightness, and white balance
- Far-end camera control
- Daisy-chain support (can only be in the end of a chain)
- Height (at max tilt): 172 mm/6.8"
- Width: 220 mm/8.7"
- Depth: 147 mm/5.8"
- Weight: 1.8 kg/3.97 lbs

* The early shipments of the Quick Set C20 came with an interim version of the PrecisionHD 1080p4x camera (the PrecisionHD 1080p4x* camera).

PrecisionHD Camera 1080p12x

- 1080p60 True High Definition
- 12 x optical zoom with smooth and quiet handling
- HDMI and HD-SDI outputs with ability to share picture simultaneously through both ports
- Mount upside down—camera orientation automatically detected and picture flipped
- 1/3" CMOS
- Pan speed: 100°/s, range: -90° to +90°
- Tilt speed: 40°/s, range: -25° to +15°
- 43.5° vertical field of view
- 72° horizontal field of view
- Focus distance 0.3m-infinity
- 1920 x 1080 pixels progressive @ 60fps
- Other formats supported (configurable through Dip-switch):
 - 1920 x 1080@60 Hz (HDMI only)
 - 1920 x 1080@50 Hz (HDMI only)
 - 1920 x 1080@30 Hz
 - 1920 x 1080@25 Hz
 - 1280 x 720@60 Hz
 - 1280 x 720@50 Hz
 - 1280 x 720@30 Hz
 - 1280 x 720@25 Hz
- Automatic or manual focus, brightness, and white balance
- Far-end camera control
- Daisy-chain support (VISCA™ protocol camera)
- Height (at max tilt): 172 mm/6.8"
- Width: 220 mm/8.7"
- Depth: 147 mm/5.8"
- Weight: 1.8 kg/3.95 lbs

PrecisionHD Camera 720p

- 720p30 High Definition
- 7 x optical zoom with fast and smooth video handling
- 1/3" CMOS
- Pan range: -90° to +90°
- Tilt range: -20° to +10°
- 42° vertical field of view, 72° total vertical field of view
- 70° horizontal field of view, 250° total horizontal field of view
- Focus distance 0.3m-infinity
- 1280 x 720 pixels progressive @ 30fps
- Automatic or manual focus, brightness, and white balance
- Far-end camera control
- Daisy-chain support (VISCA™ protocol camera)
- 15 near and far-end camera presets
- Voice-activated camera positioning
- In-call LED light display
- Power indicator
- Auto iris sensor
- Height (at max tilt): 167 mm/6.6"
- Width: 222 mm/8.8"
- Depth: 145 mm/5.7"
- Weight: 1.7 kg/3.75 lbs



On our web site you will find an overview of the worldwide Cisco contacts.

Go to: <http://www.cisco.com/web/siteassets/contacts>

Corporate Headquarters
Cisco Systems, Inc.
170 West Tasman Dr.
San Jose, CA 95134 USA

THE SPECIFICATIONS AND INFORMATION REGARDING THE PRODUCTS IN THIS MANUAL ARE SUBJECT TO CHANGE WITHOUT NOTICE. ALL STATEMENTS, INFORMATION, AND RECOMMENDATIONS IN THIS MANUAL ARE BELIEVED TO BE ACCURATE BUT ARE PRESENTED WITHOUT WARRANTY OF ANY KIND, EXPRESS OR IMPLIED. USERS MUST TAKE FULL RESPONSIBILITY FOR THEIR APPLICATION OF ANY PRODUCTS.

THE SOFTWARE LICENSE AND LIMITED WARRANTY FOR THE ACCOMPANYING PRODUCT ARE SET FORTH IN THE INFORMATION PACKET THAT SHIPPED WITH THE PRODUCT AND ARE INCORPORATED HEREIN BY THIS REFERENCE. IF YOU ARE UNABLE TO LOCATE THE SOFTWARE LICENSE OR LIMITED WARRANTY, CONTACT YOUR CISCO REPRESENTATIVE FOR A COPY.

The Cisco implementation of TCP header compression is an adaptation of a program developed by the University of California, Berkeley (UCB) as part of UCB's public domain version of the UNIX operating system. All rights reserved. Copyright © 1981, Regents of the University of California.

NOTWITHSTANDING ANY OTHER WARRANTY HEREIN, ALL DOCUMENT FILES AND SOFTWARE OF THESE SUPPLIERS ARE PROVIDED "AS IS" WITH ALL FAULTS. CISCO AND THE ABOVE-NAMED SUPPLIERS DISCLAIM ALL WARRANTIES, EXPRESSED OR IMPLIED, INCLUDING, WITHOUT LIMITATION, THOSE OF MERCHANTABILITY, FITNESS FOR A PARTICULAR PURPOSE AND NONINFRINGEMENT OR ARISING FROM A COURSE OF DEALING, USAGE, OR TRADE PRACTICE.

IN NO EVENT SHALL CISCO OR ITS SUPPLIERS BE LIABLE FOR ANY INDIRECT, SPECIAL, CONSEQUENTIAL, OR INCIDENTAL DAMAGES, INCLUDING, WITHOUT LIMITATION, LOST PROFITS OR LOSS OR DAMAGE TO DATA ARISING OUT OF THE USE OR INABILITY TO USE THIS MANUAL, EVEN IF CISCO OR ITS SUPPLIERS HAVE BEEN ADVISED OF THE POSSIBILITY OF SUCH DAMAGES.

Cisco and the Cisco Logo are trademarks of Cisco Systems, Inc. and/or its affiliates in the U.S. and other countries. A listing of Cisco's trademarks can be found at www.cisco.com/go/trademarks. Third party trademarks mentioned are the property of their respective owners. The use of the word partner does not imply a partnership relationship between Cisco and any other company. (1005R)

Any Internet Protocol (IP) addresses and phone numbers used in this document are not intended to be actual addresses and phone numbers. Any examples, command display output, network topology diagrams, and other figures included in the document are shown for illustrative purposes only. Any use of actual IP addresses or phone numbers in illustrative content is unintentional and coincidental.

TANDBERG is now a part of Cisco. TANDBERG® is a registered trademark belonging to Tandberg ASA.