

# Operations Manual



 **HUMMINBIRD**  
**LCR 3D**

## TRANSDUCER MOUNTING PROCEDURE

Humminbird's high-speed transducer is supplied with your LCR. This transducer has been designed to give good high speed readings on most all boat designs, including aluminum.

Please carefully consider the following before installing your transducer.

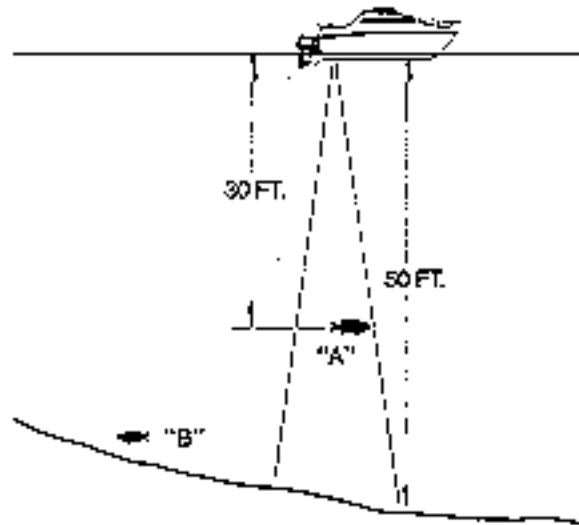
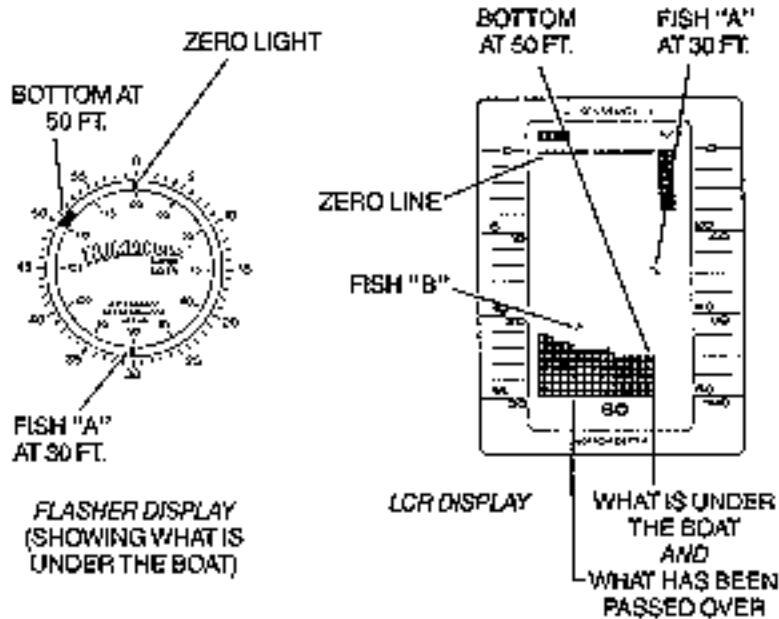

FIGURE 1

## TRANSDUCER MOUNTING OPTIONS

- A. Transom Mount- The Humminbird high speed transducer allows the transducer element to be mounted below the bottom of the boat hull keeping the transducer out of turbulent water and insuring good high speed operation. The transducer will absorb the blow of any obstruction

by rotating up out of the metal spring bracket without harming the transducer, or your boat. The transducer can be re-engaged by simply rotating the transducer down and snapping it back in place. (See Figure A)

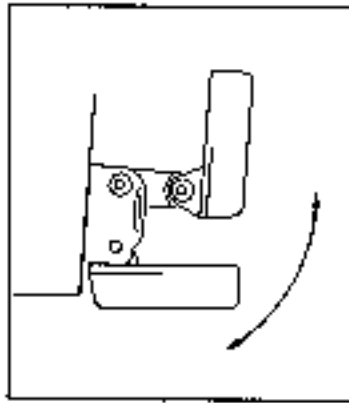

Figure A

- B. Inside Hull Mount- The high speed transducer can be mounted inside the hull (without pivot assembly) using the proper two-part epoxy, such as Humminbird's epoxy kit. Even though there is some loss of signal in shooting through the hull, your LCR will perform well with this type of installation. You cannot shoot through the hull of an aluminum boat.
- C. Trolling motor Mount- This type of transducer is not supplied with your LCR. It is designed to mount on the foot of a trolling motor. You may exchange your un-used high speed transducer for a trolling motor transducer. Call the Humminbird Customer Service Department.
- D. Bronz Thru-Hull Mount- This transducer is not supplied with your LCR but for an additional cost you may exchange your un-used high speed transducer for a bronz thru-hull. The bronz thru-hull transducer has a threaded stem which installs through a hole drilled in the boat hull, leaving the housing exposed under the boat. This type of installation must be used for many boats with in-board engines, because there is no suitable location on the transom away from the noise and turbulence created by the prop. A bronz thru-hull transducer should be installed by qualified personnel only.  
The LCR will operate well at high speeds with a properly mounted transducer. Remember, a transducer will not work transmitting through air or through air bubbles.

## 1. TRANSOM MOUNTING PROCEDURE

### Step 1.

**MOUNTING LOCATION-** It is important that the transducer be mounted on the transom where water flow is in constant contact with the transducer. You may wish to observe the rear of the boat while it is moving through the water to determine the best mounting location.

### Step 2.

**BRACKET INSTALLATION (Aluminum Boats)-** To install the metal bracket on an aluminum boat locate the template on the transom between rows of rivets, or ribs that are on the bottom of the boat. Align the template so that the bottom corner of the template nearest the center of the transom is on the bottom edge of the transom.

Figure B

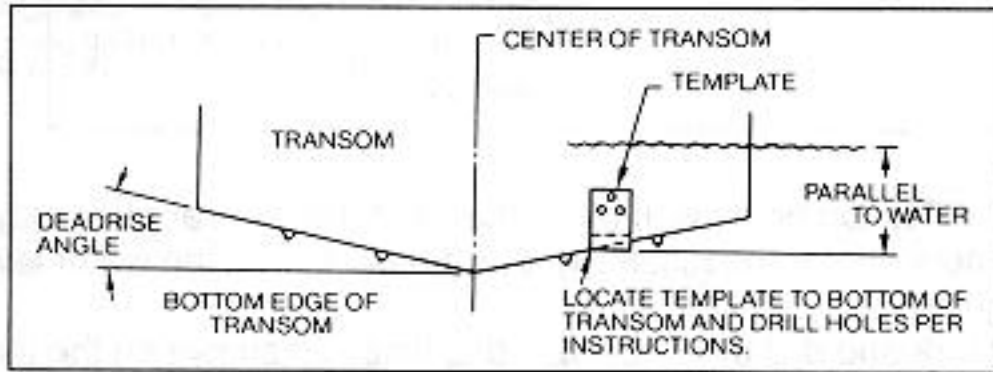

Once the location is determined mark and drill three 7/64" dia.. holes noted on the template. Attach the metal bracket using three #10 self threading screws supplied. Be sure to align holes in the center of the Bracket slots. On some aluminum boats it may be necessary to use a wood back-up plate. It is important to use a silicone sealant between the screwhead and bracket in order to prevent leaking. (See Figure C)

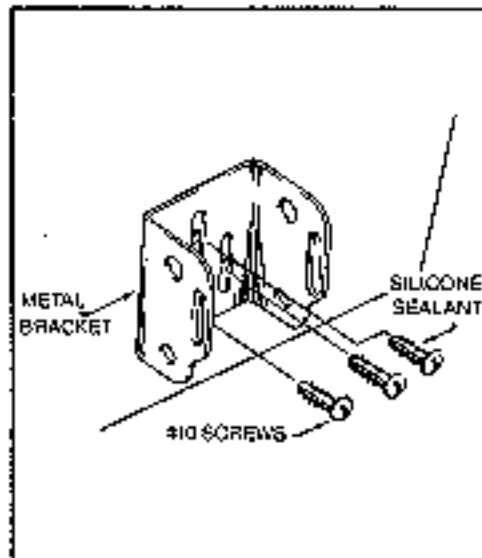
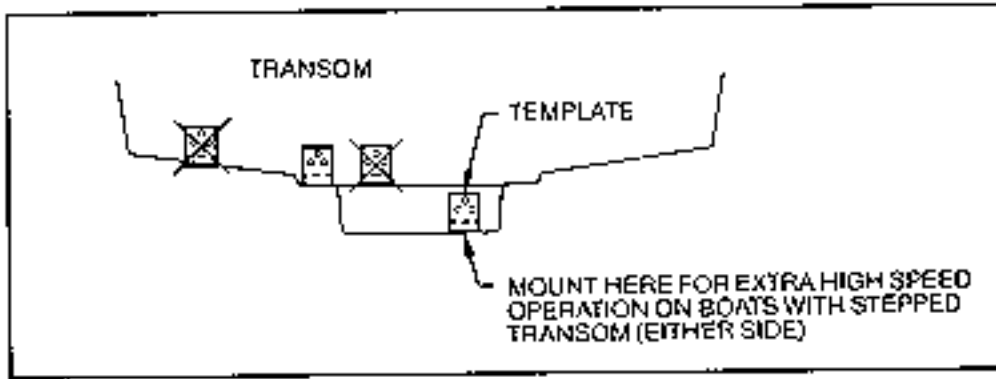

Figure C

Step 2.  
BRACKET INSTALLATION (Fiberglass Boats)- If your boat has a stepped transom located below and under the main transom, the compact transducer design allows mounting in this area. This mounting location is recommended for good reading at very high speeds. (See Figure D)

To install the metal bracket on a fiberglass boat, locate the template on the transom in the same manner as for an aluminum boat. (See Figure C)

Figure D



NOTE: On boats with more than 15 degree deadrise angle it may be necessary to mount the transducer slightly off parallel with the water level. (See Figure E)

Mark and drill the three 9/64" dia. holes as shown on the template. Attach the metal bracket using the three #10 self threading screws supplied. Be sure to align the holes so that they are centered vertically in the three slots found in the bracket. It is important to use a silicone sealant between the screwhead and bracket in order to prevent leaking.

Figure E

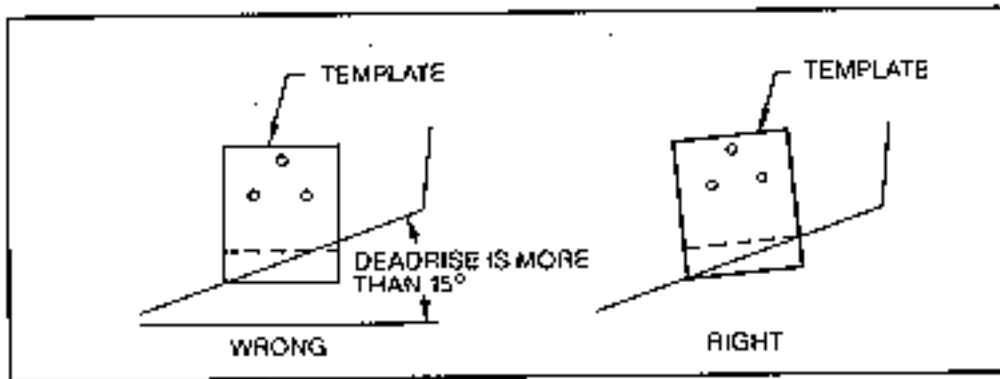

Step 3.

TRANSDUCER PIVOT ASSEMBLY- Assemble the pivot to the transducer main body using the two 1/4"x5/8" allen head screws, two 3/8" tooth washers and two, 1/4" square nuts. Make sure the tooth washers are sandwiched between the transducer main body and the pivot. The square nuts are trapped inside the pivot and will not rotate as the allen head screws are tightened. HOWEVER, DO NOT TIGHTEN AT THIS POINT. (See Figure F)

**CAUTION: DO NOT APPLY LOCTITE® OR SIMILAR LOCKING COMPOUNDS BECAUSE THEY WILL ATTACK THE PLASTIC.**

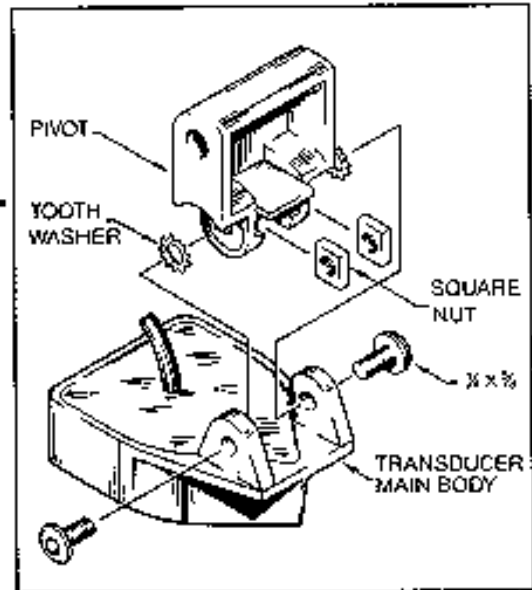

Figure F

Step 4

TRANSDUCER ASSEMBLY- Insert the transducer assembly into the metal bracket from the bottom. Push up until the holes in the plastic pivot align with the uppermost holes in the bracket. Slide the O-ring on to the headed pin and insert it through the two parts. Assemble by screwing the 1/4"x3/8" allen head screw into the end of the pin and tighten. (See Figure G)

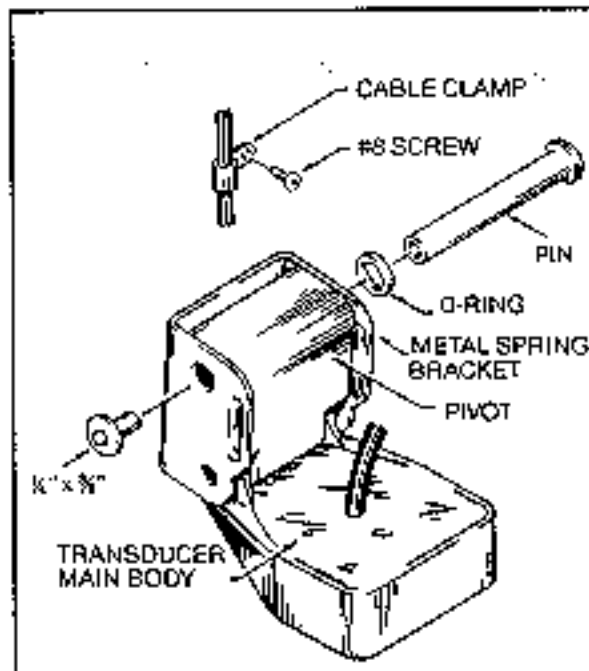

Figure G

Step 5

ANGLE ALLIGHMENT- Set the transducer angle so that it is parallel with the bottom of the boat hull. Once proper alignment is achieved, tighten the two allen head screws using the 5/32" allen

wrench provided. The screws are visible through the access holes on each side of the metal bracket. Check to make sure the transducer main body is rigidly fastened to the pivot. (See Figure H)

Figure H

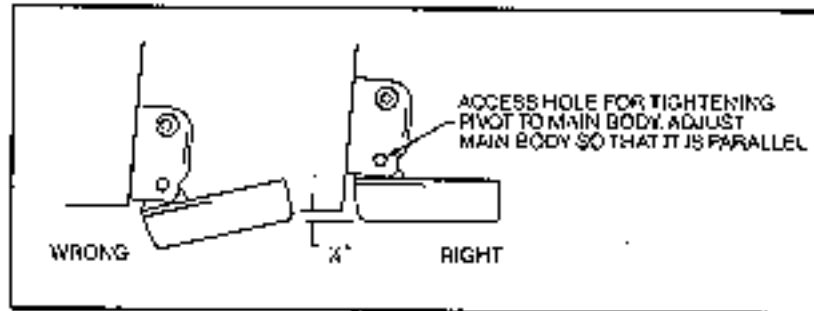

#### Step 6

**CHECK POSITION OF TRANSDUCER-** At this point, check to see that the bottom of the transducer is a minimum of 1/4" below the bottom of the transom. (However, as noted in STEP 2, the top of the transducer cannot fall below the bottom of the transom). If it is not, remove the transducer assembly from the metal bracket by removing the pin installed during STEP 3. Loosen the metal bracket mounting screws, re-position the bracket utilizing its slotted holes, tighten and re-assemble. It may be necessary to replace the silicone sealant after this adjustment is made.

**NOTE:** It may be necessary to make several high speed runs to adjust transducer either UP/DOWN or to re-adjust the angle to achieve optimum results.

#### Step 7

**CABLE CLAMPS-** Install cable clamps as necessary by drilling a 1/8" dia. hole for the # 8 screw supplied.

## 2. INSIDE HULL MOUNTING PROCEDURE

**Warning:** In order to achieve proper results with this type installation, it is important that the transducer be mounted by someone familiar with the use of two part epoxy adhesives. For this reason, Techsonic Industries, Inc. will not be responsible for any damage due to the mounting of your transducer in this manner.

**NOTE:** An Epoxy Kit (Part N. EPK) is available from Humminbird. This Epoxy Kit has been formulated for Inside Hull Transducer Installation.

1. Select as flat an area as possible near the aft end and center of boat where the hull is thin and not double. If the bottom has a runner down the center of boat, select an area to one side of the runner, but as close to the runner as possible.
2. Clean the inside of the boat with lacquer thinner in the area transducer is to be mounted. Outside of boat in this area should also be cleaned. (Not with lacquer thinner).
3. Put approximately one inch of water in the bottom of the boat.
4. Put transducer in the water. The bottom of the transducer should be in a flat area and should be in good contact with the bottom of the boat.
5. Operate the LCR with the boat operating at high speed. The transducer may have to be moved in order to find an area where satisfactory operation is observed.
6. When an area is found that produces satisfactory operation, mark the location of the transducer.

7. Remove the water and transducer and clean the marked area and the bottom of the transducer thoroughly.
8. Using the Humminbird Epoxy Kit or equivalent, mix an ample amount of epoxy without causing it to bubble and pour it in the area the transducer is to be mounted. The puddle should be larger than the bottom of the transducer.
9. Coat the bottom of the transducer with epoxy, then put it in the center of the puddle and push down on the transducer while moving it around in a circular motion. This forces out any air bubbles that may be trapped between the bottom of the transducer and the hull of the boat.
10. Let epoxy cure then the transducer is ready to operate. No water is now required in the bottom of the boat and gas and oil that is spilled inside of the boat will not degrade performance as it will if the transducer is placed only in water.  
CAUTION: Do not use the silicone seal or any soft adhesive to bond the transducer to the hull. This will reduce the sensitivity of the unit.

### CAUTIONS

1. Occasionally the "eye" of your transducer may become dirty from storage or from contact with oils present in boats or marina environments. (Oil will cause the "eye" to lose the intimate contact with the water which is necessary for efficient operation.) The "eye" may be cleaned with liquid detergent.
2. Improper installation of the transducer can alter the efficiency and accuracy of the entire system.
3. If your boat or transducer is out of the water for a period of time, it may take a short period of time for the transducer to become thoroughly "wetted" when returned to the water. Also, re-entry may cause turbulence, which will create air bubbles in the "eye" of the transducer. The bubbles will disappear in a short time or can be removed by rubbing the transducer "eye" with your fingers while the transducer is in the water.
4. If your instrument should fail to function, be sure to check all the electrical connections before removing the transducer or calling a serviceman.
5. Inspect your transducer cable and make sure that it has not been cut or damaged to the point where it will affect the performance of the transducer. A slight nick or cut, exposing the outer cable, can be repaired by wrapping with electrical tape. A transducer can be damaged if the inner cable and outer cable are allowed to make contact. Such a problem can sometimes be corrected by properly splicing the coaxial cable. This should only be attempted by a qualified service technician.
6. If your LCR is not working properly and you suspect the problem might be in your transducer, we would recommend you borrow a unit from a friend and try it on your boat. If the symptoms are the same, you can almost be certain that the problem is in the transducer.

### INSTALLING THE LCR

The LCR should be mounted on a flat, solid surface for maximum stability. The low profile swivel mount has four holes drilled in the base. It is recommended that all four holes be used.

Position the swivel base and drill four ¼" diameter holes. Note: The LCR hole pattern is the same as for all Humminbird flasher units. Use hardware provided to mount this base to the boat.

Next place the gimbal bracket on the swivel base and attach with four small machine screws, provided.

Place the LCR in the gimbal mount and make certain the rubber washers provided are placed between the unit and the gimbal bracket. Important: Note which side of the gimbal faces forward. (Slots on gimbal bracket go towards rear). Also, rubber washer must be located between the unit and the gimbal bracket.



Install the mounting knobs and tighten snugly. The unit can now be swiveled and tilted to any desired position.

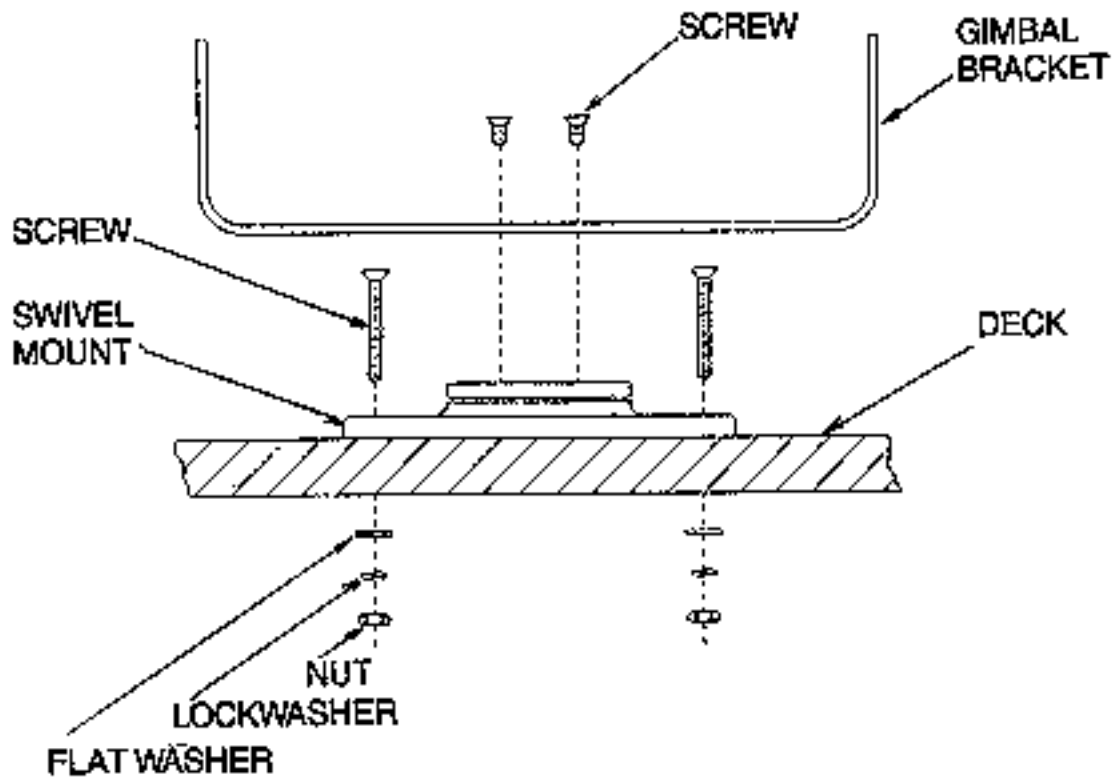

FIGURE 9

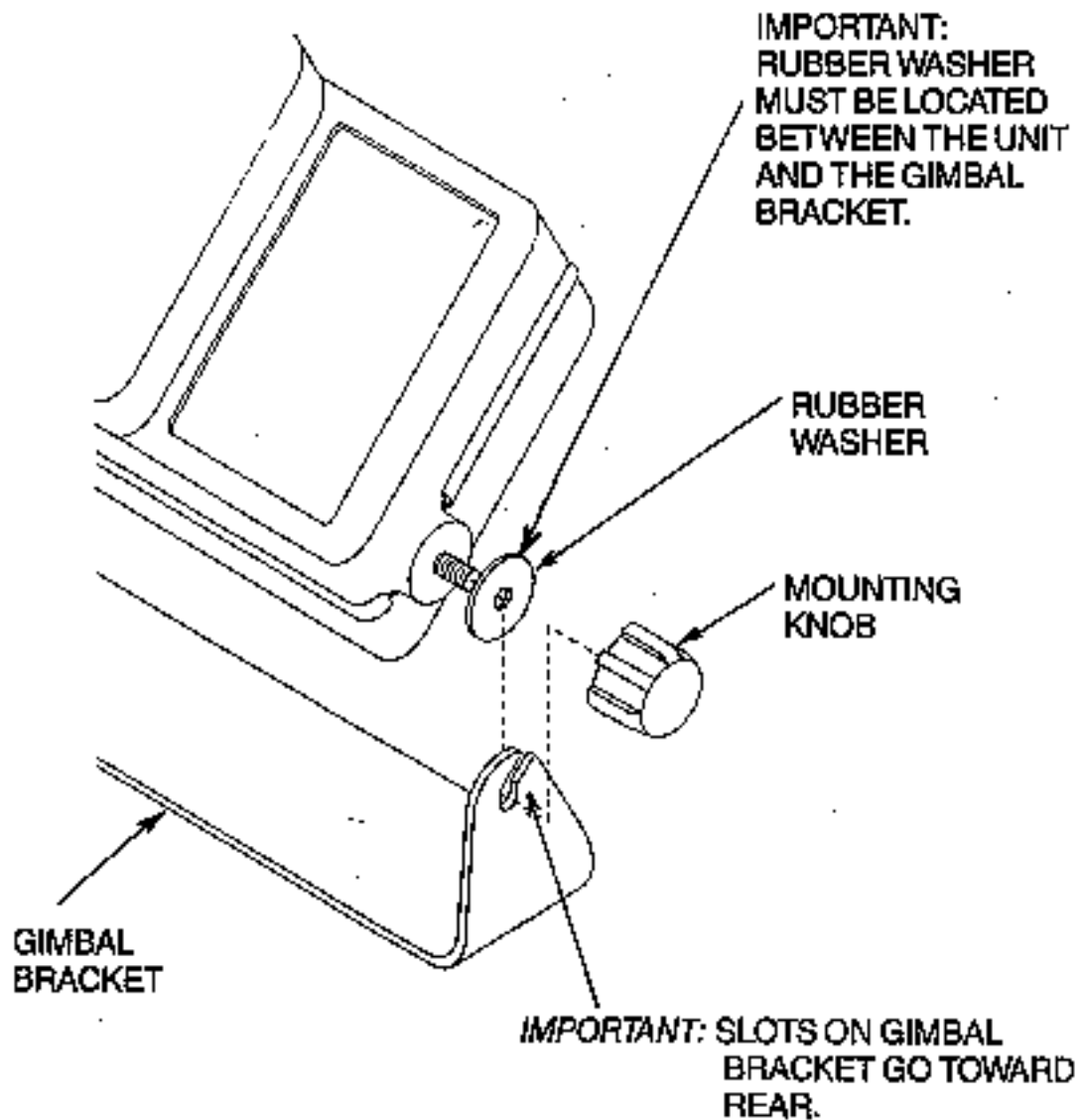

FIGURE 10

#### OTHER MOUNTING OPTIONS

1. The LCR gimbal bracket can also be mounted on the SM-4, quick disconnect swivel mount.
2. The LCR gimbal bracket can also be mounted directly to the dash without the swivel mount, however, this method is not recommended since the unit cannot be rotated.

#### INSTALLING THE CABLES

Your LCR comes equipped with Humminbird's new Angle-Lock power and transducer connectors. The power connector is identified with the letter P on the back of the plug.

It plugs into the outlet on the back of the unit marked "Power". The transducer connector is identified with the letter T and plugs into the outlet on the back of the unit marked "Transducer".  
Note: An adapter (AD-4) is available to allow use of an old waterproof (BNC) transducer with the LCR, but be sure that the transducer is a 16-degree. A 32-degree transducer cannot be used. A 1 1/8" hole must be drilled to pull through the transducer connector. After drilling the hole, pull the transducer connector up through the hole. If you are installing two units, both transducer connectors can be pulled through this 1 1/8" inch hole. Next, push the power cable wires down through the hole. A hole cover has been provided which will dress and hold the wires. Install the hole cover after determining the necessary wire length from the hole.  
The power cable has a red lead to the positive (+) post and the black lead to the negative (-) post. Install a 1 amp fuse between the red cable and positive post of your 12-volt battery.  
If a fuse panel is available, we recommend wiring the power cable into the fuse panel. Note: The LCR must be fused separately from any other accessory.  
Your Angle-Lock connectors can only be plugged in one way. Position the connector so the letter P or T can be read and the 90 degree bend is pointed downward. Push the connector in as far as it will go. Turn the positive locking ring as far as it will go clockwise until you feel it lock. Locking ring as far as it will go clockwise until you feel it lock. Your connector is now locked into place.  
Note: For easy access to the connectors, simply loosen the mounting knobs and tilt your LCR forward. The connectors are now in full view and easy to plug or unplug.

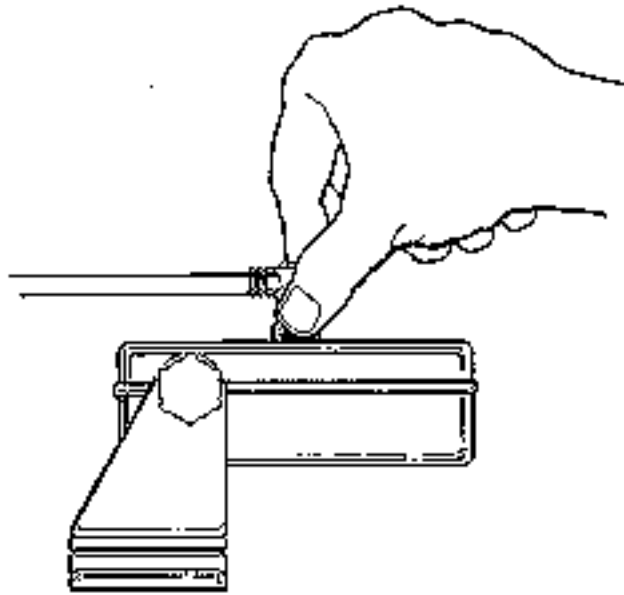

## BEFORE BEGINNING

There are two main components to a LCR 3D installation: The sensor, which you will install on the transom, and the LCR 3D unit, which you will mount with the supplied gimbal bracket. The sensor and LCR 3D unit communicate by means of a cable, and are powered by your boat's 12-volt DC battery.

The sensor and LCR 3D use the basic principles of sonar to reveal objects beneath the water's surface. The LCR 3D uses a four element sensor to transmit a "fan" like signal, which creates an elongated area of coverage - very wide side to side, but narrow front to rear. Once the signal strikes an object, it is immediately reflected back toward the boat and the sensor. The varying rate at which these signals return allows the LCR 3D unit to construct a very precise 3 dimensional view of the bottom on-screen.

The advanced technology incorporated into the LCR 3D identifies the size of a fish accurately regardless of where the fish is located in the area of coverage. This feature eliminates small fish close to the sensor or centered within a signal, from being displayed on screen as large fish. This also applies to large fish that might otherwise have been passed off as bait fish, or not seen at all when they were located on the edge of a signal.

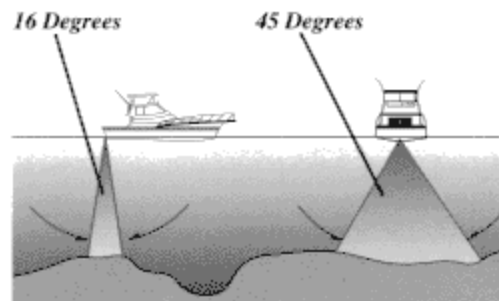

## HOW THE LCR 3D WORKS

The LCR 3D allows you to view this detailed sonar information in several different ways. The 3D view provides an easy to understand three-dimensional picture of the terrain beneath your boat. This view can be reversed in perspective to meet individual preferences. Also, ID turns on "strings" to attach fish to the bottom directly beneath them, to help you see their position relative to your boat. The 2D view will be familiar to users of other LCR products, and provides all the information of the 3D view compressed into a two-dimensional view. ID draws fish as one of three different size fish symbols, and "blacks in" in the area beneath the bottom for easier viewing.

Of course you can use zoom and bottom lock in either of these views to provide an even more detailed view.

And finally, the unique Quad-Beam® view displays sonar information from all four beams simultaneously. This is similar to using four different depthsounders at once with the sensors pointed in different directions.

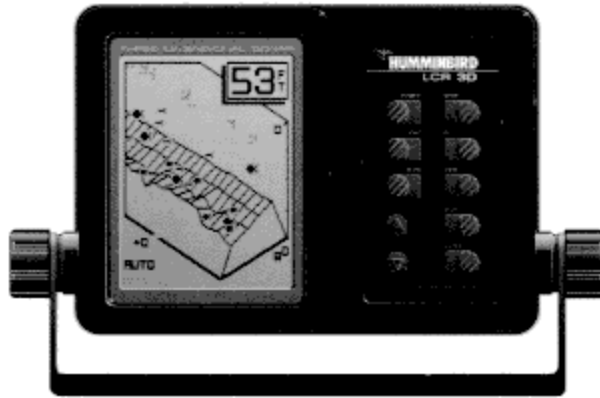

### THE HUMMINBIRD ADVANTAGE

The LCR 3D incorporates the best of available technologies, and offers advantages you won't find in other equipment. Three different view options, along with individual beam control, provide a wide array of viewing options.

The liquid crystal display (LCD) offers sharp viewing even in bright, direct sunlight, and offers lighting for night operation. Advanced LCD "super-twist" technology built into the LCR 3D offers a wider viewing angle and higher contrast than ordinary LCD screens. Contrast can also be manually adjusted for optimum viewing.

(Note that some polarized glasses can affect your view by causing a rainbow or prism to appear. If so, tilt the unit slightly, or manually adjust contrast as described in this manual.)

Though it includes sophisticated electronics, the LCR 3D is tough enough to take the pounding punishment of rough seas or a race across the lake.

Completely waterproof - even saltwater-proof your LCR 3D will provide you with many years of thoroughly reliable operation.

In the unlikely event that your Humminbird does require repairs, we offer an exclusive Service Guarantee - free of charge during the first year after your purchase, and available at a reasonable rate after the one-year warranty period. Complete details are provided at the end of this manual.

### WHAT YOU HAVE

Before installing your new LCR 3D, please ensure that the following parts are all included in the product box:

Item	Part No.
LCR 3D depth sounder	LCR 3D
Sensor with 20' cable	SHS-9
Gimbal mounting bracket	G-LCR-P
48" power cable	PC-10
Mounting knobs	MKH-LCR
Hole cover	HC

If any item is missing, please see your Humminbird dealer for a replacement or contact Humminbird at our toll-free Customer Service Hotline, listed inside the back cover. In addition to the parts supplied with your LCR 3D, you will need the following for installation and operation:

- A drill and drill bits
- Phillips-head screwdriver
- Flat-head screwdriver
- Ruler or measuring tape
- Pencil or pen
- 12-volt DC power source (your boat's battery)
- 1-amp fuse

### **CABLE CONNECTIONS**

The back of the LCR 3D has a connector for power input, labeled #1, and sensor input, labeled #2. The power and sensor cables supplied with your unit are also labeled. When connecting the cables to your LCR 3D, be sure to orient the alignment guides inside the connectors correctly. It is possible to force the connector together incorrectly. Also, care should be exercised when removing the cables from the unit. Grip the cable on the head when removing. Cables can be damaged if they are removed by pulling the wires.



## ACCESSORIES

The Trolling Motor Mount adapter, which mounts the sensor on the foot of a trolling motor, gives excellent readings with no interference from the electric motor. Please note, however, that the LCR 3D area of coverage is not round, but elongated side to side. As a result, the display can become disorienting when the trolling motor is turned. Remember that terrain shown on the left of the LCR 3D screen is to the left of the transducer, not necessarily left of the boat.

Item	Part #
Trolling motor adapter plate	AD-STM-7



Humminbird also offers the following accessories. Note that, for installation on a larger boat where the transducer is located well away from the LCR 3D, you may need to purchase the 10' sensor extension cable before beginning installation. Other accessories enhance the performance and capabilities of your LCR 3D, and can be added at any time.

For more information on these accessories, contact your local Humminbird dealer or call our toll-free Customer Service Hotline, listed inside the back cover.

Item	Part No.	Use
10' cable	EC-9	Extends transducer cable
Swivel Base	SM-LCR	Allows unit to swivel 360°
Video	VID-1	Complete Guide to Humminbird Depth Sounders - VHS

## TESTING THE INSTALLATION

After installing your transducer, LCR 3D, and cables, you should test the installation. Testing should be performed on the water, since that is the only way to check your sensor's performance.

With your boat at idle, press the POWER button to turn the unit on. The LCR 3D performs a self-test on its electronics, then automatically selects the right depth range and sensitivity level for conditions. Momentarily, you'll see the reading start to "march" across the screen from right to left and a digital depth readout in the upper right corner.

Increase your boat speed to ensure that you get a continuous bottom reading as the boat moves. Your sensor is designed to operate at up to 75 mph, however exercise caution when operating any boat at high speed.

If the LCR 3D performs well at idle or slow speeds, but the display is not continuous at higher speeds, the sensor is not installed properly. Air bubbles or turbulence from the boat hull are passing across the sensor face, blocking the transmitted signal. By following the instructions in "Mounting the Sensor," you can make simple adjustments that should fix the problem.

NOTE: If other problems occur, see "Troubleshooting" later in this manual for tips from the Humminbird engineers. If you don't find the solution there, call our toll free Customer Service Hotline and speak with one of our highly trained customer service representatives.

This section explains how to run the LCR 3D simulator for practice and how to start the LCR 3D for actual use. You're also shown how to use VIEW and BEAM - the buttons that let you control the display of underwater images on the LCR 3D screen.

You should read this section and Section 5, "Select System Functions", as you first learn to use the LCR 3D. Doing so will ensure you make the most of its many features.

The first part of this section explains the built-in simulator. The remaining instructions can be followed while using the simulator or in actual operation.





## USING THE BUILT-IN SIMULATOR

The LCR 3D includes a built-in simulator that helps you learn to use your new equipment. The simulator displays a typical underwater scene, and lets you practice with the controls.

The unit must be turned off before you start the simulator. To activate it, press down and hold the POWER button until a chirping sound begins. Release the button, and the built-in simulator begins displaying a typical LCR 3D reading.

You can use the simulator to learn the functions explained in the rest of this manual, just as if you were getting actual on-the-water readings. To turn off the simulator, turn off the unit by pressing the POWER button again.

Of course, the best way to learn is with actual use, especially in familiar waters. If you know what's below and see it on-screen, you'll quickly become a LCR 3D expert.

The LCR 3D offers function selection with front panel buttons. (Note that to select something with a button, you must press it fully so that you hear a "chirp" sound.)

You can learn to use these features by actual operation, or when using the simulator.

Press the POWER button once to turn the LCR 3D on. Pressing it again turns the LCR 3D off. When the unit is off, keeping POWER pressed for about 2 seconds starts the built-in simulator.

During night operation, press the LIGHT button once to turn the back light on high, and a second time to select low intensity. Press LIGHT again when you want to turn backlighting off.

In either actual operation or simulation, you see a 3-dimensional, underwater image that shows the bottom, any objects between the bottom and your boat, and the current depth.

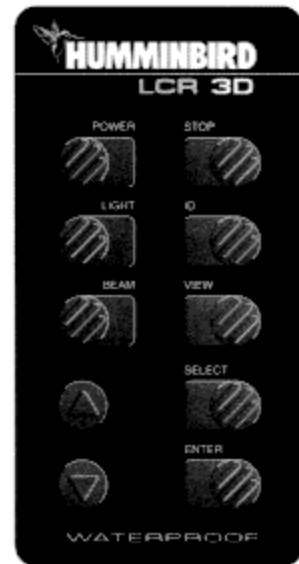

## WHAT YOU SEE ON-SCREEN

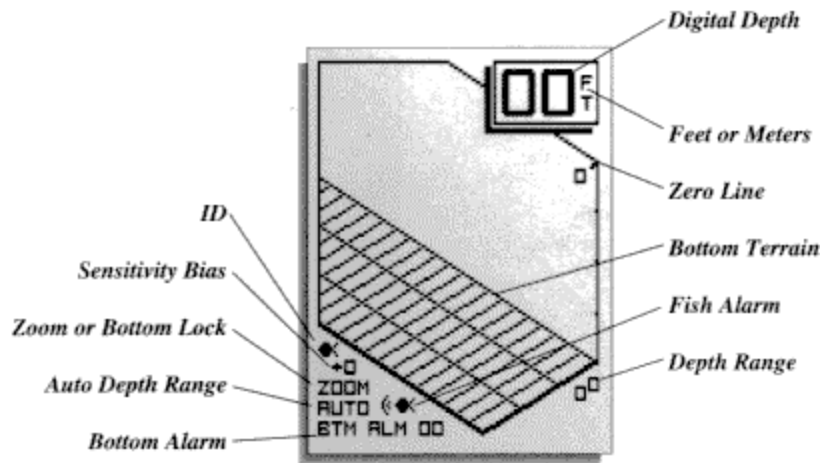

The 3-dimensional image you see reflects the way 3-dimensional sonar works. The sonar projects a narrow beam front-to-rear, and a broad beam left-to-right. The LCR 3D interprets the sonar returns to assemble the image displayed on the screen. As you view this image, your boat is at the center of the leading edge, traveling toward the right. What's displayed on the screen is what's immediately behind you. The image is updated constantly as you travel through the water.

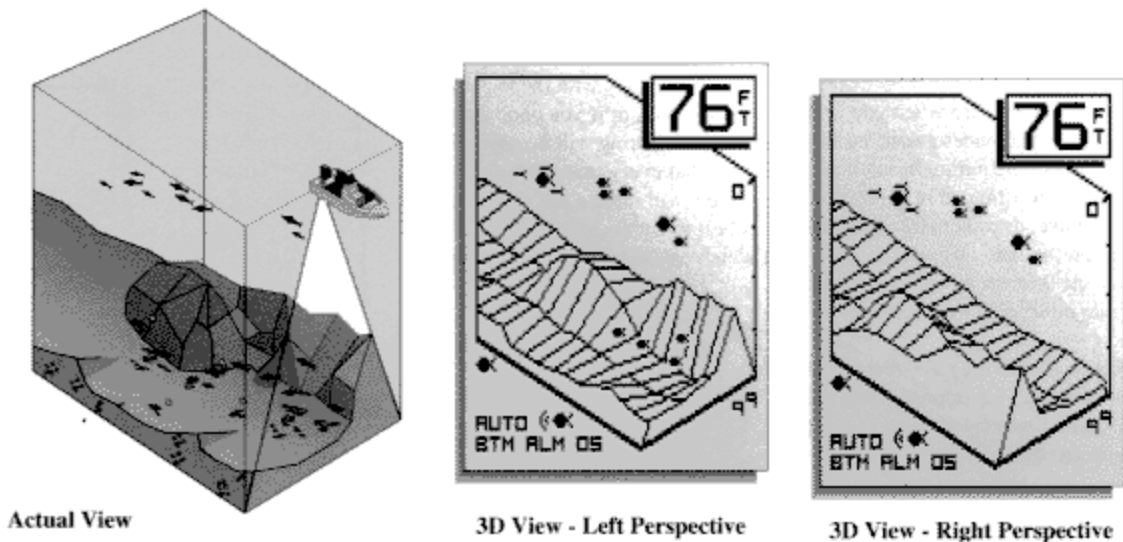

There are three different ways to view the sonar information, each is accessed by pressing the VIEW button.

The 3D view is what you see when you first power the unit up, and provides a detailed three dimensional picture of the terrain beneath your boat. This view can be oriented in two different ways, left perspective, or right perspective to suit your individual preference. Adjusting the perspective is done through the select system - see Custom Program in Section 5 for detailed instructions.

Left perspective orients the three dimensional picture so that objects to the right of your boat are shown on the right of the screen, and objects to the left of your boat are shown on the left side of your screen.

Right perspective is opposite this, so objects to the right of your boat are shown on the left side of the screen. If you are happy with the factory setting of left perspective, or if you choose to use right perspective, your setting will be remembered by the LCR 3D so that every time you use your unit, the perspective will remain the same until you change it. It is best to try the unit in familiar water to determine which option best suits your needs.

The 2D view provides a side view of terrain beneath your boat. This view will be familiar to users of other LCR products. All the information collected in the 45 degree area of coverage is shown, but is compressed into a 2 dimensional view.

The 2D view offers the additional benefit of individual beam selection. Each of the four sonar beams may be viewed independently or all four beams may be combined into one view. This unique beam control allows you to pinpoint the location of fish relative to your boat as well as their depth. Note: The direction of individual beam control is controlled by the perspective discussed previously.

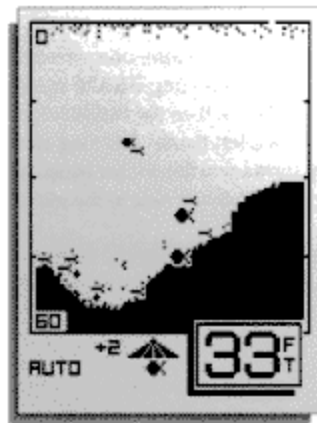

2D View - All Beams

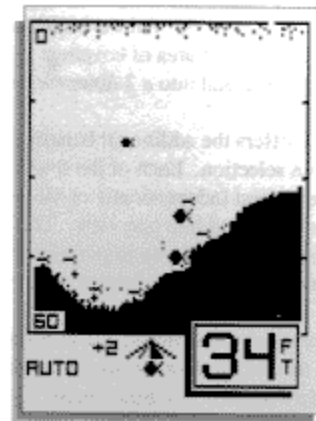

2D View - Individual Beam

See "Custom Program" for adjustment instructions.

Normally, when selecting the 2D view, all four beams will be selected. This is indicated by an onscreen symbol. Pressing the BEAM button once selects the right outside beam only. Pressing BEAM again selects the inside right beam, then the inside left beam, and finally the outside left beam. Viewing each beam individually shows you the terrain beneath your boat in sections, from one side to the other.

Note: The Beam symbol at the bottom of the display shows which beams are currently in use.

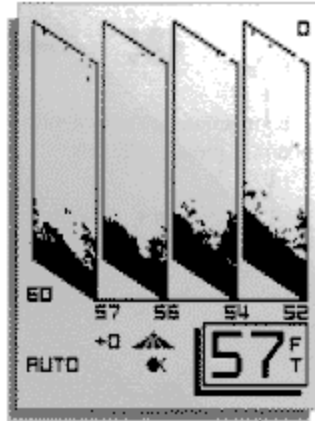

Quad-Beam® View

Pressing the VIEW button again will display the unique Quad-Beam® view in which all four beams are displayed side by side on-screen. This is similar using four different depth sounders simultaneously, with the sensors aimed in different directions. Pressing the VIEW button again will return you to the 3D view.

Three sizes of fish symbols are used to depict fish.



Structure or thermoclines are shown with individual pixels or groups of pixels.



ID "ties" the fish to the bottom beneath it for location in the 3D view.



A Word About Fish Size...

The size of the fish symbol used to depict fish is based on the sonar return strength of that fish regardless of its depth or position relative to your boat. This is called "normalizing". The size of the fish symbol represents the relative strength of return for that fish, which is often a good indicator of fish size, but different species of fish have different sonar characteristics.

## LCR 3D BUTTON FUNCTIONS

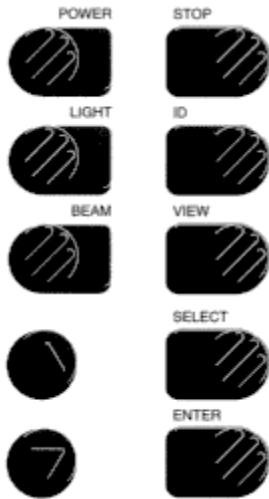

The STOP button freezes the display and flashes the digital depth as a reminder. The Total Sensitivity Update feature of the LCR 3D allows you to stop the display, and adjust the sensitivity to provide the best representation of the terrain beneath your boat. Pressing STOP again will restart display movement.

The ID button helps to differentiate fish from brush or structure and does this in different ways depending on the view. Whenever ID is active, a fish symbol is shown at the bottom of the screen. In the 3D view, ID turns on "strings" which attach fish to the bottom directly beneath them. As with any perspective view, a fish floating above the bottom would be difficult to tell its position in the view. The ID strings show you where each fish is relative to the bottom, so you know if it is to the left or right of your boat.

In the 2D view, ID performs this function in a slightly different way. Fish, which are normally shown as pixels, are shown as the same three symbols used in the 3D view. Also, the area of the display beneath the bottom is blacked-in to help better visualize the underwater view. Turning ID off provides the "raw" sonar information, and lets you do the interpretation.

In the Quad-Beam® view the raw sonar information is normally displayed for each beam. The ID button blacks-in the area of the display beneath the bottom of each beam, but does not display fish symbols.

BEAM, as already discussed, allows you to select each of the four sonar beams individually, or use all four simultaneously. BEAM has no function in the 3D or Quad-Beam® view, as these views must use all four beams together to generate the image.

VIEW, as discussed previously, switches the LCR 3D between the 3D, 2D and Quad-Beam® views.

The remaining four buttons are the select system and control on-screen menus. See Section 5.

## SELECT SYSTEM

The previous section explains the buttons that let you control the display of screen images. This section shows you how to use the LCR 3D "Select System" to choose from a wealth of useful features and functions.

When you press the SELECT button, you see a menu that offers the following functions for further adjustment:

- Sensitivity
- Depth Range
- Bottom Alarm
- Fish Alarm
- Zoom
- Bottom Lock
- Custom Program
- Diagnostic

Note: Press STOP to keep the menus on-screen for a longer period of time.

To adjust any of these, press SELECT until a menu appears for the function you want. (The list rotates by one choice each time you press SELECT.)

As you select a function, on-screen instructions tell you how to use the arrow buttons and ENTER for adjustment. When first learning, you should also refer to the following pages.

After you adjust any function, the display returns to its full- screen reading. Note that the last function you select stays "active"-you can adjust it without having to press SELECT again. For example, if you often use Zoom, you can select it once, then switch it on and off by simply pressing ENTER.

The menu Select System works in all three views- although the following descriptions are illustrated in the 3D view unless there are significant differences in operation.

### 1. Selecting Sensitivity;

Factory setting: +0, Digital Filter On

The LCR 3D automatically adjusts to the proper amount of sensitivity for conditions (i.e. depth). You can bias the setting + or - 5 levels to suit your personal taste. Increasing the sensitivity adjustment can cause the display of very small targets, thermoclines and second returns (in 2D view) which might not be displayed at the +0 setting. If you want to manually adjust Sensitivity, select SENSITIVITY and press the UP or DOWN arrow button to adjust. For example, if you press the UP arrow twice, Sensitivity remains 2 settings higher than the normal automatic setting.

The Sensitivity menu also controls the Digital Filter. This is a filter that prevents other depth sounders on your boat or another boat from interfering with the LCR 3D. It is also effective in eliminating engine noise or other types of electrical interference from affecting your unit. Normally, this filter should be ON, however if you are using a "through the hull" sensor mount, better results may be achieved with the Digital Filter OFF.

NOTE: The Digital Filter may somewhat adversely affect high-speed readings.

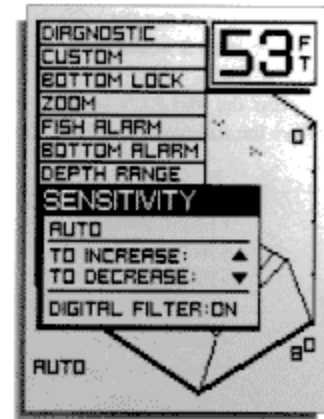

▲ ▼ Adjusts sensitivity bias

## 2. Setting Depth Range;

Factory setting: AUTOMATIC

When you turn the LCR 3D on, it finds the bottom, sets the ideal Depth Range, and automatically adjusts the range as the depth changes. In this "Auto Depth Range" mode, the bottom is always displayed for easy-to-understand readings (and AUTO appears at the bottom of the screen).

If you prefer, you can turn Auto Depth Range off. Select DEPTH RANGE, press ENTER, and adjust the Depth Range with the UP or DOWN arrow key. You can set Depth Range up to 99'.

In this "Manual Depth Range" mode, the 3D view shows a flat grid if the bottom is below the depth you have set.

In the 2D view the bottom will simply not be seen on screen.

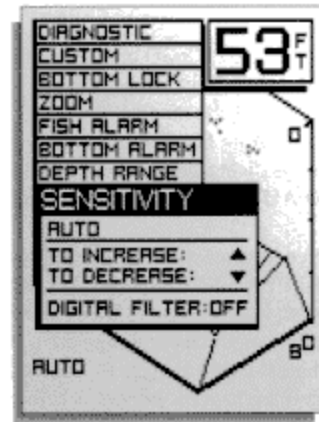

ENTER Enables Digital Filter

## 3. Enabling Bottom Alarm;

Factory setting: OFF

The Bottom Alarm lets you specify the minimum depth you want to maintain. To use it, select BOTTOM ALARM; then, press the ENTER button to activate the alarm, and the UP or DOWN arrow key to adjust the depth at which the alarm will sound. A Bottom Alarm indicator and the selected depth are displayed when this function is on.

While Bottom Alarm is on, you'll hear a continuous chirping sound when the bottom directly under your boat gets shallower than you defined. This is very handy for alerting you to shallow water or helping you to maintain position over structure.



▲ ▼ Adjusts Alarm Depth

ENTER Enables

#### 4. Enabling Fish Alarm;

Factory setting: OFF

The Fish Alarm alerts you with a chirping sound whenever the LCR 3D detects fish (or other objects) above the bottom. You can set it for large fish, large and medium fish, or all fish.

To activate it, select FISH ALARM and press ENTER. The alarm is initially set for large fish; press the UP or DOWN arrow to display available settings. An on-screen fish symbol shows when the alarm is on.

NOTE: Displayed fish sizes generally indicate relative fish size, but different species may have different sonar characteristics. Strength of return is corrected for depth, so shallow fish don't appear larger than deeper fish.

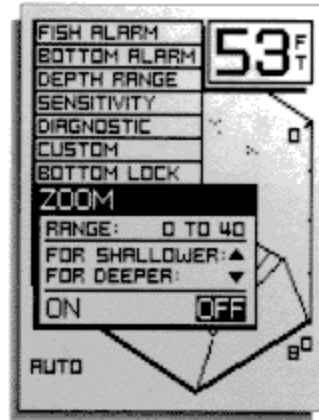

▲ ▼ Adjusts Zoom Range  
ENTER Enables Zoom

#### 5. Using Zoom

Factory Setting: OFF

Zoom provides a detailed view of a portion of the screen image and can be used in any view. The zoom range, or area to be enlarged, depends on the current depth range: 10' 20', or 40' ranges are available. There are two ways to use zoom: use the UP or DOWN arrow to adjust the zoom range to the area to be enlarged, using the digital range indicator in the zoom menu as a reference, or by watching the zoom preview bars on-screen. Pressing ENTER activates zoom. You may also activate Zoom first, and then use the UP and DOWN arrows to lower the zoom range to the area of interest. The Zoom preview bars will always be present on-screen if the zoom menu was used last. This allows adjustment of the Zoom range when the menu is not present.

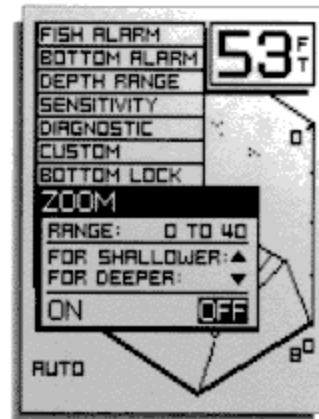

▲ ▼ Adjusts Zoom Range  
ENTER Enables Zoom



*Zoom Preview - 3D*

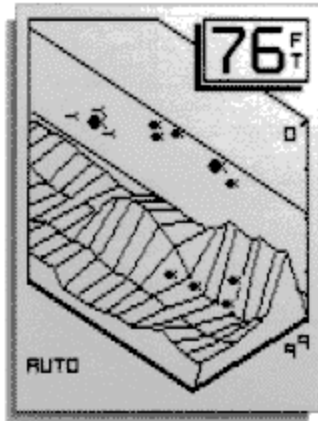

*Zoom View - 3D*

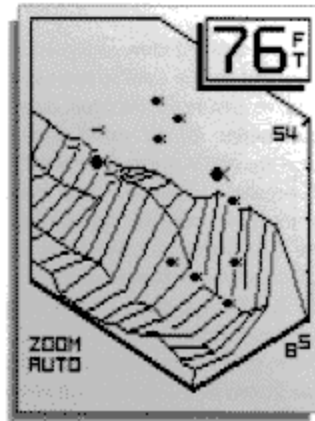

### 6. Using Bottom-Lock;

Factory setting: OFF

Bottom-Lock provides an up-close view like Zoom, except that in this case the zoomed view automatically moves up or down to stay on the bottom. To use this feature, select BOTTOM LOCK and press ENTER. A BL indicator and the range of the display are shown when Bottom-Lock is on.

This is an ideal feature for finding structure or locating fish near the bottom.

Remember: If Bottom-Lock is the last function selected, you can use the ENTER button to switch Bottom-Lock on and off without having to press SELECT first.



**ENTER** Enables Bottom Lock

### 7. Adjusting Custom Program

Factory Settings:

Display Speed: 8  
 Contrast: 8  
 Perspective: Left  
 Units: Feet

The LCR 3D lets you customize several aspects of its operation:

1. You can adjust the speed at which display updates. Matching this rate to the speed of your boat provides the most accurate view of the underwater terrain.
2. The contrast level of the LCD display can be adjusted to optimize viewing from any angle.
3. The perspective of the on-screen view can be changed between left and right perspective. (See Section 5 for more details.)

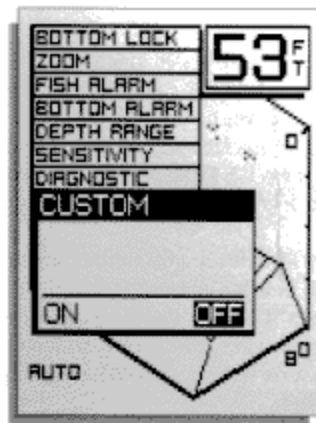

**ENTER** Enables Custom Program

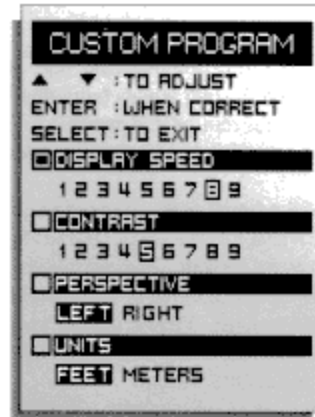

- ▲ ▼** Adjusts Functions
- ENTER** Selects Function to Adjust
- SELECT** Exits Custom Program

4. The depth readout can be changed from feet to meters.

To adjust any of these functions, press ENTER until the black box preceding the function is blacked-in, use the UP and DOWN arrow keys to adjust the setting, and then press SELECT if no other adjustments are required.

### 8. Using Diagnostic

Factory setting: OFF

The Diagnostic function displays "raw" sonar information from the four beams individually. By comparing the four returns it is possible to fine tune your installation and to troubleshoot problems with the system.

The top of the return is the origination of the signal or the surface of the water, and the large area of the return is the bottom. Any deviations in the area between the two are fish or other targets not attached to the bottom. The horizontal width of the bottom return represents the strength of the sonar signal reflected off the bottom.

Diagnostic is especially helpful when installing the sensor of the LCR 3D, since the strength of an individual beam can be compared to the other beams. This feature can be used to ensure that the location you have chosen for the sensor is not degrading the performance of the LCR 3D. A noticeably weaker signal in one beam than in the others indicates a problem with the sensor location. By comparing readings taken from various inside hull locations to those taken outside the hull relative signal loss, and thus performance, for inside hull mounting can be determined.



**ENTER** Enables Diagnostic

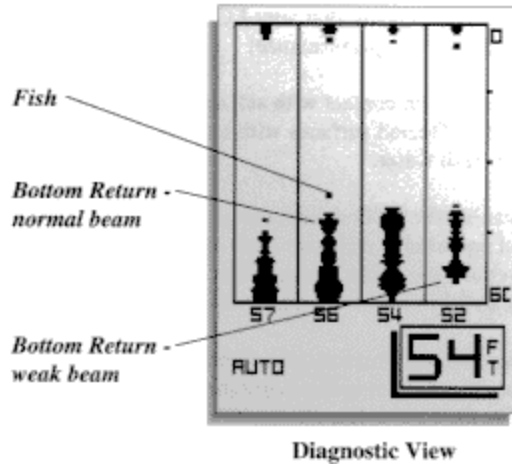

The diagnostic function is also very helpful during troubleshooting to determine where a problem in the system lies. A "weak" beam is usually caused by an improper sensor installation, however, if your sensor is mounted outside the hull, the problem is most likely in the sensor or the LCR 3D itself.

- Operating Frequency: 455 KHz
- Power Requirement: 10 - 16 VDC
- Power Cable Length: 48"
- Sensor (standard): SHS-9
- Sensor Cone Angle: 45 degrees side-to-side  
16 degrees front-to-back
- Depth Ranges: 0 to 10', 20', 40', 60', 80' and 99'
- Zoom Ranges: 10', 20' and 40'
- Unit Construction: high-impact polycarbonate housing
- Unit Dimensions: 8 1/4" x 5 3/4" x 2"
- Display: super-twist liquid crystal
- Viewing Area: 3 " x 4 "
- Matrix Configuration: 128 x 128 pixels