

**ALTO-SHAAM®**

**Combitherm®**  
**Combination  
Oven / Steamer**

**ES ELECTRIC  
COMBITOUCH®  
SERIES**



**6•10**

**10•10**

**7•14**

**10•18**

**12•20**

**20•20**

**VHes-5**

**VHes-10**



**• INSTALLATION**

W164 N9221 Water Street • P.O. Box 450 • Menomonee Falls, Wisconsin 53052-0450 USA

PHONE: 262.251.3800 • 800.558.8744 USA/CANADA

FAX: 262.251.7067 • 800.329.8744 U.S.A. ONLY

WWW.ALTO-SHAAM.COM

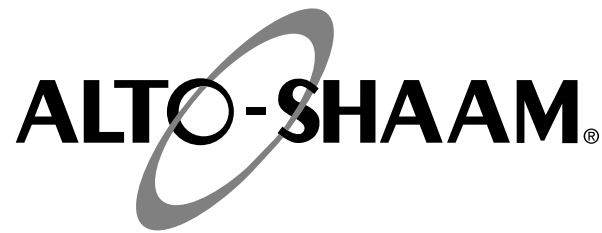

Delivery .....1  
Unpacking .....1  
Safety Procedures and Precautions .....2

**Installation**

Site Requirements .....3  
Ventilation Requirements .....3  
Positioning on Site .....4  
Lifting Instructions .....5  
Leveling .....6  
Stand Installation .....6  
Common Specifications .....7  
Specifications, 6•10es .....8  
Specifications, 6•10esi .....9  
Specifications, 6•10esiN .....10  
Specifications, 10•10es .....11  
Specifications, 10•10esi .....12  
Specifications, 10•10esiN .....13  
Specifications, 7•14es .....14  
Specifications, 7•14esi .....15  
Specifications, 10•18es .....16  
Specifications, 10•18esi .....17  
Specifications, 12•20es .....18  
Specifications, 12•20esi .....19  
Specifications, 20•20es .....20  
Specifications, 20•20esi .....21

Electrical Connection .....22  
Mobile Equipment Restraint .....24  
Water Quality Requirement .....25  
Water Connections .....26  
Grease Collection Installation .....28  
Installation Checklist .....29  
Error Codes .....30

**Ventless Hood Option**

Condensate Drain .....36  
Filter Door Latch .....36  
Operation .....37

**Warranty**

Original Equipment Limited Warranty .....38  
Transportation Damage and Claims .....39

# ALTO-SHAAM®

## DELIVERY

This Alto-Shaam appliance has been thoroughly tested and inspected to ensure only the highest quality unit is provided. Upon receipt, check for any possible shipping damage and report it at once to the delivering carrier. *See Transportation Damage and Claims section located in this manual.*

This appliance, complete with unattached items and accessories, may have been delivered in one or more packages. Check to ensure that all standard items and options have been received with each model as ordered.

Save all the information and instructions packed with the appliance. Complete and return the warranty card to the factory as soon as possible to ensure prompt service in the event of a warranty parts and labor claim.

This manual must be read and understood by all people using or installing the equipment model. Contact the Alto-Shaam Tech Team Service Department if you have any questions concerning installation, operation, or maintenance.

**NOTE:** All claims for warranty must include the full model number and serial number of the unit.

## UNPACKING

1. Carefully remove the appliance from the carton or crate.

**NOTE:** Do not discard the carton and other packaging material until you have inspected the unit for hidden damage and tested it for proper operation.

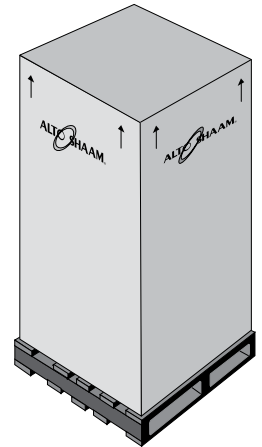

2. Read all instructions in this manual carefully before initiating the installation of this appliance.

**DO NOT DISCARD THIS MANUAL.**

This manual is considered to be part of the appliance and is to be provided to the owner or manager of the business or to the person responsible for training operators. *Additional manuals are available from the Alto-Shaam Tech Team Service Department.*

3. Remove all protective plastic film, packaging materials, and accessories from the appliance before connecting electrical power. Store any accessories in a convenient place for future use.

## CAUTION



**TO PREVENT PERSONAL INJURY,  
USE CAUTION WHEN MOVING OR  
LEVELING THIS APPLIANCE.**

**THE INFORMATION CONTAINED IN THIS MANUAL IS IMPORTANT FOR THE PROPER INSTALLATION OF THIS OVEN. PLEASE READ CAREFULLY AND RETAIN FOR FUTURE REFERENCE.**

**IMPROPER CONNECTION OF THIS APPLIANCE WILL NULLIFY ALL WARRANTIES.**

**LES INFORMATIONS CONTENUES DANS CE MANUEL SONT IMPORTANTES POUR L'INSTALLATION L'UTILISATION ET L'ENTRETIEND DE CE FOUR. S'IL VOUS PLAIT LISEZ-LE TRES ATTENTIVEMENT ET CONSERVEZ-LE.**

**LA NON-APPLICATION DE CES CONSIGNES ANNULE TOUTES GARANTIES.**

# SAFETY PROCEDURES AND PRECAUTIONS

Knowledge of proper procedures is essential to the safe operation of electrically and/or gas energized equipment. In accordance with generally accepted product safety labeling guidelines for potential hazards, the following signal words and symbols may be used throughout this manual.

<b>DANGER</b>	
	<b>Used to indicate the presence of a hazard that WILL cause severe personal injury, death, or substantial property damage if the warning included with this symbol is ignored.</b>

<b>WARNING</b>	
	<b>Used to indicate the presence of a hazard that CAN cause personal injury, possible death, or major property damage if the warning included with this symbol is ignored.</b>

<b>CAUTION</b>	
	<b>Used to indicate the presence of a hazard that can or will cause minor or moderate personal injury or property damage if the warning included with this symbol is ignored.</b>

<b>CAUTION</b>	
<b>Used to indicate the presence of a hazard that can or will cause minor personal injury, property damage, or a potential unsafe practice if the warning included with this symbol is ignored.</b>	

**NOTE:** Used to notify personnel of installation, operation, or maintenance information that is important but not hazard related.

1. This appliance is intended to cook, hold or process foods for the purpose of human consumption. No other use for this appliance is authorized or recommended.
2. This appliance is intended for use in commercial establishments where all operators are familiar with the purpose, limitations, and associated hazards of this appliance. Operating instructions and warnings must be read and understood by all operators and users.
3. Any troubleshooting guides, component views, and parts lists included in this manual are for general reference only and are intended for use by qualified technical personnel.
4. This manual should be considered a permanent part of this appliance. This manual and all supplied instructions, diagrams, schematics, parts lists, notices, and labels must remain with the appliance if the item is sold or moved to another location.

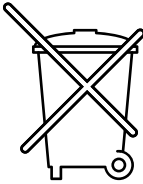
<b>NOTE</b>	
	<b>For equipment delivered for use in any location regulated by the following directive: DO NOT DISPOSE OF ELECTRICAL OR ELECTRONIC EQUIPMENT WITH OTHER MUNICIPAL WASTE.</b>

<b>CAUTION</b>	
	<b>WHEN WELDING ANY STAINLESS STEEL COMPONENTS ON THIS APPLIANCE, THE ELECTRONIC CONTROL BOARDS MUST BE ISOLATED FROM THE APPLIANCE.</b>

# INSTALLATION

## SITE INSTALLATION

### DANGER



IMPROPER INSTALLATION, ALTERATION, ADJUSTMENT, SERVICE, OR MAINTENANCE COULD RESULT IN SEVERE INJURY, DEATH, OR CAUSE PROPERTY DAMAGE.

READ THE INSTALLATION, OPERATING AND MAINTENANCE INSTRUCTIONS THOROUGHLY BEFORE INSTALLING OR SERVICING THIS EQUIPMENT.

### DANGER



AVERTISSEMENT : UNE INSTALLATION, UN AJUSTEMENT, UNE ALTÉRATION, UN SERVICE OU UN ENTRETIEN NON CONFORME AUX NORMES PEUT CAUSER DES DOMMAGES À LA PROPRIÉTÉ, DES BLESSURES OU LA MORT.

LIRE ATTENTIVEMENT LES DIRECTIVES D'OPÉRATION ET D'ENTRETIEN AVANT DE FAIRE L'INSTALLATION, OU L'ENTRETIEN DE CET ÉQUIPEMENT.

### CAUTION



TO PREVENT PERSONAL INJURY, USE CAUTION WHEN MOVING OR LEVELING THIS APPLIANCE.



### DANGER



DO NOT store or use gasoline or other flammable vapors or liquids in the vicinity of this or any other appliance.

## SITE INSTALLATION

### INSTALLATION CODES & STANDARDS

The following codes and standards are required for installation of this oven: AIR SUPPLY, ELECTRICAL CONNECTIONS, WATER CONNECTIONS, AND WASTE WATER DISCHARGE.

#### NOTE:

Where automatically operated appliances are vented through a ventilating hood or exhaust system equipped with a damper or with a power means of exhaust, provisions shall be made to allow the equipment to operate only when the damper is open to a position to properly vent the appliance and when the power means of exhaust is in operation.

*IN ACCORDANCE WITH NFPA 54*

*COMMONWEALTH OF MASSACHUSETTS ONLY.*

### VENTILATION REQUIREMENTS

A steam ventilation hood is mandatory for the operation of the oven. The ventilation hood must be installed in accordance with local building codes for the steam exhaust and must protrude 12-inches to 20-inches (300 to 500mm) over the front side of the oven. A grease filter must be located in the protruding area of the hood. Grease filters should be thoroughly cleaned on a regular basis following manufacturer's instruction. Ventilation hoods must ensure an adequate amount of incoming air during operation and must be operated whenever the combination oven/steamer is used in order to avoid the accumulation of condensation in the hood area.

# INSTALLATION

## SITE INSTALLATION

### CAUTION



THE APPLIANCE MUST REMAIN ON THE PALLET WHILE BEING MOVED TO THE INSTALLATION SITE BY FORK LIFT OR PALLET LIFT TRUCK.

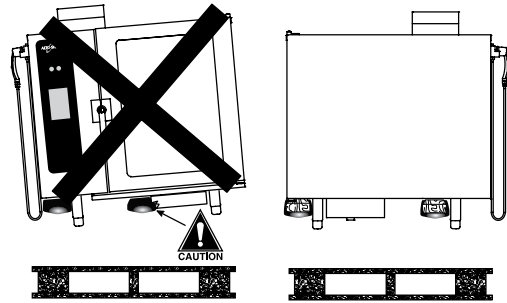
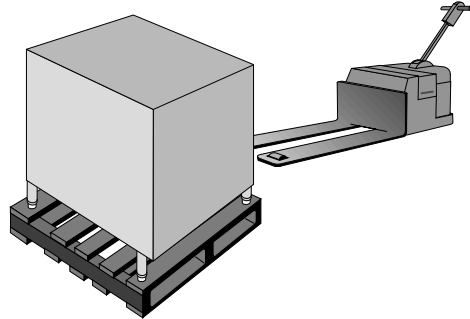
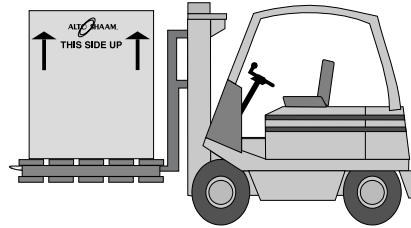

**NOTE:** Note dimensions required for doorways and aisles for access of the oven and pallet to the installation site. Transport the oven in an upright and level position only. Do not tilt the oven.

**NOTE:** To avoid equipment damage, observe attention label on oven for area to avoid with lifting fork.

### POSITIONING ON SITE

Stand the oven in a level position. Use the adjustable feet to overcome an uneven floor and ensure that the unit is level.

It is strongly recommended that table top models be mounted on a factory supplied stand or a stand that is stable, open, and level. Recommended height is 23-inches (584mm).

Adjust the height of floor models for smooth access of the trolley or cart. When positioning the oven, observe the minimum space allocation requirements shown.

To insure proper operation, the installation of this oven must be completed by qualified technicians in accordance with the instructions provided in this manual. Failure to follow the instructions provided may result in damage to the oven, building, or cause personal injury to personnel.

### MINIMUM CLEARANCE REQUIREMENTS

<b>LEFT SIDE</b>	6" (152mm) MINIMUM
	18" (457mm) SERVICE ACCESS RECOMMENDED
	20" (508mm) FROM HEAT PRODUCING EQUIPMENT
<b>RIGHT SIDE</b>	4" (102mm)
<b>BACK</b>	4" (102mm) FOR PLUMBING
<b>TOP</b>	20" (508mm) FOR AIR MOVEMENT

**NOTE:** Additional clearance is needed for service access. A minimum distance of 18-inches is strongly recommended. If adequate service clearance is not provided, it will be necessary to disconnect the gas, water, and drain to move the oven with a fork lift for service access. Charges in connection with inadequate service access is not covered under warranty.

# INSTALLATION

## SITE INSTALLATION

### Lifting Instructions

Remove banding before lifting. Place a spacer board(s) 24" in length, with a minimum height of 1-1/2" (mobile base units require 2-1/4" minimum height), on each fork to prevent damaging the door drip tray. Lift the unit from the front only, never from the side.

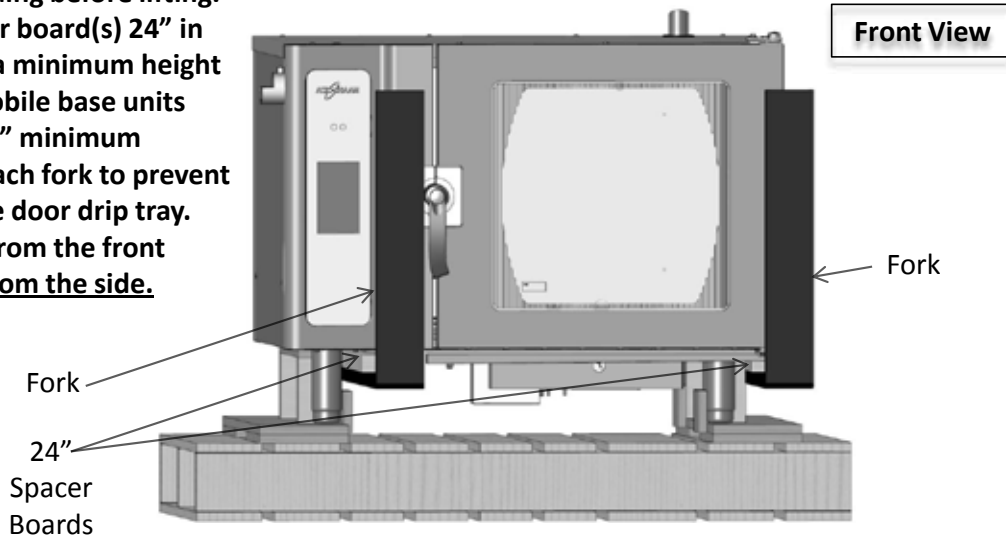

Adjust the forks so that they do not damage any of the components under the unit. The left fork should be located between the left legs and the door handle. The right fork should be located as close to the right legs as possible. Lift the unit high enough to remove the wooden pallet. Have a second person hold the unit from shifting. When moving the unit, drive slowly, keep it low to the ground, and use extreme caution.

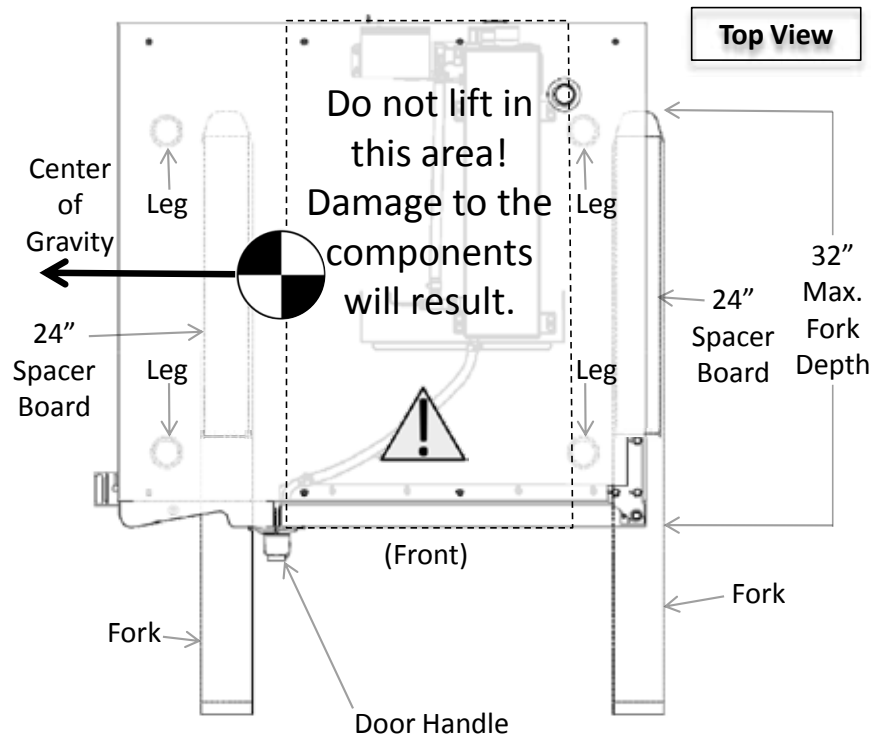

**DEPTH OF FORKS IS CRITICAL FOR UNITS EQUIPPED WITH GREASE COLLECTION TO AVOID DAMAGING THE PUMP**

# INSTALLATION

## SITE INSTALLATION

### POSITIONING REQUIREMENTS

- ❑ In order to ensure proper ventilation, a minimum distance of at least 6-inches (152mm) must be kept from the control panels side (left) of the oven and any adjoining surfaces.

**NOTE:** Additional clearance is needed for service access. A minimum distance of 18-inches is strongly recommended. If adequate service clearance is not provided, it will be necessary to disconnect the gas, water, and drain to move the oven with a fork lift for service access. Charges in connection with inadequate service access is not covered under warranty.

- ❑ Allow a minimum of 4-inches (102mm) from the right side of the oven to allow the door to open to at least a 90° angle. Fully opened, the door will extend up to a 225° angle. If the oven is furnished with the retractable door option, allow a minimum clearance of 6-1/2 inches (165mm).
- ❑ Allow a minimum clearance of 4-inches (102mm) from the back of the oven for plumbing connections.
- ❑ Allow a 20-inch (500mm) clearance at the top of the oven for free air movement and for the steam vent(s) located at the top.
- ❑ Do not install the oven adjacent to heat producing equipment such as fryers, broilers, etc. Heat from such appliances may cause damage to the controls of the Combitherm. Minimum clearance recommended: 20-inches (500mm)

Place the Combitherm oven on a stable, non-combustible level horizontal surface. For countertop models, the oven stand must be level. Level from front-to-back and side-to-side by means of the adjustable legs. In addition, the overall height of the oven should be positioned so the operating controls and shelves may be conveniently reached from the front.

When placing a countertop model on an oven stand, position the oven legs on the outside of the positioning pins.

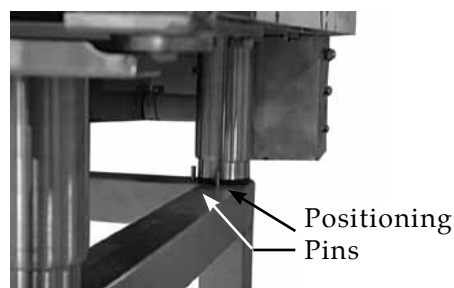
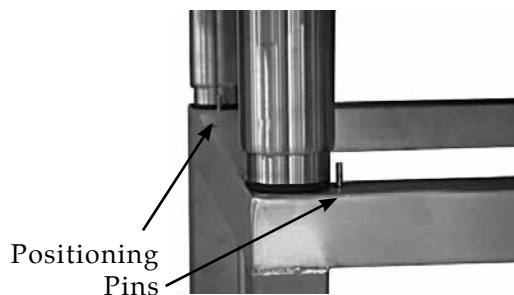
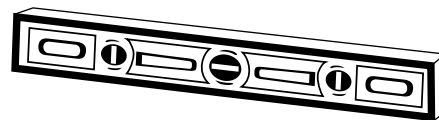
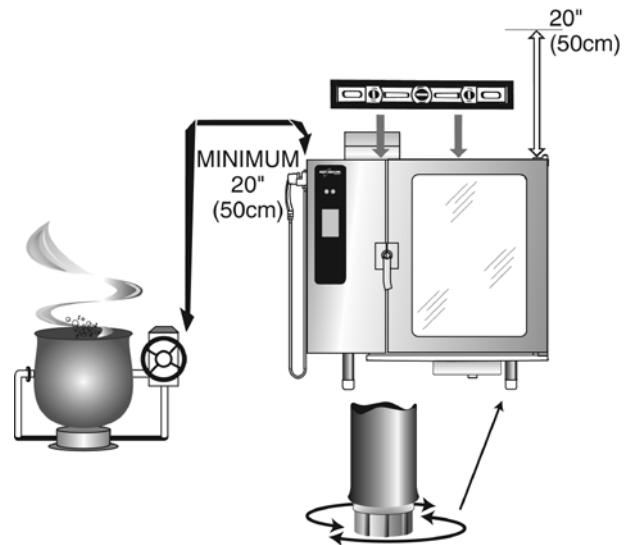
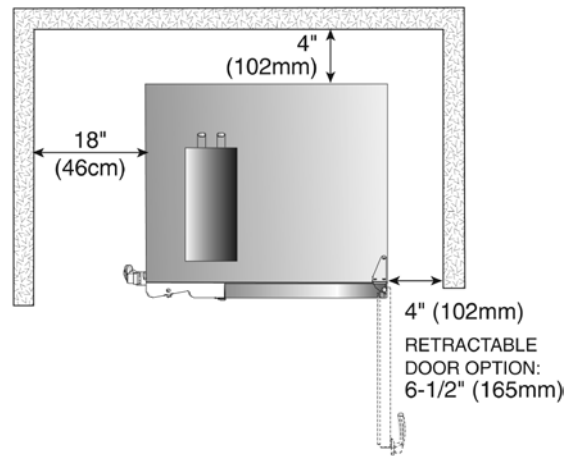



# INSTALLATION

## COMMON SPECIFICATIONS

<input type="checkbox"/> CombiGuard™ BWS Blended Water System (INCLUDES 50 GALLON TANK, 1 MEMBRANE & 3 FILTERS)	FI-28727
<input type="checkbox"/> CombiGuard™ BWS Replacement Filter Cartridge AMS-QT	FI-29316
<input type="checkbox"/> CombiGuard™ BWS Replacement Filter Cartridge SCLX2-Q	FI-29317
<input type="checkbox"/> CombiGuard™ BWS Replacement Prefilter Filter Cartridge CTO-Q	FI-29318
CombiGuard™ Triple-Guard Water Filtration System (INCLUDES 1 CARTRIDGE)	
<input type="checkbox"/> 6•10, 7•14, 10•18 (CombiGuard™ 10)	FI-23014
<input type="checkbox"/> 12•20, 20•20, stacked units (CombiGuard™ 20)	FI-28728
CombiGuard™ Triple-Guard Replacement Filter	
<input type="checkbox"/> 6•10, 10•10, 7•14, 10•18 (CombiGuard™ 10)	FI-26356
<input type="checkbox"/> 12•20, 20•20, stacked units (CombiGuard™ 20)	FI-28744
<input type="checkbox"/> Fry Basket, 12" x 20" (325mm x 530mm)	BS-26730
<input type="checkbox"/> Grilling Grate, 12" x 20" (325mm x 530mm)	SH-26731
<input type="checkbox"/> Mobile Grease Collection cart, 37" x 11-3/16" x 28-1/2" (940mm x 284mm x 724mm)	5014542
<input type="checkbox"/> Poultry Grease Collection Container 15" x 9-3/4" x 9-3/4" (381mm x 248mm x 248mm)	5014846
Shelf, Stainless Steel Wire	
<input type="checkbox"/> 6•10, 10•10	SH-2903
<input type="checkbox"/> 7•14, 10•18	SH-22584
<input type="checkbox"/> 12•20, 20•20	SH-22473
<input type="checkbox"/> Probe, Sous Vide	PR-34747
<input type="checkbox"/> Combitherm Cleaning Liquid — SPECIALLY FORMULATED FOR COMBITHERM OVENS ➔ TWELVE (12) CONTAINERS/CASE, 1 QUART (C. 1 LITER) EACH	CE-24750
<input type="checkbox"/> CombiClean® Tablets — SPECIALLY FORMULATED FOR COMBITHERM OVENS ➔ TWO (2) CONTAINERS/BOX, 90 PACKETS EACH CONTAINER	CE-28892
<input type="checkbox"/> Scale Free™ (CITRUS BASED, NON-CORROSIVE DELIMING PRODUCT) CASE = FOUR 4-LB BOTTLES; 4-LB BOTTLE MAKES 10 GALLONS	CE-27889
<input type="checkbox"/> Service Start-Up Check AVAILABLE THROUGH THE ALTO-SHAAM TECH TEAM SERVICE DEPARTMENT	SPECIFY AS REQUIRED

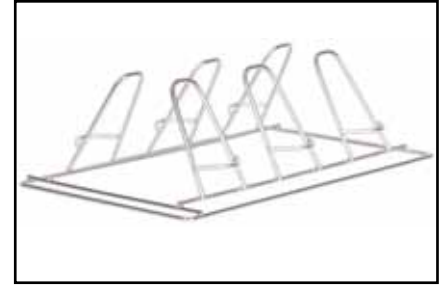

Six (6) Poultry Roasting Rack  
(FITS IN SIDE RAILS) 5014438



Six (6) Poultry Roasting Rack  
(PAN NOT INCLUDED) SH-23000

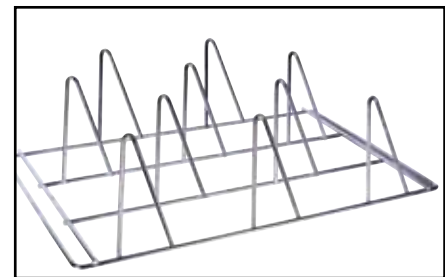

Ten (10) Poultry Roasting Rack  
SH-22634



Fry Basket BS-26730



Grilling Grate SH-26731

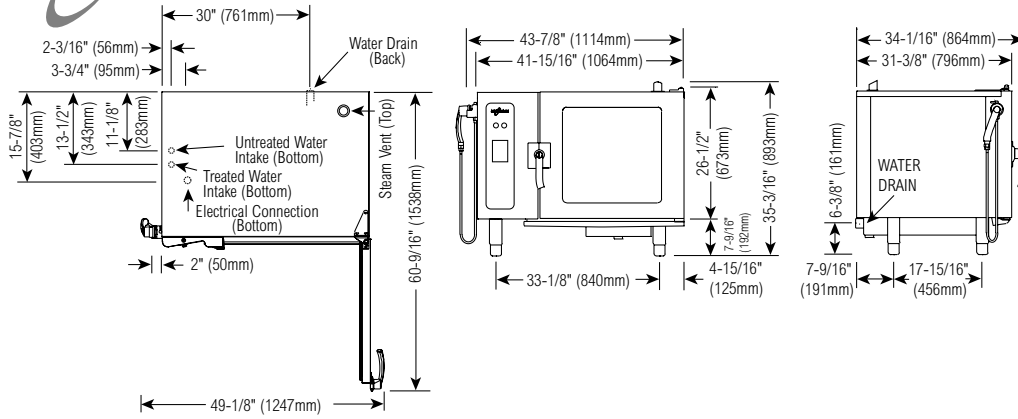

<b>STACKING COMBINATION DIMENSIONS: H x W x D</b>		<b>DIMENSIONS: H x W x D</b>					
<input type="checkbox"/> 6.10es over 6.10es	66-3/4" x 44" x 36-5/8" (1693 x 1115 x 930mm)	<b>EXTERIOR:</b> 35-3/16" x 43-7/8" x 34-1/16" (893mm x 1114mm x 864mm)					
<input type="checkbox"/> 6.10es over 10.10es	73-1/8" x 44" x 36-5/8" (1857 x 1115 x 930mm)	<b>EXTERIOR WITH RECESSED DOOR:</b> 35-3/16" x 47-7/8" x 34-1/16" (893mm x 1216mm x 864mm)					
<input type="checkbox"/> 6.10es over 7.14es	67" x 44" x 43" (1701 x 1115 x 1090mm)	<b>INTERIOR:</b> 17-3/4" x 23-1/2" x 21-1/16" (450mm x 597mm x 535mm)					
<input type="checkbox"/> 6.10es over 10.18es	72-3/4" x 44" x 43" (1845 x 1115 x 1090mm)						
<input type="checkbox"/> Mobile option with 5" (127mm) casters will add 2" (51mm) to the overall height							
<input type="checkbox"/> 6.10es over ASC-4E	74" x 44" x 44-1/2" (1878 x 1115 x 1130mm)						
<b>WATER REQUIREMENTS</b>		<b>WATER QUALITY MINIMUM STANDARDS</b>					
<p><b>TWO (2) COLD WATER INLETS - DRINKING QUALITY</b></p> <p><b>ONE (1) TREATED WATER INLET:</b> 3/4" NPT* * Can manifold off of one 3/4" line.</p> <p><b>ONE (1) UNTREATED WATER INLET:</b> 3/4" NPT*</p> <p><b>LINE PRESSURE:</b> 30 to 90 psi 2.8 to 6.2 bar</p> <p><b>WATER DRAIN:</b> 1-1/2" CONNECTION WITH A 2" MINIMUM AIR GAP INSTALLED AS CLOSE TO THE OVEN AS POSSIBLE</p>		<p>USING A WATER SUPPLY NOT MEETING ALTO-SHAAM'S MINIMUM WATER QUALITY STANDARDS WILL VOID THIS WARRANTY.</p> <p>It is the responsibility of the purchaser to ensure that incoming water supply is compliant with the specifications listed through adequate treatment measures. Installation of the CombiGuard™ Water Filtration System is recommended, but this system may not address all water quality issues present.</p>					
<b>CLEARANCE REQUIREMENTS</b>		<b>Contaminant Inlet Water Requirements (untreated water)</b>					
<b>LEFT</b> 6" (152mm)	<b>RECOMMENDED SERVICE ACCESS:</b> 18" (457mm) 20" (508mm) <b>FROM HEAT PRODUCING EQUIPMENT</b>	Free Chlorine Less than 0.1 ppm (mg/L)					
<b>RIGHT</b> 4" (102mm)	<b>TOP:</b> 20" (508mm) <b>FOR AIR MOVEMENT</b>	Hardness Less than 3 gpg (52 ppm)					
<b>BACK</b> 4" (102mm)	<b>BOTTOM:</b> 5-1/8" (130mm) <b>FOR LEGS</b>	Chloride Less than 30 ppm (mg/L)					
COUNTER-TOP INSTALLATIONS MUST MAINTAIN 4" (102mm) MINIMUM CLEARANCE FROM COUNTER SURFACE		pH 7.0 to 8.5					
		Alkalinity Less than 50 ppm (mg/L)					
		Silica Less than 12 ppm (mg/L)					
		Total Dissolved Solids (tds) Less than 60 ppm					
<b>INSTALLATION REQUIREMENTS</b>							
<ul style="list-style-type: none"> <li>Oven must be installed level.</li> <li>Hood installation is required.</li> <li>Water supply shut-off valve and back-flow preventer when required by local code.</li> </ul>							
<b>ELECTRICAL (DEDICATED CIRCUIT REQUIRED)</b>							
MODEL	VOLTAGE	PH	HZ	AMPS	kW	AWG	CORD & PLUG
6•10ES Touch	208 - 240	1*	60	44.0 - 50.0	9.1 - 12.0	AWG 6	no cord or plug
	208 - 240	3	60	25.2 - 28.4/ph	9.1 - 11.7	AWG 8	no cord or plug
	380 - 415	3	50/60	14.0 - 16.3/ph	9.0 - 11.7	AWG 12	no cord or plug
6•10ES	208 - 240	1*	60	40.8 - 47.0	8.5 - 11.2	AWG 6	no cord or plug
	208 - 240	3	60	23.5 - 27.0/ph	8.5 - 11.2	AWG 8	no cord or plug
	380 - 415	3	50/60	13.0 - 16.0/ph	8.5 - 11.2	AWG 12	no cord or plug

\*ELECTRICAL SERVICE CHARGE APPLIES

<b>WEIGHT</b>		<b>CAPACITY</b>	
NET	285 lb (129 kg)	FULL-SIZE PANS:	20" x 12" x 2-1/2"
SHIP	465 lb (211 kg)	GN 1/1:	530 x 325 x 65mm
CRATE DIMENSIONS: (L x W x H) 53" x 45" x 49" (1346 x 1143 x 1245mm)		GN 2/1:	650 x 530 x 65mm
		HALF-SIZE SHEET PANS:* ON WIRE SHELVES ONLY	18" x 13" x 1"
72 lb (33 kg) MAXIMUM			
VOLUME MAXIMUM: 45 quarts (57 liters)			

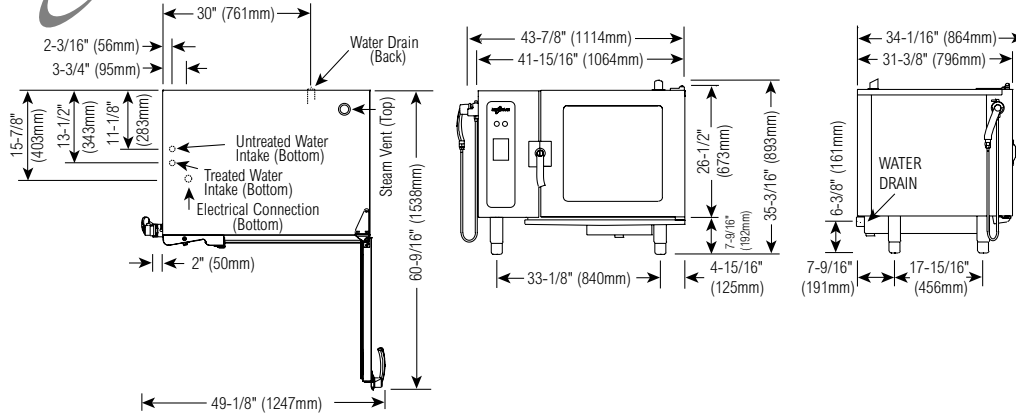

<b>STACKING COMBINATION DIMENSIONS: H x W x D</b>		<b>DIMENSIONS: H x W x D</b>						
<input type="checkbox"/> 6.10es over 6.10es	66-3/4" x 44" x 36-5/8" (1693 x 1115 x 930mm)	<b>EXTERIOR:</b> 35-3/16" x 43-7/8" x 34-1/16" (893mm x 1114mm x 864mm)						
<input type="checkbox"/> 6.10es over 10.10es	73-1/8" x 44" x 36-5/8" (1857 x 1115 x 930mm)	<b>EXTERIOR WITH RECESSED DOOR:</b> 35-3/16" x 47-7/8" x 34-1/16" (893mm x 1216mm x 864mm)						
<input type="checkbox"/> 6.10es over 7.14es	67" x 44" x 43" (1701 x 1115 x 1090mm)	<b>INTERIOR:</b> 17-3/4" x 23-1/2" x 21-1/16" (450mm x 597mm x 535mm)						
<input type="checkbox"/> 6.10es over 10.18es	72-3/4" x 44" x 43" (1845 x 1115 x 1090mm)							
<input type="checkbox"/> Mobile option with 5" (127mm) casters will add 2" (51mm) to the overall height								
<input type="checkbox"/> 6.10es over ASC-4E	74" x 44" x 44-1/2" (1878 x 1115 x 1130mm)							
<b>WATER REQUIREMENTS</b>		<b>WATER QUALITY MINIMUM STANDARDS</b>						
<p><b>TWO (2) COLD WATER INLETS - DRINKING QUALITY</b></p> <p><b>ONE (1) TREATED WATER INLET:</b> 3/4" NPT* * Can manifold off of one 3/4" line.</p> <p><b>ONE (1) UNTREATED WATER INLET:</b> 3/4" NPT*</p> <p><b>LINE PRESSURE:</b> 30 to 90 psi 2.8 to 6.2 bar</p> <p><b>WATER DRAIN:</b> 1-1/2" CONNECTION WITH A 2" MINIMUM AIR GAP INSTALLED AS CLOSE TO THE OVEN AS POSSIBLE</p>		<p>USING A WATER SUPPLY NOT MEETING ALTO-SHAAM'S MINIMUM WATER QUALITY STANDARDS WILL VOID THIS WARRANTY. It is the responsibility of the purchaser to ensure that incoming water supply is compliant with the specifications listed through adequate treatment measures. Installation of the CombiGuard™ Water Filtration System is recommended, but this system may not address all water quality issues present.</p>						
<b>CLEARANCE REQUIREMENTS</b>		<p><b>Contaminant Inlet Water Requirements (untreated water)</b></p> <p>Free Chlorine Less than 0.1 ppm (mg/L)</p> <p>Hardness Less than 3 gpg (52 ppm)</p> <p>Chloride Less than 30 ppm (mg/L)</p> <p>pH 7.0 to 8.5</p> <p>Alkalinity Less than 50 ppm (mg/L)</p> <p>Silica Less than 12 ppm (mg/L)</p> <p>Total Dissolved Solids (tds) Less than 60 ppm</p>						
<p><b>LEFT</b> 6" (152mm) <b>RECOMMENDED SERVICE ACCESS:</b> 18" (457mm)</p> <p>20" (508mm) <b>FROM HEAT PRODUCING EQUIPMENT</b></p> <p><b>RIGHT</b> 4" (102mm) <b>TOP:</b> 20" (508mm) <b>FOR AIR MOVEMENT</b></p> <p><b>BACK</b> 4" (102mm) <b>BOTTOM:</b> 5-1/8" (130mm) <b>FOR LEGS</b></p> <p>COUNTER-TOP INSTALLATIONS MUST MAINTAIN 4" (102mm) MINIMUM CLEARANCE FROM COUNTER SURFACE</p>								
<b>INSTALLATION REQUIREMENTS</b>								
<ul style="list-style-type: none"> <li>Oven must be installed level.</li> <li>Hood installation is required.</li> <li>Water supply shut-off valve and back-flow preventer when required by local code.</li> </ul>								
<b>ELECTRICAL (DEDICATED CIRCUIT REQUIRED)</b>								CombiSmoker®
MODEL	VOLTAGE	PH	HZ	AMPS	kW	AWG	CORD & PLUG	Additional kW
6•10ESi Touch	208 - 240	1*	60	44.0 - 50.0	9.1 - 12.0	AWG 6	no cord or plug	+ .7 kw
	208 - 240	3	60	25.2 - 27.0/ph	9.1 - 11.3	AWG 8	no cord or plug	+ .7 kw
	380 - 415	3	50/60	14.0 - 16.3/ph	9.0 - 11.7	AWG 12	no cord or plug	+ .7 kw
6•10ESi	208 - 240	1*	60	43.4 - 48.7	9.0 - 11.7	AWG 6	no cord or plug	+ .7 kw
	208 - 240	3	60	25.0 - 28.2/ph	9.0 - 11.7	AWG 8	no cord or plug	+ .7 kw
	380 - 415	3	50/60	14.0 - 16.3/ph	9.0 - 11.7	AWG 12	no cord or plug	+ .7 kw

\*ELECTRICAL SERVICE CHARGE APPLIES

<b>WEIGHT</b>		<b>CAPACITY</b>		
NET	285 lb (129 kg)	<p><b>FULL-SIZE PANS:</b></p> <p>20" x 12" x 2-1/2"</p> <p>GN 1/1: 530 x 325 x 65mm</p> <p>GN 2/1: 650 x 530 x 65mm</p>	Six (6)	
SHIP	415 lb (188 kg)		Six (6)	
<p><b>CRATE DIMENSIONS: (L x W x H)</b></p> <p>53" x 45" x 49"</p> <p>(1346 x 1143 x 1245mm)</p>		<p><b>HALF-SIZE SHEET PANS:*</b></p> <p>18" x 13" x 1"</p> <p>ON WIRE SHELVES ONLY</p>	Three (3)	
			Five (5)	
72 lb (33 kg) MAXIMUM				
VOLUME MAXIMUM: 45 quarts (57 liters)				

\*ADDITIONAL WIRE SHELVES REQUIRED FOR MAXIMUM CAPACITY

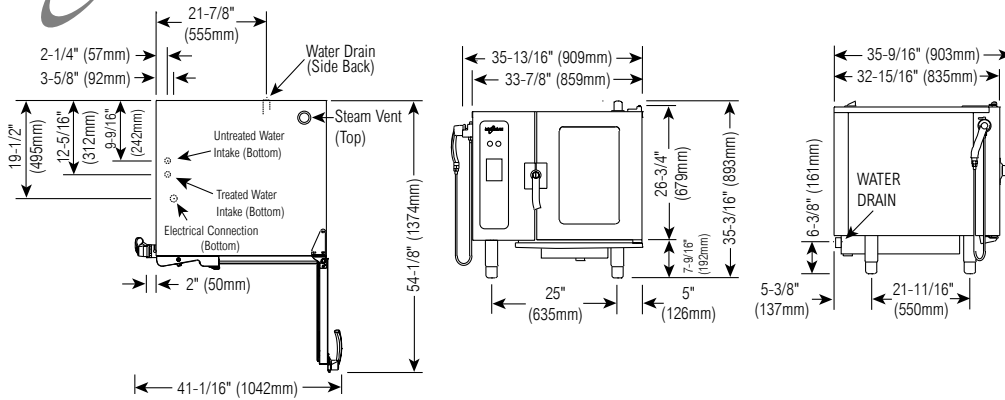

<b>STACKING COMBINATION DIMENSIONS: H x W x D</b>		<b>DIMENSIONS: H x W x D</b>						
<input type="checkbox"/> 6.10esiN over 6.10esiN 67" x 35-13/16" x 38-3/16" (1690 x 909 x 970mm) <input type="checkbox"/> 6.10esiN over 10.10esiN 73-1/8" x 35-13/16" x 38-3/16" (1856 x 909 x 970mm) <input type="checkbox"/> 6.10esiN over 7.14es 67" x 44" x 43" (1701 x 1117 x 1090mm) <input type="checkbox"/> 6.10esiN over 10.18es 73-1/8" x 44" x 43" (1856 x 1117 x 1090mm) <input type="checkbox"/> Mobile option with 5" (127mm) casters will add 2" (51mm) to the overall height <input type="checkbox"/> 6.10esiN over ASC-2E 71" x 35-13/16" x 36" (1803 x 909 x 914mm) <input type="checkbox"/> 6.10esiN over ASC-4E 71" x 35-13/16" x 35-9/16" (1803 x 909 x 903mm) <input type="checkbox"/> 6.10esiN over ASC-4G 73-1/4" x 38" x 44-5/8" (1860 x 966 x 1134mm)		<b>EXTERIOR:</b> 35-3/16" x 35-13/16" x 35-9/16" (893mm x 909mm x 903mm) <b>EXTERIOR WITH RECESSED DOOR:</b> 35-3/16" x 39-13/16" x 35-9/16" (893mm x 1011mm x 903mm) <b>INTERIOR:</b> 17-3/4" x 13-1/4" x 26-1/4" (450mm x 387mm x 665mm)						
<b>WATER REQUIREMENTS</b>		<b>WATER QUALITY MINIMUM STANDARDS</b>						
<b>TWO (2) COLD WATER INLETS - DRINKING QUALITY</b> <b>ONE (1) TREATED WATER INLET:</b> 3/4" NPT* * Can manifold off of one 3/4" line. <b>ONE (1) UNTREATED WATER INLET:</b> 3/4" NPT* <b>LINE PRESSURE:</b> 30 to 90 psi 2.8 to 6.2 bar <b>WATER DRAIN:</b> 1-1/2" CONNECTION WITH A 2" MINIMUM AIR GAP INSTALLED AS CLOSE TO THE OVEN AS POSSIBLE		USING A WATER SUPPLY NOT MEETING ALTO-SHAAM'S MINIMUM WATER QUALITY STANDARDS WILL VOID THIS WARRANTY. It is the responsibility of the purchaser to ensure that incoming water supply is compliant with the specifications listed through adequate treatment measures. Installation of the CombiGuard™ Water Filtration System is recommended, but this system may not address all water quality issues present.						
<b>CLEARANCE REQUIREMENTS</b>		<b>Contaminant Inlet Water Requirements (untreated water)</b>						
<b>LEFT</b> 6" (152mm) <b>RECOMMENDED SERVICE ACCESS:</b> 18" (457mm) 20" (508mm) <b>FROM HEAT PRODUCING EQUIPMENT</b> <b>RIGHT</b> 4" (102mm) <b>TOP:</b> 20" (508mm) <b>FOR AIR MOVEMENT</b> <b>BACK</b> 4" (102mm) <b>BOTTOM:</b> 5-1/8" (130mm) <b>FOR LEGS</b> COUNTER-TOP INSTALLATIONS MUST MAINTAIN 4" (102mm) MINIMUM CLEARANCE FROM COUNTER SURFACE		Free Chlorine Less than 0.1 ppm (mg/L) Hardness Less than 3 gpg (52 ppm) Chloride Less than 30 ppm (mg/L) pH 7.0 to 8.5 Alkalinity Less than 50 ppm (mg/L) Silica Less than 12 ppm (mg/L) Total Dissolved Solids (tds) Less than 60 ppm						
<b>INSTALLATION REQUIREMENTS</b>								
<ul style="list-style-type: none"> <li>• Oven must be installed level.</li> <li>• Hood installation is required.</li> <li>• Water supply shut-off valve and back-flow preventer when required by local code.</li> </ul>								
<b>ELECTRICAL (DEDICATED CIRCUIT REQUIRED)</b>			CombiSmoker®					
MODEL	VOLTAGE	PH	HZ	AMPS	kW	AWG	CORD & PLUG	Additional kW
6•10ESiN Touch	208 - 240	1*	60	44.0 - 50.0	9.1 - 12.0	AWG 6	no cord or plug	+ .7 kw
	208 - 240	3	60	25.2 - 27.0/ph	9.1 - 11.3	AWG 8	no cord or plug	+ .7 kw
	380 - 415	3	50/60	14.0 - 16.3/ph	9.0 - 11.7	AWG 12	no cord or plug	+ .7 kw
6•10ESiN	208 - 240	1*	60	43.4 - 48.7	9.0 - 11.7	AWG 6	no cord or plug	+ .7 kw
	208 - 240	3	60	25.0 - 28.2/ph	9.0 - 11.7	AWG 8	no cord or plug	+ .7 kw
	380 - 415	3	50/60	14.0 - 16.3/ph	9.0 - 11.7	AWG 12	no cord or plug	+ .7 kw

\*ELECTRICAL SERVICE CHARGE APPLIES

<b>WEIGHT</b>		<b>CAPACITY</b>		
NET	285 lb (129 kg)	FULL-SIZE PANS:	20" x 12" x 2-1/2"	Six (6)
SHIP	415 lb (188 kg)		GN 1/1:	530 x 325 x 65mm
CRATE DIMENSIONS: (L x W x H)		HALF-SIZE SHEET PANS:*	18" x 13" x 1"	Six (6)
53" x 45" x 49"		ON WIRE SHELVES ONLY		
(1346 x 1143 x 1245mm)		72 lb (33 kg) MAXIMUM		
VOLUME MAXIMUM: 45 quarts (57 liters)				

\*ADDITIONAL WIRE SHELVES REQUIRED FOR MAXIMUM CAPACITY

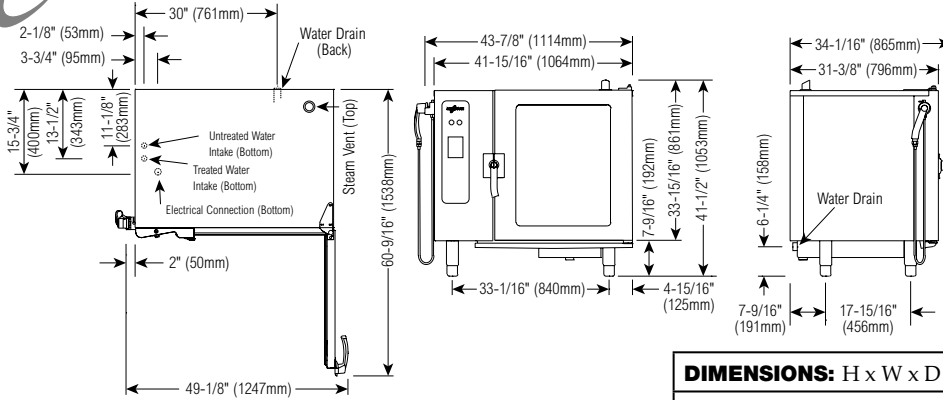

<b>DIMENSIONS:</b> H x W x D
<b>EXTERIOR:</b> 41-1/2" x 43-7/8" x 34-1/16" (1053mm x 1114mm x 865mm)
<b>EXTERIOR WITH RECESSED DOOR:</b> 41-1/2" x 47-7/8" x 34-1/16" (1053mm x 1216mm x 865mm)
<b>INTERIOR:</b> 27" x 23-1/2" x 21-1/16" (685mm x 597mm x 535mm)

<b>WATER REQUIREMENTS</b>	<b>WATER QUALITY MINIMUM STANDARDS</b>
<p><b>TWO (2) COLD WATER INLETS - DRINKING QUALITY</b></p> <p><b>ONE (1) TREATED WATER INLET:</b> 3/4" NPT* * Can manifold off of one 3/4" line.</p> <p><b>ONE (1) UNTREATED WATER INLET:</b> 3/4" NPT*</p> <p><b>LINE PRESSURE:</b> 30 to 90 psi 2.8 to 6.2 bar</p> <p><b>WATER DRAIN:</b> 1-1/2" CONNECTION WITH A 2" MINIMUM AIR GAP INSTALLED AS CLOSE TO THE OVEN AS POSSIBLE</p>	<p>USING A WATER SUPPLY NOT MEETING ALTO-SHAAM'S MINIMUM WATER QUALITY STANDARDS WILL VOID THIS WARRANTY. It is the responsibility of the purchaser to ensure that incoming water supply is compliant with the specifications listed through adequate treatment measures. Installation of the CombiGuard™ Water Filtration System is recommended, but this system may not address all water quality issues present.</p>
<b>CLEARANCE REQUIREMENTS</b>	<p><b>Contaminant Inlet Water Requirements (untreated water)</b></p> <p>Free Chlorine Less than 0.1 ppm (mg/L)</p> <p>Hardness Less than 3 gpg (52 ppm)</p> <p>Chloride Less than 30 ppm (mg/L)</p> <p>pH 7.0 to 8.5</p> <p>Alkalinity Less than 50 ppm (mg/L)</p> <p>Silica Less than 12 ppm (mg/L)</p> <p>Total Dissolved Solids (tds) Less than 60 ppm</p>
<p><b>LEFT</b> 6" (152mm) <b>RECOMMENDED SERVICE ACCESS:</b> 18" (457mm) 20" (508mm) <b>FROM HEAT PRODUCING EQUIPMENT</b></p> <p><b>RIGHT</b> 4" (102mm) <b>TOP:</b> 20" (508mm) <b>FOR AIR MOVEMENT</b></p> <p><b>BACK</b> 4" (102mm) <b>BOTTOM:</b> 5-1/8" (130mm) <b>FOR LEGS</b></p> <p>COUNTER-TOP INSTALLATIONS MUST MAINTAIN 4" (102mm) MINIMUM CLEARANCE FROM COUNTER SURFACE</p>	

<b>INSTALLATION REQUIREMENTS</b>
<ul style="list-style-type: none"> <li>Oven must be installed level.</li> <li>Hood installation is required.</li> <li>Water supply shut-off valve and back-flow preventer when required by local code.</li> </ul>

<b>ELECTRICAL (DEDICATED CIRCUIT REQUIRED)</b>							
MODEL	VOLTAGE	PH	HZ	AMPS	kW	AWG	CORD & PLUG
10•10ES Touch	208 - 240	1*	60	70.0 - 79.2	14.5 - 19.0	AWG 3	no cord or plug
	208 - 240	3	60	40.2 - 45.7/ph	14.5 - 19.0	AWG 6	no cord or plug
	380 - 415	3	50/60	22.1 - 26.5/ph	14.5 - 19.0	AWG 10	no cord or plug
	440 - 480	3*	60	19.0 - 22.8/ph	14.4 - 19.0	AWG 8	no cord or plug
10•10ES	208 - 240	1*	60	67.0 - 77.0	14.5 - 19.0	AWG 3	no cord or plug
	208 - 240	3	60	38.5 - 44.0/ph	13.9 - 18.4	AWG 6	no cord or plug
	380 - 415	3	50/60	21.5 - 25.6/ph	13.9 - 19.0	AWG 10	no cord or plug
	440 - 480	3*	60	20.0 - 22.0/ph	15.4 - 18.4	AWG 8	no cord or plug

\*ELECTRICAL SERVICE CHARGE APPLIES

<b>WEIGHT</b>	<b>CAPACITY</b>
NET 385 lb (175 kg)	FULL-SIZE PANS:
SHIP 525 lb (238 kg)	GN 1/1: 20" x 12" x 2-1/2" Ten (10)
CRATE DIMENSIONS: (L x W x H) 53" x 45" x 49" (1346 x 1143 x 1245mm)	GN 2/1: 530 x 325 x 65mm Ten (10)
	HALF-SIZE SHEET PANS:* 650 x 530 x 65mm Five (5)
	18" x 13" x 1" Ten (10)
	ON WIRE SHELVES ONLY
	120 lb (54 kg) MAXIMUM
	VOLUME MAXIMUM: 75 quarts (95 liters)

\*ADDITIONAL WIRE SHELVES REQUIRED FOR MAXIMUM CAPACITY

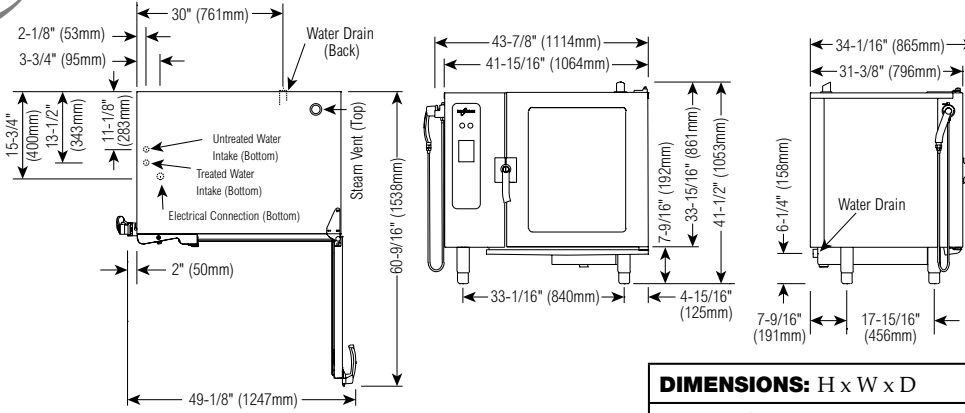

<b>DIMENSIONS:</b> H x W x D
<b>EXTERIOR:</b> 41-1/2" x 43-7/8" x 34-1/16" (1053mm x 1114mm x 865mm)
<b>EXTERIOR WITH RECESSED DOOR:</b> 41-1/2" x 47-7/8" x 34-1/16" (1053mm x 1216mm x 865mm)
<b>INTERIOR:</b> 27" x 23-1/2" x 21-1/16" (685mm x 597mm x 535mm)

<b>WATER REQUIREMENTS</b>	<b>WATER QUALITY MINIMUM STANDARDS</b>
<p><b>TWO (2) COLD WATER INLETS - DRINKING QUALITY</b></p> <p>ONE (1) TREATED WATER INLET: 3/4" NPT* * Can manifold off of one 3/4" line.</p> <p>ONE (1) UNTREATED WATER INLET: 3/4" NPT*</p> <p>LINE PRESSURE: 30 to 90 psi 2.8 to 6.2 bar</p> <p><b>WATER DRAIN:</b> 1-1/2" CONNECTION WITH A 2" MINIMUM AIR GAP INSTALLED AS CLOSE TO THE OVEN AS POSSIBLE</p>	<p>USING A WATER SUPPLY NOT MEETING ALTO-SHAAM'S MINIMUM WATER QUALITY STANDARDS WILL VOID THIS WARRANTY.</p> <p>It is the responsibility of the purchaser to ensure that incoming water supply is compliant with the specifications listed through adequate treatment measures. Installation of the CombiGuard™ Water Filtration System is recommended, but this system may not address all water quality issues present.</p>
<b>CLEARANCE REQUIREMENTS</b>	<p><b>Contaminant Inlet Water Requirements (untreated water)</b></p> <p>Free Chlorine Less than 0.1 ppm (mg/L)</p> <p>Hardness Less than 3 gpg (52 ppm)</p> <p>Chloride Less than 30 ppm (mg/L)</p> <p>pH 7.0 to 8.5</p> <p>Alkalinity Less than 50 ppm (mg/L)</p> <p>Silica Less than 12 ppm (mg/L)</p> <p>Total Dissolved Solids (tds) Less than 60 ppm</p>
<p><b>LEFT</b> 6" (152mm) <b>RECOMMENDED SERVICE ACCESS:</b> 18" (457mm) 20" (508mm) <b>FROM HEAT PRODUCING EQUIPMENT</b></p> <p><b>RIGHT</b> 4" (102mm) <b>TOP:</b> 20" (508mm) <b>FOR AIR MOVEMENT</b></p> <p><b>BACK</b> 4" (102mm) <b>BOTTOM:</b> 5-1/8" (130mm) <b>FOR LEGS</b></p> <p>COUNTER-TOP INSTALLATIONS MUST MAINTAIN 4" (102mm) MINIMUM CLEARANCE FROM COUNTER SURFACE</p>	

<b>INSTALLATION REQUIREMENTS</b>
<ul style="list-style-type: none"> <li>Oven must be installed level.</li> <li>Hood installation is required.</li> <li>Water supply shut-off valve and back-flow preventer when required by local code.</li> </ul>

<b>ELECTRICAL (DEDICATED CIRCUIT REQUIRED)</b>								CombiSmoker®
MODEL	VOLTAGE	PH	HZ	AMPS	kW	AWG	CORD & PLUG	Additional kW
10•10ESi Touch	208 - 240	1*	60	70.0 - 79.2	14.5 - 19.0	AWG 3	no cord or plug	+ .7 kw
	208 - 240	3	60	40.3 - 46.0/ph	14.5 - 19.0	AWG 6	no cord or plug	+ .7 kw
	380 - 415	3	50/60	22.0 - 26.3/ph	14.4 - 18.9	AWG 10	no cord or plug	+ .7 kw
	440 - 480	3*	60	19.0 - 22.8/ph	14.4 - 19.0	AWG 8	no cord or plug	+ .7 kw
10•10ESi	208 - 240	1*	60	69.2 - 79.0	14.4 - 18.9	AWG 3	no cord or plug	+ .7 kw
	208 - 240	3	60	40.0 - 45.5/ph	14.4 - 18.9	AWG 6	no cord or plug	+ .7 kw
	380 - 415	3	50/60	22.0 - 26.3/ph	14.4 - 18.9	AWG 10	no cord or plug	+ .7 kw
	440 - 480	3*	60	21.0 - 23.0/ph	15.9 - 18.9	AWG 8	no cord or plug	+ .7 kw

\*ELECTRICAL SERVICE CHARGE APPLIES

<b>WEIGHT</b>		<b>CAPACITY</b>			
NET	385 lb (175 kg)	FULL-SIZE PANS:	20" x 12" x 2-1/2"	Ten (10)	Eight (8)
SHIP	525 lb (238 kg)		GN 1/1:	530 x 325 x 65mm	Ten (10)
CRATED DIMENSIONS: (L x W x H) 53" x 45" x 49" (1346 x 1143 x 1245mm)		GN 2/1:	650 x 530 x 65mm	Five (5)	Four (4)
		HALF-SIZE SHEET PANS:*	18" x 13" x 1"	Ten (10)	Nine (9)
		ON WIRE SHELVES ONLY			
		120 lb (54 kg) MAXIMUM			
		VOLUME MAXIMUM: 75 quarts (95 liters)			

\*ADDITIONAL WIRE SHELVES REQUIRED FOR MAXIMUM CAPACITY

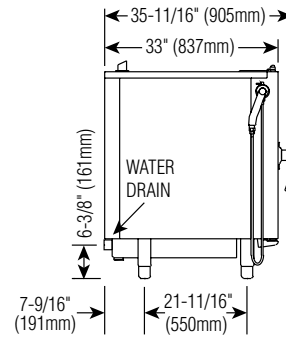
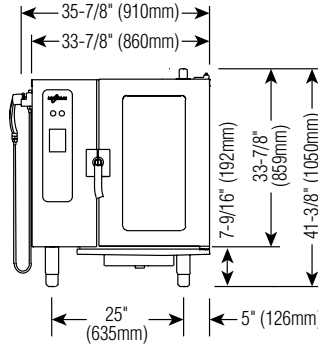
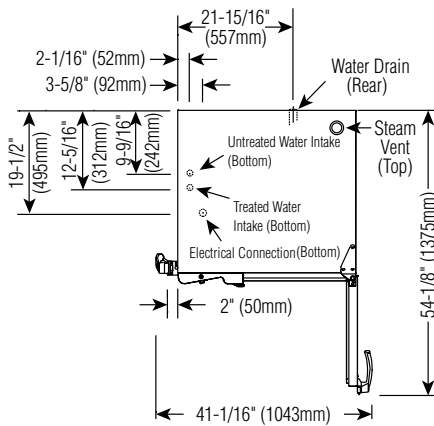

<b>DIMENSIONS:</b> H x W x D
<b>EXTERIOR:</b> 41-3/8" x 35-7/8" x 35-11/16" (1050mm x 910mm x 905mm)
<b>EXTERIOR WITH RECESSED DOOR:</b> 41-3/8" x 39-7/8" x 35-11/16" (1050mm x 1012mm x 905mm)
<b>INTERIOR:</b> 27" x 13-1/4" x 26-1/4" (685mm x 387mm x 665mm)

<b>WATER REQUIREMENTS</b>	<b>WATER QUALITY MINIMUM STANDARDS</b>
<p><b>TWO (2) COLD WATER INLETS - DRINKING QUALITY</b></p> <p><b>ONE (1) TREATED WATER INLET:</b> 3/4" NPT* * Can manifold off of one 3/4" line.</p> <p><b>ONE (1) UNTREATED WATER INLET:</b> 3/4" NPT*</p> <p><b>LINE PRESSURE:</b> 30 to 90 psi 2.8 to 6.2 bar</p> <p><b>WATER DRAIN:</b> 1-1/2" CONNECTION WITH A 2" MINIMUM AIR GAP INSTALLED AS CLOSE TO THE OVEN AS POSSIBLE</p>	<p>USING A WATER SUPPLY NOT MEETING ALTO-SHAAM'S MINIMUM WATER QUALITY STANDARDS WILL VOID THIS WARRANTY.</p> <p>It is the responsibility of the purchaser to ensure that incoming water supply is compliant with the specifications listed through adequate treatment measures. Installation of the CombiGuard™ Water Filtration System is recommended, but this system may not address all water quality issues present.</p>
<b>CLEARANCE REQUIREMENTS</b>	<p><b>Contaminant Inlet Water Requirements (untreated water)</b></p> <p>Free Chlorine Less than 0.1 ppm (mg/L)</p> <p>Hardness Less than 3 gpg (52 ppm)</p> <p>Chloride Less than 30 ppm (mg/L)</p> <p>pH 7.0 to 8.5</p> <p>Alkalinity Less than 50 ppm (mg/L)</p> <p>Silica Less than 12 ppm (mg/L)</p> <p>Total Dissolved Solids (tds) Less than 60 ppm</p>
<p><b>LEFT</b> 6" (152mm) <b>RECOMMENDED SERVICE ACCESS:</b> 18" (457mm) 20" (508mm) <b>FROM HEAT PRODUCING EQUIPMENT</b></p> <p><b>RIGHT</b> 4" (102mm) <b>TOP:</b> 20" (508mm) <b>FOR AIR MOVEMENT</b></p> <p><b>BACK</b> 4" (102mm) <b>BOTTOM:</b> 5-1/8" (130mm) <b>FOR LEGS</b></p> <p>COUNTER-TOP INSTALLATIONS MUST MAINTAIN 4" (102mm) MINIMUM CLEARANCE FROM COUNTER SURFACE</p>	

<b>INSTALLATION REQUIREMENTS</b>
<ul style="list-style-type: none"> <li>Oven must be installed level.</li> <li>Water supply shut-off valve and back-flow preventer when required by local code.</li> <li>Hood installation is required.</li> </ul>

ELECTRICAL (DEDICATED CIRCUIT REQUIRED)								CombiSmoker®
MODEL	VOLTAGE	PH	HZ	AMPS	kW	AWG	CORD & PLUG	Additional kW
10•10ESiN Touch	208 – 240	1*	60	70.0 - 79.2	14.5 - 19.0	AWG 3	no cord or plug	+ .7 kw
	208 – 240	3	60	40.3 - 46.0/ph	14.5 - 19.0	AWG 6	no cord or plug	+ .7 kw
	380 – 415	3	50/60	22.0 - 26.3/ph	14.4 - 18.9	AWG 10	no cord or plug	+ .7 kw
	440 – 480	3*	60	19.0 - 22.8/ph	14.4 - 19.0	AWG 8	no cord or plug	+ .7 kw
10•10ESiN	208 – 240	1*	60	69.2 - 79.0	14.4 - 18.9	AWG 3	no cord or plug	+ .7 kw
	208 – 240	3	60	40.0 - 45.5/ph	14.4 - 18.9	AWG 6	no cord or plug	+ .7 kw
	380 – 415	3	50/60	22.0 - 26.3/ph	14.4 - 18.9	AWG 10	no cord or plug	+ .7 kw
	440 – 480	3*	60	21.0 - 23.0/ph	15.9 - 18.9	AWG 8	no cord or plug	+ .7 kw

\*ELECTRICAL SERVICE CHARGE APPLIES

WEIGHT		CAPACITY			
NET	385 lb (175 kg)	FULL-SIZE PANS: GN 1/1:	20" x 12" x 2-1/2" 530 x 325 x 65mm	Ten (10)	Eight (8)
SHIP	501 lb (227 kg)			Ten (10)	Eight (8)
CRATE DIMENSIONS: (L x W x H) 56" x 45" x 51" (1422 x 1143 x 1295mm)		HALF-SIZE SHEET PANS:*	18" x 13" x 1" ON WIRE SHELVES ONLY	Ten (10)	Nine (9)
120 lb (54 kg) MAXIMUM					
VOLUME MAXIMUM: 75 quarts (95 liters)					

\*ADDITIONAL WIRE SHELVES REQUIRED FOR MAXIMUM CAPACITY

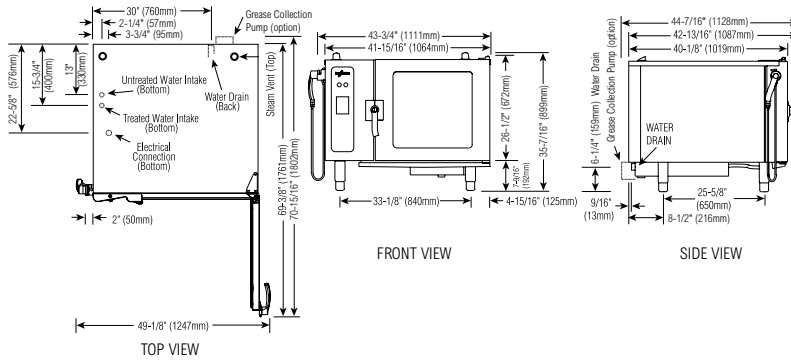

<b>STACKING COMBINATION DIMENSIONS: H x W x D</b>				<b>DIMENSIONS: H x W x D</b>			
<input type="checkbox"/> 6.10ES over 7.14ES	67" x 43-7/8" x 42-15/16"	(1701 x 1114 x 1090mm)		<b>EXTERIOR:</b> 35-7/16" x 43-3/4" x 42-13/16" (899mm x 1111mm x 1087mm)			
<input type="checkbox"/> 6.10esiN over 7.14ES	67" x 44" x 43"	(1701 x 1117 x 1090mm)		<b>EXTERIOR WITH RECESSED DOOR:</b> 35-7/16" x 47-3/4" x 42-13/16" (899mm x 1213mm x 1087mm)			
<input type="checkbox"/> 7.14ES over 7.14ES	67" x 43-7/8" x 45-1/4"	(1701 x 1114 x 1150mm)		<b>INTERIOR:</b> 20-5/16" x 23-1/2" x 28-7/8" (515mm x 596mm x 722mm)			
<input type="checkbox"/> 7.14ES over 10.18ES	73-1/8" x 43-7/8" x 45-3/8"	(1857 x 1114 x 1151mm)					
<input type="checkbox"/> 7.14ES over ASC-4E	73-5/8" x 41-7/8" x 46-9/16"	(1869 x 1064 x 1182mm)					
<input type="checkbox"/> Mobile option with 5" (127mm) casters will add 2" (51mm) to the overall height.							
<b>WATER REQUIREMENTS</b>				<b>WATER QUALITY MINIMUM STANDARDS</b>			
<p><b>TWO (2) COLD WATER INLETS - DRINKING QUALITY</b></p> <p><b>ONE (1) TREATED WATER INLET:</b> 3/4" NPT* * Can manifold off of one (1) TREATED WATER INLET: 3/4" NPT* one 3/4" line.</p> <p><b>LINE PRESSURE:</b> 30 to 90 psi 2.8 to 6.2 bar</p> <p><b>WATER DRAIN:</b> 1-1/2" CONNECTION WITH A 2" MINIMUM AIR GAP INSTALLED AS CLOSE TO THE OVEN AS POSSIBLE</p>				<p>USING A WATER SUPPLY NOT MEETING ALTO-SHAAM'S MINIMUM WATER QUALITY STANDARDS WILL VOID THIS WARRANTY.</p> <p>It is the responsibility of the purchaser to ensure that incoming water supply is compliant with the specifications listed through adequate treatment measures. Installation of the CombiGuard™ Water Filtration System is recommended, but this system may not address all water quality issues present.</p>			
<b>CLEARANCE REQUIREMENTS</b>				<p><b>Contaminant Inlet Water Requirements (untreated water)</b></p> <p>Free Chlorine Less than 0.1 ppm (mg/L)</p> <p>Hardness Less than 3 gpg (52 ppm)</p> <p>Chloride Less than 30 ppm (mg/L)</p> <p>pH 7.0 to 8.5</p> <p>Alkalinity Less than 50 ppm (mg/L)</p> <p>Silica Less than 12 ppm (mg/L)</p> <p>Total Dissolved Solids (tds) Less than 60 ppm</p>			
<p><b>LEFT</b> 6" (152mm) <b>RECOMMENDED SERVICE ACCESS:</b> 18" (457mm)</p> <p>20" (508mm) <b>FROM HEAT PRODUCING EQUIPMENT</b></p> <p><b>RIGHT</b> 4" (102mm) <b>TOP:</b> 20" (508mm) <b>FOR AIR MOVEMENT</b></p> <p><b>BACK</b> 4" (102mm) <b>BOTTOM:</b> 5-1/8" (130mm) <b>FOR LEGS</b></p> <p>COUNTER-TOP INSTALLATIONS MUST MAINTAIN 4" (102mm) MINIMUM CLEARANCE FROM COUNTER SURFACE</p>							
<b>INSTALLATION REQUIREMENTS</b>							
<ul style="list-style-type: none"> <li>Oven must be installed level.</li> <li>Water supply shut-off valve and back-flow preventer when required by local code.</li> </ul>				<ul style="list-style-type: none"> <li>Hood installation is required.</li> </ul>			
<b>ELECTRICAL (DEDICATED CIRCUIT REQUIRED)</b>							
MODEL	VOLTAGE	PH	HZ	AMPS	kW	AWG	CORD & PLUG
7•14ES Touch	208 – 240	1*	60	70.0 - 79.2	14.5 - 19.0	AWG 3	no cord or plug
	208 – 240	3	60	40.2 - 45.7/ph	14.5 - 19.0	AWG 6	no cord or plug
	380 – 415	3	50/60	22.1 - 26.5/ph	14.5 - 19.0	AWG 10	no cord or plug
	440 – 480	3*	60	19.0 - 22.8/ph	14.4 - 19.0	AWG 8	no cord or plug
7•14ES	208 – 240	1*	60	67.0 - 77.0	13.9 - 18.4	AWG 3	no cord or plug
	208 – 240	3	60	38.5 - 44.0/ph	13.9 - 18.4	AWG 6	no cord or plug
	380 – 415	3	50/60	21.5 - 25.6/ph	13.9 - 18.4	AWG 10	no cord or plug
	440 – 480	3*	60	20.0 - 22.0/ph	15.4 - 18.4	AWG 8	no cord or plug

\*ELECTRICAL SERVICE CHARGE APPLIES

WEIGHT		CAPACITY	
NET	405 lb (184 kg)	FULL-SIZE PANS:	20" x 12" x 2-1/2"
SHIP	545 lb (247 kg)	GN 1/1:	530 x 325 x 65mm
CRATE DIMENSIONS: (L x W x H)		GN 2/1:	650 x 530 x 65mm
56" x 45" x 51"		FULL-SIZE SHEET PANS:*	18" x 26" x 1"
(1422 x 1143 x 1295mm)		ON WIRE SHELVES ONLY	
168 lb (76 kg) MAXIMUM			
VOLUME MAXIMUM: 105 quarts (133 liters)			

\*ADDITIONAL WIRE SHELVES REQUIRED FOR MAXIMUM CAPACITY



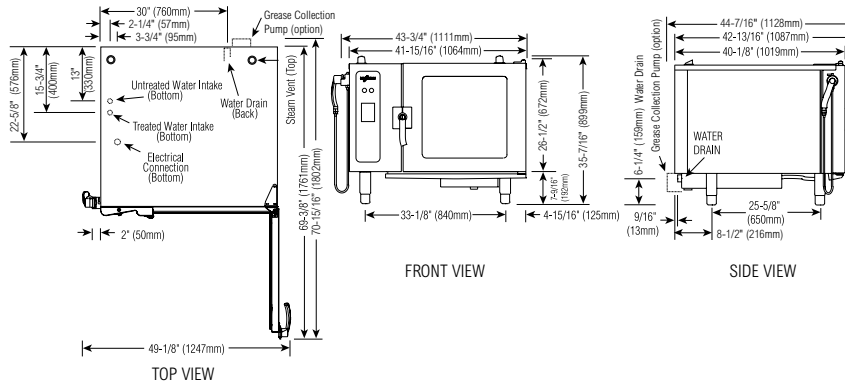

<b>STACKING COMBINATION DIMENSIONS: H x W x D</b>		<b>DIMENSIONS: H x W x D</b>						
<input type="checkbox"/> 6.10ES over 7.14ES	67" x 43-7/8" x 42-15/16" (1701 x 1114 x 1090mm)	<b>EXTERIOR:</b> 35-7/16" x 43-3/4" x 42-13/16" (899mm x 1111mm x 1087mm)						
<input type="checkbox"/> 6.10esiN over 7.14es	67" x 44" x 43" (1701 x 1117 x 1090mm)	<b>EXTERIOR WITH RECESSED DOOR:</b> 35-7/16" x 47-3/4" x 42-13/16" (899mm x 1213mm x 1087mm)						
<input type="checkbox"/> 7.14es over 7.14es	67" x 43-7/8" x 45-1/4" (1701 x 1114 x 1150mm)	<b>INTERIOR:</b> 20-5/16" x 23-1/2" x 28-7/8" (515mm x 596mm x 722mm)						
<input type="checkbox"/> 7.14ES over 10.18ES	73-1/8" x 43-7/8" x 45-3/8" (1857 x 1114 x 1151mm)							
<input type="checkbox"/> 7.14ES over ASC-4E	73-5/8" x 41-7/8" x 46-9/16" (1869 x 1064 x 1182mm)							
<input type="checkbox"/> Mobile option with 5" (127mm) casters will add 2" (51mm) to the overall height.								
<b>WATER REQUIREMENTS</b>		<b>WATER QUALITY MINIMUM STANDARDS</b>						
<p><b>TWO (2) COLD WATER INLETS - DRINKING QUALITY</b></p> <p>ONE (1) TREATED WATER INLET: 3/4" NPT* * Can manifold off of one 3/4" line.</p> <p>ONE (1) UNTREATED WATER INLET: 3/4" NPT*</p> <p>LINE PRESSURE: 30 to 90 psi 2.8 to 6.2 bar</p> <p>WATER DRAIN: 1-1/2" CONNECTION WITH A 2" MINIMUM AIR GAP INSTALLED AS CLOSE TO THE OVEN AS POSSIBLE</p>		<p>USING A WATER SUPPLY NOT MEETING ALTO-SHAAM'S MINIMUM WATER QUALITY STANDARDS WILL VOID THIS WARRANTY.</p> <p>It is the responsibility of the purchaser to ensure that incoming water supply is compliant with the specifications listed through adequate treatment measures. Installation of the CombiGuard™ Water Filtration System is recommended, but this system may not address all water quality issues present.</p>						
<b>CLEARANCE REQUIREMENTS</b>								
<b>LEFT</b>	6" (152mm) <b>RECOMMENDED SERVICE ACCESS: 18" (457mm)</b> 20" (508mm) <b>FROM HEAT PRODUCING EQUIPMENT</b>							
<b>RIGHT</b>	4" (102mm) <b>TOP: 20" (508mm) FOR AIR MOVEMENT</b>							
<b>BACK</b>	4" (102mm) <b>BOTTOM: 5-1/8" (130mm) FOR LEGS</b>							
<b>INSTALLATION REQUIREMENTS</b>								
<ul style="list-style-type: none"> <li>Oven must be installed level.</li> <li>Water supply shut-off valve and back-flow preventer when required by local code.</li> </ul>		<ul style="list-style-type: none"> <li>Hood installation is required.</li> </ul>						
<b>ELECTRICAL (DEDICATED CIRCUIT REQUIRED)</b>								CombiSmoker®
MODEL	VOLTAGE	PH	HZ	AMPS	kW	AWG	CORD & PLUG	Additional kW
7•14ESi Touch	208 - 240	1*	60	70.0 - 79.2	14.5 - 19.0	AWG 3	no cord or plug	+ .7 kw
	208 - 240	3	60	40.3 - 46.0/ph	14.5 - 19.0	AWG 6	no cord or plug	+ .7 kw
	380 - 415	3	50/60	22.0 - 26.3/ph	14.4 - 18.9	AWG 10	no cord or plug	+ .7 kw
	440 - 480	3*	60	19.0 - 22.8/ph	14.4 - 19.0	AWG 8	no cord or plug	+ .7 kw
7•14ESi	208 - 240	1*	60	69.2 - 79.0	14.4 - 18.9	AWG 3	no cord or plug	+ .7 kw
	208 - 240	3	60	40.0 - 45.5/ph	14.4 - 18.9	AWG 6	no cord or plug	+ .7 kw
	380 - 415	3	50/60	22.0 - 26.3/ph	14.4 - 18.9	AWG 10	no cord or plug	+ .7 kw
	440 - 480	3*	60	21.0 - 23.0/ph	15.9 - 18.9	AWG 8	no cord or plug	+ .7 kw

\*ELECTRICAL SERVICE CHARGE APPLIES

<b>WEIGHT</b>		<b>CAPACITY</b>	
NET	405 lb (184 kg)	FULL-SIZE PANS:	20" x 12" x 2-1/2"
SHIP	530 lb (240 kg)	GN 1/1:	530 x 325 x 65mm
CRATE DIMENSIONS: (L x W x H)		GN 2/1:	650 x 530 x 65mm
56" x 49" x 45"		FULL-SIZE SHEET PANS:*	18" x 26" x 1"
(1422 x 1245 x 1143mm)		ON WIRE SHELVES ONLY	
168 lb (76 kg) MAXIMUM			
VOLUME MAXIMUM: 105 quarts (133 liters)			

\*ADDITIONAL WIRE SHELVES REQUIRED FOR MAXIMUM CAPACITY

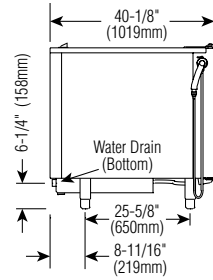
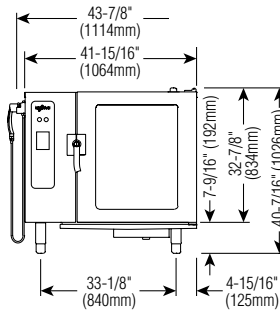
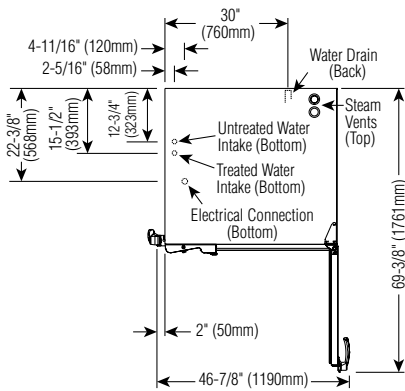

<b>DIMENSIONS:</b> H x W x D
<b>EXTERIOR:</b> 40-7/16" x 43-7/8" x 42-13/16" (1026mm x 1114mm x 1087mm)
<b>EXTERIOR WITH RECESSED DOOR:</b> 40-7/16" x 47-7/8" x 42-13/16" (1026mm x 1216mm x 1087mm)
<b>INTERIOR:</b> 30-3/4" x 23-1/2" x 28-7/16" (781mm x 596mm x 722mm)

<b>WATER REQUIREMENTS</b>
<p><b>TWO (2) COLD WATER INLETS - DRINKING QUALITY</b></p> <p>ONE (1) TREATED WATER INLET: 3/4" NPT* * Can manifold off of one 3/4" line.</p> <p>ONE (1) UNTREATED WATER INLET: 3/4" NPT*</p> <p>LINE PRESSURE: 30 to 90 psi 2.8 to 6.2 bar</p> <p><b>WATER DRAIN:</b> 1-1/2" CONNECTION WITH A 2" MINIMUM AIR GAP INSTALLED AS CLOSE TO THE OVEN AS POSSIBLE</p>

<b>WATER QUALITY MINIMUM STANDARDS</b>
<p>USING A WATER SUPPLY NOT MEETING ALTO-SHAAM'S MINIMUM WATER QUALITY STANDARDS WILL VOID THIS WARRANTY. It is the responsibility of the purchaser to ensure that incoming water supply is compliant with the specifications listed through adequate treatment measures. Installation of the CombiGuard™ Water Filtration System is recommended, but this system may not address all water quality issues present.</p>

<b>CLEARANCE REQUIREMENTS</b>
<p><b>LEFT</b> 6" (152mm) <b>RECOMMENDED SERVICE ACCESS:</b> 18" (457mm) 20" (508mm) <b>FROM HEAT PRODUCING EQUIPMENT</b></p> <p><b>RIGHT</b> 4" (102mm) <b>TOP:</b> 20" (508mm) <b>FOR AIR MOVEMENT</b></p> <p><b>BACK</b> 4" (102mm) <b>BOTTOM:</b> 5-1/8" (130mm) <b>FOR LEGS</b></p> <p>COUNTER-TOP INSTALLATIONS MUST MAINTAIN 4" (102mm) MINIMUM CLEARANCE FROM COUNTER SURFACE</p>

<b>Contaminant Inlet Water Requirements (untreated water)</b>
Free Chlorine Less than 0.1 ppm (mg/L)
Hardness Less than 3 gpg (52 ppm)
Chloride Less than 30 ppm (mg/L)
pH 7.0 to 8.5
Alkalinity Less than 50 ppm (mg/L)
Silica Less than 12 ppm (mg/L)
Total Dissolved Solids (tds) Less than 60 ppm

<b>INSTALLATION REQUIREMENTS</b>
<ul style="list-style-type: none"> <li>Oven must be installed level.</li> <li>Water supply shut-off valve and back-flow preventer when required by local code.</li> <li>Hood installation is required.</li> </ul>

<b>ELECTRICAL (DEDICATED CIRCUIT REQUIRED)</b>							
MODEL	VOLTAGE	PH	HZ	AMPS	kW	AWG	CORD & PLUG
10•18ES Touch	208 - 240	3	60	61.3 - 70.0 / ph	22.6 - 29.8	AWG 2	no cord or plug
	380 - 415	3	50/60	33.5 - 40.7 / ph	22.0 - 29.2	AWG 6	no cord or plug
	440 - 480	3*	60	36.0 - 43.5 / ph	27.8 - 26.7	AWG 6	no cord or plug
10•18ES	208 - 240	3	60	61.3 - 70.0 / ph	22.0 - 29.2	AWG 2	no cord or plug
	380 - 415	3	50/60	33.5 - 40.7 / ph	22.0 - 29.2	AWG 6	no cord or plug
	440 - 480	3*	60	36.0 - 43.5 / ph	27.2 - 36.1	AWG 6	no cord or plug

\*ELECTRICAL SERVICE CHARGE APPLIES

<b>WEIGHT</b>	<b>CAPACITY</b>
NET 455 lb (206 kg)	<p>FULL-SIZE PANS:</p> <p>20" x 12" x 2-1/2"</p> <p>GN 1 / 1: 530 x 325 x 65mm</p> <p>GN 2 / 1: 650 x 530 x 65mm</p> <p>FULL-SIZE SHEET PANS:* 18" x 26" x 1"</p> <p>ON WIRE SHELVES ONLY</p>
SHIP 585 lb (265 kg)	
CRATE DIMENSIONS: (L x W x H) 56" x 45" x 51" (1422 x 1143 x 1295mm)	<p>Twenty (20)</p> <p>Twenty (20)</p> <p>Ten (10)</p> <p>Ten (10)</p>
240 lb (109 kg) MAXIMUM	
VOLUME MAXIMUM: 150 quarts (190 liters)	

\*ADDITIONAL WIRE SHELVES REQUIRED FOR MAXIMUM CAPACITY

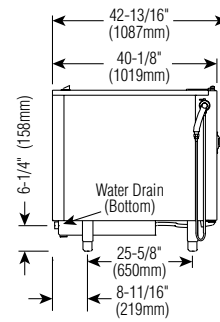
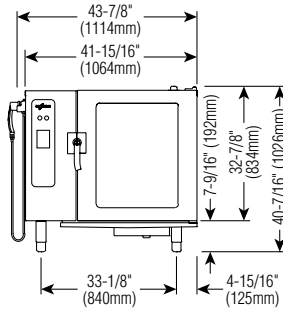
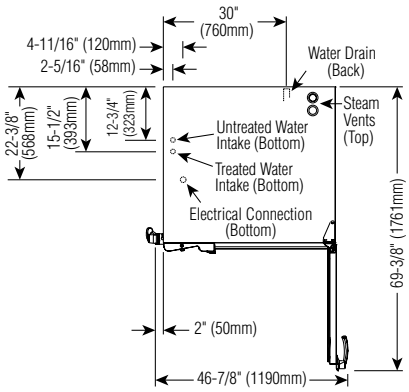

<b>DIMENSIONS:</b> H x W x D
<b>EXTERIOR:</b> 40-7/16" x 43-7/8" x 42-13/16" (1026mm x 1114mm x 1087mm)
<b>EXTERIOR WITH RECESSED DOOR:</b> 40-7/16" x 47-7/8" x 42-13/16" (1026mm x 1216mm x 1087mm)
<b>INTERIOR:</b> 30-3/4" x 23-1/2" x 28-7/16" (781mm x 596mm x 722mm)

<b>WATER REQUIREMENTS</b>	<b>WATER QUALITY MINIMUM STANDARDS</b>
<p><b>TWO (2) COLD WATER INLETS - DRINKING QUALITY</b></p> <p>ONE (1) TREATED WATER INLET: 3/4" NPT* * Can manifold off of one 3/4" line.</p> <p>ONE (1) UNTREATED WATER INLET: 3/4" NPT*</p> <p>LINE PRESSURE: 30 to 90 psi 2.8 to 6.2 bar</p> <p><b>WATER DRAIN:</b> 1-1/2" CONNECTION WITH A 2" MINIMUM AIR GAP INSTALLED AS CLOSE TO THE OVEN AS POSSIBLE</p>	<p>USING A WATER SUPPLY NOT MEETING ALTO-SHAAM'S MINIMUM WATER QUALITY STANDARDS WILL VOID THIS WARRANTY.</p> <p>It is the responsibility of the purchaser to ensure that incoming water supply is compliant with the specifications listed through adequate treatment measures. Installation of the CombiGuard™ Water Filtration System is recommended, but this system may not address all water quality issues present.</p>
<b>CLEARANCE REQUIREMENTS</b>	<p><b>Contaminant Inlet Water Requirements (untreated water)</b></p> <p>Free Chlorine Less than 0.1 ppm (mg/L)</p> <p>Hardness Less than 3 gpg (52 ppm)</p> <p>Chloride Less than 30 ppm (mg/L)</p> <p>pH 7.0 to 8.5</p> <p>Alkalinity Less than 50 ppm (mg/L)</p> <p>Silica Less than 12 ppm (mg/L)</p> <p>Total Dissolved Solids (tds) Less than 60 ppm</p>
<p><b>LEFT</b> 6" (152mm) <b>RECOMMENDED SERVICE ACCESS:</b> 18" (457mm) 20" (508mm) <b>FROM HEAT PRODUCING EQUIPMENT</b></p> <p><b>RIGHT</b> 4" (102mm) <b>TOP:</b> 20" (508mm) <b>FOR AIR MOVEMENT</b></p> <p><b>BACK</b> 4" (102mm) <b>BOTTOM:</b> 5-1/8" (130mm) <b>FOR LEGS</b></p> <p>COUNTER-TOP INSTALLATIONS MUST MAINTAIN 4" (102mm) MINIMUM CLEARANCE FROM COUNTER SURFACE</p>	

<b>INSTALLATION REQUIREMENTS</b>
<ul style="list-style-type: none"> <li>Oven must be installed level.</li> <li>Hood installation is required.</li> <li>Water supply shut-off valve and back-flow preventer when required by local code.</li> </ul>

ELECTRICAL (DEDICATED CIRCUIT REQUIRED)								CombiSmoker®
MODEL	VOLTAGE	PH	HZ	AMPS	kW	AWG	CORD & PLUG	Additional kW
10•18ESi Touch	208 – 240	3	60	61.1 - 70.3/ph	22.6 - 29.8	AWG 2	no cord or plug	+ .7 kw
	380 – 415	3	50/60	33.5 - 40.7/ph	22.6 - 29.8	AWG 8	no cord or plug	+ .7 kw
	440 – 480	3*	60	35.7 - 43.5/ph	27.8 - 36.7	AWG 8	no cord or plug	+ .7 kw
10•18ESi	208 – 240	3	60	61.1 - 70.3/ph	22.5 - 29.7	AWG 2	no cord or plug	+ .7 kw
	380 – 415	3	50/60	33.5 - 40.7/ph	22.5 - 29.7	AWG 8	no cord or plug	+ .7 kw
	440 – 480	3*	60	35.7 - 43.5/ph	27.7 - 36.6	AWG 8	no cord or plug	+ .7 kw

\*ELECTRICAL SERVICE CHARGE APPLIES

WEIGHT		CAPACITY			
NET	455 lb (206 kg)	FULL-SIZE PANS:	20" x 12" x 2-1/2"	Twenty (20)	Eighteen (18)
SHIP	585 lb (265 kg)		GN 1/1:	530 x 325 x 65mm	Twenty (20)
CRATE DIMENSIONS: (L x W x H) 56" x 45" x 51" (1422 x 1143 x 1295mm)		GN 2/1:	650 x 530 x 65mm	Ten (10)	Eight (8)
		FULL-SIZE SHEET PANS:* ON WIRE SHELVES ONLY	18" x 26" x 1"	Ten (10)	Nine (9)
240 lb (109 kg) MAXIMUM					
VOLUME MAXIMUM: 150 quarts (190 liters)					

\*ADDITIONAL WIRE SHELVES REQUIRED FOR MAXIMUM CAPACITY

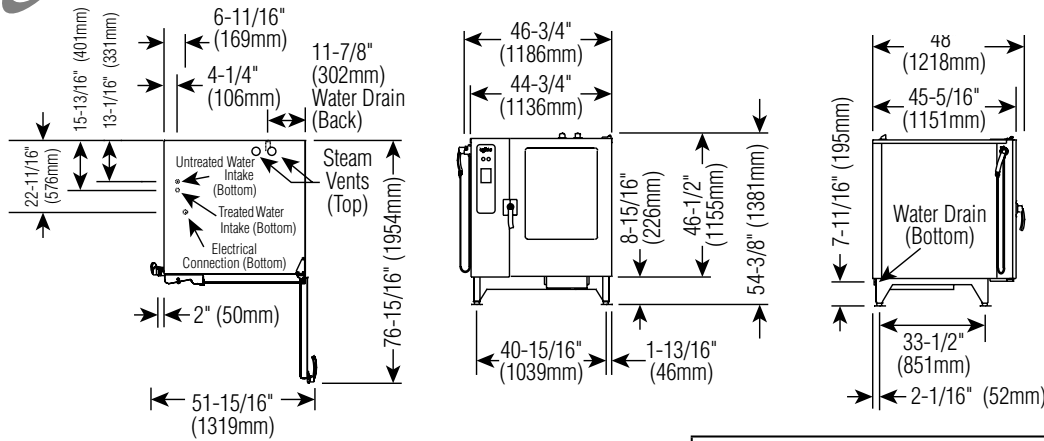

<b>DIMENSIONS:</b> H x W x D
<b>EXTERIOR:</b> 54-3/8" x 46-3/4" x 48" (1381mm x 1186mm x 1218mm)
<b>EXTERIOR WITH RECESSED DOOR:</b> 54-3/8" x 50-3/4" x 48" (1381mm x 1288mm x 1218mm)
<b>INTERIOR:</b> 38-11/16" x 26-1/4" x 32-11/16" (983mm x 667mm x 830mm)

<b>WATER REQUIREMENTS</b>
<p><b>TWO (2) COLD WATER INLETS - DRINKING QUALITY</b></p> <p>ONE (1) TREATED WATER INLET: 3/4" NPT* * Can manifold off of one 3/4" line.</p> <p>ONE (1) UNTREATED WATER INLET: 3/4" NPT*</p> <p>LINE PRESSURE: 30 to 90 psi 2.8 to 6.2 bar</p> <p>WATER DRAIN: 1-1/2" CONNECTION WITH A 2" MINIMUM AIR GAP INSTALLED AS CLOSE TO THE OVEN AS POSSIBLE</p>

<b>WATER QUALITY MINIMUM STANDARDS</b>																
<p>USING A WATER SUPPLY NOT MEETING ALTO-SHAAM'S MINIMUM WATER QUALITY STANDARDS WILL VOID THIS WARRANTY. It is the responsibility of the purchaser to ensure that incoming water supply is compliant with the specifications listed through adequate treatment measures. Installation of the CombiGuard™ Water Filtration System is recommended, but this system may not address all water quality issues present.</p>																
<table border="1"> <thead> <tr> <th>Contaminant</th> <th>Inlet Water Requirements (untreated water)</th> </tr> </thead> <tbody> <tr> <td>Free Chlorine</td> <td>Less than 0.1 ppm (mg/L)</td> </tr> <tr> <td>Hardness</td> <td>Less than 3 gpg (52 ppm)</td> </tr> <tr> <td>Chloride</td> <td>Less than 30 ppm (mg/L)</td> </tr> <tr> <td>pH</td> <td>7.0 to 8.5</td> </tr> <tr> <td>Alkalinity</td> <td>Less than 50 ppm (mg/L)</td> </tr> <tr> <td>Silica</td> <td>Less than 12 ppm (mg/L)</td> </tr> <tr> <td>Total Dissolved Solids (tds)</td> <td>Less than 60 ppm</td> </tr> </tbody> </table>	Contaminant	Inlet Water Requirements (untreated water)	Free Chlorine	Less than 0.1 ppm (mg/L)	Hardness	Less than 3 gpg (52 ppm)	Chloride	Less than 30 ppm (mg/L)	pH	7.0 to 8.5	Alkalinity	Less than 50 ppm (mg/L)	Silica	Less than 12 ppm (mg/L)	Total Dissolved Solids (tds)	Less than 60 ppm
Contaminant	Inlet Water Requirements (untreated water)															
Free Chlorine	Less than 0.1 ppm (mg/L)															
Hardness	Less than 3 gpg (52 ppm)															
Chloride	Less than 30 ppm (mg/L)															
pH	7.0 to 8.5															
Alkalinity	Less than 50 ppm (mg/L)															
Silica	Less than 12 ppm (mg/L)															
Total Dissolved Solids (tds)	Less than 60 ppm															

<b>CLEARANCE REQUIREMENTS</b>
<p><b>LEFT</b> 6" (152mm) <b>RECOMMENDED SERVICE ACCESS: 18" (457mm)</b></p> <p>20" (508mm) <b>FROM HEAT PRODUCING EQUIPMENT</b></p> <p><b>RIGHT</b> 4" (102mm) <b>TOP: 20" (508mm) FOR AIR MOVEMENT</b></p> <p><b>BACK</b> 4" (102mm) <b>BOTTOM: 5-1/8" (130mm) FOR LEGS</b></p>

<b>INSTALLATION REQUIREMENTS</b>
<ul style="list-style-type: none"> <li>Oven must be installed level.</li> <li>Hood installation is required.</li> <li>Water supply shut-off valve and back-flow preventer when required by local code.</li> </ul>

<b>ELECTRICAL (DEDICATED CIRCUIT REQUIRED)</b>							
MODEL	VOLTAGE	PH	HZ	AMPS	kW	AWG	CORD & PLUG
12•20ES Touch	208 – 240	3	60	75.6 - 87.0/ph	27.7 - 36.6	AWG 2	no cord or plug
	380 – 415	3	50/60	41.4 - 36.1/ph	27.8 - 36.7	AWG 6	no cord or plug
	440 – 480	3*	60	36.0 - 43.5/ph	27.8 - 36.7	AWG 6	no cord or plug
12•20ES	208 – 240	3	60	75.6 - 87.0/ph	27.2 - 36.1	AWG 2	no cord or plug
	380 – 415	3	50/60	41.4 - 36.1/ph	27.2 - 36.1	AWG 6	no cord or plug
	440 – 480	3*	60	36.0 - 43.5/ph	27.2 - 36.1	AWG 6	no cord or plug

\*ELECTRICAL SERVICE CHARGE APPLIES

<b>WEIGHT</b>	<b>CAPACITY</b>
NET 665 lb (302 kg)	FULL-SIZE PANS: 20" x 12" x 2-1/2" Twenty-four (24)
SHIP 750 lb (340 kg)	GN 1/1: 530 x 325 x 65mm Twenty-four (24)
CRATE DIMENSIONS: (L x W x H) 53" x 53" x 87" (1346 x 1346 x 2210mm)	GN 2/1: 650 x 530 x 65mm Twelve (12)
	FULL-SIZE SHEET PANS:* 18" x 26" x 1" Twelve (12)
ON WIRE SHELVES ONLY	
288 lb (131 kg) MAXIMUM	
VOLUME MAXIMUM: 180 quarts (128 liters)	

\*ADDITIONAL WIRE SHELVES REQUIRED FOR MAXIMUM CAPACITY

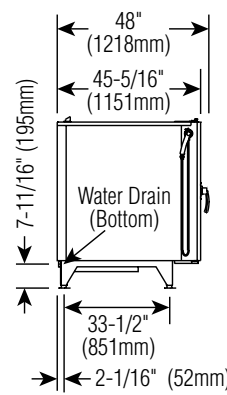
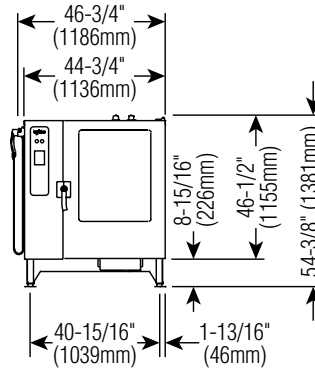
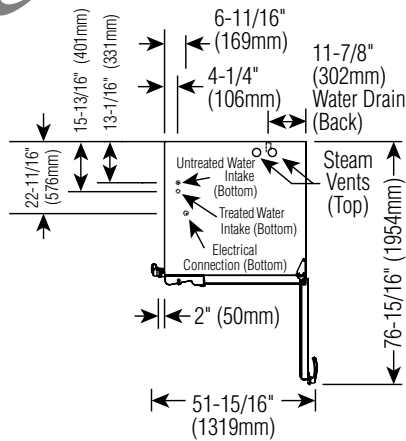

<b>DIMENSIONS:</b> H x W x D
<b>EXTERIOR:</b> 54-3/8" x 46-3/4" x 48" (1381mm x 1186mm x 1218mm)
<b>EXTERIOR WITH RECESSED DOOR:</b> 54-3/8" x 50-3/4" x 48" (1381mm x 1288mm x 1218mm)
<b>INTERIOR:</b> 38-11/16" x 26-1/4" x 32-11/16" (983mm x 667mm x 830mm)

<b>WATER REQUIREMENTS</b>	
TWO (2) COLD WATER INLETS - DRINKING QUALITY	
ONE (1) TREATED WATER INLET:	3/4" NPT* * Can manifold off of one 3/4" line.
ONE (1) UNTREATED WATER INLET:	3/4" NPT*
LINE PRESSURE:	30 to 90 psi 2.8 to 6.2 bar
WATER DRAIN:	1-1/2" CONNECTION WITH A 2" MINIMUM AIR GAP INSTALLED AS CLOSE TO THE OVEN AS POSSIBLE
<b>CLEARANCE REQUIREMENTS</b>	
LEFT	6" (152mm) RECOMMENDED SERVICE ACCESS: 18" (457mm) 20" (508mm) FROM HEAT PRODUCING EQUIPMENT
RIGHT	4" (102mm) TOP: 20" (508mm) FOR AIR MOVEMENT
BACK	4" (102mm) BOTTOM: 5-1/8" (130mm) FOR LEGS

<b>WATER QUALITY MINIMUM STANDARDS</b>	
USING A WATER SUPPLY NOT MEETING ALTO-SHAAM'S MINIMUM WATER QUALITY STANDARDS WILL VOID THIS WARRANTY. It is the responsibility of the purchaser to ensure that incoming water supply is compliant with the specifications listed through adequate treatment measures. Installation of the CombiGuard™ Water Filtration System is recommended, but this system may not address all water quality issues present.	
<b>Contaminant</b>	<b>Inlet Water Requirements (untreated water)</b>
Free Chlorine	Less than 0.1 ppm (mg/L)
Hardness	Less than 3 gpg (52 ppm)
Chloride	Less than 30 ppm (mg/L)
pH	7.0 to 8.5
Alkalinity	Less than 50 ppm (mg/L)
Silica	Less than 12 ppm (mg/L)
Total Dissolved Solids (tds)	Less than 60 ppm

<b>INSTALLATION REQUIREMENTS</b>	
• Oven must be installed level.	• Hood installation is required.
• Water supply shut-off valve and back-flow preventer when required by local code.	

ELECTRICAL (DEDICATED CIRCUIT REQUIRED)								CombiSmoker®
MODEL	VOLTAGE	PH	HZ	AMPS	kW	AWG	CORD & PLUG	Additional kW
12•20ESi Touch	208 – 240	3	60	75.6 - 87.0 /ph	27.7 - 36.6	AWG 2	no cord or plug	+ .7 kw
	380 – 415	3	50/60	41.4 - 36.1 /ph	27.8 - 36.7	AWG 6	no cord or plug	+ .7 kw
	440 – 480	3*	60	36.0 - 43.5 /ph	27.8 - 36.7	AWG 6	no cord or plug	+ .7 kw
12•20ESi	208 – 240	3	60	75.6 - 87.0 /ph	27.7 - 36.6	AWG 2	no cord or plug	+ .7 kw
	380 – 415	3	50/60	41.4 - 36.1 /ph	27.7 - 36.6	AWG 6	no cord or plug	+ .7 kw
	440 – 480	3*	60	36.0 - 43.5 /ph	27.7 - 36.6	AWG 6	no cord or plug	+ .7 kw

\*ELECTRICAL SERVICE CHARGE APPLIES

WEIGHT		CAPACITY	
NET	665 lb (302 kg)	FULL-SIZE PANS:	20" x 12" x 2-1/2"
SHIP	750 lb (340 kg)	GN 1 / 1:	530 x 325 x 65mm
CRATE DIMENSIONS: (L x W x H)		GN 2 / 1:	650 x 530 x 65mm
53" x 53" x 87"		FULL-SIZE SHEET PANS:*	18" x 26" x 1"
(1346 x 1346 x 2210mm)		ON WIRE SHELVES ONLY	
288 lb (131 kg) MAXIMUM			
VOLUME MAXIMUM: 180 quarts (128 liters)			

\*ADDITIONAL WIRE SHELVES REQUIRED FOR MAXIMUM CAPACITY

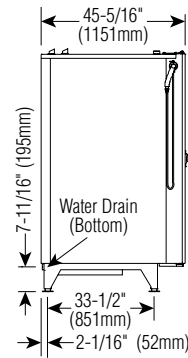
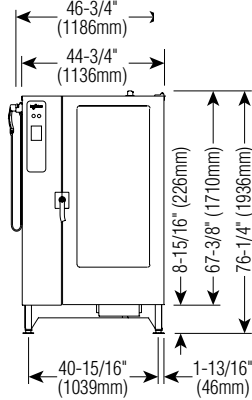
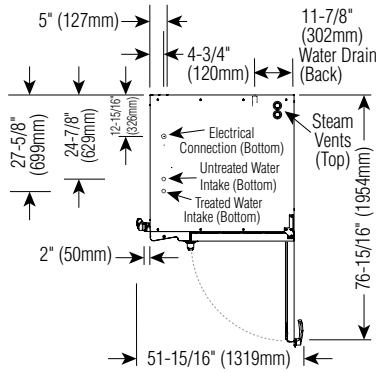

<b>DIMENSIONS:</b> H x W x D
<b>EXTERIOR:</b> 76-1/4" x 46-3/4" x 48" (1936mm x 1186mm x 1218mm)
<b>EXTERIOR WITH RECESSED DOOR:</b> 76-1/4" x 50-3/4" x 48" (1936mm x 1288mm x 1218mm)
<b>INTERIOR:</b> 60-1/4" x 26-1/4" x 32-11/16" (1530mm x 667mm x 830mm)

<b>WATER REQUIREMENTS</b>
<b>TWO (2) COLD WATER INLETS - DRINKING QUALITY</b>
ONE (1) TREATED WATER INLET: 3/4" NPT*      * Can manifold off of one 3/4" line.
ONE (1) UNTREATED WATER INLET: 3/4" NPT*
LINE PRESSURE: 30 to 90 psi    2.8 to 6.2 bar
WATER DRAIN: 1-1/2" CONNECTION WITH A 2" MINIMUM AIR GAP INSTALLED AS CLOSE TO THE OVEN AS POSSIBLE

<b>WATER QUALITY MINIMUM STANDARDS</b>																
USING A WATER SUPPLY NOT MEETING ALTO-SHAAM'S MINIMUM WATER QUALITY STANDARDS WILL VOID THIS WARRANTY. It is the responsibility of the purchaser to ensure that incoming water supply is compliant with the specifications listed through adequate treatment measures. Installation of the CombiGuard™ Water Filtration System is recommended, but this system may not address all water quality issues present.																
<table border="1"> <thead> <tr> <th>Contaminant</th> <th>Inlet Water Requirements (untreated water)</th> </tr> </thead> <tbody> <tr> <td>Free Chlorine</td> <td>Less than 0.1 ppm (mg/L)</td> </tr> <tr> <td>Hardness</td> <td>Less than 3 gpg (52 ppm)</td> </tr> <tr> <td>Chloride</td> <td>Less than 30 ppm (mg/L)</td> </tr> <tr> <td>pH</td> <td>7.0 to 8.5</td> </tr> <tr> <td>Alkalinity</td> <td>Less than 50 ppm (mg/L)</td> </tr> <tr> <td>Silica</td> <td>Less than 12 ppm (mg/L)</td> </tr> <tr> <td>Total Dissolved Solids (tds)</td> <td>Less than 60 ppm</td> </tr> </tbody> </table>	Contaminant	Inlet Water Requirements (untreated water)	Free Chlorine	Less than 0.1 ppm (mg/L)	Hardness	Less than 3 gpg (52 ppm)	Chloride	Less than 30 ppm (mg/L)	pH	7.0 to 8.5	Alkalinity	Less than 50 ppm (mg/L)	Silica	Less than 12 ppm (mg/L)	Total Dissolved Solids (tds)	Less than 60 ppm
Contaminant	Inlet Water Requirements (untreated water)															
Free Chlorine	Less than 0.1 ppm (mg/L)															
Hardness	Less than 3 gpg (52 ppm)															
Chloride	Less than 30 ppm (mg/L)															
pH	7.0 to 8.5															
Alkalinity	Less than 50 ppm (mg/L)															
Silica	Less than 12 ppm (mg/L)															
Total Dissolved Solids (tds)	Less than 60 ppm															

<b>CLEARANCE REQUIREMENTS</b>
<b>LEFT</b> 6" (152mm) <b>RECOMMENDED SERVICE ACCESS: 18" (457mm)</b> 20" (508mm) <b>FROM HEAT PRODUCING EQUIPMENT</b>
<b>RIGHT</b> 4" (102mm) <b>TOP:</b> 20" (508mm) <b>FOR AIR MOVEMENT</b>
<b>BACK</b> 4" (102mm) <b>BOTTOM:</b> 5-1/8" (130mm) <b>FOR LEGS</b>

<b>INSTALLATION REQUIREMENTS</b>
<ul style="list-style-type: none"> <li>Oven must be installed level.</li> <li>Water supply shut-off valve and back-flow preventer when required by local code.</li> <li>Hood installation is required.</li> </ul>

<b>ELECTRICAL (DEDICATED CIRCUIT REQUIRED)</b>							
MODEL	VOLTAGE	PH	HZ	AMPS	kW	AWG	CORD & PLUG
20•20ES Touch	208 – 240	3	60	151.2 - 173.9 / ph	55.3 - 73.2	AWG 4	no cord or plug
	380 – 415	3	50/60	83.0 - 101.0 / ph	55.3 - 73.2	AWG 2	no cord or plug
	440 – 480	3*	60	71.5 - 87.0 / ph	55.3 - 73.2	AWG 2	no cord or plug
20•20ES	208 – 240	3	60	151.2 - 173.9 / ph	54.4 - 72.2	AWG 4	no cord or plug
	380 – 415	3	50/60	83.0 - 101.0 / ph	55.4 - 72.2	AWG 2	no cord or plug
	440 – 480	3*	60	71.5 - 87.0 / ph	54.4 - 72.2	AWG 2	no cord or plug

\*ELECTRICAL SERVICE CHARGE APPLIES

<b>WEIGHT</b>	<b>CAPACITY</b>											
NET 958 lb (435 kg)	<table border="1"> <tr> <td>FULL-SIZE PANS:</td> <td>20" x 12" x 2-1/2"</td> <td rowspan="2">Forty (40)</td> </tr> <tr> <td>GN 1 / 1:</td> <td>530 x 325 x 65mm</td> </tr> <tr> <td>GN 2 / 1:</td> <td>650 x 530 x 65mm</td> <td>Twenty (20)</td> </tr> <tr> <td>FULL-SIZE SHEET PANS:* ON WIRE SHELVES ONLY</td> <td>18" x 26" x 1"</td> <td>Twenty (20)</td> </tr> </table>	FULL-SIZE PANS:	20" x 12" x 2-1/2"	Forty (40)	GN 1 / 1:	530 x 325 x 65mm	GN 2 / 1:	650 x 530 x 65mm	Twenty (20)	FULL-SIZE SHEET PANS:* ON WIRE SHELVES ONLY	18" x 26" x 1"	Twenty (20)
FULL-SIZE PANS:		20" x 12" x 2-1/2"	Forty (40)									
GN 1 / 1:	530 x 325 x 65mm											
GN 2 / 1:	650 x 530 x 65mm	Twenty (20)										
FULL-SIZE SHEET PANS:* ON WIRE SHELVES ONLY	18" x 26" x 1"	Twenty (20)										
SHIP 1364 lb (619 kg)	480 lb (218 kg) MAXIMUM											
CRATE DIMENSIONS: (L x W x H) 53" x 53" x 87" (1346 x 1346 x 2210mm)	VOLUME MAXIMUM: 300 quarts (380 liters)											

\*ADDITIONAL WIRE SHELVES REQUIRED FOR MAXIMUM CAPACITY

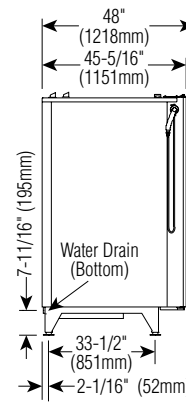
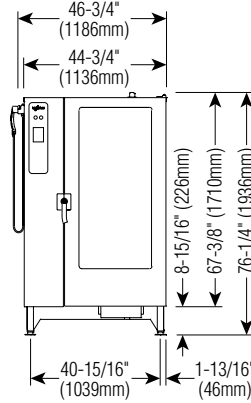
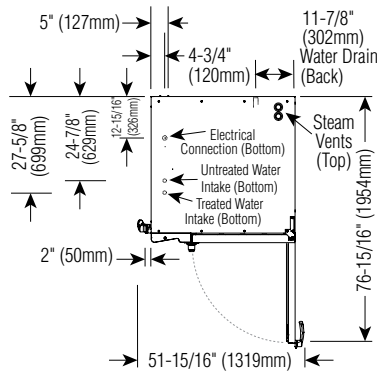

<b>DIMENSIONS:</b> H x W x D
<b>EXTERIOR:</b> 76-1/4" x 46-3/4" x 48" (1936mm x 1186mm x 1218mm)
<b>EXTERIOR WITH RECESSED DOOR:</b> 76-1/4" x 50-3/4" x 48" (1936mm x 1288mm x 1218mm)
<b>INTERIOR:</b> 60-1/4" x 26-1/4" x 32-11/16" (1530mm x 667mm x 830mm)

<b>WATER REQUIREMENTS</b>
<p><b>TWO (2) COLD WATER INLETS - DRINKING QUALITY</b></p> <p>ONE (1) TREATED WATER INLET: 3/4" NPT* * Can manifold off of one 3/4" line.</p> <p>ONE (1) UNTREATED WATER INLET: 3/4" NPT*</p> <p>LINE PRESSURE: 30 to 90 psi 2.8 to 6.2 bar</p> <p>WATER DRAIN: 1-1/2" CONNECTION WITH A 2" MINIMUM AIR GAP INSTALLED AS CLOSE TO THE OVEN AS POSSIBLE</p>
<b>CLEARANCE REQUIREMENTS</b>
<p><b>LEFT</b> 6" (152mm) <b>RECOMMENDED SERVICE ACCESS: 18" (457mm)</b> 20" (508mm) <b>FROM HEAT PRODUCING EQUIPMENT</b></p> <p><b>RIGHT</b> 4" (102mm) <b>TOP:</b> 20" (508mm) <b>FOR AIR MOVEMENT</b></p> <p><b>BACK</b> 4" (102mm) <b>BOTTOM:</b> 5-1/8" (130mm) <b>FOR LEGS</b></p>

<b>WATER QUALITY MINIMUM STANDARDS</b>																
<p>USING A WATER SUPPLY NOT MEETING ALTO-SHAAM'S MINIMUM WATER QUALITY STANDARDS WILL VOID THIS WARRANTY. It is the responsibility of the purchaser to ensure that incoming water supply is compliant with the specifications listed through adequate treatment measures. Installation of the CombiGuard™ Water Filtration System is recommended, but this system may not address all water quality issues present.</p>																
<table border="1"> <thead> <tr> <th>Contaminant</th> <th>Inlet Water Requirements (untreated water)</th> </tr> </thead> <tbody> <tr> <td>Free Chlorine</td> <td>Less than 0.1 ppm (mg/L)</td> </tr> <tr> <td>Hardness</td> <td>Less than 3 gpg (52 ppm)</td> </tr> <tr> <td>Chloride</td> <td>Less than 30 ppm (mg/L)</td> </tr> <tr> <td>pH</td> <td>7.0 to 8.5</td> </tr> <tr> <td>Alkalinity</td> <td>Less than 50 ppm (mg/L)</td> </tr> <tr> <td>Silica</td> <td>Less than 12 ppm (mg/L)</td> </tr> <tr> <td>Total Dissolved Solids (tds)</td> <td>Less than 60 ppm</td> </tr> </tbody> </table>	Contaminant	Inlet Water Requirements (untreated water)	Free Chlorine	Less than 0.1 ppm (mg/L)	Hardness	Less than 3 gpg (52 ppm)	Chloride	Less than 30 ppm (mg/L)	pH	7.0 to 8.5	Alkalinity	Less than 50 ppm (mg/L)	Silica	Less than 12 ppm (mg/L)	Total Dissolved Solids (tds)	Less than 60 ppm
Contaminant	Inlet Water Requirements (untreated water)															
Free Chlorine	Less than 0.1 ppm (mg/L)															
Hardness	Less than 3 gpg (52 ppm)															
Chloride	Less than 30 ppm (mg/L)															
pH	7.0 to 8.5															
Alkalinity	Less than 50 ppm (mg/L)															
Silica	Less than 12 ppm (mg/L)															
Total Dissolved Solids (tds)	Less than 60 ppm															

<b>INSTALLATION REQUIREMENTS</b>
<ul style="list-style-type: none"> <li>Oven must be installed level.</li> <li>Hood installation is required.</li> <li>Water supply shut-off valve and back-flow preventer when required by local code.</li> </ul>

ELECTRICAL (DEDICATED CIRCUIT REQUIRED)								CombiSmoker®
MODEL	VOLTAGE	PH	HZ	AMPS	kW	AWG	CORD & PLUG	Additional kW
20•20ESi Touch	208 - 240	3	60	151.2 - 173.9/ph	55.3 - 73.2	AWG 4	no cord or plug	+ .7 kw
	380 - 415	3	50/60	83.0 - 101.0/ph	55.3 - 73.2	AWG 2	no cord or plug	+ .7 kw
	440 - 480	3*	60	71.5 - 87.0/ph	55.3 - 73.2	AWG 2	no cord or plug	+ .7 kw
20•20ESi	208 - 240	3	60	151.2 - 173.9/ph	55.4 - 73.2	AWG 4	no cord or plug	+ .7 kw
	380 - 415	3	50/60	83.0 - 101.0/ph	55.4 - 73.2	AWG 2	no cord or plug	+ .7 kw
	440 - 480	3*	60	71.5 - 87.0/ph	55.4 - 73.2	AWG 2	no cord or plug	+ .7 kw

\*ELECTRICAL SERVICE CHARGE APPLIES

WEIGHT		CAPACITY		
NET	958 lb (435 kg)	FULL-SIZE PANS:	20" x 12" x 2-1/2"	Forty (40)
SHIP	1364 lb (619 kg)	GN 1/1:	530 x 325 x 65mm	Forty (40)
CRATE DIMENSIONS: (L x W x H) 53" x 53" x 87" (1346 x 1346 x 2210mm)		GN 2/1:	650 x 530 x 65mm	Twenty (20)
		FULL-SIZE SHEET PANS:* ON WIRE SHELVES ONLY	18" x 26" x 1"	Twenty (20)
480 lb (218 kg) MAXIMUM				
VOLUME MAXIMUM: 300 quarts (380 liters)				

\*ADDITIONAL WIRE SHELVES REQUIRED FOR MAXIMUM CAPACITY

# INSTALLATION

## ELECTRICAL CONNECTION



### DANGER



ENSURE POWER SOURCE  
MATCHES VOLTAGE IDENTIFIED  
ON APPLIANCE RATING TAG.

### DANGER



APPLIANCES WITH NO CORD  
PROVIDED BY FACTORY MUST  
BE EQUIPPED WITH A CORD OF  
SUFFICIENT LENGTH TO PERMIT  
THE APPLIANCE TO BE MOVED  
FOR CLEANING.



ELECTRICAL CONNECTIONS MUST  
BE MADE BY A QUALIFIED SERVICE  
TECHNICIAN IN ACCORDANCE WITH  
APPLICABLE ELECTRICAL CODES.

#### Hard wired models:

Hard wired models must be equipped with a country certified external allpole disconnection switch with sufficient contact separation.

If a power cord is used for the connection of the product an oil resistant cord like H05RN or H07RN or equivalent must be used.

1. An electrical wiring diagram is located behind the control panel on the left side of the oven. This appliance must be branch circuit protected with proper ampacities, in accordance with the wiring diagram.
2. Wire size for the main incoming power to the unit must match the minimum size listed in the specifications applicable to the specific oven model. For supply connections, locate the wire size posted on the label located on the electrical control box cover, behind the service panel.
3. When connecting to a Delta-B (wild leg) on a 3-phase system, the wild leg must be connected to line 3.
4. Before operating the oven, check all cable connections in the electrical connection area for tightness since connections can loosen during transport.

### DANGER



To avoid electrical shock, this appliance **MUST** be adequately grounded in accordance with local electrical codes or, in the absence of local codes, with the current edition of the National Electrical Code ANSI/NFPA No. 70. In Canada, all electrical connections are to be made in accordance with CSA C22.1, Canadian Electrical Code Part 1 or local codes.



### DANGER



IMPROPER INSTALLATION,  
ALTERATION, ADJUSTMENT,  
SERVICE, OR MAINTENANCE COULD  
RESULT IN SEVERE INJURY, DEATH,  
OR CAUSE PROPERTY DAMAGE.  
**READ THE INSTALLATION,  
OPERATING AND MAINTENANCE  
INSTRUCTIONS THOROUGHLY  
BEFORE INSTALLING OR SERVICING  
THIS EQUIPMENT.**

**NOTE:** CE approved appliances must be connected to an electrical circuit that is protected by an external GFCI outlet.

**NOTE:** After both water and electrical connections have been completed, operate the oven in any cooking mode for a period of 15 minutes and recheck the main power connections at the terminal block to make certain they remain tight. [The need to check motor rotation no longer applies to the Combitouch® model line.]

#### 380-415V:

**For CE approved units:** To prevent an electrical shock hazard between the appliance and other appliances or metal parts in close vicinity, an equalization-bonding stud is provided. An equalization bonding lead must be connected to this stud and the other appliances / metal parts to provide sufficient protection against potential difference. The terminal is marked with the following symbol.





# INSTALLATION

## ELECTRICAL CONNECTION



### DANGER



ELECTRICAL CONNECTIONS MUST BE MADE BY A QUALIFIED SERVICE TECHNICIAN IN ACCORDANCE WITH APPLICABLE ELECTRICAL CODES.



### DANGER



To avoid electrical shock, this appliance **MUST** be adequately grounded in accordance with local electrical codes or, in the absence of local codes, with the current edition of the National Electrical Code ANSI/NFPA No. 70. In Canada, all electrical connections are to be made in accordance with CSA C22.1, Canadian Electrical Code Part 1 or local codes.

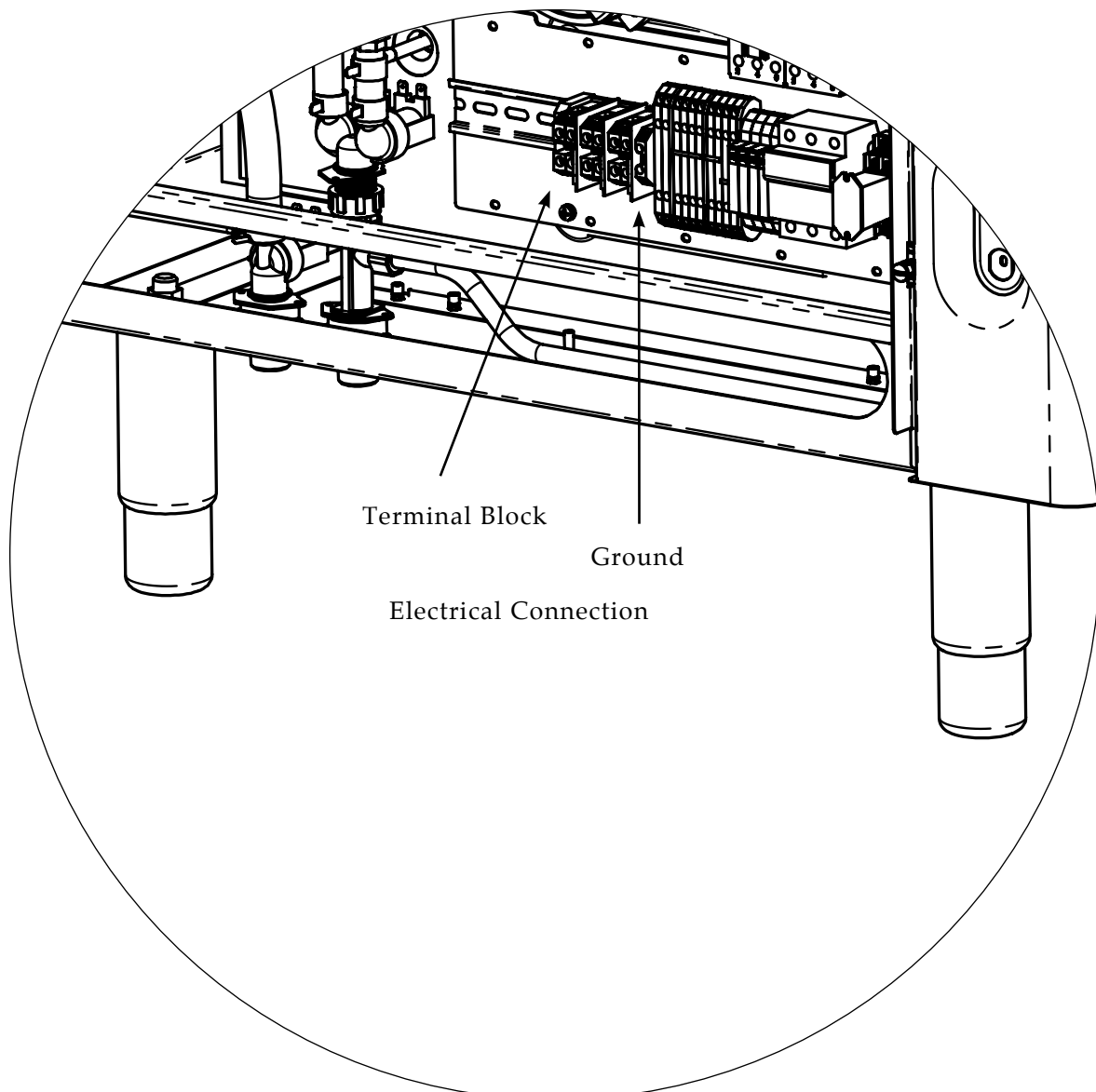

# INSTALLATION

## MOBILE EQUIPMENT RESTRAINT

Any appliance that is not furnished with a power supply cord but includes a set of casters must be installed with a tether. Adequate means must be provided to limit the movement of this appliance without depending on or transmitting stress to the electrical conduit. The following requirements apply:

1. Casters must be a maximum height of 6" (152mm).
2. Two of the casters must be the locking type.
3. Such mobile appliances or appliances on mobile stands must be installed with the use of a flexible connector secured to the building structure.

A mounting connector for a restraining device is located on the lower back flange of the appliance chassis or on an oven stand, approximately 18" (457mm) from the floor. A flexible connector is not supplied by nor is it available from the factory.

	
<b>WARNING</b>	
	<b>RISK OF ELECTRIC SHOCK.</b> Appliance must be secured to building structure.

# INSTALLATION

## WATER QUALITY REQUIREMENT

### USE A DRINKING QUALITY, COLD WATER SUPPLY ONLY

Water quality is of critical importance when installing steam producing equipment of any kind, particularly *high temperature* steam producing equipment. Water that is perfectly safe to drink is composed of chemical characteristics that directly affect the metal surfaces of steam producing equipment. These chemical characteristics differ greatly from region to region throughout the U.S. and the world. *Varying combinations of pH; alkalinity; hardness; chlorides; total dissolved solids; and other chemical characteristics, when subjected to high temperatures, will cause water to have a tendency to either scale or corrode.*

Alto-Shaam has consulted with people who understand the properties of water in order to provide water quality standards that meet the broadest possible range of acceptable water quality requirements to help protect your investment.

We strongly urge water testing to ascertain the water quality on site prior to the installation of any steam producing equipment. Since water quality is an important issue, Alto-Shaam is committed to provide as much information as possible to help protect the investment made in this equipment.

A CombiGuard™ Water Filtration System can be purchased as an option for installation on the Combitherm oven. This filter, when properly installed, maintained, and combined with the required levels of steam generating equipment maintenance, will help lessen the affect water has on metal surfaces. It will not, however, provide complete protection against all water damage from region to region.

Due to the complexity of water chemistry, it is important to understand that water quality plays a significant role in the longevity of steam producing equipment. Water quality and required maintenance of steam generating equipment is the direct responsibility of the owner/operator. Damage incurred as a direct result of poor water quality and/or surfaces affected by water quality is also the responsibility of the owner/operator. Damage due to water quality that does not meet the minimum standards shown below is not covered under the Alto-Shaam Combitherm warranty.

Alto-Shaam will continue our efforts to provide viable solutions to ease the impact of water quality as it relates to steam generating equipment.

### ALTO-SHAAM COMBITHERM WATER QUALITY MINIMUM STANDARDS

CONTAMINANT	INLET WATER REQUIREMENTS (UNTREATED WATER)
Free Chlorine	Less than 0.1 ppm (mg/L)
Hardness	Less than 3 gpg (52 ppm)
Chloride	Less than 30 ppm (mg/L)
pH	7.0 to 8.5
Alkalinity	Less than 50 ppm (mg/L)
Silica	Less than 12 ppm (mg/L)
Total Dissolved Solids (tds)	Less than 60 ppm

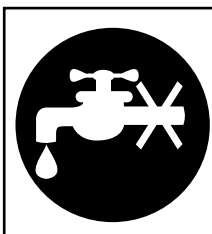

### WARNING

TO PREVENT WATER PIPES OR HOSES FROM BURSTING, INCOMING WATER SUPPLY SHOULD BE TURNED OFF WHEN THE APPLIANCE IS NOT IN USE.



### WARNING

WATER SUPPLY MUST BE OPEN WHEN CLEANING PROGRAM IS ACTIVATED. VERIFY WATER SUPPLY BEFORE STARTING CLEANING PROGRAM.

# INSTALLATION

## WATER CONNECTIONS

### WATER REQUIREMENTS

#### TWO (2) COLD WATER INLETS - DRINKING QUALITY

**ONE (1) TREATED WATER INLET:** 3/4" NPT\*

**ONE (1) UNTREATED WATER INLET:** 3/4" NPT\*

**LINE PRESSURE:** 30 to 90 psi  
2.8 to 6.2 bar

\* Can manifold off of one 3/4" line

REFER TO PUBLISHED SPECIFIC WATER REQUIREMENTS

**WATER DRAIN:** 1-1/2" CONNECTION WITH AIR GAP

Flush the water line at the installation site.

Install water intake filters (provided) [see Figure 1] before connecting the oven to the water supply.

A hose connector is supplied for flexible hose connection to the **COLD** water source.

**Backflow Prevention** — The equipment must be installed with adequate backflow protection to comply with applicable federal, state, and local codes.

**PIPE SEALING TAPE (TEFLON®) MUST BE USED AT ALL CONNECTION POINTS.** The use of a pipe sealing compound is not recommended.

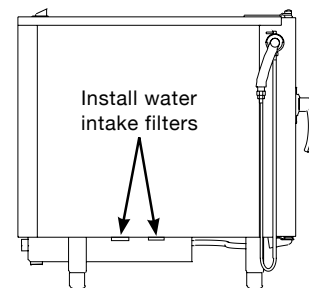
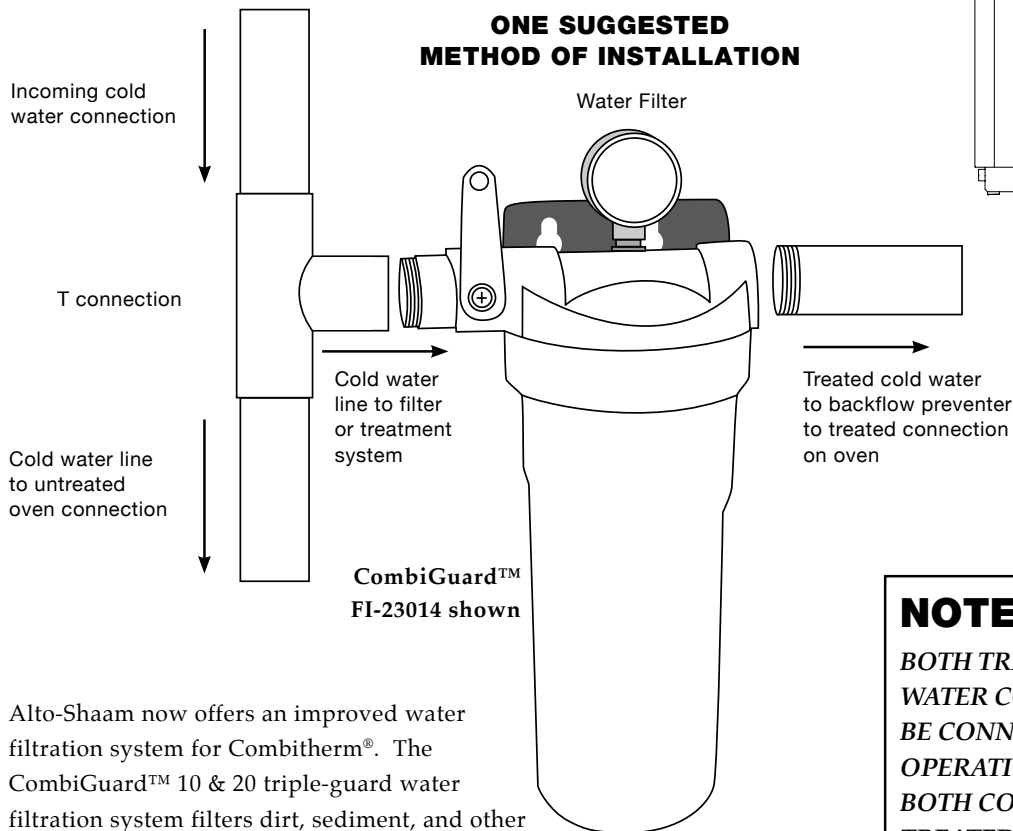

Figure 1

Alto-Shaam now offers an improved water filtration system for Combitherm®. The CombiGuard™ 10 & 20 triple-guard water filtration system filters dirt, sediment, and other debris as small as 1/2 micron. This system also significantly reduces chlorine content to protect against corrosive chlorine compounds. CombiGuard improves equipment efficiency, reduces service requirements and extends the life of the Combi oven. After installation, confirm that water quality standards specified in this manual are being met. Filtration systems include one filter cartridge. Additional cartridges can be purchased separately. Refer to an earlier page for additional ordering information.

The CombiGuard™ BWS Blended Water System utilizes reverse osmosis to remove more than 97% of the total dissolved solids from water which can be precisely blended with filtered and treated water.

### NOTE:

**BOTH TREATED AND UNTREATED WATER CONNECTIONS MUST BE CONNECTED FOR PROPER OPERATION OF THE OVEN. BOTH CONNECTIONS CAN BE TREATED WATER, BUT SHOULD NEVER BE CONNECTED TO ONLY UNTREATED WATER.**

**UNIONS OR FLEXIBLE LINES SHOULD BE USED TO ALLOW FOR OVEN MOVEMENT WHEN BEING SERVICED OR CLEANING IS NEEDED.**

# INSTALLATION

## WATER VALVE

### NOTE:

THE SHUT-OFF VALVE  
MUST BE IN THE OPEN POSITION  
WHEN THE OVEN IS BEING USED.

SHUT-OFF VALVE SHOWN  
IN THE OFF POSITION



## WATER DRAINAGE

The oven must discharge through an indirect waste pipe by means of an air gap. The drain fitting is supplied with a 1-1/2-inch (41mm) NPT thread.

A union is required. Install a 1-1/2-inch (41mm) diameter connection, drain line and clamp into place. The drain line must always be a positive gradient away from the Combitherm oven and not more than 12-inches (305mm) before an air gap.

**NOTE:** In the U.S.A., this equipment is to be installed to comply with the Basic Plumbing Code of the Building Officials and Code Administrators International, Inc. [BOCA], and the Food Service Sanitation Manual of the Food & Drug Administration [FDA].

If several units are to be connected to one drain pipe, the dimensions of the pipe must be sufficient to allow an unobstructed water drain system.

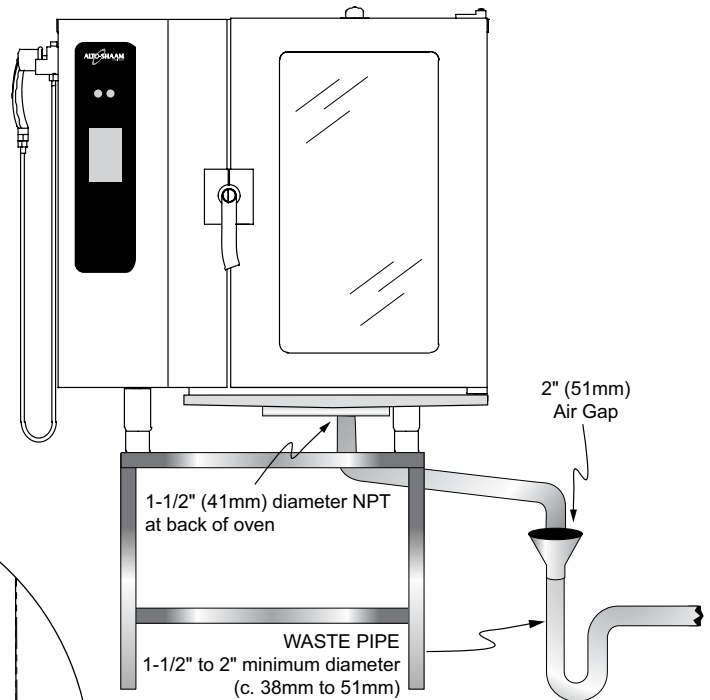
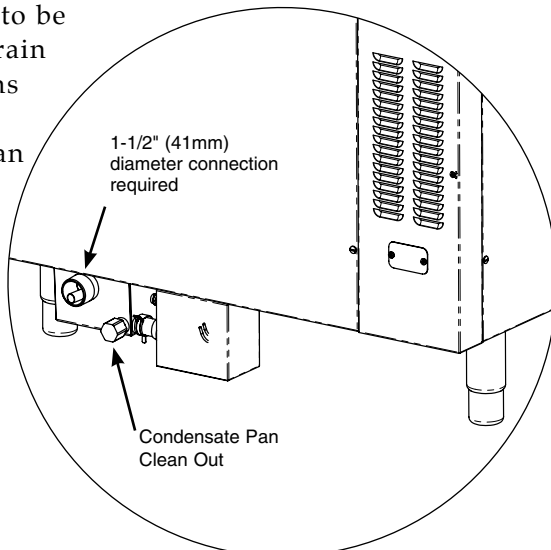

# INSTALLATION

## GREASE COLLECTION HOOK-UP (IF EQUIPPED WITH THIS FEATURE)



- Grease Collection Hose Assembly is attached to the oven in the back.
- Place Grease Collection Containers inside the tray of the Mobile Grease Collection Cart. Roll into place next to the oven.
- Remove cap from container. Pull out the Grease Collection Hose Assembly from the back of the unit.
- Screw on to collection container until snug.
- Turn ball valve handle to the **ON** position.
- Automatic Grease Collection System is electronically activated during the chicken cooking process [PATENT PENDING]. It is designed to save labor and provide greater employee safety by eliminating the need to handle hot grease in shallow pans.

Optional  
Mobile  
Grease  
Collection  
Cart

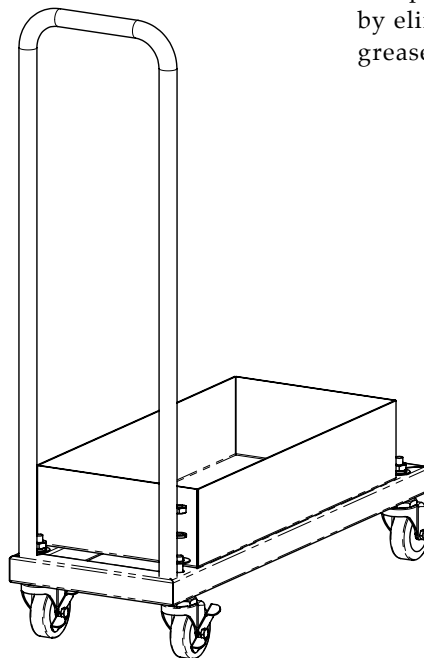

# INSTALLATION

## COMBITOUCH® CHECKLIST

Use this list as a final check of oven installation conformance.

Damage directly attributed to improper set up, installation, or cleaning can invalidate warranty claims.

### **CLEARANCES:**

Left: 6" (152mm) — Service access of 18" (457mm) recommended.  
 20" (508mm) from heat producing equipment.  
 Right: 4" (102mm)  
 Back: 4" (102mm) for plumbing  
 Top: 20" (508mm) for air movement

ARE ALL CLEARANCE

REQUIREMENTS MET?  YES  NO

IF NO, EXPLAIN: \_\_\_\_\_

### **WATER SUPPLY AND DRAINS:**

Verify hook-up to *TWO* (2) separate *cold* water supply lines with a <sup>3</sup>/<sub>4</sub>" (19mm) water connection supply line. Verify inlet water pressure is at a minimum of 30 PSI (2.8 bar). Maximum water pressure is not to exceed 90 PSI (6 bar). Verify drain diameter of 1-1/2" (41mm) with a positive descending slope, and with a 2" (51mm) air gap which is free of obstructions before connection to the site drain. Verify 1/8" (3.2mm) pitch to 10' (305cm) of drain line.  
**IMPORTANT: Alto-Shaam has listed Water Quality Requirements in the installation manual for this equipment. It is the responsibility of the end user to have the water connected to this appliance tested to ensure these standards are met before putting the oven into use. Failure to meet these standards will void the warranty if damage to the oven is found to be related to water quality.**

ARE BOTH WATER SUPPLY LINES

PROPERLY CONNECTED?  YES  NO

IF NO, EXPLAIN: \_\_\_\_\_

IS A FILTER SYSTEM INSTALLED ON THIS UNIT?  YES  NO

STORE HAS SEEN THIS RECOMMENDATION:  YES  NO

SIGNATURE OF STORE REPRESENTATIVE: \_\_\_\_\_

### **ELECTRICAL CONNECTIONS:**

Verify electrical power requirements for oven.  
 Verify voltage at terminal block.  
 Check all terminals for tightness.

**VOLTAGE:** \_\_\_\_\_

**PHASE:** \_\_\_\_\_

**BREAKER SIZE:** \_\_\_\_\_

LINE VOLTAGE AT TERMINAL BLOCK (TO GROUND):

LINE 1: \_\_\_\_\_ LINE 2: \_\_\_\_\_ LINE 3: \_\_\_\_\_

LINE VOLTAGE (PHASE TO PHASE): LINE 1 to 2: \_\_\_\_\_

LINE 2 to 3: \_\_\_\_\_

LINE 3 to 1: \_\_\_\_\_

ELECTRICAL SUPPLY LINE SIZE: \_\_\_\_\_

ALL ELECTRICAL TERMINALS TIGHT:  YES  NO

### **CONTROL BOARD CONNECTIONS & OPERATION:**

With the Power ON, press the Set-Up Key to access software version, and record.

ALL BOARD CONNECTIONS TIGHT:  YES  NO

ALL FUNCTIONS ARE DISPLAYED:  YES  NO

ALL FUNCTIONS ON CONTROL OPERATE:  YES  NO

UNIT OPERATES IN ALL MODES:  YES  NO

SOFTWARE VERSION:

RB \_\_\_\_\_ DB \_\_\_\_\_

IF NO, EXPLAIN: \_\_\_\_\_

### **PHYSICAL CONDITION:**

\*REFERENCE INSTALLATION INSTRUCTIONS FOR COMPLETE INFORMATION

- Bottom of oven has been checked for damage due to improper positioning on site .....
- Verify all gaskets, hoses, and carts\* are in place and function properly .....
- If oven includes a cart, verify proper installation of the rack guide on companion warmer or chiller\* .....
- Verify the installation of drip pans\*, racks, shelves, drain screen, spray hose\* .....
- Verify the oven is level and installed on a solid, water resistant floor .....

<b>SERVICE AGENCY:</b>	<b>START-UP DATE:</b>
	<b>INSTALLATION NAME:</b>
<b>MODEL NO.:</b>	<b>SERIAL NO.:</b>
<b>TECH SIGNATURE:</b>	<b>CUSTOMER SIGNATURE:</b>

# INSTALLATION

## ERROR CODES

*This section is provided for the assistance of qualified technicians only and is not intended for use by untrained or unauthorized service personnel. If your Alto-Shaam® unit is not operating properly, check the following before calling your Authorized Alto-Shaam Service Agent:*

- ☛ Check that unit is receiving power. Circuit breaker turned on?

*Do not attempt to repair or service the oven beyond this point. Contact Alto-Shaam for the nearest authorized service agent. Repairs made by any other service agents without prior authorization by Alto-Shaam will void the warranty on the unit.*

When the oven malfunctions, an error code will appear in the display.



**PRESS THE START ICON TO ACKNOWLEDGE THE ERROR.**

The icons that begin to flash represent operational modes that are still usable.

When the oven fault is corrected, the Combitherm will return to normal operation.

<b>Error Code</b>	<b>Error Call Out in Display</b>	<b>Description of Error</b>	<b>Possible Cause</b>
<b>E01</b>	Low Water Boiler	Low water level in boiler	<ul style="list-style-type: none"> <li>— Water supply is shut off.</li> <li>— Low water pressure.</li> <li>— Generator drain cap missing or loose.</li> <li>— Generator drain pump is not sealing.</li> <li>— Generator drain pump elbow leaking.</li> <li>— Faulty or scaled water level probe.</li> <li>— Faulty or plugged dual solenoid valve assembly.</li> <li>— Wiring or connection issue.</li> <li>— No output to dual solenoid from relay board.</li> <li>— Relay board, high voltage is not operating.</li> </ul>
<b>E02</b>	Control Temperature High	Relay board surface temperature too high	<ul style="list-style-type: none"> <li>— Wiring or connection issue.</li> <li>— Cooling fan on Relay board assembly is not operating.</li> <li>— Cooling Fan on display board is not operating.</li> <li>— Main Cooling fan is not operating.</li> <li>— Cooling Fan on motor drive is not operating.</li> <li>— Unit is less than 20" from a heat producing source on its left hand side.</li> </ul>
<b>E03</b>	Fan Motor Error	Fan motor does not work	<ul style="list-style-type: none"> <li>— Exhaust hood is not operating properly.</li> <li>— Check LED flashes on the Motor Control.</li> <li>— <b>See Motor Control Error Code list.</b></li> <li>— Connection Issue on Hall Effect sensor.</li> <li>— Fan wheel is not operating.</li> <li>— Hall sensor does not detect motor rotation.</li> </ul>
<b>E04</b>	Fan Motor 2 Error	Lower fan motor on 20•20 does not work	<ul style="list-style-type: none"> <li>— Exhaust hood is not operating properly.</li> <li>— Check LED flashes on the Motor Control.</li> <li>— <b>See Motor Control Error Code list.</b></li> <li>— Connection Issue on Hall Effect sensor.</li> <li>— Fan wheel is not operating.</li> <li>— Hall sensor does not detect motor rotation.</li> </ul>
<b>E11</b>	Convection Temperature High	Excess oven temperature	<p>Convection Mode &amp; Combi Mode:</p> <ul style="list-style-type: none"> <li>— Convection Oven contactor(s) stuck closed.</li> <li>— N6 Oven Cavity Temperature probe defective.</li> <li>— N6 Cavity Probe connection problem.</li> <li>— Relay board, high voltage is not operating.</li> <li>— Wiring or connection issue.</li> </ul> <p>Combi Mode Only:</p> <ul style="list-style-type: none"> <li>— Insufficient water supply into oven for steam production.</li> </ul>

CONTINUED ON NEXT PAGE



# INSTALLATION

## ERROR CODES

Error Code	Error Call Out in Display	Description of Error	Possible Cause
<b>E13</b>	Boiler Temperature High	Boiler temperature overheats	<ul style="list-style-type: none"> <li>— Scale build up inside steam generator.</li> <li>— Scale build up on water level probe.</li> <li>— B4 Probe connection problem.</li> <li>— B4 probe faulty.</li> </ul>
<b>E15</b>	Condensor Temperature High	Excess condensor temperature	<ul style="list-style-type: none"> <li>— Untreated water supply line is shut off.</li> <li>— Untreated water supply line is connected to warm water.</li> <li>— B3 probe connection problem.</li> <li>— B3 probe is faulty.</li> <li>— Single solenoid valve Y2 obstructed or faulty.</li> <li>— Wiring or connection problem.</li> <li>— Relay board, high voltage is not operating.</li> </ul>
<b>E20</b>	<p>HACCP Only - B11 Core Temperature Probe Single Point Fault</p> <p>Error E20 is not shown in display. Instead a probe sign with “?” is shown as popup window. In case the customer cooks in time mode during first step and during second step switches to probe mode but has no probe in place, the error E20 will be shown in the error code list and HACCP list.</p>	Single point core temperature probe defect or disconnected.	<ul style="list-style-type: none"> <li>— Clean Probe Receptacle Pins with sand paper.</li> <li>— B11 Single Point Core Temperature probe with quick connect, defective.</li> <li>— B11 Single Point Core Temperature probe wires with quick connect, disconnected.</li> <li>— B11 Single Point Core Temperature probe receptacle, defective.</li> <li>— B11 Single Point Core Temperature probe receptacle wires disconnected.</li> </ul>
<b>E21</b>	N6 Cavity Probe Fault	Cavity temperature probe defect or disconnected	<ul style="list-style-type: none"> <li>— N6 Oven Cavity Temperature probe defective.</li> <li>— N6 Oven Cavity Temperature connection problem.</li> </ul>
<b>E22</b>	B10 Core Temperature Probe Multipoint Fault	Multipoint core temperature probe defect or disconnected	<ul style="list-style-type: none"> <li>— B10 Multipoint Core Temperature probe defective.</li> <li>— B10 Multipoint Core Temperature probe connection problem.</li> </ul>
<b>E23</b>	B4 Boiler Probe Fault	Boiler temperature probe defect or disconnected	<ul style="list-style-type: none"> <li>— B4 Boiler temperature probe defective.</li> <li>— B4 probe wires connection problem.</li> </ul>
<b>E24</b>	B5 Bypass Probe Fault	Bypass steam temperature probe defect or disconnected	<ul style="list-style-type: none"> <li>— B5 Bypass steam temperature probe defective.</li> <li>— B5 Bypass steam temperature connection problem.</li> </ul>
<b>E25</b>	B3 Condensor Probe Fault	Condensor water temperature probe defect or disconnected	<ul style="list-style-type: none"> <li>— B3 Condensor temperature probe defective.</li> <li>— B3 Condensor probe connection problem.</li> </ul>
<b>E26</b>	N8 Boiler Safety Temperature Probe Fault	Steam generator heating element protection probe defect or disconnected	<ul style="list-style-type: none"> <li>— N8 Boiler temperature probe defective.</li> <li>— N8 probe connection problem.</li> </ul>
<b>E27</b>	Boiler Element Temperature High	Excess steam generator safety probe	<ul style="list-style-type: none"> <li>— Scale build up inside steam generator.</li> <li>— Scale build up on water level probe.</li> <li>— Water level probe connection failure.</li> <li>— N8 boiler temperature probe defective.</li> <li>— N8 probe connection problem.</li> <li>— Steam element contactor(s) stuck closed.</li> <li>— Wiring or connection problem.</li> </ul>

CONTINUED ON NEXT PAGE

# INSTALLATION

## ERROR CODES

Error Code	Error Call Out in Display	Description of Error	Possible Cause
<b>E34</b>	Steam Generator Drain Pump Fault	Water level in steam generator does not drop during cleaning program	<ul style="list-style-type: none"> <li>— Scale build up inside the steam generator drain pump.</li> <li>— Scale build up inside the steam generator affecting water level probes.</li> <li>— Generator drain pump is faulty.</li> <li>— Connection issue at drain pump.</li> <li>— No output to pump from relay board.</li> </ul>
<b>E36</b>	Steam Temperature High	Oven cavity temperature is too high when operating in a steam mode or cleaning program	<ul style="list-style-type: none"> <li>— Water supply is shut off.</li> <li>— Low water pressure.</li> <li>— Wiring or connection issue.</li> <li>— Water injection pipe obstructed.</li> <li>— Water flow control valve plugged or defective.</li> <li>— Dual solenoid valve Y-1 obstructed or defective.</li> <li>— No output to solenoid valve form relay board.</li> </ul>
<b>E51</b>	No Water In Boiler	Water inside steam generator does not reach low water level	<ul style="list-style-type: none"> <li>— Water supply is shut off.</li> <li>— Low water pressure.</li> <li>— Generator drain cap missing or loose.</li> <li>— Generator drain pump is not sealing.</li> <li>— Generator drain pump elbow leaking.</li> <li>— Faulty or scaled water level probe.</li> <li>— Faulty or plugged dual solenoid valve assembly.</li> <li>— Wiring or connection issue.</li> <li>— No output to dual solenoid from relay board.</li> </ul>
<b>E53</b>	Fan Motor High Temperature	Fan motor too hot	<ul style="list-style-type: none"> <li>— Exhaust hood is not operating properly.</li> <li>— Check LED flashes on the Motor Control.</li> <li>— <b>See Motor Control Error Code list.</b></li> <li>— Connection Issue on Hall Effect sensor.</li> <li>— Fan wheel is not operating.</li> <li>— Hall sensor does not detect motor rotation.</li> </ul>
<b>E54</b>	Fan Motor 2 High Temperature	20•20 lower fan motor too hot	<ul style="list-style-type: none"> <li>— Exhaust hood is not operating properly.</li> <li>— Check LED flashes on the Motor Control.</li> <li>— <b>See Motor Control Error Code list.</b></li> <li>— Connection Issue on Hall Effect sensor.</li> <li>— Fan wheel is not operating.</li> <li>— Hall sensor does not detect motor rotation.</li> </ul>
<b>E55</b>	Vent Not Open	Browning valve does not open	<ul style="list-style-type: none"> <li>— Alignment issue between motor cam and vent motor safety switch (micro switch).</li> <li>— Fault vent valve (motor).</li> <li>— Fault vent valve safety switch (micro switch).</li> <li>— Wiring or connection problem.</li> </ul>

CONTINUED ON NEXT PAGE

# INSTALLATION

## ERROR CODES

<b>Error Code</b>	<b>Error Call Out in Display</b>	<b>Description of Error</b>	<b>Possible Cause</b>
<b>E57</b>	No Rinse Water	During rinse no water flow is detected through solenoid valve	<ul style="list-style-type: none"> <li>— Water supply is shut off.</li> <li>— Low water pressure.</li> <li>— Check wiring to all components mentioned below.</li> <li>— Flow switch is dirty or defective.</li> <li>— Dual water solenoid valve obstructed or faulty (Y3.)</li> <li>— Relay board, high voltage, defective.</li> </ul>
<b>E93</b>	Communication Error, FROM Display Board	Communication error between display board and low voltage relay board	<ul style="list-style-type: none"> <li>— Check ribbon cable connections mentioned below.</li> <li>— Ribbon cable defective.</li> <li>— Relay board, low voltage, connector defective.</li> <li>— Display board connector defective.</li> </ul>
<b>E94</b>	Communication Error, TO Display Board	Communication error between display board and low voltage relay board	<ul style="list-style-type: none"> <li>— Check ribbon cable connections mentioned below.</li> <li>— Ribbon cable defective.</li> <li>— Relay board, low voltage, connector defective.</li> <li>— Display board connector defective.</li> </ul>
<b>E98</b>	RB is in Cesium and DB is in Fahrenheit	Conflict of unit configuration in the setup menu	<ul style="list-style-type: none"> <li>— Relay board and Data board do not match, use setup menu to change format.</li> </ul>
<b>E99</b>	RB is in Fahrenheit and DB is in Cesium	Conflict of unit configuration in the setup menu	<ul style="list-style-type: none"> <li>— Relay board and Data board do not match, use setup menu to change format.</li> </ul>
<b>E100</b>	DB is not equal to RB version. Error generated by DB.	Software update may have failed.	<ul style="list-style-type: none"> <li>— Check ribbon cable connections.</li> <li>— Ribbon cable defective.</li> <li>— Relay board, low voltage, connector defective.</li> <li>— Display board connector defective.</li> <li>— Software may need to be updated again.</li> </ul>
<b>E101</b>	DB is not equal to RB version. Error generated by RB.	Software update may have failed.	<ul style="list-style-type: none"> <li>— Check ribbon cable connections.</li> <li>— Ribbon cable defective.</li> <li>— Relay board, low voltage, connector defective.</li> <li>— Display board connector defective.</li> <li>— Software may need to be updated again.</li> </ul>

# INSTALLATION

## CombiTouch MOTOR CONTROL ERROR CODES

Type of Error	Indication	Release of Error
Undervoltage	LED flashing sequence, with 1 flash per period.	Voltage of intermediate circuit is less than 250V
Overvoltage	LED flashing sequence, with 2 flashes per period.	Voltage of intermediate circuit exceeds 445V
Excess Temperature	LED flashing sequence, with 3 flashes per period.	Temperature sensor in the power unit is more than 93°C
Overcurrent	LED flashing sequence, with 4 flashes per period.	Blocked motor, detected by current peak monitoring from 900 rpm rotating field
Overcurrent	LED flashing sequence, with 5 flashes per period.	Intermediate circuit current exceeds 4.0A
Short-circuit	LED flashing sequence, with 6 flashes per period.	Release of interrupt at intermediate circuit current larger than 53A
Power on	LED flashing sequence, with 7 flashes per period.	Effective mains voltage does not correspond to jumper setting 115V/230V
Watchdog	LED flashing sequence, with 8 flashes per period.	Watchdog of the microcontroller released, program crash

# INSTALLATION

## ERROR CODES

When the oven malfunctions, an error code will appear in the display.



**PRESS THE START ICON TO ACKNOWLEDGE THE ERROR.**

The icons that begin to flash represent operational modes that are still usable.

When the oven fault is corrected, the Combitherm will return to normal operation.

Error Code	Display Shows	Model		Mode			
		ES	ESG ESI	Steam	Combination	Convection	Retherm
<b>E01</b>	Low Water Boiler	Yes	No	No	No	To 365°F/185°C	No
<b>E02</b>	Control Temp High	Yes	Yes	No	No	No	No
<b>E03</b>	Fan Motor Error	Yes	Yes	No	No	No	No
<b>E04</b>	Fan Motor 2 Error	Yes	Yes	No	No	No	No
<b>E11</b>	Convection Temperature High	Yes	Yes	BOILER UNITS ONLY	No	No	No
<b>E13</b>	Boiler Temperature High	Yes	No	No	No	Yes	No
<b>E15</b>	Condenser Temperature High	Yes	Yes	No	No	To 356°F/180°C	No
<b>E20</b>	B11 Core Temperature Probe Single Point Fault - HACCP only	Yes	Yes	No	No	No	No
<b>E21</b>	N6 Cavity Probe Fault	Yes	Yes	BOILER UNITS ONLY	No	No	No
<b>E22</b>	B10 Core Temp Probe Fault	Yes	Yes	BY TIME ONLY	BY TIME ONLY	BY TIME ONLY	BY TIME ONLY
<b>E23</b>	B4 Boiler Probe Fault	Yes	No	No	No	No	No
<b>E24</b>	B5 Bypass Probe Fault	Yes	Yes	No	No	Yes	No
<b>E25</b>	B3 Condenser Probe Fault	Yes	Yes	Yes	No	To 356°F/180°C	No
<b>E26</b>	N8 Boiler Safety Temperature Probe Fault	Yes	No	No	No	No	No
<b>E27</b>	Boiler Element Temperature High	Yes	No	No	No	Yes	No
<b>E34</b>	Steam Generator Drain Pump Fault	Yes	No	No	No	No	No
<b>E36</b>	Steam Temperature High	Yes	No	No	No	Yes	No
<b>E51</b>	No Water in Boiler	Yes	No	No	No	Yes	No
<b>E53</b>	Fan Motor High Temperature	Yes	Yes	No	No	No	No
<b>E54</b>	Fan Motor 2 High Temperature	Yes	Yes	No	No	No	No
<b>E55</b>	Vent Not Open	Yes	Yes	Yes (NO BROWNING)	Yes (NO BROWNING)	Yes (NO BROWNING)	Yes (NO BROWNING)
<b>E57</b>	No Rinse Water	Yes	Yes	Yes	Yes	Yes	Yes
<b>E93</b>	Communication Error FROM Display Board	Yes	Yes	No	No	No	No
<b>E94</b>	Communication Error TO Display Board	Yes	Yes	No	No	No	No

# INSTALLATION

## VENTLESS HOOD OPTION



The Ventless Hood option is factory installed directly on the top of the Alto-Shaam Combitherm oven. The hood is designed to vent clean air back into the kitchen, filtering vapors and grease. A high-power fan draws steam and fumes into the hood intake and out the top surface exhaust vent. Fumes and vapors are circulated through filters draining the condensation through a drain at the rear of the hood. An activated charcoal filter cleans the air before venting it out the top of the hood.

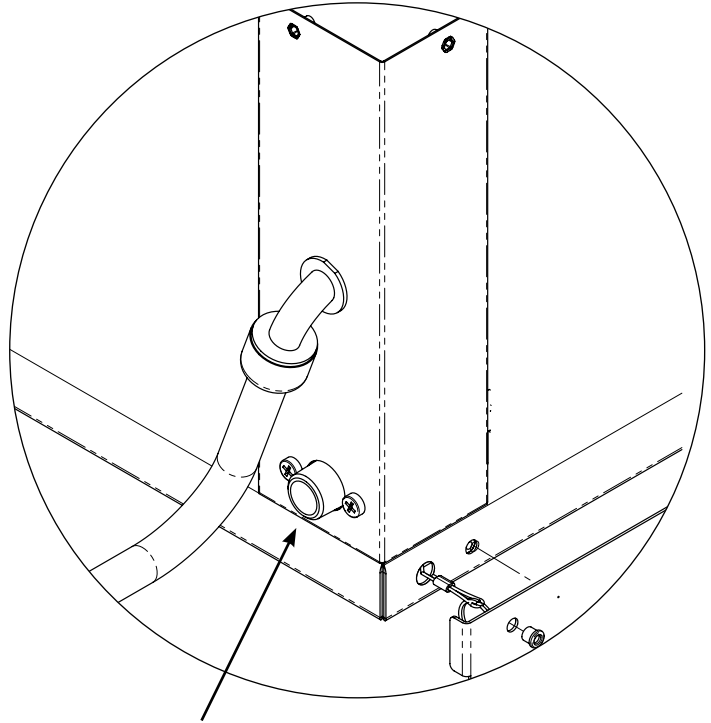

### CONDENSATE DRAIN

A ventless hood condensate drain line to the floor drain must be installed. The 3/4" NPT thread connection is found at the back of the hood. The drain line must always be a positive gradient away from the Combitherm.



### FILTER DOOR LATCH

Using a coin or screwdriver, turn to open; reverse procedure to close and latch.

Hood and oven will not operate unless this is closed properly.

# INSTALLATION

## VENTLESS HOOD OPTION

### TOP EXHAUST VENT

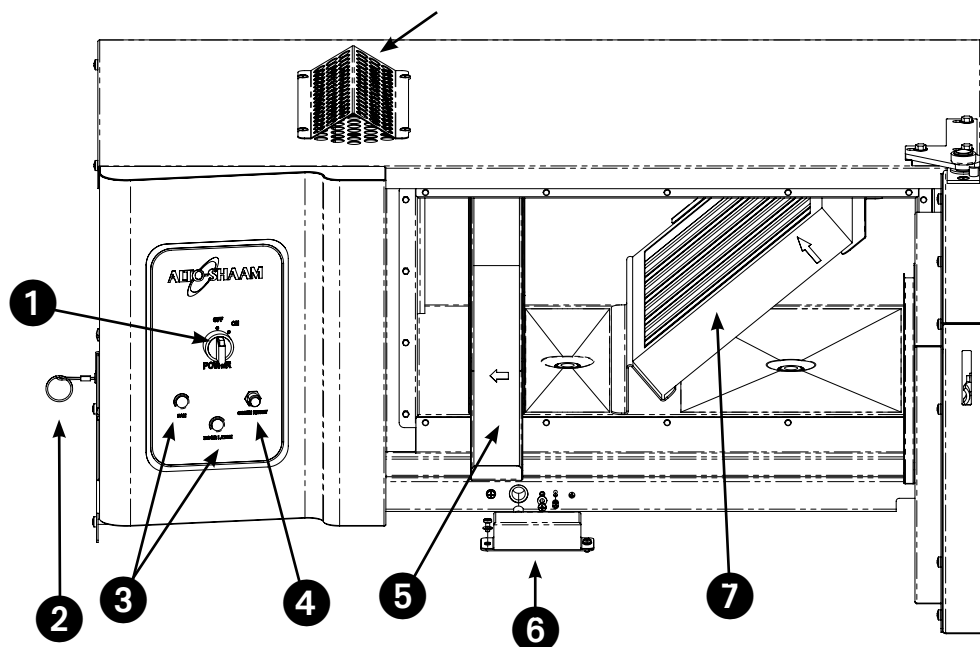

### OPERATION

- 1 Turn the ventless hood power knob "ON".
- 2 Wait five seconds, then press the "COMBI RESET" button.
- 3 Turn the Combitherm oven power "ON".

#### 1 Ventless Hood Power Knob

**2 Emergency Latch Release:** This release is to be used *ONLY* if the timed latch mechanism is not working or in the event of a power outage. Repeated use of the emergency release may damage the switching mechanism.

**3 Indicator Lights:** If the indicator lights do not illuminate, the filters may be missing or not properly aligned. Check them for proper positioning. Ventless hood and oven will not operate unless the hood is closed properly.

**4 Combi Reset Button:** The reset has to be used if the Combitherm oven is turned on before the hood or if the hood was opened. It resets the pressure switch circuit and provides power to the Combi control circuit. This switch must also be used to reset hood controls after any problem with the filters, or the improper latching of the ventless hood door.

**5 Charcoal Filter:** The charcoal filter should be inspected for contaminant's on a regular basis. Replacement must be made at a minimum of three month intervals — more often if heavy contaminant's are visible or if the filter no longer controls odors.

To remove the filter, pull and slide out while holding the bottom housing. When replacing the filter, make certain the air flow arrow(s)

point toward the hood fan, and that the filter is replaced in the three-sided metal frame provided with the hood.

FI-24114 (VHes-5); FI-24102 (VHes-10)

**6 Timed Latching Mechanism:** In order to evacuate steam and grease-laden air from the oven interior, this mechanism prevents the operator from fully opening the oven door for 25 seconds to one minute. The mechanism automatically disengages at the end of a pre-set time allowing full door extension.

**7 Grease Filter:** Cleaning frequency should be based on oven usage with a maximum of two weeks between cleaning if the oven is used for non-grease laden products or steam applications only. Grease laden products require cleaning frequency of at least once a week.

Remove the grease filter by pulling it straight out of the housing. Place the filter in the dishwasher or wash separately by placing in hot, soapy water until all grease and particles have been removed. Rinse thoroughly. Allow the filter to air dry before reinstalling.

To replace the grease filter, the air flow arrow on the filter casing should be pointing toward the hood fan.

FI-24113 (VHes-5); FI-23062 (VHes-10)

# ORIGINAL EQUIPMENT LIMITED WARRANTY

Alto-Shaam, Inc. warrants to the original purchaser that any original part that is found to be defective in material or workmanship will, at Alto-Shaam's option, subject to provisions hereinafter stated, be replaced with a new or rebuilt part.

The labor warranty remains in effect one (1) year from installation or fifteen (15) months from the shipping date, whichever occurs first. Alto-Shaam will bear normal labor charges performed by an authorized Alto-Shaam service agent during standard business hours, and excluding overtime, holiday rates or any additional fees.

The parts warranty remains in effect for one (1) year from installation or fifteen (15) months from the shipping date, whichever occurs first.

## THIS WARRANTY DOES NOT APPLY TO:

1. Replacement of light bulbs, door gaskets, and/or the replacement of glass due to damage of any kind.
2. Equipment damage caused by accident, shipping, improper installation or alteration.
3. Steam generator or steam generating system damage as a result of inadequate routine maintenance and cleaning. Required maintenance and cleaning of steam generating equipment is the responsibility of the owner/operator.
4. Equipment used under conditions of abuse, misuse, carelessness or abnormal conditions including, but not limited to, equipment subjected to harsh or inappropriate chemicals including, but not limited to, compounds containing chlorine, chlorides or quaternary salts, or equipment with missing or altered serial numbers.
5. Equipment that uses water must meet Alto-Shaam's minimum water quality standards as shown below. **USE OF WATER NOT MEETING ALTO-SHAAM'S MINIMUM WATER QUALITY STANDARDS WILL VOID THIS WARRANTY.**

Water quality and required maintenance of steam generating equipment is the responsibility of the owner/operator. The installation and use of Alto-Shaam's CombiGuard™ Water Filtration System is highly recommended.

<b>ALTO-SHAAM COMBITHERM WATER QUALITY MINIMUM STANDARDS</b>	
<b>CONTAMINANT</b>	<b>INLET WATER REQUIREMENTS (UNTREATED WATER)</b>
Free Chlorine	Less than 0.1 ppm (mg/L)
Hardness	Less than 3 gpg (52 ppm)
Chloride	Less than 30 ppm (mg/L)
pH	7.0 to 8.5
Alkalinity	Less than 50 ppm (mg/L)
Silica	Less than 12 ppm (mg/L)
Total Dissolved Solids (tds)	Less than 60 ppm

6. Damage caused by use of any cleaning agent other than Alto-Shaam's Combitherm® Oven Cleaner including, but not limited to, damage due to chlorine, bleach, quaternary salts, scouring powders or other harmful chemicals. Use of Alto-Shaam's Combitherm Cleaner on Combitherm ovens is highly recommended.
7. Any losses or damage resulting from malfunction, including loss of product, food product, revenue, or other consequential or incidental damages of any kind.
8. Equipment modified in any manner from original model, substitution of parts other than factory authorized parts, removal of any parts including legs, or addition of any parts.

THIS WARRANTY IS EXCLUSIVE AND IS IN LIEU OF ALL OTHER WARRANTIES, EXPRESSED OR IMPLIED, INCLUDING THE IMPLIED WARRANTIES OF MERCHANTABILITY AND FITNESS FOR A PARTICULAR PURPOSE. IN NO EVENT SHALL ALTO-SHAAM BE LIABLE FOR LOSS OF USE, LOSS OF REVENUE OR PROFIT, OR LOSS OF PRODUCT, OR FOR ANY INDIRECT, INCIDENTAL OR CONSEQUENTIAL DAMAGES.

No person except an officer of Alto-Shaam, Inc. is authorized to modify this warranty or to incur on behalf of Alto-Shaam any other obligation or liability in connection with Alto-Shaam equipment.

Warranty effective November 1, 2011



# TRANSPORTATION DAMAGE AND CLAIMS



All Alto-Shaam equipment is sold F.O.B. shipping point, and when accepted by the carrier, such shipments become the property of the consignee.

Should damage occur in shipment, it is a matter between the carrier and the consignee. In such cases, the carrier is assumed to be responsible for the safe delivery of the merchandise, unless negligence can be established on the part of the shipper.

1. Make an immediate inspection while the equipment is still in the truck or immediately after it is moved to the receiving area. Do not wait until after the material is moved to a storage area.
2. Do not sign a delivery receipt or a freight bill until you have made a proper count and inspection of all merchandise received.
3. Note all damage to packages directly on the carrier's delivery receipt.
4. Make certain the driver signs this receipt. If he refuses to sign, make a notation of this refusal on the receipt.
5. If the driver refuses to allow inspection, write the following on the delivery receipt:

*Driver refuses to allow inspection of containers for visible damage.*

6. Telephone the carrier's office immediately upon finding damage, and request an inspection. Mail a written confirmation of the time, date, and the person called.
7. Save any packages and packing material for further inspection by the carrier.
8. Promptly file a written claim with the carrier and attach copies of all supporting paperwork.

We will continue our policy of assisting our customers in collecting claims which have been properly filed and actively pursued. We cannot, however, file any damage claims for you, assume the responsibility of any claims, or accept deductions in payment for such claims.

---

---

RECORD THE MODEL AND SERIAL NUMBER OF THE APPLIANCE FOR EASY REFERENCE. ALWAYS REFER TO BOTH MODEL AND SERIAL NUMBER IN ANY CONTACT WITH ALTO-SHAAM REGARDING THIS APPLIANCE.

Model: \_\_\_\_\_

Serial Number: \_\_\_\_\_

Date Installed: \_\_\_\_\_

Voltage: \_\_\_\_\_

Purchased From: \_\_\_\_\_

\_\_\_\_\_  
\_\_\_\_\_



Alto-Shaam has established a twenty-four hour emergency service call center to offer immediate customer access to a local authorized service agency outside of standard business hours. The emergency service access is provided exclusively for Alto-Shaam equipment and is available throughout the United States through the use of Alto-Shaam's toll-free number. Emergency service access is available seven days a week including holidays.