

C156-F047-01EN

**MDG3230UB  
OPTICAL DISK DRIVES  
MAINTENANCE MANUAL**

# FOR SAFE OPERATION

## Handling of This Manual

This manual contains important information for using this product. Read thoroughly before using the product. Use this product only after thoroughly reading and understanding especially the section "Important Alert Items" in this manual. Keep this manual handy, and keep it carefully.

FUJITSU makes every effort to prevent users and bystanders from being injured or from suffering damage to their property. Use the product according to this manual.

This product is designed and manufactured for use in standard applications such as office work, personal devices and household appliances. This product is not intended for special uses (atomic controls, aeronautic or space systems, mass transport vehicle operating controls, medical devices for life support, or weapons firing controls) where particularly high reliability requirements exist, where the pertinent levels of safety are not guaranteed, or where a failure or operational error could threaten a life or cause a physical injury (hereafter referred to as "mission-critical" use). Customers considering the use of these products for mission-critical applications must have safety-assurance measures in place beforehand. Moreover, they are requested to consult our sales representative before embarking on such specialized use.

First Edition April 2002

The contents of this manual may be revised without prior notice.

The contents of this manual shall not be disclosed in any way or reproduced in any media without the express written permission of Fujitsu Limited.

All Rights Reserved, Copyright © FUJITSU LIMITED 2002

# Revision History

(1/1)

Edition	Date	Revised section (*1) (Added/Deleted/Altered)	Details
01	2002-4-25	—	—

\*1 Section(s) with asterisk (\*) refer to the previous edition when those were deleted.

This page is intentionally left blank.

# Preface

This document describes procedures for maintenance of the MDG3230UB (DynaMO 2300U2), a 3.5-inch magneto-optical disk drive. The MDG3230UB (referred to as "the product" hereafter) is provided with the MCJ3230UB 3.5-inch magneto-optical disk drive unit (referred to as "MO drive" hereafter). The components are built in a case designed specifically for the product.

Refer to related manuals for operations other than maintenance and for explanation about an MO drive.

The organization of this manual, related reference manual and conventions for alert messages follow.

## Overview of Manual

This manual consists of the following six chapters, glossary, and abbreviation:

### **Chapter 1 Overview**

This chapter introduces the MDG3230UB MO disk drive. The chapter describes the system features and outline of maintenance.

### **Chapter 2 Diagnosis and Maintenance**

This chapter describes maintenance conditions, diagnosis methods, failure analysis procedures, and system updating procedures of the MDG3230UB MO disk drive.

### **Chapter 3 Troubleshooting**

This chapter describes troubleshooting of a system connected to a Macintosh G3 and Windows computer.

### **Chapter 4 Returning Repaired Unit**

This section describes procedures for unpacking, packing, transporting, and storing the MDG3230UB MO disk drive.

### **Chapter 5 Cleaning**

## CONVENTIONS USED IN THIS MANUAL

### Conventions for Alert Messages

This manual uses the following conventions to show the alert messages. An alert message consists of an alert signal and alert statements. The alert signal consists of an alert symbol and a signal word or just a signal word.

The following are the alert signals and their meanings:



This indicates a hazardous situation *likely* to result in *serious personal injury* if the user does not perform the procedure correctly.



This indicates a hazardous situation *could* result in *serious personal injury* if the user does not perform the procedure correctly.



This indicates a hazardous situation *could* result in *minor or moderate personal injury* if the user does not perform the procedure correctly. This alert signal also indicates that damages to the product or other property, *may* occur if the user does not perform the product correctly.

**IMPORTANT**

This indicates information that could help the user use the product more efficiently.

In the text, the alert signal is centered, followed below by the indented message. A wider line space precedes and follows the alert message to show where the alert message begins and ends. The following is an example:

(Example)

### **IMPORTANT**

*Fujitsu issues a Change Request/Notification regarding post-factory-shipment revision number changes. When the user changes the version number, the revision-number label should be updated as described above after the change is applied. The main alert messages in the text are also listed in the “Important Alert Items.”*

### **Attention**

Please forward any comments you may have regarding this manual.

To make this manual easier for users to understand, opinions from readers are needed. Please write your opinions or requests on the Comment at the back of this manual and forward it to the address described in the sheet.

This page is intentionally left blank.



# Important Alert Items

## Important Alert Messages

The important alert messages in this manual are as follows:



A hazardous situation *could* result in *minor* or *moderate personal injury* if the user does not perform the procedure correctly. Also, damage to the product or other property, *may* occur if the user does not perform the procedure correctly.

Task	Alert message	Page
Device Damage	Be sure to use the dedicated head cleaner described above.	5-1
Device damage	Use the cleaner and cleaning cloth specified in Table 5.2. If other than the specified items is used, disk media surface may be damaged.	5-5
Device damage	Do not use this cleaning kit for the floppy disk or the optical disk cartridge used for other optical disk drive.	5-5
Disk media damage	Clean the cartridge at clean place. Put a disposable groves at cleaning so that the fingerprint does not put on the disk media (recommendation).	5-5
Device Damage	When setting the optical disk cartridge in the setting case, neither apply strong shock nor push it forcibly.	5-6
Damage for data medium	In case of contact, immediately flush eyes with water.	5-7

This page is intentionally left blank.

MANUAL ORGANIZATION

MDG3230UB  
OPTICAL DISK DRIVES  
MAINTENANCE MANUAL  
(C156-F047)  
<This manual>

1. OVERVIEW
2. DIAGNOSIS AND MAINTENANCE
3. TROUBLESHOOTING
4. RETURNING REPAIRED UNIT
5. CLEANING

MCJ3230UB  
OPTICAL DISK DRIVES  
PRODUCT MANUAL  
(C156-E232)

1. GENERAL DESCRIPTION
2. SPECIFICATIONS
3. INSTALLATION REQUIREMENTS
4. HOST INTERFACE
5. OPERATION AND CLEANING
6. DIAGNOSTICS AND MAINTENANCE

## REFERENCED STANDARDS

The product specifications and functions described in this manual conform to the following standards:

Specification (document) number	Name	Concerned organization
	Universal Serial Bus Specification, Revision 2.0	USB implementers Forum
	Universal Serial Bus Mass Storage Class Bulk-Only Transport, Revision 1.0	USB implementers Forum
	Universal Serial Bus Mass Storage Class Specification Overview, Revision 1.0	USB implementers Forum
ISO/IEC 10090	90mm Optical Disk Cartridges, rewritable and read only, for data interchange.	ISO/IEC (*1)
ISO/IEC 13963	Data Interchange on 90mm Optical Disk cartridges Capacity: 230 megabytes per cartridge.	ISO/IEC (*1)
ISO/IEC 15041	Data Interchange on 90mm Optical Disk Cartridges Capacity: 640 megabytes per cartridge.	ISO/IEC JTC1 (*1)
Cherry Book Version 1.0	GIGAMO 1.3GB 90mm Magneto-Optical Disk System.	FUJITSU LIMITED SONY CORPORATION
Cherry Book Version 2.0	GIGAMO 2.3GB 90mm Magneto-Optical Disk System.	FUJITSU LIMITED SONY CORPORATION

\*1

ISO= International Organization for Standardization  
 IEC= International Electrical for Commission  
 JTC1= Joint Technical Committee 1

# Contents

<b>CHAPTER 1</b>	<b>OVERVIEW.....</b>	<b>1-1</b>
1.1	Description	1-1
1.2	Maintenance Method	1-1
<b>CHAPTER 2</b>	<b>DIAGNOSIS AND MAINTENANCE.....</b>	<b>2-1</b>
2.1	Maintenance Conditions	2-1
2.2	Diagnosis	2-2
2.3	Troubleshooting Method	2-2
2.4	Unit Version Number	2-3
<b>CHAPTER 3</b>	<b>TROUBLESHOOTING.....</b>	<b>3-1</b>
3.1	For Macintosh Users	3-1
3.2	For Windows Users	3-2
<b>CHAPTER 4</b>	<b>RETURNING REPAIRED UNIT.....</b>	<b>4-1</b>
4.1	Unpacking	4-1
4.2	Packing	4-1
4.3	Transportation	4-3
4.4	Storage	4-3
<b>CHAPTER 5</b>	<b>CLEANING.....</b>	<b>5-1</b>
5.1	Cleaning Drive	5-1

5.2	MO Cartridge Operation	5-2
5.2.1	MO cartridge	5-2
5.2.2	Write protect tab	5-3
5.2.3	Notes	5-3
5.3	Cleaning Cartridge	5-4
5.3.1	Cleaning tool	5-4
5.3.2	Cleaning procedure	5-5

## Illustrations

### Figures

Figure 2.1	Unit revision number label	2-3
Figure 2.2	Unit revision-number indication	2-4
Figure 4.1	Packing and handling of MDG3230UB	4-2
Figure 5.1	MO cartridge	5-2
Figure 5.2	Write protect tab	5-3
Figure 5.3	Cleaning procedure (1)	5-6
Figure 5.4	Cleaning procedure (2)	5-6
Figure 5.5	Cleaning procedure (3)	5-7
Figure 5.6	Cleaning procedure (4)	5-8

### Tables

Table 5.1	Head cleaner	5-1
Table 5.2	Cleaning kit	5-4
Table 5.3	Packaged items (cleaning kit)	5-4
Table 5.4	Cleaning kit (supplement)	5-5

This page is intentionally left blank



# CHAPTER 1 OVERVIEW

1.1	Description
1.2	Maintenance Method

## 1.1 Description

This product assumes that repair operations are performed in a factory.

On-site replacement of an MO drive unit.

## 1.2 Maintenance Method

In the field, a faulty section should be isolated among the following four:

- Main unit
- Cable
- Media
- AC adapter

If a main unit is faulty, the product should be sent to Fujitsu for repairing in a factory.

This page is intentionally left blank

# CHAPTER 2 DIAGNOSIS AND MAINTENANCE

2.1	Maintenance Condition
2.2	Diagnosis
2.3	Troubleshooting Method
2.4	Unit Version Number

## 2.1 Maintenance Conditions

The following conditions are applicable to on-site maintenance:

(1) Preventive maintenance

No preventive maintenance is required.

(2) Service life

The internal MO drive does not require and overhaul during the first five years after installation, provided that the customer cleans the disks and optical parts, and handles them appropriately.

(3) Service system and repair

Fujitsu has a service system and repair facility for MO drives. Customers should submit information required for the replacement or repair of an MO drive to the responsible person in Fujitsu. The following information is usually required:

- a) Model No. of the internal MO drive, part number (P/N), unit version number, serial number (S/N), and manufacturing date
- b) Fault occurrence status
  - Date of failure occurrence
  - System configuration
  - Environmental conditions (temperature and humidity, voltage, etc.)
- c) Fault history
- d) Fault details
  - Failure outline
  - Error messages

- Other fault analysis information

## 2.2 Diagnosis

The MO drive has an initial self-diagnosis function, which checks the normal basic operation of the MO drive.

- Initial self-diagnosis function

When the power is turned on, the MO drive executes initial self-diagnosis, which includes a basic test of hardware functions.

If an error is detected during self-diagnosis, the LED on the front panel of the MO drive blinks. The status can be cleared by turning the power off and then on again. When this status is cleared, the MO drive re-executes the initial self-diagnosis.

## 2.3 Troubleshooting Method

The system-level troubleshooting steps listed below are performed for determining if the fault is caused by an MO drive unit or caused by a system. The steps should be performed by customers on-site.

Item	Recommended procedure
MO cartridge	Check that a recommended MO cartridge is loaded and the surface of the disk is free from dirt or scratches.
AC adapter	Check whether power indicator on the device side has lighted up before connecting the device between host computer with the USB cable.
Interface cable connection	Check that the interface cable is correctly connected to the MO drive.
System cable	Check that all cables in the system are correctly connected.
System diagnosis test	Execute the system level diagnostic routines given in the host computer manual to further isolate the fault, if possible.
Intermittent or indefinite error	Replace the MO drive if possible. If the faulty condition continues after the replacement, the fault will not be caused by the MO drive.  Refer to the provided hardware and software manuals about the system further, for clues of identifying cause of the failure.

## 2.4 Unit Version Number

If a unit version number should be changed on site, take the following steps:

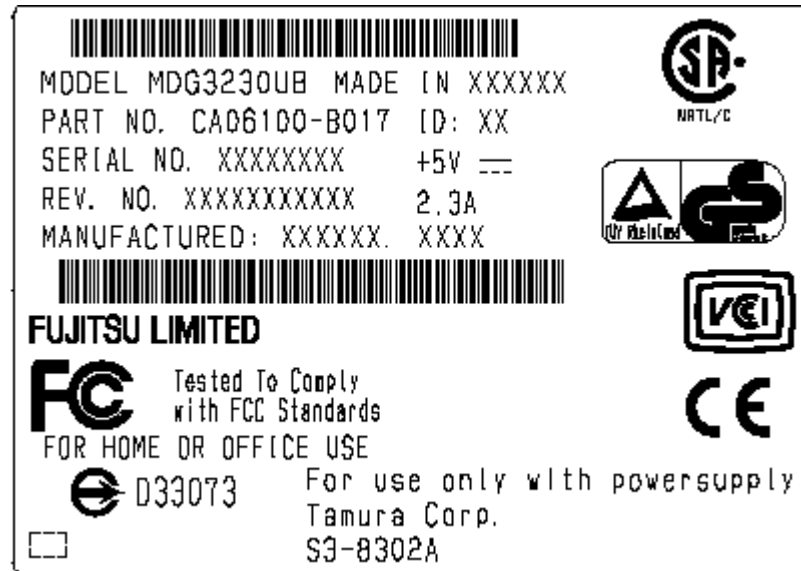

**Figure 2.1 Unit revision number label**

(1) Revision-number display at shipment

The unit version number of an MO drive is indicated by crossing out unnecessary number with an equal sign (=) in the corresponding alphanumeric character string on the label. (See Figure 2.2.)

(2) Revision number changes in the field

When the revision number is changed following part replacement or other modifications, the applicable level is indicated by the corresponding number enclosed with a circle in the corresponding number string. (See Figure 2.2.)

### IMPORTANT

*Fujitsu issues a Change Request/Notification regarding post-factory-shipment revision number changes. When the user changes the version number, the revision-number label should be updated as described above after the change is applied.*

Revision number indicated on shipment

REV. NO. A 0 1 2 3 4 5 6 7 8 9 ⇒ Revision A2

Revision number changed on site

REV. NO. A 0 1 2 ③ 4 5 6 7 8 9 ⇒ Revision A3

**Remarks:**

A is stamped in the revision-number indication

**Figure 2.2 Unit revision-number indication**

# CHAPTER 3 TROUBLESHOOTING

- |     |                     |
|-----|---------------------|
| 3.1 | For Macintosh Users |
| 3.2 | For Windows Users   |

## 3.1 For Macintosh Users

The following describes troubleshooting of the DynaMO MO drive connected to a Macintosh computer.

### **An inserted MO disk is not mounted on desktop.**

- Is the MO disk drive properly connected to the Macintosh computer?

Verify that the MO disk drive and the Macintosh computer are connected to each other properly. If two or more devices are connected to one another, also check that all other devices are connected properly.

- Has a disk been initialized in proper format?

An MO disk formatted improperly cannot be mounted on desktop. Initialize the disk in a format appropriate for the product.

- Has a disk been initialized?

An MO disk that has not been initialized cannot be mounted on desktop. Initialize the MO disk as described in the User's Manual.

### **An MO disk cannot be dismounted.**

- Has an MO disk icon on desktop been thrown away to "Trash" box?

On a Macintosh computer, an MO disk is dismounted by throwing an MO disk icon away to "Trash" icon (by dragging and dropping an MO icon onto "Trash" icon). Usually, pressing the eject button does not dismount an MO disk.

## 3.2 For Windows Users

The following describes troubleshooting of the DynaMO MO drive connected to a Windows computer.

### **MO drive is not recognized/ MO drive icon does not appear on the desktop.**

- Is the MO disk drive properly connected to your PC?

Verify that the MO disk drive and the PC are connected to each other properly.

- Is AC adapter is connected?

If AC adapter is not connected to MO disk drive, disconnect the MO drive from your PC, connect the AC adapter, and then re-connect MO disk drive to your PC.

### **MO disk cannot be used properly.**

- Has the device driver been installed?

If the device drivers have not been installed in Windows 98 and Windows 98 Second Edition, install the device drivers following the steps described in the User's Manual.

- Is AC adapter is connected?

If the AC adapter is not connected to the MO disk drive, disconnect the MO drive from your PC, connect the AC adapter, and then re-connect MO disk drive to your PC.



# CHAPTER 4 RETURNING REPAIRED UNIT

4.1	Unpacking
4.2	Packing
4.3	Transportation
4.4	Storage

## 4.1 Unpacking

The following provides notes on unpacking a replacing MO disk drive:

- Ensure flat and level working space, and pay attention to indication of upside and downside on a package box. Avoid placing the unit directly on a firm desk, etc. Handle a unit on a soft material such as rubber mat, etc.
- When removing cushions, pay attention not to strain an MO disk drive.
- When taking a unit out of an anti-static plastic bag, pay extra attention not to strain printed circuit surface and interface connectors.
- If an MO disk drive is moved into a place where room temperature changes by 10 degrees Celsius, leave the unit packed for more than 2 hours after moving, for avoiding condensation.

## 4.2 Packing

The following provides notes on packing a replaced MO disk drive:

- For packing, use the same cushions and a box as those provided upon delivery of a unit. If the same cushions and a box are unavailable, use a box with cushions that do not give physical shock to an MO disk drive.
- Pack an MO disk drive with an MO cartridge removed (with the carriage locked).
- When packing an MO disk drive, provide sufficient protection against damage on printed circuit surface and interface connectors.
- Put an MO disk drive into an anti-static plastic bag with desiccant.
- Provide plainly visible signs indicating "THIS SIDE UP" and "HANDLE WITH CARE" outside a box.
- Other provided materials (AC adapter, cable, media, etc.) should be kept separately. Do not pack them with an MO disk drive.

Figure 4.1 shows outline of packing procedures. Shapes and materials of cushions may be different from those used with the same functions.

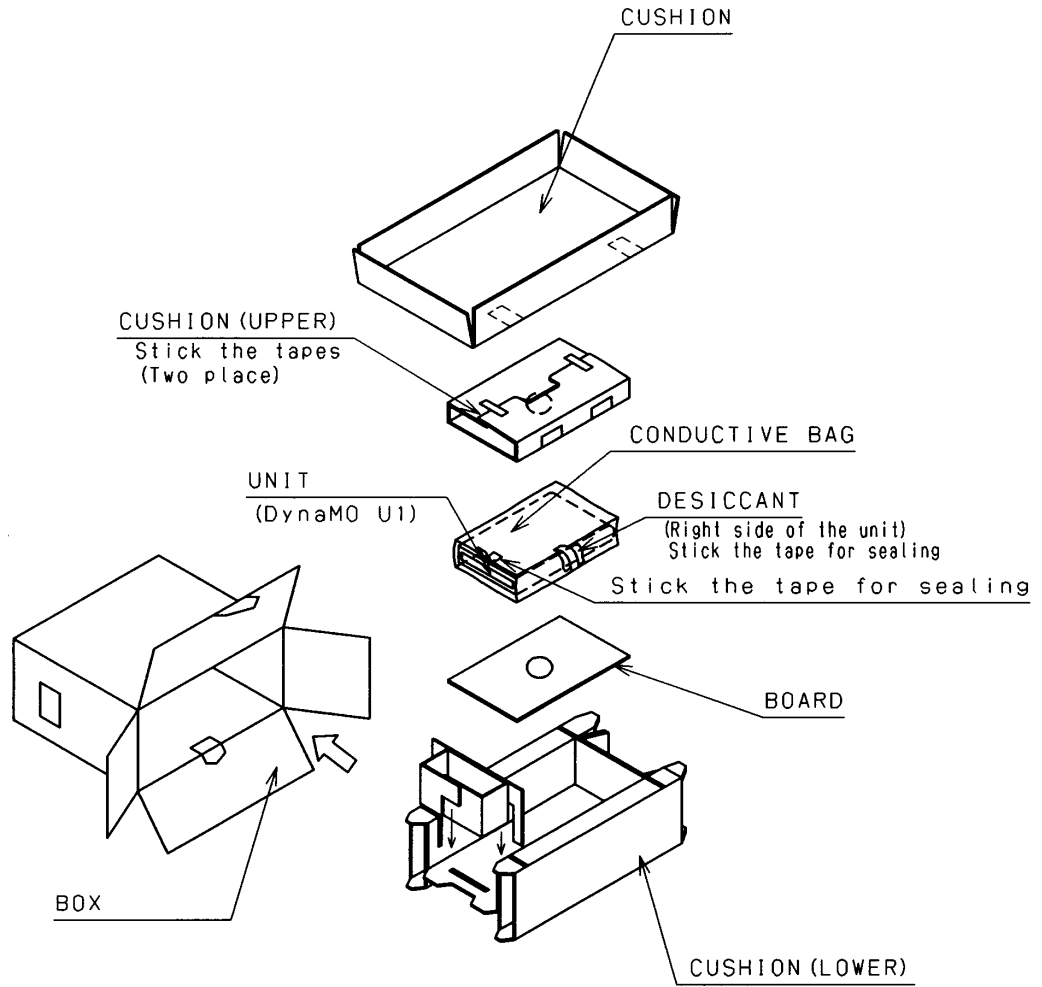

**Figure 4.1 Packing and handling of MDG3230UB**

### 4.3 Transportation

The following provides notes on transporting an MO disk drive:

- An MO disk drive must be transported in packed status in proper package. A unit must not be turned over; always keep the top side up.
- After unpacking, transportation of a drive must be limited to short distance, avoiding shocks and vibrations using cushion. During transportation after unpacking, it is recommended that an MO disk drive should be kept level.

### 4.4 Storage

The following provides notes on storing an MO disk drive:

- Moisture-proof packing must be used for storage.
- Drastic temperature changes must be avoided in storage environment for preventing condensation.

This page is intentionally left blank

# CHAPTER 5 CLEANING

5.1	Cleaning Drive
5.2	MO Cartridge Operation
5.3	Cleaning Cartridge

This chapter describes how to clean internal MO drive and the MO cartridge.

## 5.1 Cleaning Drive

When a dust or smoke of cigarette is stained to the lens actuator, a performance of whole drive may be down. Clean the lens actuator periodically using following head cleaner.

**Note:**

Cleaning period differs depending on the installation condition. Usually, cleaning period is once a three months.

**Table 5.1 Head cleaner**

Part name	Order number
Head cleaner	CA90002-C980

(1) Cleaning method

Clean the head actuator with following method.

1. Turn on the power of the drive.
2. Insert the head cleaner.
3. The head cleaner is automatically loaded and the cleaning brush disk in the head cleaner is rotated to clean the lens.
4. When the cleaning is finished, the head cleaner is automatically unloaded. (cleaning time: 15 seconds)



**Device Damage:** Be sure to use the dedicated head cleaner described above.

### **IMPORTANT**

Check the cleaning brush state by opening the shutter of the head cleaner. If the tip of brush is open, used new head cleaner.

## **5.2 MO Cartridge Operation**

### **5.2.1 MO cartridge**

Figure 5.1 shows the MO cartridge. For operation and cleaning, users should be familiar with the parts shown in the figure.

- Shutter closed

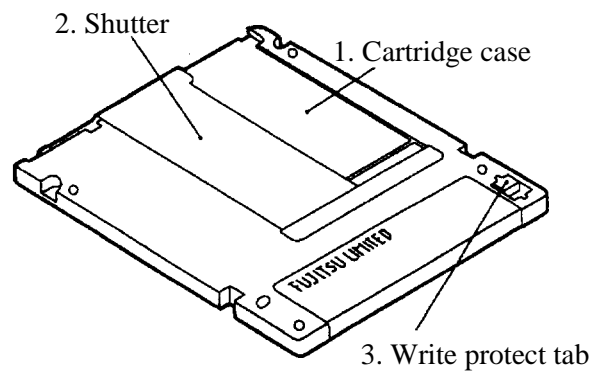

- Shutter open

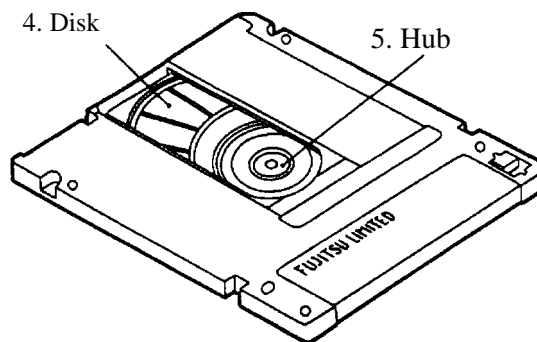
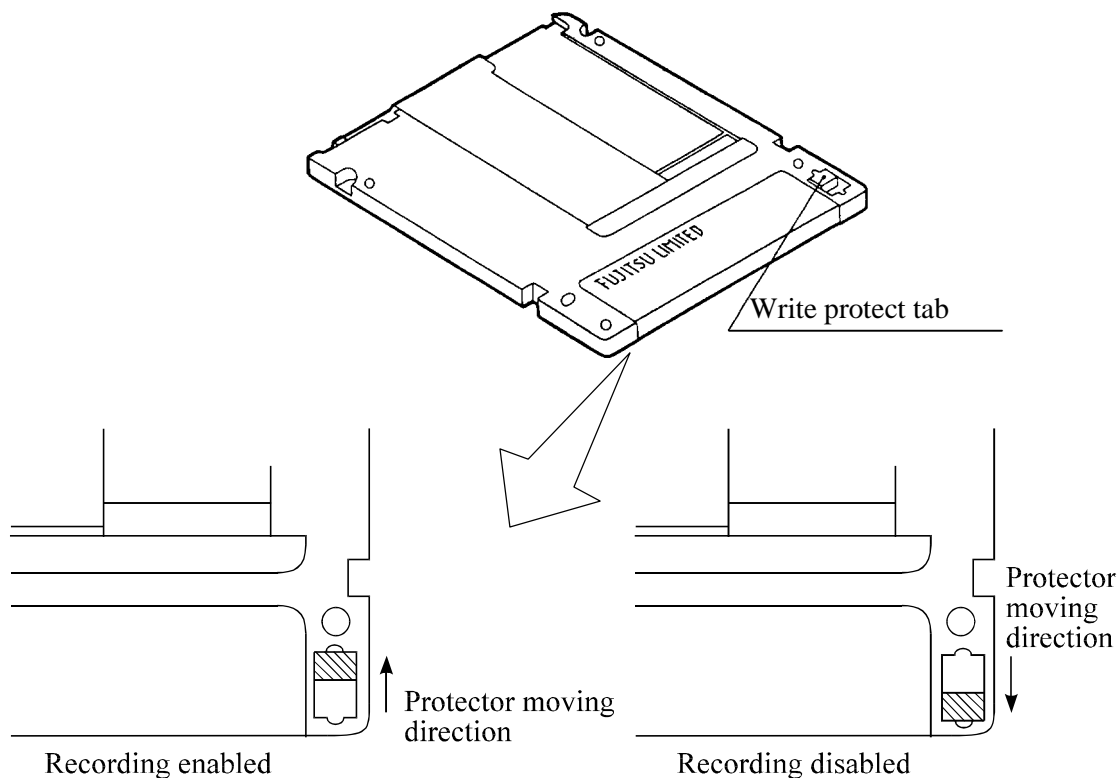

**Figure 5.1 MO cartridge**

### 5.2.2 Write protect tab

Moving the write protect tab determines whether writing is enabled. Use a fingernail to move the write protect tab completely.

Figure 5.2 shows the write protect tab location.



**Figure 5.2 Write protect tab**

### 5.2.3 Notes

To maintain the performance and reliability of the MO cartridge, keep the following points in mind when using, storing, or transporting the cartridge:

- (1) When using the cartridge:
  - Do not use the cartridge where exposed to direct sunlight or where the temperature changes sharply, the temperature is high, or the humidity is high.
  - Do not apply excessive pressure to the cartridge case or shutter. Avoid dropping the cartridge.
  - Do not use the cartridge in a dusty or smoky place.
  - Do not open the shutter or touch the disk surface.

- (2) When storing the cartridge:
  - Do not place a heavy objects on the cartridge.
  - Do not store the cartridge where exposed to direct sunlight or where the temperature changes sharply, the temperature is high, or the humidity is high.
  - Do not store the cartridge in a dusty or smoky place.
- (3) When transporting the cartridge:
  - Put the cartridge in a nylon bag to protect it from moisture.
  - Put the cartridge in a strong container and cover the cartridge with cushioning material.

### 5.3 Cleaning Cartridge

Dust or cigarette smoke particulates on the disk surface lowers the performance of the cartridge. Regularly clean the disk. The cleaning frequency depends on the drive installation environment. Determine how often the drive should be cleaned in consideration of the environment. A standard of the cleaning period is every 300 hours usage or once a 2 to 3 months.

#### 5.3.1 Cleaning tool

Use the cleaning kit to clean the disk cartridge.

##### (1) Cleaning kit

This cleaning kit is only for 90mm (3.5-inch) optical disk cartridge. Use with reading the attached operation guide well. Table 5.2 shows the order number of the cleaning kit.

**Table 5.2 Cleaning kit**

Part name	Order number
Cleaning kit	CA90003-0702

Table 5.3 shows the packaged items of the cleaning kit.

**Table 5.3 Packaged items (cleaning kit)**

Name	Contents
Setting case	1 piece
Cleaning cloth	5 pieces (70mm?70mm)
Cleanser	1 bottle (20ml)

A set of the cleanser and cleaning cloth is provided as supplement.



**Table 5.4 Cleaning kit (supplement)**

Part name	Order number
Cleaning kit (supplement)	CA90002-D901

**CAUTION**

**Device damage:** Use the cleaner and cleaning cloth specified in Table 5.2. If other than the specified items is used, disk media surface may be damaged.

## (2) Notes on usage and storage of cleaning kit

- When storing the cleanser, tighten the cap.
- As the magnet is used at revolving knob of the setting case, do not place the floppy disk near the revolving knob.
- Do not use or storage where exposed to direct sun light or near the inflammables.
- Keep out of the reach of children.

**CAUTION**

**Device damage:** Do not use this cleaning kit for the floppy disk or the optical disk cartridge used for other optical disk drive.

**5.3.2 Cleaning procedure**

Clean the disk cartridge with a following procedure.

**CAUTION**

**Disk media damage:** Clean the cartridge at clean place. Put a disposable gloves at cleaning so that the fingerprint does not put on the disk media (recommendation).

- 1) Slide the shutter completely open.

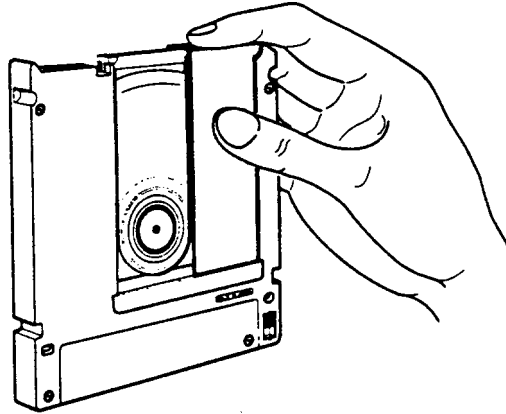
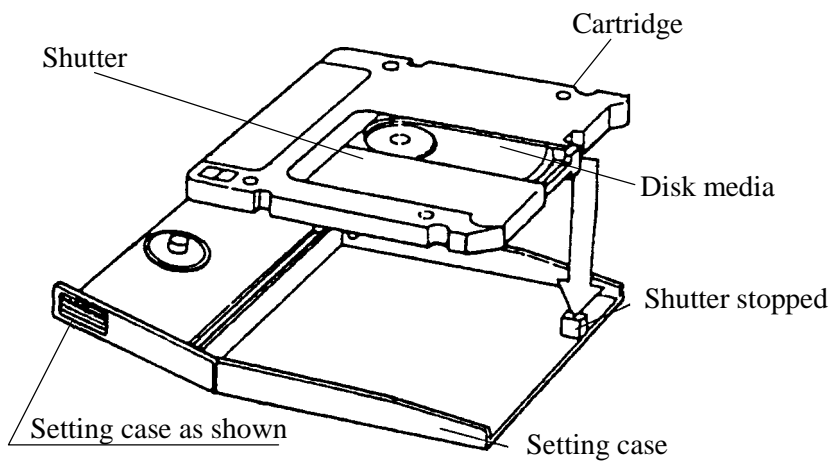

**Figure 5.3 Cleaning procedure (1)**

**CAUTION**

**Device Damage:** When setting the optical disk cartridge in the setting case, neither apply strong shock nor push it forcibly.

- 2) Set the cartridge with keeping label side down and shutter open to the shutter stopper of the setting case as shown in Figure 5.4.

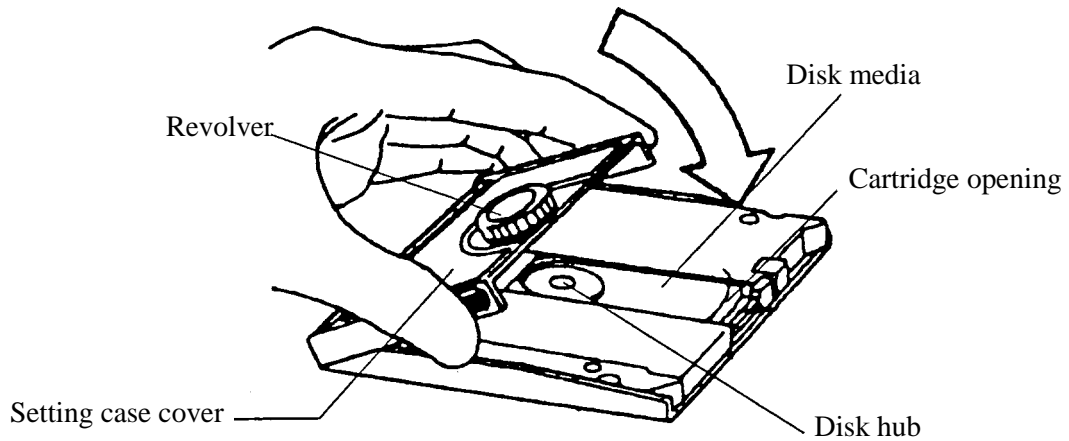

**Figure 5.4 Cleaning procedure (2)**

**Note:**

At setting the cartridge to the setting case, do not apply the heavy shock and push hardly.

- 3) Cover the cartridge with the setting case cover, then insert the spindle pin into the center hub of the cartridge.



**Figure 5.5 Cleaning procedure (3)**

- 4) Remove a slender piece that causes a defect from the disk surface at wiping the disk media.
- 5) Moisten the cleaning cloth with a few drops of cleanser.

**CAUTION**

**Damage for data medium:** In case of contact, immediately flush eyes with water.

- 6) Wipe the disk surface from the hub outward.

- 7) Turn the revolving knob, then wipe the disk surface.

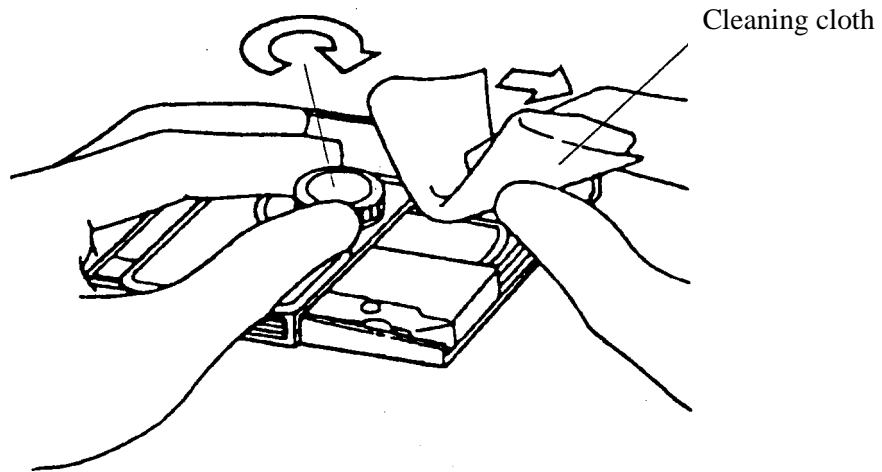

**Figure 5.6 Cleaning procedure (4)**

- 8) If the excess cleanser remains on the disk surface, wipe out with the cleaning cloth.

Comments concerning this manual can be directed to one of the following addresses:

**FUJITSU LIMITED**

Storage Products Group  
4-1-1 Kamikodanaka, Nakahara-ku, Kawasaki,  
211-8588, Japan  
TEL: 81-44-754-2130  
FAX: 81-44-754-8346

**FUJITSU COMPUTER PRODUCTS OF AMERICA, INC.**

2904 Orchard Parkway, San Jose,  
California 95134-2009, U.S.A.  
TEL: 1-408-432-6333  
FAX: 1-408-894-1709

**FUJITSU CANADA INC.**

2800 Matheson Blvd. East, Mississauga, Toronto,  
Ontario L4W 4X5, CANADA  
TEL: 1-905-602-5454  
FAX: 1-905-602-5457

**FUJITSU EUROPE LIMITED**

Hayes Park Central, Hayes End Road,,  
Hayes, UB4 8FE, U.K.  
TEL: 44-20-8573-4444  
FAX: 44-20-8573-2643

**FUJITSU DEUTSCHLAND GmbH**

Frankfurter Ring 211, 80807 München, GERMANY  
TEL: 49-89-323780  
FAX: 49-89-32378100

**FUJITSU NORDIC AB**

Kung Hans Väg 12, S-192 68 Sollentuna, SWEDEN  
TEL: 46-8-626-4500  
FAX: 46-8-626-4588

**FUJITSU ITALIA S.p.A.**

Via Nazario Sauro, 38 20099 Sesto S. Giovanni (MI), ITALY  
TEL: 39-2-26294-1  
FAX: 39-2-26294-201

**FUJITSU FRANCE S.A.**

1, Place des Etats-Unis, SILIC 310,  
94588 Rungis Cedex, FRANCE  
TEL: 33-1-41-80-38-80  
FAX: 33-1-41-80-38-66

**FUJITSU ICL ESPAÑA S.A.**

Almagro 40, 28010 Madrid, SPAIN  
TEL: 34-91-581-8000  
FAX: 34-91-581-8300

**FUJITSU AUSTRALIA LIMITED**

2 Julius Avenue (Cnr Delhi Road) North Ryde N.S.W. 2113,  
AUSTRALIA  
TEL: 61-2-9776-4555  
FAX: 61-2-9776-4556

**FUJITSU HONG KONG LTD.**

10/F., Lincoln House, 979 King's Road, Taikoo Place, Island East,  
Hong Kong  
TEL: 852-2827-5780  
FAX: 852-2827-4724

**FUJITSU KOREA LTD.**

Coryo Finance Center Bldg, 23-6, YoulDo-Dong,  
Young DungPo-Gu, Seoul, Republic of KOREA  
TEL: 82-2-3787-6000  
FAX: 82-2-3787-6029

**FUJITSU COMPUTERS (SINGAPORE) PTE. LTD**

20 Science Park Road #03-01,  
TELETECH PARK SINGAPORE SCIENCE PARK II,  
Singapore 117674  
TEL: 65-777-6577  
FAX: 65-771-5669

**FUJITSU TAIWAN LTD.**

8F, Hun Tai Center, 168-170, Tun Hwa North Road,  
1st Sec., Taipei, TAIWAN  
TEL: 886-2-545-7700  
FAX: 886-2-717-4644

**FUJITSU SYSTEMS BUSINESS (THAILAND) LTD.**

12th F1., Olympia Thai Tower, 444 Rachadapisek Road,  
Samsennok, Huay Kwang, Bangkok 10320, Thailand  
TEL: 66-2-512-6066  
FAX: 66-2-512-6068

This page is intentionally left blank.

## READER'S COMMENT FORM

Your comments or suggestions on this document are cordially solicited. For any comments and suggestions you may have, please complete and submit this form to your FUJITSU representative. The comments and suggestions will be used in planning future editions. Thank you for your cooperation.

Date issued: \_\_\_\_\_ Manual name: MDG3230UB  
 OPTICAL DISK DRIVES  
 MAINTENANCE MANUAL  
 Name: \_\_\_\_\_  
 Company or organization: \_\_\_\_\_  
 \_\_\_\_\_ Manual code: C156-F047-01EN  
 Address: \_\_\_\_\_  
 \_\_\_\_\_

Comments:

Page	Line	Comments

Reply requested:  Yes  No

Please evaluate overall quality of this manual by marking (√) in the appropriate boxes.

	Good Fair Poor		Good Fair Poor		Good Fair Poor
Organization:	<input type="checkbox"/> <input type="checkbox"/> <input type="checkbox"/>	Use of examples:	<input type="checkbox"/> <input type="checkbox"/> <input type="checkbox"/>	Legibility:	<input type="checkbox"/> <input type="checkbox"/> <input type="checkbox"/>
Accuracy:	<input type="checkbox"/> <input type="checkbox"/> <input type="checkbox"/>	Index coverage:	<input type="checkbox"/> <input type="checkbox"/> <input type="checkbox"/>	Handiness/Binding:	<input type="checkbox"/> <input type="checkbox"/> <input type="checkbox"/>
Clarity:	<input type="checkbox"/> <input type="checkbox"/> <input type="checkbox"/>	Cross referencing:	<input type="checkbox"/> <input type="checkbox"/> <input type="checkbox"/>	_____ (Others):	<input type="checkbox"/> <input type="checkbox"/> <input type="checkbox"/>
Figures & tables:	<input type="checkbox"/> <input type="checkbox"/> <input type="checkbox"/>	General appearance:	<input type="checkbox"/> <input type="checkbox"/> <input type="checkbox"/>		
Technical level:	Too high <input type="checkbox"/>	Appropriate <input type="checkbox"/>	Too low <input type="checkbox"/>		
Overall rating of this publication:	Good <input type="checkbox"/>	Fair <input type="checkbox"/>	Poor <input type="checkbox"/>		

### FOR FUJITSU USE

Overseas office: \_\_\_\_\_ Person in charge: \_\_\_\_\_

Note) Local representative should pass this form to the section in charge of distribution in FUJITSU.

Reply

By \_\_\_\_\_

This page is intentionally left blank





**FUJITSU**