

OPERATOR'S MANUAL DELUXE TWIN CATCHER

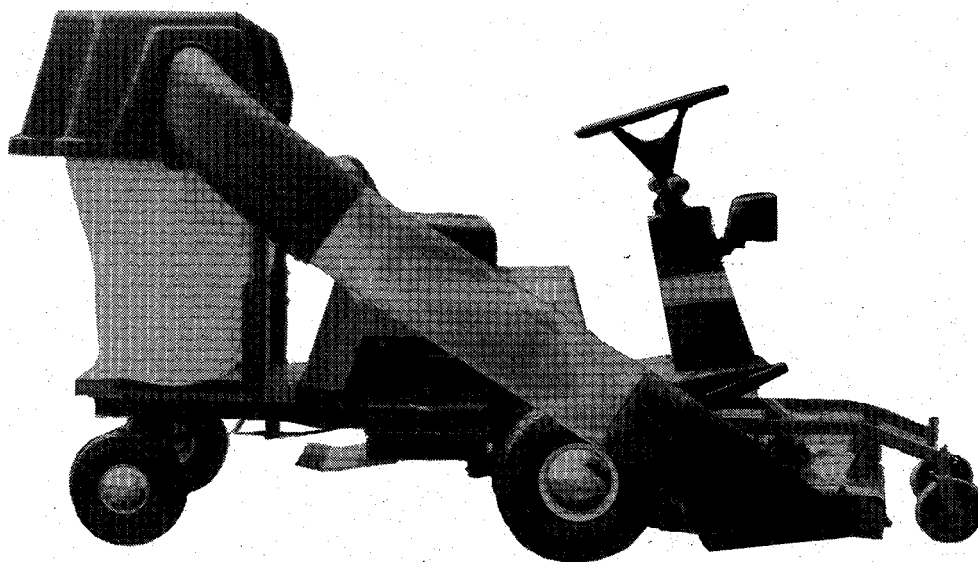

FORM - 1700194
PRINTED IN U.S.A.
8612

DELUXE TWIN CATCHER
FOR FRONT-CUT RIDERS
WITH 36" MOWER
MFG. NO. 1691282

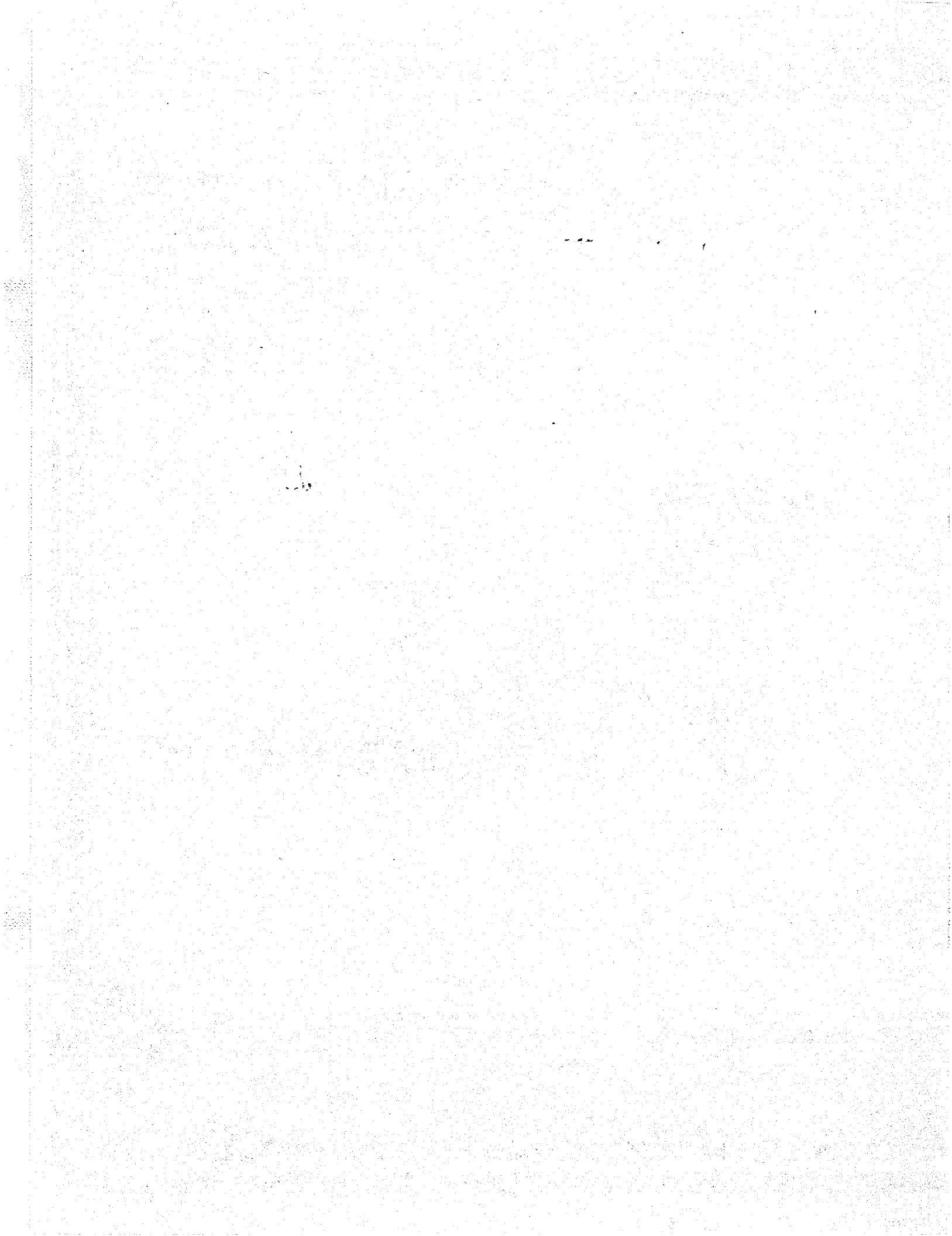

CONTENTS

Assembly	3
Operation and Storage	7
Troubleshooting	Inside Back Cover

Safety Rules



Read these safety rules and the safety rules in your Operator's Manual and follow them closely. Failure to obey these rules could result in loss of control of vehicle, severe personal injury to yourself, or damage to property or equipment. The triangle  in the text signifies important cautions or warnings which must be followed.

ATTENTION SETUP PERSONNEL:

As setup personnel you have the obligations to know the product better than the customer. This includes safety related items. Prior to setup, thoroughly familiarize yourself with the Operator's Manual. Pay special attention to all safety warnings. Remember, it is your responsibility to set up the product safely and to know it well enough to be able to instruct a customer in the safe use of this power unit.

It is possible during setup to place yourself in a position which is more hazardous than when the unit is in operation. Safety is a matter of common sense . . . A matter of thinking before acting. Most shops have specific safety practices. Follow them. The precautions listed in the Operator's Manual should not supersede existing practices but should be considered as supplemental information.



WARNING

Do not operate the tractor unless the entire grass catcher system or mower discharge deflector is properly installed.



WARNING

Do not remove any parts of the grass catcher while the engine is running.



WARNING

Read and obey all safety warnings in your rider Operator's Manual.



WARNING

Under normal use, the bags are subject to wear. Inspect each bag periodically for wear or weak spots, and if necessary, replace with an identical bag.



WARNING

Before raising cover, disengage mower, turn off engine and remove the key. Do not remove catcher tube from adapter or bag while mower is running.



WARNING

Do not stop or start suddenly when operating uphill or downhill. Mow up and down the face of steep slopes; never across the face. Select slow ground speed before driving onto a slope. Never operate on slopes greater than 16° which is a rise of 3 feet (0.91 meters) vertically in 10 feet (3.1 meters) horizontally. Use a rear weight kit on slopes greater than 8° which is a rise of 1.5 feet (0.45 meters) vertically in 10 feet (3.1 meters) horizontally.

Assembly

1. Remove the mower from the rider.
2. Remove the discharge deflector by removing two carriage bolts, lockwashers and nuts. Reinstall the carriage bolts (B, figure 1) using the supplied push nuts (A).
3. Install the baffle (B, figure 2) as shown. Screw the 1/4" whizlock screw (A) into retainer nut in baffle. Insert 1/4" carriage bolt (C) from inside deck and install lockwasher and nut (D).

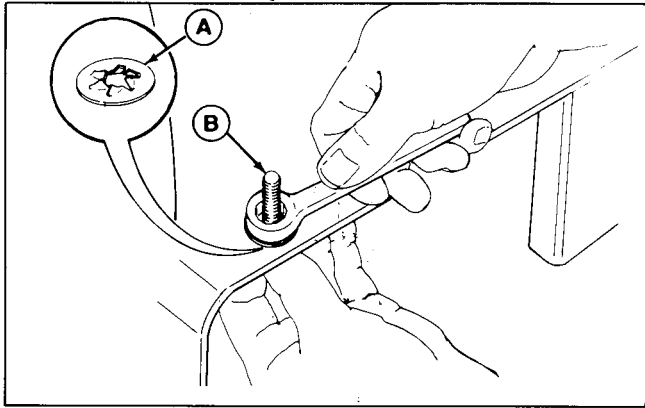

Figure 1.
A. Push Nut
B. Carriage Bolt

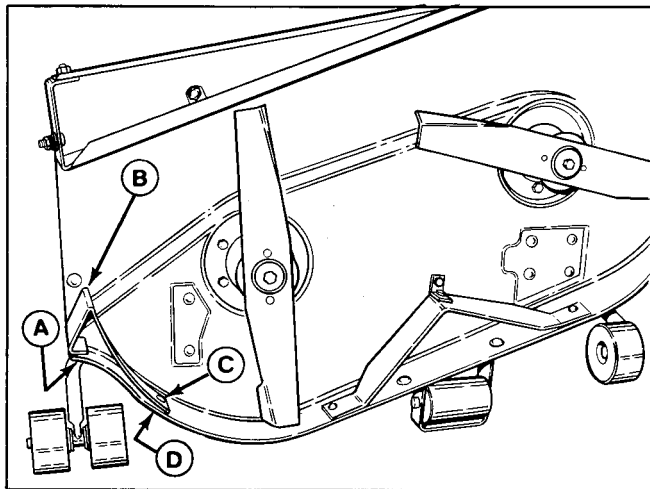

Figure 2.
A. Screw, Whizlock, 1/4-20 x 1/2
B. Baffle
C. Bolt, Carriage, 1/4-20 x 5/8
D. Lockwasher and Nut, 1/4

4. Install the discharge baffle (A, figure 3) as shown. Insert bolt (L) and install push nut (K) fully onto threads to hold bolt (L) in place. (The lockwasher (F), washer (H) and nut (J) will be used to install adapter.

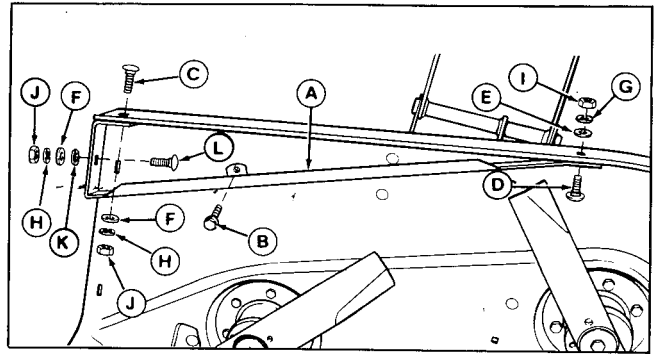

Figure 3.
A. Baffle
B. Screw, Self Tapping, 5/16-18 x 1/2
C. Bolt, Carriage, 3/8-16 x 3/4
D. Bolt, Carriage, 5/16 x 3/4
E. Washer, 1/4
F. Washer, 3/8
G. Lockwasher, 5/16
H. Lockwasher, 3/8
I. Nut, 5/16-18
J. Nut, 3/8-16
K. Push Nut
L. Bolt Carriage, 3/8-16 x 3/4

5. Remove the mower blades and install the new blades with tabs pointing up (toward mower deck). Install the washers and capscrew. Make sure the spline washer engages the shaft splines. Make sure the cup washer is installed concave side up (toward mower deck). Block the blade and torque capscrew to 60 ft. lbs. Note the difference between the two blades (figure 4).

NOTE

Rotate the blades to be sure there is no interference with baffles.



WARNING

Blade mounting capscrews must be installed with the cup washer and spline washer and then securely tightened. Torque blade mounting capscrews to 60 ft. lbs. (81 N.m.).



WARNING

Do not handle the mower blades with bare hands. Avoid touching the cutting edge. Careless or improper handling of blades may result in serious injury.

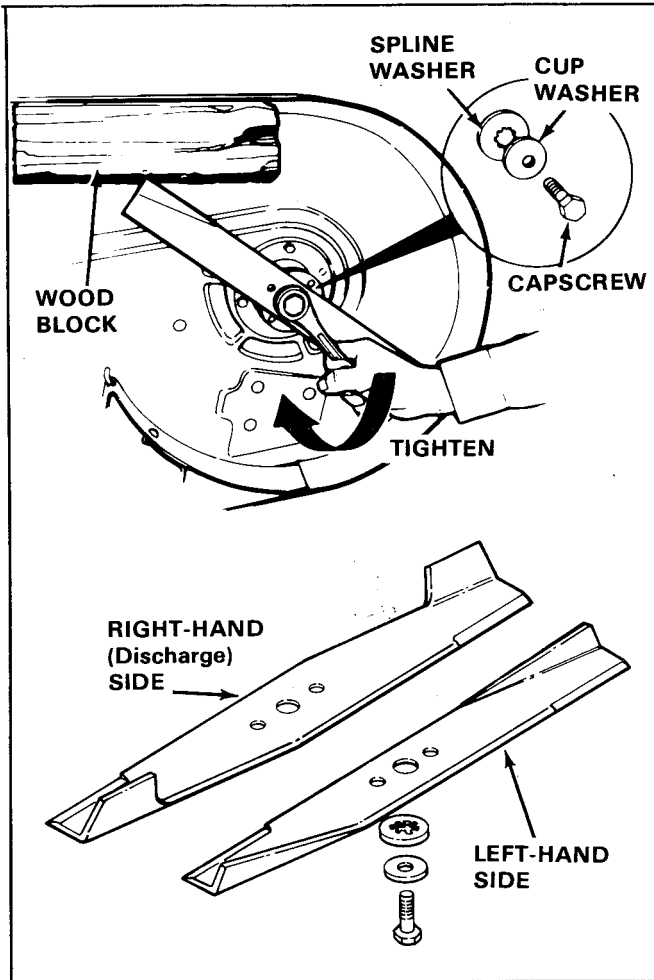

Figure 4.

6. Re-install the mower onto the rider. Place the adapter (A, figure 5) onto the three bolts (B) and install a 3/8" plain washer, lockwasher and nut onto each bolt. (The two lockwashers and nuts on top were used with deflector. The rest of the hardware is supplied with grass catcher.)
7. Use only one weight (G, figure 6) when the grass catcher is installed. Place this weight in the center. Also, be sure rear tire pressure is 18 to 22 psi.

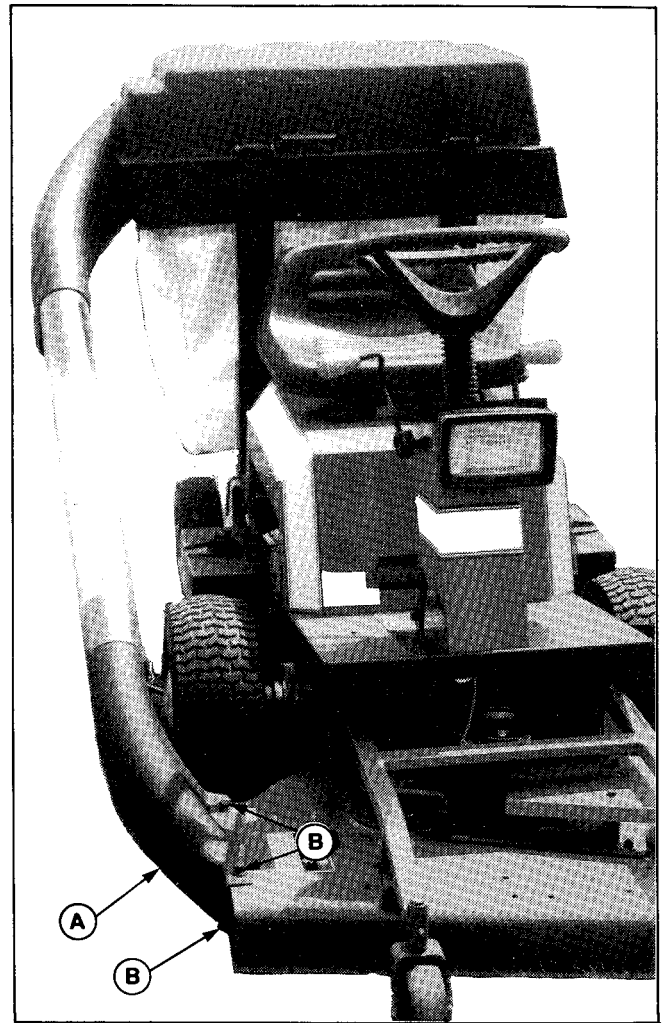

Figure 5. (Grass Catcher Shown Installed)

A. Adapter B. Bolts

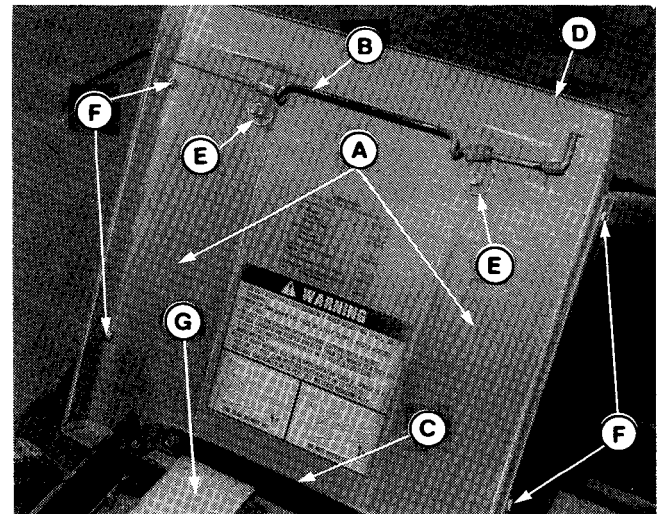

Figure 6.

A. Angle Brackets D. Platform
 B. Latch E. Washer
 C. Hinge F. Capscrews
 G. Weight

8. The hardware for the latch (B, figure 6) and the hinge (C) are used to secure the angle brackets (A) to the bottom of the platform (D). Also the two front bolts (A, figure 7) go through the upper bracket (B). Proceed as follows to install the angle brackets and upper bracket to the platform.

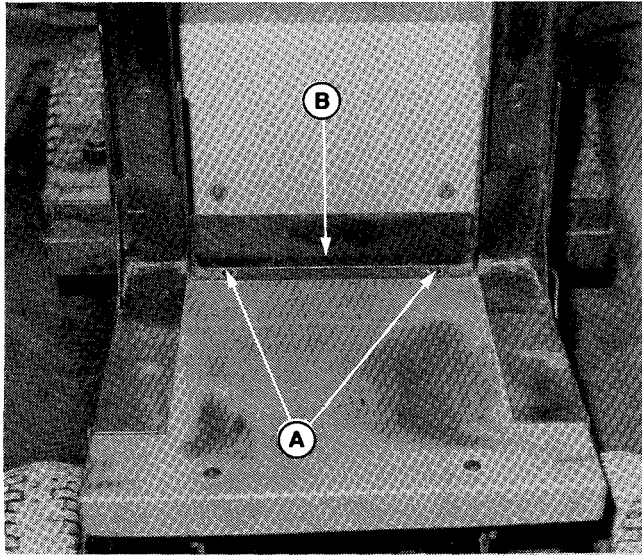

Figure 7

- A. Bolts**
B. Upper Bracket

- a. Remove the platform from the hinge by removing the hardware. Remove the latch (B, figure 6) from the platform.
 - b. Use this existing hardware to attach upper bracket (B, figure 7), angle brackets (A, figure 6), and latch (B) to the platform. Use the same hardware, except add the two supplied 5/16" washers (E, figure 6) (against angle brackets).
 - c. Insert the four supplied 1/4-20 x 3/4" capscrews (F, figure 6) through angle bracket, platform, and upper bracket. Install the 1/4" lockwasher and nuts onto the capscrews.
 - d. Attach the platform (D, figure 6) to the hinge (C) with the original hardware.
9. Attach the two upper braces (A, figure 8) to the bracket (B) with four 5/16-18 x 7/8" capscrews, 5/16" lockwashers and nuts (C).
10. Attach the support plate (A, figure 9) and hinges (B) to the two upper braces (C). Insert four 5/16-18 x 7/8 capscrews from rear, then install 3/8 (ID) x 7/8 (OD) washers, lockwashers and nuts (D) (unless already assembled).

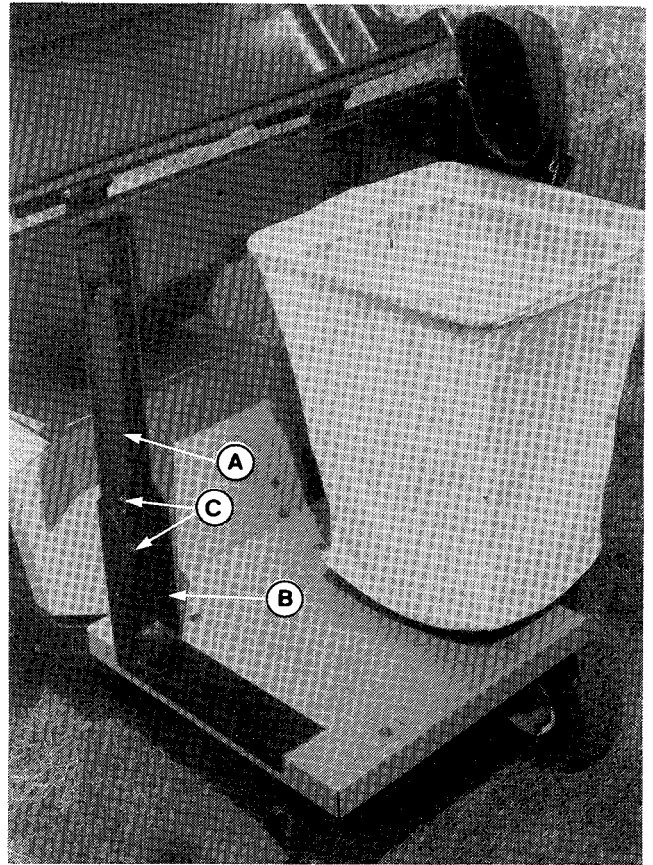

Figure 8.

- A. Upper Brace**
B. Bracket
C. Nuts

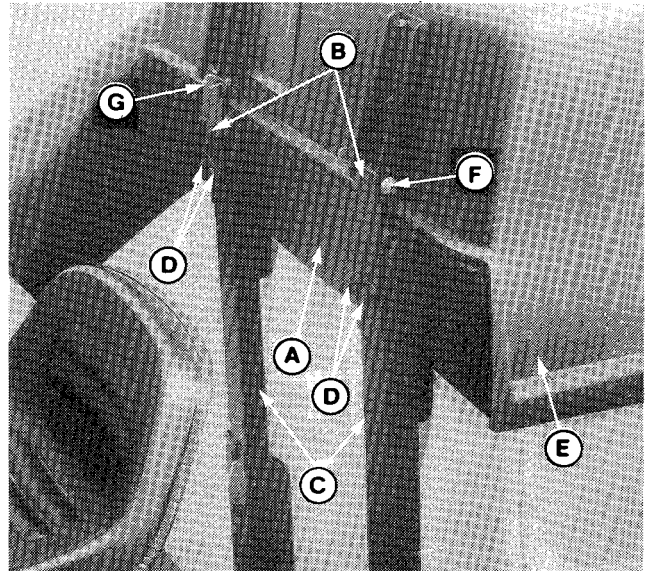

Figure 9 (Shown With Cover Installed)

- A. Support Plate**
B. Hinges
C. Braces
D. Nuts
E. Cover
F. Pin
G. Clip

11. Connect the elbow bracket (B, figure 10) to right-hand rear side of support plate by inserting 5/16-18 x 7/8" carriage bolts (A) from rear and then installing 5/16" lockwashers and nuts.

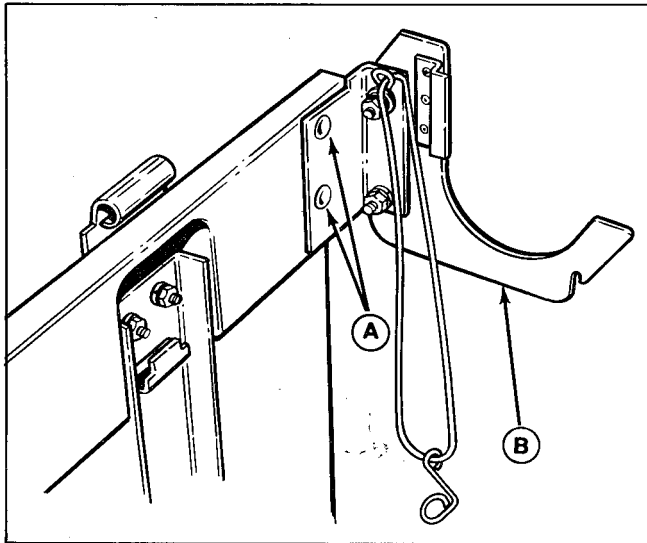

Figure 10.

- A. Bolts
- B. Elbow Bracket

12. Insert tube (A, figure 11) onto adapter (B) so it latches into place.
13. Insert tube (A, figure 12) into elbow, then insert the elbow (B) into the elbow bracket (E). Pull the rubber strap (C) over the elbow and hook as shown.

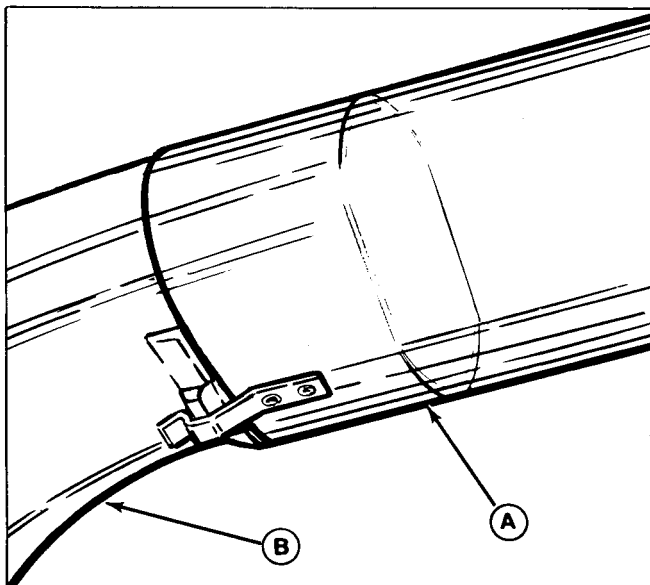

Figure 11.

- A. Tube
- B. Adapter

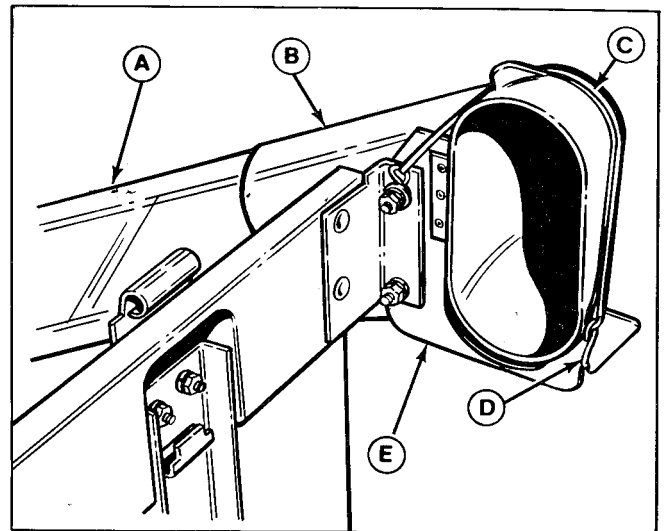

Figure 12.

- A. Tube
- B. Elbow
- C. Rubber Strap
- D. Hook
- E. Elbow Bracket

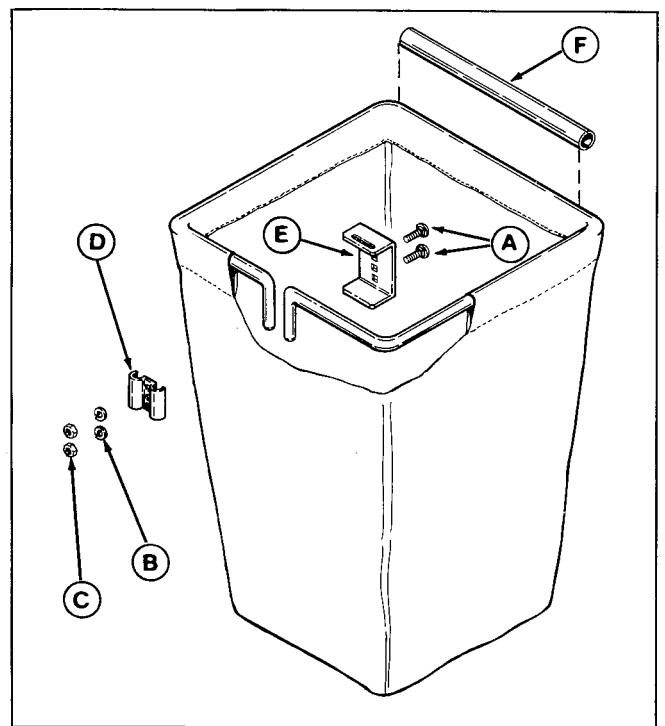

Figure 13.

- A. Bolt, Carriage, 5/16 x 7/8
- B. Lockwasher, 5/16
- C. Nut, 5/16
- D. Bracket
- E. Slotted Bracket
- F. Tube

14. Place cover (E, figure 9) onto the support plate and align the hinges. Insert two pins (F) and install clips (B). The front edge of the cover must seal against the support plate. Loosen nuts (D) to re-position if necessary, then tighten.
15. Connect the brackets (D & E, figure 13) to the bag frames with slot toward top. Use two carriage bolts (A), lockwashers and nuts for each bag. Use top and bottom holes in brackets (D & E); the middle hole will be empty. The clotch is shown cut away for clarity only - be sure the brackets are outside of the bag.
16. Install the tubes (F, figure 13) onto the bags as shown.
17. Hang the bags onto the frame (figure 14) by hooking onto slotted bracket.

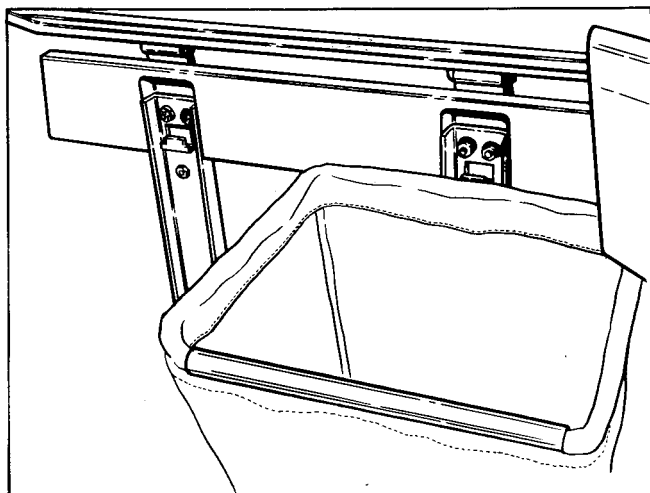

Figure 14.

Operation and Storage

BEFORE OPERATION

Clear the lawn of all sticks, stones, wire and other debris which may be caught or thrown by the mower blades.

Clean the mid-tube with warm water and mild detergent (other products may damage tube). Use a soft sponge or cloth. The flow of grass can be seen through the tube while mowing.

Check grass condition. If wet, wait until later in the day. If grass is wet, plugging may occur.

For efficient bagging, air circulation under the mower deck, through the chute and into the bag is very important. For this reason, you should remove grass and debris from underside of mower deck, discharge chute and screen inside cover.

The adapter, tube and elbow can be removed as an assembly for cleaning. Remove the nuts and washers that hold the adapter to mower deck and unhook rubber strap from elbow.

If desired, the bags can be lined with 30 gallon trash bags for easy disposal.

OPERATION

Grass should be cut often, and not too short. If grass is too long or lush it may be necessary to keep ground speed to a minimum or to cut only half the width to prevent clogging. If grass is high, operate with mower in high cutting position. Cut the grass again in lower cutting position, if desired.

To check if bags are full, open the inspection door, located directly behind the operator's seat.

Always operate with throttle at full speed.

EMPTYING THE BAGS

Raise the cover. If a plastic liner was not used, unhook the bag and turn upside down to empty (use handle on bottom).

If plastic liner was used, first tie up top of liner. Then, either pull the liner out, or turn the bag upside down and allow the filled liner to slide out.



WARNING

For safety reasons grass and debris are to be removed only after engine is shut off, key removed, and all moving parts stopped.



WARNING

Before raising cover, shut off engine, remove key, and set parking brake.

STORAGE

1. Clean the grass catcher thoroughly.
2. If paint has been scratched on metal parts, coat with paint or oil.
3. Store in a dry area. Hang the bags to dry. Always store away from moisture.

REMOVAL

1. Remove the three nuts (B, figure 5) lockwashers and plain washers that secure the adapter. The lockwashers and nuts will be used in step 3 to install mower deflector.
2. Raise the cover and disconnect the rubber strap (C, figure 12). Remove the adapter, tube and elbow as an assembly.
3. Install the deflector (A, figure 15) with two 3/8-16 x 3/4" carriage bolts, lockwashers and nuts.
4. Use two rear weights (G, figure 6) to operate without catcher. Place one on each side.



WARNING

Never operate mower without grass catcher unless discharge deflector is installed.

5. For best performance when mowing without catcher, use standard blades (see Assembly Section to install blades). To remove the brackets or any other parts, refer to Assembly Section.

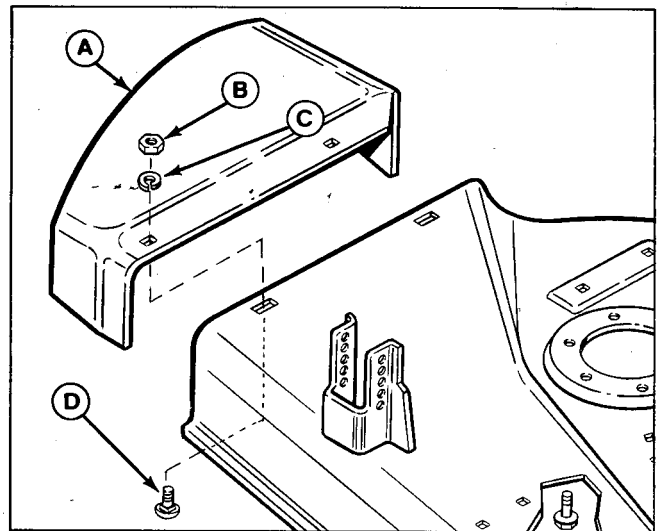



Figure 15.

- A. Deflector
- B. Nut, 3/8-16
- C. Lockwasher, 3/8
- D. Bolt, Carriage, 3/8-16 x 3/4

Troubleshooting

This section provides troubleshooting instructions for the more common and easily corrected problems. See Table 1. For problems not covered, see your dealer.

 **WARNING**

To avoid serious injury, perform maintenance on the grass catcher only after stopping the engine and waiting for all moving parts to come to a complete stop. Always remove the ignition key before beginning the maintenance to prevent accidental starting of the engine. Disconnect the spark plug wire and fasten away from plug.

Table 1. Troubleshooting

Problem	Cause/Remedy
<p>1. Leaves and grass not being completely picked up.</p>	<ul style="list-style-type: none"> A. Engine speed too slow. Run at full throttle. B. Ground speed too fast. Use slower speed. C. Mower drive belt slipping. Check belt tension per rider Operator's Manual. C. Discharge tube plugged. Stop engine and remove key. Then remove and unplug discharge tube. E. Using wrong mower blades. See Assembly Instructions. F. Blades not tight. Torque to 60 ft. lbs. G. Mower not level. See Operator's Manual to level Mower.
<p>2. Grass catcher discharge tube or mower plugs easily.</p>	<ul style="list-style-type: none"> A. Bags full. Empty bags. B. Grass too high. Reduce tractor ground speed, reduce cutting width or raise mower adjustment for the first pass, lower it for the second pass. C. Grass or leaves too wet. Wait for drier conditions. D. Build-up of cut grass in mower or adapter. Clean thoroughly. E. Screen in grass bag cover clogged. Remove cover and clean screens. F. Using wrong mower blades. See Assembly Instructions.

