

CRIMESTOPPER

SECURITY PRODUCTS, INC.

REMOTE CONTROL ENTRY SYSTEM

INSTALLATION INSTRUCTIONS

CS-830RKE

INTRODUCTION

There are two types of features of the system.

Primary: These features **MUST BE CONNECTED** for proper system operation.

Optional: These features connected only if wanted. All optional features are marked "OPTIONAL"

As the installation progresses you may connect any "Optional" features of the system. Optional features are listed with primary features only when they effect the operation of the primary feature.

We hope this brief introduction helps eliminate confusion when installing your system. Should you experience trouble during installation, tech support is available by calling:



1 (800) 998-6880

Monday - Friday 8:00am - 4:30pm Pacific Time

This device complies with FCC Rules part 15. Operation is subject to the following two conditions: (1) this device may not cause harmful interference, and (2) this device must accept any interference that may be received, including interference that may cause undesired operation. The manufacturer is not responsible for any radio or TV interference caused by unauthorized modifications to this equipment. Such modification could void the user's authority to use the equipment

CONTROL MODULE MOUNTING

The Control module should be mounted in a concealed location. Placement will effect the distance from which the transmitter can control the unit. Because the RF receiving antenna extends from the module, the wire antenna should be routed at least 1/2 inch away from the nearest metal. DO NOT alter the length of antenna wire or route it with any other wiring.

!!! DO NOT GROUND THE ANTENNA WIRE !!!

MOUNTING LOCATIONS

DO NOT MOUNT THE CONTROL MODULE IN ENGINE COMPARTMENT

UNDERDASH MOUNTING If locating the control module underdash, the unit should be placed as high as possible so as not to interfere with the driver's feet. DRIVER'S SIDE underdash mounting provides easy location for wiring. ALSO, the left side of the dash has more metal and wiring which could cause decreased remote control range. **ALWAYS PLACE UNIT AS HIGH AS IS POSSIBLE FOR BEST CONCEALMENT AND OPERATING RANGE.**

PASSENGER SIDE underdash mounting is often the best location for operating range and concealment. Removing the glove box often reveals excellent mounting locations for the control board. Extra wiring may be required to route wiring across the dash area.

UNDERSEAT MOUNTING: This location may be used, however it may not be an advantage for the following reasons:

- 1) The seat is made of steel framework and springs, this blocks RF and the low mounting location also limits RF receiving.
- 2) The control unit can be exposed to excessive moisture from water and spilled drinks. This moisture stays in the carpet padding causing corrosion to the circuit board which is not cover by our warranty.

MOUNTING COMPONENTS

LED MOUNTING (optional)(LED not included)

LED should be located in a visible location on the dashboard or console. Many vehicles now have small knockout panels which provide excellent locations for LED's.

DRILL A 15/64" HOLE IN CHOSEN LOCATION, route LED wires through hole and press LED firmly in place.

EMERGENCY OVERRIDE SWITCH MOUNTING

This switch is multi-purpose, used for emergency override, and programming. Mount the switch in a hidden location. The user **MUST** be able to access this switch in an emergency.

DRILL A 15/64" HOLE IN CHOSEN LOCATION

Make certain there is enough room on the back side so that the switch wires will not accidentally short out on any metal. Use the supplied nuts and washers to secure the switch in place.

WIRING

MAIN HARNESS: 10 PIN: 18 GA. WIRES

RED WIRE: +12 VOLT POWER

Connect to Constant +12 Volt power source with supplied In-Line 10 Amp fuse and Fuse Holder.

BLACK WIRE: CHASSIS GROUND

Connect to body metal of the vehicle using a sheet metal screw.

YELLOW WIRE: IGNITION SWITCHED "ON" and "START" +12 VOLTS

Connect to an Ignition wire (or fuse in the fuse box) that shows +12 Volts when the key is in Both the "On" and "Start" positions.

ORANGE WIRE: (-)NEG. STARTER DISABLE OUTPUT (optional)

This wire is connected to Terminal 85 of a Relay for the Starter Disable. Connect Terminal 86 to the YELLOW Ignition switched wire. Cut the vehicle starter wire. Connect one half to Terminal 30, the other half to Terminal 87A.
(Requires a SPDT RELAY Part No. CS-402A)

WHITE WIRE: +12V FLASHING PARKING LIGHT OUTPUT (optional)

Connect to any Parking Light or to the Parking light output at the back of the Headlight switch.
!! DO NOT CONNECT TO DASH DIMMER CIRCUIT !!

VIOLET WIRE: (-)PASSENGER DOOR UNLOCK OUTPUT (optional)

Connect to Terminal #85 of a relay to activate power door locking system. This wire activates only with a Double press of the lock/unlock button when unlocking the vehicle with the remote control. If the factory system use a negative trigger relay system, the wire may be connected directly to the factory unlock switch wire, otherwise USE A RELAY! See *Diagrams Page 4*.

GRAY WIRE: (-)REMOTE OUTPUT #1(optional) (requires relay)

Connect to terminal 85 of relay. Connect terminal 86 to +12 Volt constant. Connect terminal 87 to +12V Constant or Ground. Connect terminal 30 to device to be activated.

PINK WIRES(2): PROGRAMMABLE OUTPUT

DOME LIGHT ILLUMINATION or REMOTE OUTPUT #2 (optional)

These two wires are the Term. #87 & #30 of an ON-Board Relay. This relay may be used for activating the interior light of a vehicle, or as a 2nd remote controlled output.

FOR DOME LIGHT ILLUMINATION: Connect one wire to the vehicle's door pin switch wire and the other to either ground or power, depending on the door switch polarity.

Neg. door switch: connect to ground

Pos. door switch: connect to power

FOR REMOTE OUTPUT 2: Connect one wire to either power or ground, and the other wire to the device to be activated.

LED and OVERRIDE SWITCH PLUGS: 2 PIN: 22 GA.

Connect LED(not included) and EMERGENCY OVERRIDE SWITCH to the appropriate header on the board. Plugs and sockets are color-coded to match one another.

POWER DOOR LOCK WIRING

DOOR LOCK PLUG: 3 PIN: 22 GA.

BLUE WIRE: (-)NEG. UNLOCK/(+)POS. LOCK OUTPUT
Connect to factory unlock relay, or to relay to activate motors.

GREEN WIRE: (-)NEG. LOCK/(+)POS. UNLOCK OUTPUT
Connect to factory lock relay, or to relay to activate motors.

RED WIRE: + 12V CONSTANT
Connect to terminal #85(or#86) of relay for activating reverse polarity, and aftermarket door locking systems.

POWER DOOR LOCK WIRING DIAGRAMS

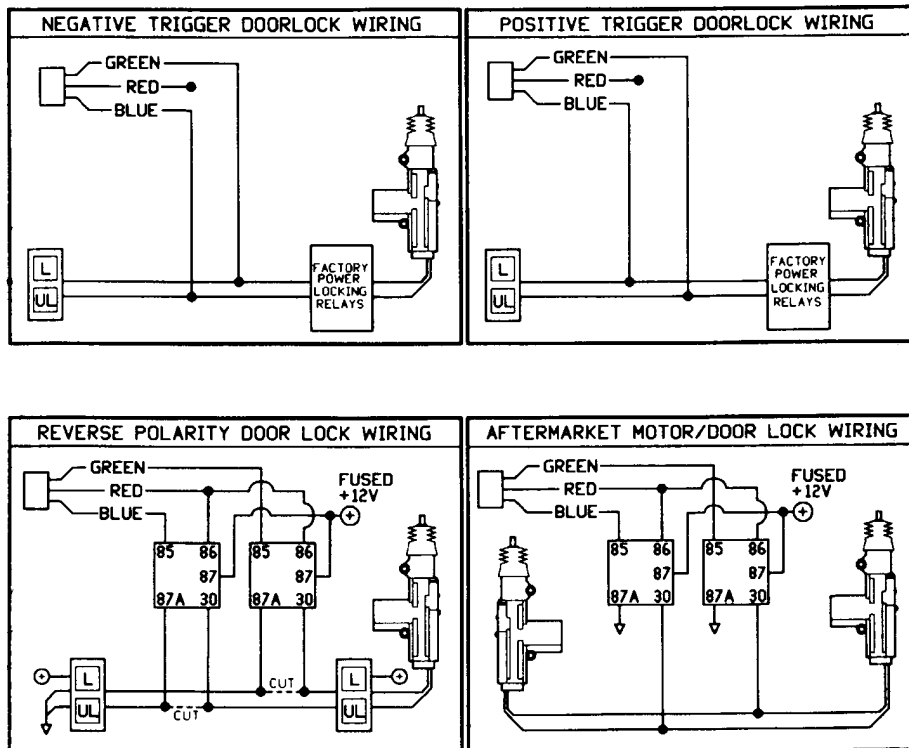

SEPARATE DRIVER/PASSENGER UNLOCK WIRING

WIRING FOR REVERSE POLARITY DOOR LOCKS

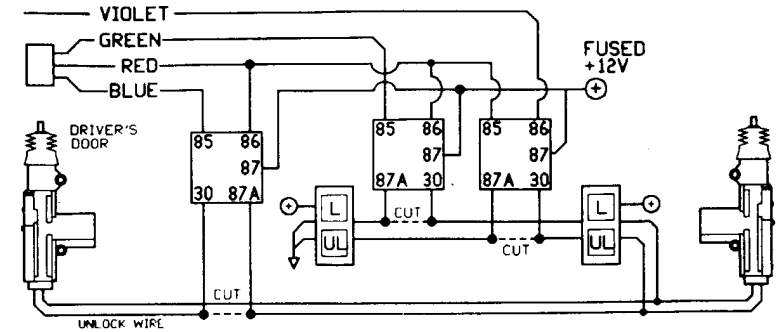

WIRING FOR POSITIVE TRIGGER DOOR LOCKS

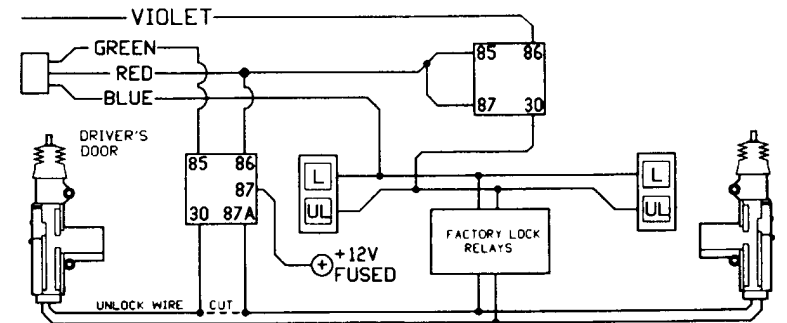

WIRING FOR NEGATIVE TRIGGER DOOR LOCKS

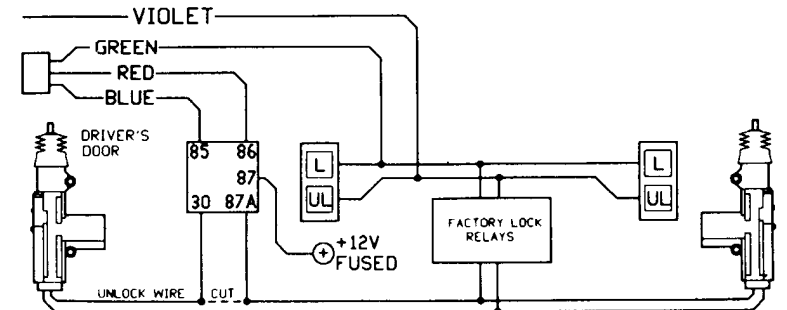

PROGRAMMING

DIP SWITCH PROGRAMMING

There are 4 Dip switches under the access door of the control module for point of installation programming. ONLY SWITCHES 1,2 & 3 OPERATE, 4 HAS NO EFFECT.

DIP SWITCH #1: DOOR LOCK/UNLOCK PULSE TIME

ON: PULSE TIME = .75 SECOND
OFF: PULSE TIME = 3 SECONDS

DIP SWITCH #2: IGNITION CONTROLLED LOCK/UNLOCK

ON: LOCK/UNLOCK WITH IGNITION
OFF: NO LOCK/UNLOCK WITH IGNITION

DIP SWITCH #3: PROGRAMMABLE OUTPUT

ON: DOME LIGHT ILLUMINATION w/UNLOCK
OFF: REMOTE OUTPUT #2

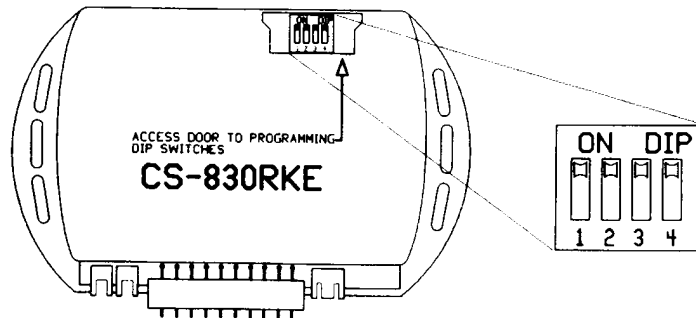

PROGRAMMING

TRANSMITTER PROGRAMMING

This system uses Code Learning to learn up to 3(three) different transmitter codes.

TO PROGRAM TRANSMITTERS TO Control Module:

- 1) Turn Ignition switch ON 3 times quickly (on/off, on/off, on) until Lights flash once.
Leave Ignition ON.
- 2) Push and HOLD the Override switch. The Lights flash 3 times.
The system is now in programming mode.
- 3) Press BUTTON #1 on transmitter - Lights flash once to confirm programming. Press Button #1 on another transmitter within 5 seconds to program a second remote control.

NOTE 1: If only one transmitter is being programmed, continue holding Button #1 for about 5 seconds. Holding the transmitter button prevents unauthorized code and noise from entering the system.

NOTE 2: Program Mode is exited automatically after 5 seconds of last code transmission or once three new codes have been programmed. System will LOCK after programming, Unlock using any valid transmitter.

- 4) TURN IGNITION OFF.

