

35772G

Gas hob

Operating Instructions

GB

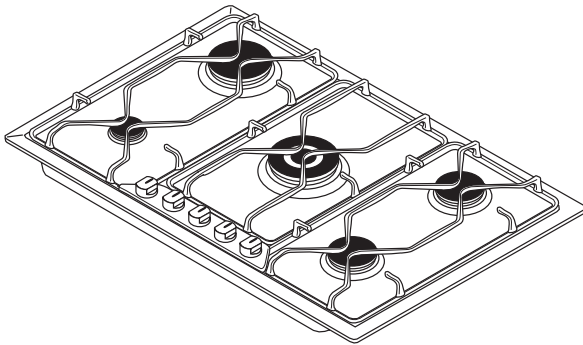

PERFEKT IN FORM UND FUNKTION



Important Safety Information

You MUST read these warnings carefully before installing or using the hob. If you need assistance, contact our Customer Care Department on 08705 350350

Installation

- This hob must be installed by qualified personnel, according to the manufacturer's instructions and to the relevant British Standards.
- Any gas installation must be carried out by a registered CORGI installer.
- Remove all packaging before using the hob.
- Ensure that the gas and electrical supply complies with the type stated on the rating plate, located near the gas supply pipe.
- Do not attempt to modify the hob in any way.

Child Safety

- This hob is designed to be operated by adults. Do not allow children to play near or with the hob.
- The hob gets hot when it is in use. Children should be kept away until it has cooled.
- Children can also injure themselves by pulling pans or pots off the hob.

During Use

- This hob is intended for domestic cooking only. It is not designed for commercial or industrial purposes.
- This appliance is not connected to a combustion products evacuation device. It must be installed and connected in accordance with current installation regulations. Particular attention shall be given to the relevant requirements regarding ventilation.
- When in use a gas cooking hob will produce heat and moisture in the room in which it has been installed. Ensure there is a continuous air supply, keeping air vents in good condition or installing a cooker hood with a venting hose.
- When using the hob for a long period of time, the ventilation should be improved, by opening a window or increasing the extractor speed.
- Do not use this hob if it is in contact with water. Do not operate the hob with wet hands.

- Ensure the control knobs are in the 'OFF' position when not in use.
- When using other electrical appliances, ensure the cable does not come into contact with the hot surfaces of the cooking appliance.
- Unstable or misshapen pans should not be used on the hob as unstable pans can cause an accident by tipping or spillage.
- Never leave the hob unattended when cooking with oil and fats.
- Never use plastic or aluminium foil dishes on the hob.
- Perishable food, plastic items and aerosols may be affected by heat and should not be stored above or below the hob unit.

Service

- This hob should only be repaired or serviced by an authorised Service Engineer and only genuine approved spare parts should be used.



Environmental Information

- After installation, please dispose of the packaging with due regard to safety and the environment.
- When disposing of an old appliance, make it unusable, by cutting off the cable.
- The symbol  on the product or on its packaging indicates that this product may not be treated as household waste. Instead it shall be handed over to the applicable collection point for the recycling of electrical and electronic equipment. By ensuring this product is disposed of correctly, you will help prevent potential negative consequences for the environment and human health, which could otherwise be caused by inappropriate waste handling of this product. For more detailed information about recycling of this product, please contact your local city office, your household waste disposal service or the shop where you purchased the product.

Keep this instruction book for future reference and ensure it is passed on to any new owner.

These instructions are only valid for countries whose identification symbols are shown on the cover of this instruction booklet and on the appliance itself.

Contents

Instructions for the User

Important Safety Information	2
Description of the Hob	5
Operation	6
Maintenance and Cleaning	7
Something Not Working?	8
Service and Spare Parts	9
Customer Care	9
Guarantee Conditions	10

Instructions for the Installer

Engineers technical data	11
Important safety requirements	12
Installation	13
Electrical connections	17
Wiring diagram	18
Fault Finding	19
Commissioning	22
Conversion from Natural Gas to LPG	23

Guide to Use the instructions

The following symbols will be found in the text to guide you throughout the Instructions:



Safety Instructions



Step by step instructions for an operation



Hints and Tips



Environmental information



This appliance complies with the following E.E.C. Directives:

-73/23 - 90/683 (Low Voltage Directive);

-89/336 (Electromagnetical Compatibility Directive);

-93/68 (General Directives)

and subsequent modifications.

Description of the Hob

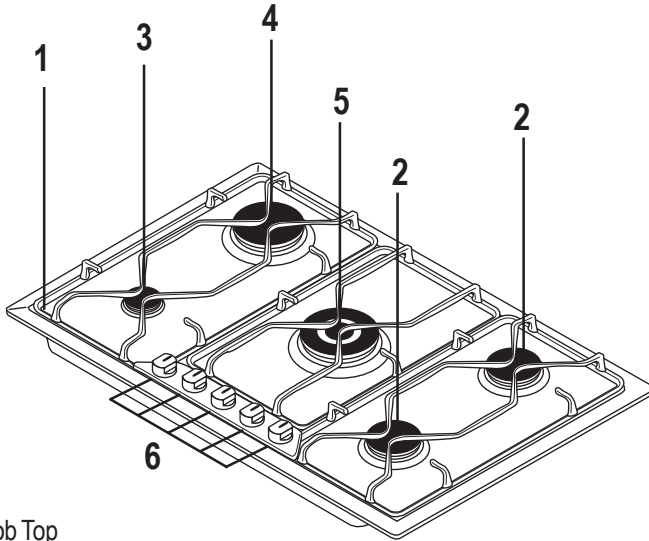

Fig. 1

1. Hob Top
2. Semi-rapid burner
3. Auxiliary burner
4. Rapid burner
5. Ultra-rapid burner (triple crown)
6. Control knobs

Installation



Any gas installation must be carried out by a registered CORGI installer, and in accordance with existing rules and regulations.

The relevant instructions are to be found in the second section of this manual.

Please, ensure that, once the hob is installed, it is easily accessible for the engineer in the event of a breakdown.

WHEN THE HOB IS FIRST INSTALLED

Once the hob has been installed, it is important to remove any protective materials, which were put on in the factory.

Operation

Hob burners control knobs

The symbols on the knobs mean that :

- there is no gas supply
- ☆▲ there is maximum gas supply
- ▲ there is minimum gas supply

Lighting the burners

i For easier lighting, proceed before putting a pan on the pan support.

 To light a burner, turn the relevant knob anticlockwise to maximum position (☆▲), then push it down to ignite the burner. Upon ignition, adjust the flame as required. If the burner does not ignite, turn the control knob to zero, and try again.

i When switching on the mains, after installation or a power cut, it is quite normal for the spark generator to be activated automatically.

i In the absence of electricity, ignition can occur without the electrical device; in this case, approach the burner with a flame, push the relevant knob down and turn it anti-clockwise until it reaches the "maximum" position.

Burner	minimum diameter	maximum diameter
Triple-crown (ultra-rapid)	160 mm	260 mm
Large (rapid)	160 mm	240 mm
Medium (semi-rapid)	120 mm	220 mm
Small (auxiliary)	80 mm	160 mm

i As soon as a liquid starts boiling, turn down the flame so that it will barely keep the liquid simmering.



If you use a saucepan which is smaller than the recommended size, the flame will spread beyond the bottom of the vessel, causing the handle to overheat.

Take care when frying food in hot oil or fat, as the overheated splashes could easily ignite.

If the control knobs become difficult to turn, please contact your local Service Force Centre.

Using the Wok Stand

A wok stand is provided to enable you to use a round bottomed wok on the hob. The wok stand must only be used on the central burner, and should not be used with any other type of wok or pan. When fitting the wok stand, ensure the recesses in the frame fit securely onto the bars of the pan supports, as shown in figure 3.

Fig. 2

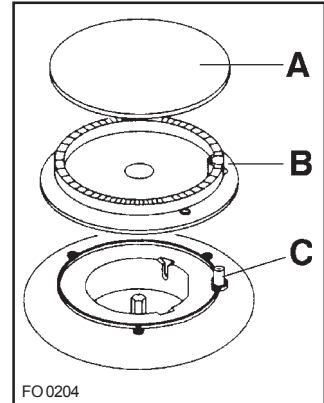

A - Burner cap

B - Burner crown

C - Ignition electrode

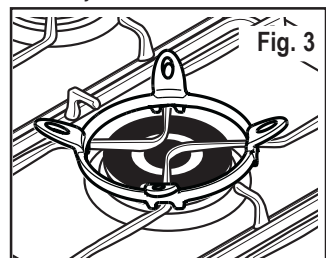

Maintenance and Cleaning



Before any maintenance or cleaning can be carried out, you must **DISCONNECT** the hob from the electricity supply.

The hob is best cleaned whilst it is still warm, as spillage can be removed more easily than if it is left to cool.

The Hob Top

Regularly wipe over the hob top using a soft cloth well wrung out in warm water to which a little washing up liquid has been added. Avoid the use of the following:

- household detergent and bleaches;
- impregnated pads unsuitable for non-stick saucepans;
- steel wool pads;
- bath/sink stain removers.

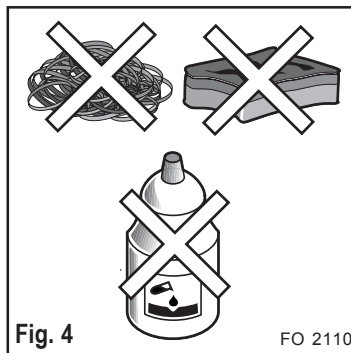

Should the hob top become heavily soiled, the following products are recommended:

- For stainless steel hobs use a proprietary stainless steel cleaner.
- For other hobs use Hob Brite or Bar Keepers Friend.

Pan Supports

When washing the pan supports by hand, take care when drying them as the enamelling process occasionally leaves rough edges. If necessary, remove stubborn stains using a paste cleaner.

The Burners

The burner caps and crowns can be removed for cleaning.

Wash the burner caps and crowns using hot soapy water, and remove marks with a mild paste cleaner. A well moistened soap impregnated steel wool pad can be used with caution, if the marks are particularly difficult to remove.

After cleaning, be sure to wipe dry with a soft cloth.

Ignition electrode

The electric ignition is obtained through a ceramic electrode and a metal electrode (Fig. 2 - lett. C). Keep these components very clean, to avoid difficult lighting, and check that the burner crown holes (Fig. 2 - lett. B) are not obstructed.

Something Not Working?

If the hob is not working correctly, please carry out the following checks before contacting your local Service Force Centre.

SYMPTOM	SOLUTION
<ul style="list-style-type: none">■ There is no spark when lighting the gas	<ul style="list-style-type: none">◆ Check that the unit is plugged in and the electrical supply is switched on◆ Check that the RCCB has not tripped (if fitted)◆ Check the mains fuse has not blown◆ Check the burner cap and crown have been replaced correctly, e.g. after cleaning.
<ul style="list-style-type: none">■ The gas ring burns unevenly	<ul style="list-style-type: none">◆ Check the main jet is not blocked and the burner crown is clear of food particles.◆ Check the burner cap and crown have been replaced correctly, e.g. after cleaning.

If after all these checks, your hob still does not operate correctly, contact your local Service Force Centre.

Please note that it will be necessary to provide proof of purchase for any in-guarantee service calls.

In-guarantee customers should ensure that the above checks have been made as the engineer will make a charge if the fault is not a mechanical or electrical breakdown.

Service and Spare Parts

If you require spare parts or an engineer contact your local Service Force Centre by telephoning:

0870 5 929 929

Your call will be routed to your local Service Force Centre.

For the address of your local Service Force Centre and further information about Service Force, please visit the website at **www.serviceforce.co.uk**

When you contact the Service Centre, they will need the following information:

1. Your name, address and post code.
2. Your telephone number
3. Clear and concise details of the fault
4. The model and the serial number (see rating label on the back of this instruction booklet)
5. Date of purchase

Customer Care

For general enquiries concerning your AEG-Electrolux appliance and for further information on AEG-Electrolux products, contact our Customer Care Department by letter or telephone at the address below or visit our website at **www.aeg.co.uk**

Customer Care Department

AEG-Electrolux Domestic Appliances

55 - 77 High Street

Slough

Berkshire

SL1 1DZ

Tel : 08705 350350*

* calls to this number may be recorded for training purposes.

Guarantee Conditions

Standard guarantee conditions

We, AEG-Electrolux, undertake that if within 12 months of the date of the purchase this AEG-Electrolux appliance or any part thereof is proved to be defective by reason only of faulty workmanship or materials, we will, at our discretion repair or replace the same **FREE OF CHARGE** for labour, materials or carriage on condition that:

- The appliance has been correctly installed and used only on the electricity or gas supply stated on the rating plate.
- The appliance has been used for normal domestic purposes only, and in accordance with the manufacturer's operating and maintenance instructions.
- The appliance has not been serviced, maintained, repaired, taken apart or tampered with by any person not authorised by us.
- All service work under this guarantee must be undertaken by a Service Force Centre. Any appliance or defective part replaced shall become the Company's property.
- This guarantee is in addition to your statutory and other legal rights.
- Home visits are made between **8.30am and 5.30pm** Monday to Friday. Visits may be available outside these hours in which case a **premium** will be charged.

Exclusions

This guarantee does not cover:

- Damage or calls resulting from transportation, improper use or neglect, the replacement of any light bulbs or removable parts of glass or plastic.
- Costs incurred for calls to put right an appliance which is improperly installed or calls to appliances outside the United Kingdom.
- Appliances found to be in use within a commercial environment, plus those which are subject to rental agreements.
- Products of AEG-Electrolux manufacture which are not marketed by AEG-Electrolux.

European Guarantee

If you should move to another country within Europe then your guarantee moves with you to your new home subject to the following qualifications:

- The guarantee starts from the date you first purchased your product.
- The guarantee is for the same period and to the same extent for labour and parts as exists in the new country of use for this brand or range of products.
- This guarantee relates to you and cannot be transferred to another user.
- Your new home is within the European Community (EC) or European Free Trade Area.
- The product is installed and used in accordance with our instructions and is only used domestically, i.e. a normal household.
- The product is installed taking into account regulations in your new country.

Before you move, please contact your nearest Customer Care centre, listed below, to give them details of your new home. They will then ensure that the local Service Organisation is aware of your move and able to look after you and your appliances.

France	Senlis	+33 (0)3 44 62 29 29
Germany	Nürnberg	+49 (0)800 234 7378
Italy	Pordenone	+39 (0)800 117511
Sweden	Stockholm	+46 (0)8 672 53 60
UK	Slough	+44 (0)1753 219899

Instruction for the Installer

Engineers technical data

Overall dimensions

Width:	680 mm
Depth:	510 mm

Cut out dimensions

Width:	560 mm
Depth:	480 mm

Supply Connections

Gas: R 1/2 inch (1/2 inch male) Rear right hand corner

Electric: 230 V 50 Hz supply, 3 core flexible cable with non rewirable plug fitted with a 3 amp cartridge fuse.

Heat Input

Ultra-rapid Burner	4.0 kW (13652 BTU/HR)
Rapid Burner	2.8 kW Natural Gas (10239 BTU/HR) 2.8 kW L.P.G. (9556 BTU/HR)

Burner	Dia. Tap By-pass 1/100 mm
Auxiliary	28
Semi-rapid	32
Rapid	40
Ultra-rapid	56
Aeration adjustment none	

Semi-rapid Burner 2.0 kW (6824 BTU/HR)

Auxiliary Burner 1.0 kW (3413 BTU/HR)

Appliance class 3

Appliance category II2H3+

Gas supply Natural gas G 20 / 20 mbar

TYPE OF GAS	BURNER POSITION	RAPID (large)		SEMI-RAPID (medium)		AUXILIARY (small)		TRIPLE CROWN	
		MAX	MIN	MAX	MIN	MAX	MIN	MAX	MIN
NATURAL GAS 20 mbar VALUE = 37.78 MJ/m ³ Ws - 50.7 MJ/ m ³	NOMINAL THERMAL POWER (kW)	2.8	0.65	2.0	0.45	1.0	0.33	4.0	1.2
	NOMINAL FLOW RATE (m ³ /h)	0.266	0.062	0.190	0.043	0.095	0.028	0.381	0.114
	NOZZLE REFERENCE (1/100 mm)	113	Adjust.	96	Adjust.	70	Adjust.	146	Adjust.
LPG GAS 28-30/37 mbar VALUE = 49.92 MJ/Kg	NOMINAL THERMAL POWER (kW)	2.8	0.65	2.0	0.45	1.0	0.33	4.0	1.2
	NOMINAL FLOW RATE (g/h)	202	47	144	32	72	24	288	86
	NOZZLE REFERENCE (1/100 mm)	86	40	71	32	50	28	98	56

Important safety requirements

This hob must be installed in accordance with the Gas Safety (Installation and Use) Regulations (Current Edition) and the IEE Wiring Regulations (Current Edition). Detailed recommendations are contained in the following British Standards Codes Of Practice: B.S. 6172/ B.S. 5440, Part 2 and B.S. 6891 Current Editions.

The hob should not be installed in a bed sitting room with a volume of less than 20 m³. If it is installed in a room of volume less than 5 m³ an air vent of effective area of 110 cm² is required. If it is installed in a room of volume between 5 m³ and 10 m³ an air vent of effective area of 50 cm² is required, while if the volume exceeds 11 m³ no air vent is required. However, if the room has a door which opens directly to the outside no air vent is required even if the volume is between 5 m³ and 11 m³. If there are other fuel burning appliances in the same room, B.S. 5440 Part 2 Current Edition, should be consulted to determine the requisite air vent requirements.

Location

The hob may be located in a kitchen, a kitchen/diner or bed sitting room, but not in a bathroom or shower room.

Before making the cut out in the worktop ensure that the edges of the hob that are to be near either a side or rear wall have a minimum distance of 55 mm between the edge of the hob and the wall.

The minimum distance combustible material can be fitted above the hob is 400 mm. If it is fitted below 400 mm, a space of 50 mm must be allowed from the edges of the hob. The minimum distance combustible material can be fitted directly above the hob is 700 mm. A minimum distance of 100 mm must be left between the side edges of the hob and any adjacent cabinets or walls.

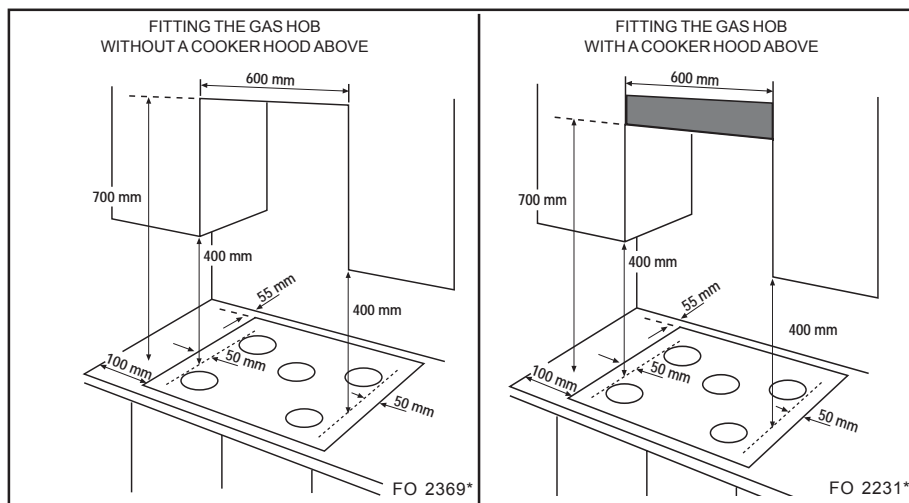

Installation

Important



This hob must be installed by **qualified personnel** to the relevant British Standards.

Any gas installation must be carried out by a CORGI registered installer.

The manufacturer will not accept liability, should the above instructions or any of the other safety instructions incorporated in this book be ignored.

On the end of the shaft, which includes the G 1/2" threaded elbow, adjustment is fixed so that the washer is fitted between the components as shown in the diagram. Screw the parts together without using excessive force.

Gas Connection

Connection to the gas supply should be with either rigid or semi-rigid pipe, i.e. steel or copper.

The connection should be suitable for connecting to R 1/2" (1/2 BSP male thread).

When the final connection has been made, it is essential that a thorough leak test is carried out on the hob and installation.

Ensure that the main connection pipe does not exert any strain on the hob.

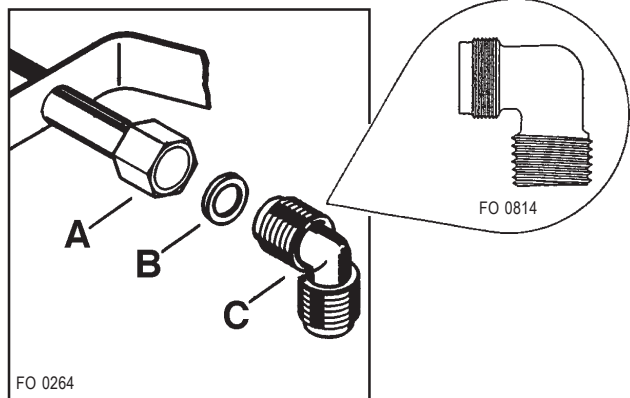

It is important to install the elbow correctly, with the shoulder on the end of the thread, fitted to the hob connecting pipe.

Failure to ensure the correct assembly will cause leakage of gas.

Cut Out Size

The dimensions of the cut-out are given in the diagram.

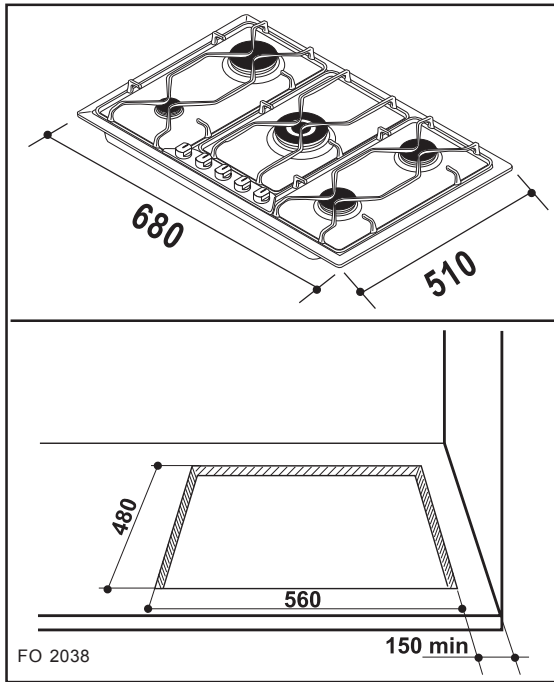

Building In

Building over a cupboard or drawer

If the hob is to be installed above a cupboard or drawer it will be necessary to fit a heat resistant board below the base of the hob on the underside of the work surface.

It is also recommended to carry out the electrical connection to the hob as shown in diagrams 1 and 2 (see next page).

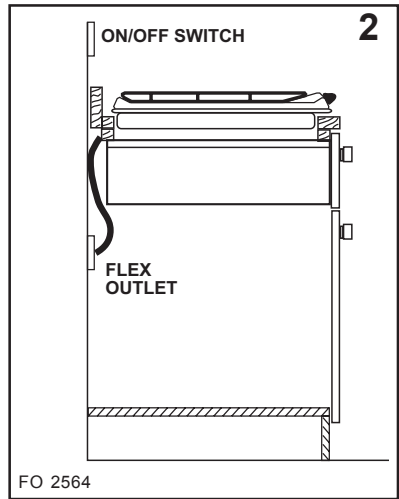
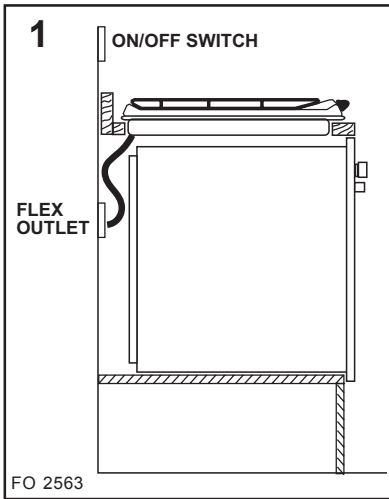

Building over a kitchen unit with door

Proper arrangements must be taken in designing the furniture unit, in order to avoid any contact with the bottom of the hob which can be heated when it is operated. The recommended solution is shown in diagram 3.

The panel fitted under the hob ("a") should be easily removable to allow easy access if technical assistance is needed. The space behind the kitchen unit ("b") can be used for connections.

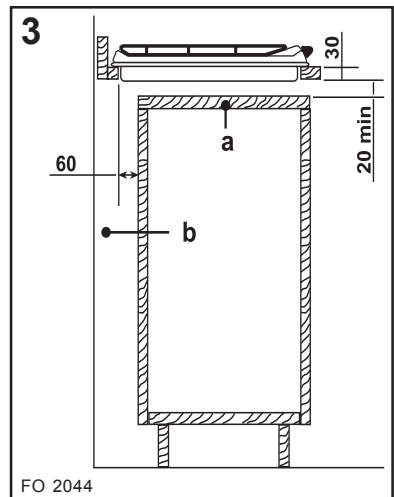

Dimensions are given in mm.

Fitting the Hob into the worktop

 Carry out the building in of the hob as follows:

- put the seals supplied with the hob, on the edges of the cut out: place them exactly on the front and rear edge and at 50 mm. from the side edges, as shown in the diagram, taking care that the seals meet without overlapping;
- place the hob in the cut out, taking care that it is centred;
- fix the hob with the relevant fixing clamps and screws, as shown in the diagram.

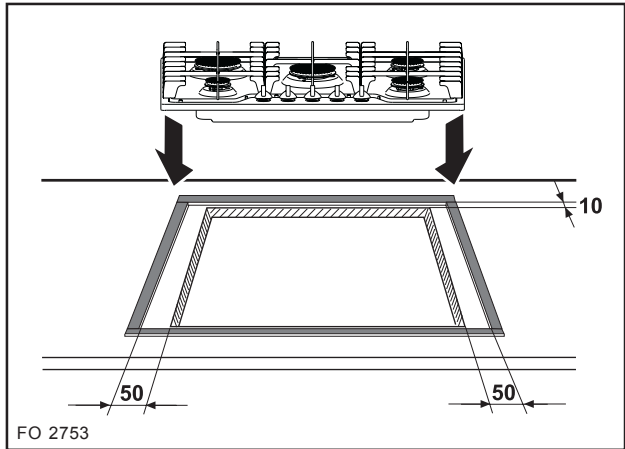

When the screws have been tightened, the excess seal can be removed.

The edge of the hob forms a double seal which prevents the ingress of liquids.

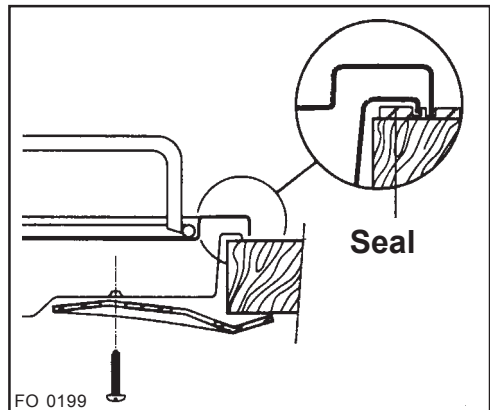

Electrical connections



Any electrical work required to install this hob should be carried out by a qualified electrician or competent person, in accordance with the current regulations.

THIS HOB MUST BE EARTHED.

The manufacturer declines any liability should these safety measures not be observed.

This hob is designed to be connected to a 230-240V 50Hz AC electrical supply.

Before switching on, make sure the electricity supply voltage is the same as that indicated on the hob rating plate. The rating plate is located on the bottom of the hob. A copy is attached on the back cover of this book.

The hob is supplied with a 3 core flexible supply cord incorporating a 13 amp plug fitted. In the event of having to change the fuse, a 3amp ASTA approved (BS 1362) fuse must be used.

Should the plug need to be replaced for any reason, the wires in the mains lead are coloured in accordance with the following code:

Green and Yellow - Earth

Blue - Neutral

Brown - Live

- 1) Connect the green and yellow (earth) wire to the terminal in the plug which is marked with the letter 'E' or the earth symbol  or coloured green and yellow.
- 2) Connect the blue (neutral) wire to the terminal in the plug which is marked with the letter 'N' or coloured black.
- 3) Connect the brown (live) wire to the terminal in the plug which is marked with the letter 'L' or coloured red.

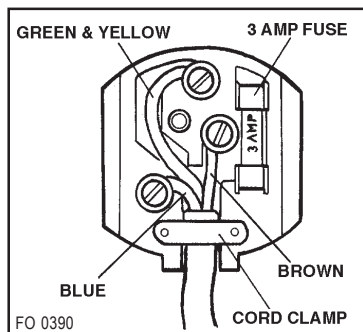

Upon completion there must be no cut, or stray strands of wire present and the cord clamp must be secure over the outer sheath.

In the event of having to change the fuse, a 3amp ASTA approved (BS 1362) fuse must be used.



A cut off plug inserted into a 13 amp socket is a serious safety (shock) hazard. Ensure that the cut off plug is disposed of safely.

Permanent Connection

In the case of a permanent connection, it is necessary that you install a double pole switch between the hob and the electricity supply (mains), with a minimum gap of 3 mm. between the switch contacts and of a type suitable for the required load in compliance with the current electric regulations.

The switch must not break the yellow and green earth cable at any point.



Ensure that the hob supply cord does not come into contact with surfaces with temperatures higher than 50 deg. C.

Replacement of the cable

The connection of the voltage cable to the appliance's terminal block is of type "Y". This means that its replacement requires the specific equipment of a technician.

In this case, only cable types H05 V2V2-F (T90) must be used. The cable section must be suitable to the voltage and the working temperature.

The yellow/green earth wire must be approximately 2 cm. longer than the phase wires.

Wiring diagram

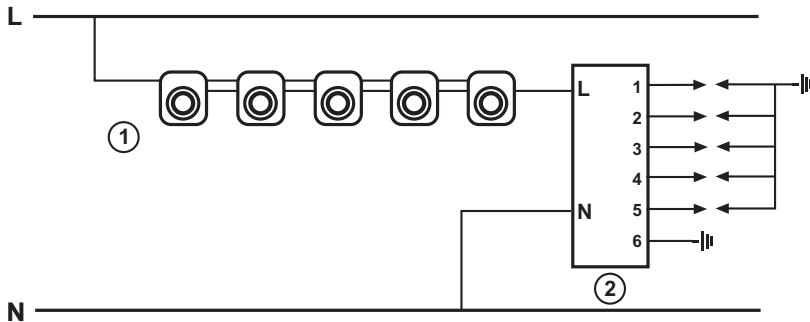

1. IGNITOR SWITCHES

2. IGNITOR UNIT

Fault Finding

Preliminary Electrical Systems Check

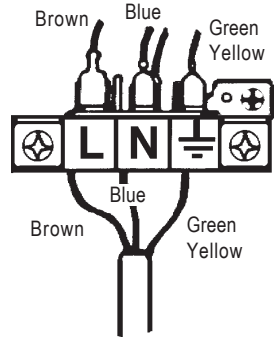

START

Isolate appliance and carry out:
A: Earth Continuity check.

NO **YES**

Carry out:
C: Polarity check.

Carry out:
D: Resistance to Earth check.

Has inlet fuse blown?

NO

YES

Electricity supply should now be satisfactory.

Inlet wiring faulty.
Rectify any fault.

PLUG (with cover removed)

Earth Wire
Green/Yellow

Neutral Wire
Blue

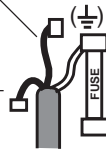

SOCKET (face view)

E (Earth symbol)

N

L

Isolate appliance and carry out:
B: Insulation check.
Rectify any fault including replacing fuses as necessary.

A. EARTH CONTINUITY CHECK

Appliance must be electrically disconnected - meter set on Ω (Ohms) x 1 scale and adjust zero if necessary.

- Test leads from any appliance earth point to earth pin on plug. Resistance should be less than 0.1 Ω (Ohm), check all earth wires for continuity and all contacts are clean and tight.

B. INSULATION CHECK

Appliance electrically disconnected, all switches ON.

- a) meter set on Ω (Ohms) x 1 scale.

Test leads from L to N in appliance terminal block. If meter reads «0» then there is a short circuit.

- b) meter set on Ω (Ohm) x 100 scale.

Repeat test with leads from L to E. If meter reads less than ∞ (infinity) there is a fault.

NOTE - Should it be found that the fuse has failed but no fault is indicated - a detailed continuity check (i.e. by disconnecting and checking each component) is required to trace the faulty component.

It is possible that a fault could occur as a result of local burning/arcing but no fault could be found under test. However a detailed visual inspection should reveal evidence of burning around the fault.

Ignition System / Gas Ignition

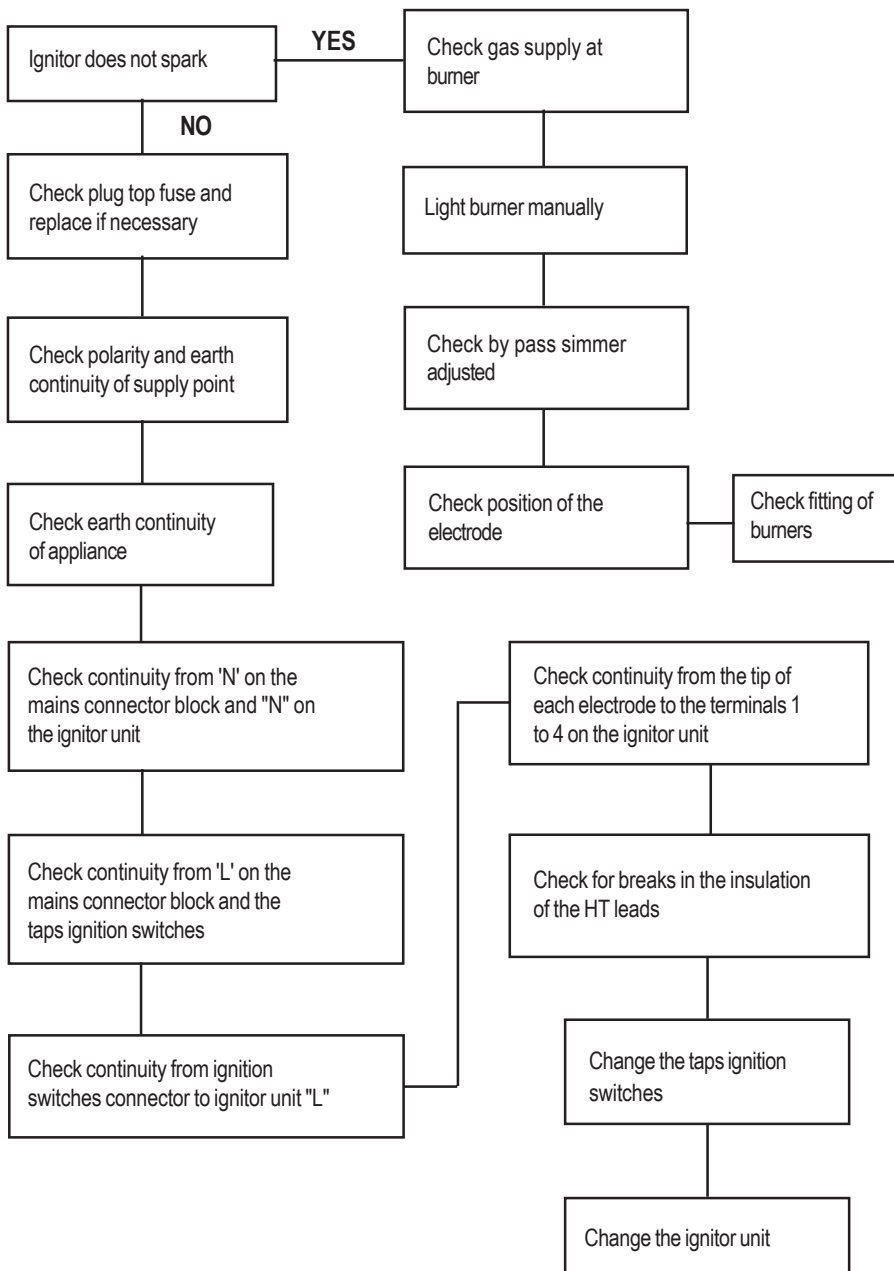

Commissioning

When the hob has been fully installed it will be necessary to check the minimum flame setting. To do this, follow the procedure below.

- Turn the gas tap to the MAX position and ignite.
- Set the gas tap to the MIN flame position then turn the control knob from MIN to MAX several times. If the flame is unstable or is extinguished follow the procedure below.

Procedure:



Re-ignite the burner and set to MIN.

Remove the control knob.

To adjust, use a thin bladed screwdriver and turn the adjustment screw (see diagram) until the flame is steady and does not extinguish, when the knob is turned from MIN to MAX. Repeat this procedure for all burners.

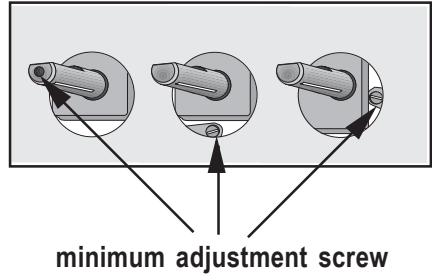

Pressure Testing



Remove left hand pan support and front left burner cap and crown.

Fit manometer tube over the injector.

Turn on the burner gas supply and ignite another burner.

The pressure reading should be nominally 20mbar and must be between 17 mbar and 25mbar.

Turn off the burner supplies.

Conversion from Natural Gas to LPG



IMPORTANT

The replacement/conversion of the gas hob should only be undertaken by a competent person.

It is important to note that this model is designed for use with natural gas but can be converted for use with butane or propane gas providing the correct injectors are fitted. The gas rate is adjusted to suit.

Method

- Ensure that the gas taps are in the 'OFF' position
- Isolate the hob from the electrical supply
- Remove all pan supports, burner caps, rings, crowns and control knobs.
- With the aid of a 7mm box spanner the burner injectors can then be unscrewed and replaced by the appropriate LPG injectors.

To adjust the gas rate

With the aid of a thin bladed screwdriver completely tighten down the by pass adjustment screw. Upon completion stick the replacement rating plate on the under side of the hob.

AEG Haugeräte GmbH
Postfach 1036
D-90327 Nürnberg

<http://www.aeg.hausgeraete.de>

© Copyright by AEG

 **From the Electrolux Group. The world's No.1 choice.**

The Electrolux Group is the world's largest producer of powered appliances for kitchen, cleaning and outdoor use. More than 55 million Electrolux Group products (such as refrigerators, cookers, washing machines, vacuum cleaners, chain saws and lawn mowers) are sold each year to a value of approx. USD 14 billion in more than 150 countries around the world.