

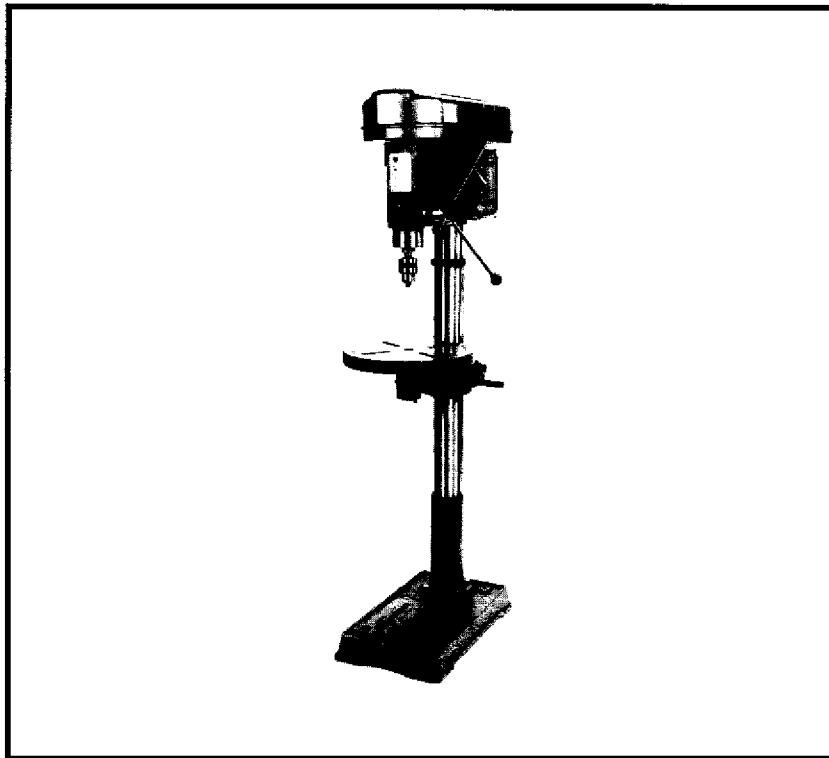

**DRILL PRESS  
MODEL G1201  
INSTRUCTION MANUAL**



**GRIZZLY IMPORTS, INC.**

COPYRIGHT ©1993 BY GRIZZLY IMPORTS, INC.  
WARNING: NO PORTION OF THIS MANUAL MAY BE REPRODUCED IN ANY  
SHAPE OR FORM WITHOUT THE WRITTEN APPROVAL OF GRIZZLY IMPORTS, INC.  
PRINTED IN USA, MAY 1993

# WARNING

Some dust created by power sanding, sawing, grinding, drilling, and other construction activities contains chemicals known to the State of California to cause cancer, birth defects or other reproductive harm. Some examples of these chemicals are:

- Lead from lead-based paints.
- Crystalline silica from bricks, cement, and other masonry products.
- Arsenic and chromium from chemically treated lumber.

Your risk from these exposures varies, depending on how often you do this type of work. To reduce your exposure to these chemicals: work in a well ventilated area, and work with approved safety equipment, such as those dust masks that are specially designed to filter out microscopic particles.

# WOODWORKING EQUIPMENT SAFETY INSTRUCTIONS

## **WARNING**

### **For Your Own Safety Read Instruction Manual Before Operating This Equipment**

Woodworking can be fun and rewarding, however it can also be a dangerous activity if safe and proper operating procedures are not followed. Please take the time to review the manual which was supplied with your machine, as well as these general safety instructions. Make sure you have properly assembled and adjusted the machine before operating it the first time. Also make certain you understand the procedures you are going to perform. Thinking through the steps or going through the motions of the operation with the machine off is often a good way to anticipate potential problems. Always use common sense and exercise caution in the workshop. If a procedure feels dangerous or awkward, don't do it!

If the instruction manual does not answer your questions, or you cannot find assistance from other woodworking books or references, please contact Grizzly Industrial's Customer Service:

**Grizzly Industrial, Inc.**  
1203 Lycoming Mall Circle  
Muncy, PA 17756  
Phone: (570) 546-9663  
Fax: 1-800-438-5901  
E-Mail: [techsupport@grizzly.com](mailto:techsupport@grizzly.com)  
Web Site: <http://www.grizzly.com>

## **WARNING**

### **Safety Instructions For Power Tools**

- 1. KEEP GUARDS IN PLACE** and in working order.
- 2. REMOVE ADJUSTING KEYS AND WRENCHES.** Form a habit of checking to see that keys and adjusting wrenches are removed from tool before turning on.
- 3. KEEP WORK AREA CLEAN.** Cluttered areas and benches invite accidents.
- 4. DO NOT USE IN DANGEROUS ENVIRONMENT.** DO NOT use power tools in damp or wet locations, or where any flammable or noxious fumes may exist. Keep work area well lighted.
- 5. KEEP CHILDREN AND VISITORS AWAY.** All children and visitors should be kept a safe distance from work area.
- 6. MAKE WORK SHOP CHILD PROOF** with padlocks, master switches, or by removing starter keys.
- 7. DO NOT FORCE TOOL.** It will do the job better and safer at the rate for which it was designed.
- 8. USE RIGHT TOOL.** DO NOT force tool or attachment to do a job for which it was not designed.

# WARNING

## Safety Instructions For Power Tools

9. **USE PROPER EXTENSION CORD.** Make sure your extension cord is in good condition. Conductor size should be in accordance with the chart below. The amperage rating should be listed on the motor or tool nameplate. An undersized cord will cause a drop in line voltage resulting in loss of power and overheating. Your extension cord must also contain a ground wire and plug pin. Always repair or replace extension cords if they become damaged.

Minimum Gauge for Extension Cords

AMP RATING	LENGTH		
	25ft	50ft	100ft
0-6	16	16	16
7-10	16	16	14
11-12	16	16	14
13-16	14	12	12
17-20	12	12	10
21-30	10	10	No

10. **WEAR PROPER APPAREL.** DO NOT wear loose clothing, gloves, neckties, rings, bracelets, or other jewelry which may get caught in moving parts. Non-slip footwear is recommended. Wear protective hair covering to contain long hair.
11. **ALWAYS USE SAFETY GLASSES.** Also use face or dust mask if cutting operation is dusty. Everyday eyeglasses only have impact resistant lenses, they are NOT safety glasses.
12. **SECURE WORK.** Use clamps or a vise to hold work when practical. It's safer than using your hand and frees both hands to operate tool.
13. **DO NOT OVERREACH.** Keep proper footing and balance at all times.
14. **MAINTAIN TOOLS WITH CARE.** Keep tools sharp and clean for best and safest performance. Follow instructions for lubricating and changing accessories.
15. **USE RECOMMENDED ACCESSORIES.** Consult the owner's manual for recommended accessories. The use of improper accessories may cause risk of injury.
16. **REDUCE THE RISK OF UNINTENTIONAL STARTING.** On machines with magnetic contact starting switches there is a risk of starting if the machine is bumped or jarred. Always disconnect from power source before adjusting or servicing. Make sure switch is in OFF position before reconnecting.
17. **MANY WOODWORKING TOOLS CAN "KICKBACK" THE WORKPIECE** toward the operator if not handled properly. Know what conditions can create "kickback" and know how to avoid them. Read the manual accompanying the machine thoroughly.
18. **CHECK DAMAGED PARTS.** Before further use of the tool, a guard or other part that is damaged should be carefully checked to determine that it will operate properly and perform its intended function. Check for alignment of moving parts, binding of moving parts, breakage of parts, mounting, and any other conditions that may affect its operation. A guard or other part that is damaged should be properly repaired or replaced.
19. **NEVER LEAVE TOOL RUNNING UNATTENDED. TURN POWER OFF.** DO NOT leave tool until it comes to a complete stop.
20. **NEVER OPERATE A MACHINE WHEN TIRED, OR UNDER THE INFLUENCE OF DRUGS OR ALCOHOL.** Full mental alertness is required at all times when running a machine.

### CAUTION

No list of safety guidelines can be complete. Every shop environment is different. Always consider safety first, as it applies to your individual working conditions. Use this and other machinery with caution and respect. Failure to do so could result in serious personal injury, damage to equipment or poor work results.

# WARRANTY CARD

NAME \_\_\_\_\_ PHONE NUMBER \_\_\_\_\_

STREET \_\_\_\_\_

CITY \_\_\_\_\_ STATE \_\_\_\_\_ ZIP \_\_\_\_\_

MODEL # \_\_\_\_\_ PURCHASED FROM GRIZZLY, BELLINGHAM, WA   
OR WILLIAMSPORT, PA

INVOICE # \_\_\_\_\_

**The following information is given on a voluntary basis. This information will be used for marketing purposes to help Grizzly develop better products. Your name will be included in our mailing list only. It will not be sold to other companies. Of course, all information is strictly confidential.**

1. How did you find out about us?

Advertisement     Friend     Other \_\_\_\_\_  
 Catalog     Card deck

2. Do you think your machine represents good value?                      YES \_\_\_                      NO \_\_\_

3. Would you allow us to use your name as a reference for Grizzly customers in your area?                      YES \_\_\_                      NO \_\_\_  
(Note: Your name will be used a maximum of three times.)

4. To which of the following publications do you subscribe? Check all that apply.

Fine Woodworking     Popular Woodworking     FDM     Practical Homeowner  
 American Woodworker     Fine Homebuilding     Wood & Wood Products     Home Handyman  
 Woodwork     Workbench     Old House Journal     Shop Notes  
 WOOD     Woodsmith     Journal of Light Construction     Cabinetmaker  
 Woodworker's Journal     Woodshop News     Wooden Boat     Other \_\_\_\_\_

5. What is your annual household income?

\$20,000-\$30,000                       \$60,001-\$70,000  
 \$30,001-\$40,000                       \$70,001-\$80,000  
 \$40,001-\$50,000                       \$80,001-\$90,000  
 \$50,001-\$60,000                       + \$90,000

6. To which age group do you belong?

20-30     41-50     61-70  
 31-40     51-60     +70

7. Which of the following stationary woodworking machines do you own? Check all that apply.

Table Saw                       Jointer                       Lathe                       Scroll Saw  
 Band Saw                       Planer                       Panel Saw                       Mortiser  
 Radial Arm Saw                       Drill Press                       Air Compressor & tools                       Other  
 Wide Belt Sander                       Shaper                       Dust Collector  
 Drum Sander                       Power Feeder                       Vacuum Veneer Press

8. How many of the machines you checked in Question 7 are Grizzly machines? \_\_\_\_\_

9. Which of the following portable woodworking machines or power tools do you own? Check all that apply.

Circular Saw                       Saber Saw                       Miter Saw                       Biscuit Joiner                      Other: \_\_\_\_\_  
 Drill/Driver                       Recipro Saw                       Belt Sander                       Orbital Sander  
 R-O Sander                       Router                       Planer                       Detail Sander

10. Which of these machines or other tools would you like Grizzly to carry? Check all that apply.

Radial Arm Saw                       Biscuit Joiner                       Combination Planer/Jointer                      Other: \_\_\_\_\_  
 Panel Saw                       Pin Router                       12" Table Saw  
 Vertical Spindle Sander                       Mortiser                       24" Planer

11. Of all the mail order woodworking companies you have purchased from, how do you rate Grizzly in terms of overall customer satisfaction?

The best                       Above average                       Average  
 Below average                       The worst

12. Comments: \_\_\_\_\_

FOLD ALONG THIS LINE

---

From:

---

---

---

PLACE  
STAMP  
HERE



GRIZZLY IMPORTS

P O BOX 2069

BELLINGHAM WA 98227-2069

---

FOLD ALONG THIS LINE

TAPE ALONG EDGES—PLEASE DO NOT STAPLE

# TABLE OF CONTENTS

I. INTRODUCTION.....	1
II. SAFETY RULES FOR ALL TOOLS .....	2
III. UNPACKING .....	4
IV. PIECE INVENTORY .....	4
V. CLEAN UP BEFORE ASSEMBLY .....	5
VI. ELECTRICAL SERVICE REQUIREMENTS .....	6
A. CIRCUIT LOADING .....	6
B. GROUNDING .....	6
C. GENERAL INFORMATION .....	6
D. LIGHT .....	6
E. WORD OF CAUTION .....	6
VII. ASSEMBLY .....	7
A. CHUCK INSTALLATION .....	10
B. CHUCK REMOVAL .....	11
VIII. GETTING READY TO USE YOUR DRILL PRESS .....	11
IX. OPERATIONS .....	12
A. GENERAL PROCEDURES .....	13
B. METAL.....	13
C. WOOD .....	13
D. REFERENCE LIST OF DRILL SIZE, SPEED AND MATERIALS.....	14
X. ADJUSTMENTS .....	15
A. CHANGING BITS.....	15
B. CHANGING SPEEDS .....	16
C. SPINDLE ADJUSTMENTS .....	16
D. MORSE TAPER DRILL BITS .....	17
E. QUILL ADJUSTMENT .....	17
F. TABLE ADJUSTMENTS .....	17

<b>XI. MAINTENANCE</b> .....	<b>19</b>
<b>A. LUBRICATION</b> .....	<b>19</b>
<b>B. BELT TENSION</b> .....	<b>19</b>
<b>XII. TROUBLE SHOOTING</b> .....	<b>20</b>
<b>XIII. MACHINE DATA</b> .....	<b>21</b>
<b>XIV. CLOSURE</b> .....	<b>22</b>
<b>XV. PARTS DIAGRAM</b> .....	<b>23</b>
<b>XVI. PARTS LIST</b> .....	<b>24</b>
<b>XVII. WARRANTY AND RETURNS</b> .....	<b>25</b>
<b>XVIII. NOTES</b> .....	<b>26</b>



# I. INTRODUCTION

We are proud to bring you the Model G1201 Drill Press. The G1201 is designed to be one of the most versatile machines in your shop. It can perform many functions both as a wood and metalworking tool.

We are also pleased to provide this instruction manual with the Model G1201 drill press. This instruction manual was written to guide you through assembly, review safety considerations and cover general operating procedures. It represents our latest effort to produce the best documentation possible. If you have any constructive criticisms or comments that you feel we should include in our next printing, please write to us at the address below.

Manager, Technical Documentation  
Grizzly Imports, Inc.  
P.O. Box 2069  
Bellingham, WA 98227-2069

Finally, we stand behind our machines. We have two excellent regional service departments at your disposal should the need arise. If you have any service questions or parts requests, please call or write to us at the appropriate location listed below:

If you live West of the  
Mississippi River, contact:  
P.O. Box 2069  
Bellingham, WA 98227  
Phone (206) 647-0801

If you live East of the  
Mississippi River, contact:  
2406 Reach Road  
Williamsport, PA 17701  
Phone (717) 326-3806

As with any tool or machine, a thorough understanding of how this drill press operates is necessary for safe operation. Please take the time to read this manual thoroughly. If you do not understand something, **DO NOT** operate this machine. Contact us first for assistance or advice. Grizzly cautions that although our Safety Rules are extensive, they aren't necessarily comprehensive. The bottom line on safety is this: Make sure a setup or operation is safe *as it applies to your situation*.

We would also like to state that the specifications, drawings and photographs in this manual represent the Model G1201 as supplied when this manual was prepared. We are meticulous with our manuals; however, product changes or discrepancies can occur. Whenever possible, we send manual updates to all owners of a particular tool or machine. Should you receive one, please insert the new information with the old and keep it for reference.

We recommend that you keep a copy of our current catalog for complete information regarding Grizzly warranty and return policy. Should you need additional technical information relating to this machine, parts, or general assistance, please contact the appropriate regional service department.

We also believe additional information sources are very important to help you better realize the full potential of this machine. Trade journals, woodworking magazines, fellow woodworkers and your local library are all excellent sources.

Again, thanks for choosing Grizzly.

## II. SAFETY RULES FOR ALL TOOLS

There is a certain amount of danger associated with the use of this drill press. Operating it with respect and caution will considerably lessen the possibility of personal injury. If these safety precautions are ignored, consequences could be dire.

This machine should never be modified or used for any other purpose than that for which it was intended. As well as being dangerous, modifications or improper use of the Model G1201 will void all warranties.

1. **KNOW YOUR MACHINE.** Read the owner's manual carefully. Learn the machine's capabilities and limitations as well as the potential hazards associated with it.
2. **KEEP ALL GUARDS IN PLACE** and in working order.
3. **GROUND ALL NON-INSULATED TOOLS.** If the machine has a three-prong plug, it should be plugged into a grounded three-hole electrical receptacle. If an adapter is used to accommodate a two-prong receptacle, the adapter plug must be attached to a known ground. Never remove the grounding prong from the plug.
4. **REMOVE ADJUSTING KEYS AND WRENCHES.** Develop the habit of checking to see that keys and adjusting wrenches are removed from the machine before turning it on.
5. **KEEP WORK AREA CLEAN.** Cluttered areas and benches invite accidents.
6. **AVOID DANGEROUS ENVIRONMENTS.** Do not use power tools in damp or wet locations, or expose them to rain. Keep work area well lighted.
7. **MAINTAIN A SHOP "SAFE ZONE".** Keep all visitors a safe distance from the work area.
8. **MAKE WORKSHOP CHILD-PROOF.** Use padlocks, lockable master switches, or remove starter keys.
9. **DO NOT FORCE MATERIAL INTO THE MACHINE.** It will do the job better and safer at the rate for which it was designed.
10. **USE THE RIGHT TOOL.** Do not use a tool or attachment to do a job that it was not designed to do.
11. **WEAR PROPER APPAREL.** Do not wear loose clothing, gloves, neckties or jewelry that may get caught in moving parts. Non-slip footwear is also recommended. Wear a hat or hair-covering to contain long hair.
12. **USE SAFETY GLASSES AND EAR PROTECTION.** Also, use a dust mask or respirator if an operation produces dust.

13. **SECURE WORK.** Use clamps or a fixture to hold workpiece. It is safer than using your hand and frees both hands to operate the tool.
14. **DO NOT OVERREACH.** Keep proper footing and balance at all times.
15. **MAINTAIN MACHINE IN TOP CONDITION.** Keep cutting edges sharp and clean for safest, most accurate performance. Follow instructions for lubricating and changing accessories.
16. **DISCONNECT MACHINE** from power source and wait for all moving parts to stop before inspecting or servicing and before changing accessories.
17. **USE RECOMMENDED ACCESSORIES.** Refer to the current catalog for recommended accessories. The use of improper accessories may be hazardous.
18. **AVOID ACCIDENTAL STARTING.** Make sure switch is in the "OFF" position before plugging in power cord.
19. **NEVER STAND OR LEAN ON MACHINE.** Serious injury could occur if the machine is tipped or if the cutting edge is accidentally touched.
20. **INSPECT MACHINE BEFORE EACH USE.** Before each use of the machine, any part that is damaged should be repaired or replaced. Check for proper alignment, binding, mounting, and any other conditions that may affect machine operation. Perform maintenance service promptly when called for.
21. **DIRECTION OF FEED.** Always feed work into a blade or cutter *against* the direction of rotation of the blade or cutterhead.
22. **NEVER LEAVE MACHINE RUNNING UNATTENDED — TURN POWER OFF.** Do not leave machine until it comes to a complete stop.
23. **DO NOT OPERATE MACHINE WHILE UNDER THE INFLUENCE** of drugs, alcohol, or any medication that will affect your competence or judgement.
24. **DO NOT WORK IN HASTE** or operate machine if you are mentally or physically fatigued.
25. **IF THERE IS SOMETHING YOU DO NOT KNOW OR UNDERSTAND, DO NOT OPERATE MACHINE!** Ask for help first. Confusion can be dangerous.
26. **BAD HABITS ARE DANGEROUS.** Periodically review all safety procedures.

### III. UNPACKING

Your drill press has arrived in a carefully packed carton. If you find concealed damage after you've signed the delivery receipt and the truck and driver have left, you will need to file a freight claim with the carrier. Save the containers and all packing material for inspection by the carrier or their agent. Without the packing material, filing a freight claim could be difficult. If you need advice for this situation, please call us.

**CAUTION:** This drill press is a heavy unit. **DO NOT** over-exert yourself when lifting it out of its box; get help to lift this machine if necessary.

When you are completely satisfied with the condition of your shipment, you should now inventory its parts.

### IV. PIECE INVENTORY

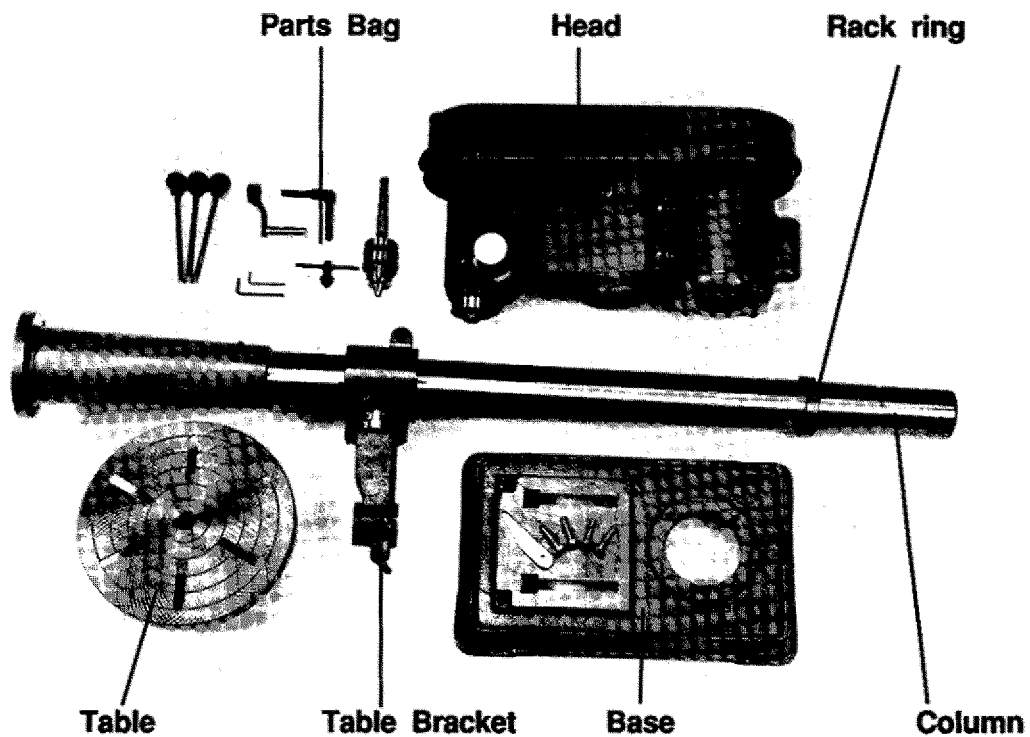

Figure 1

After all the parts have been removed from the container, you should have:

Table  
Column  
Base

Manual  
Head  
Parts Bag

**The parts bag is shipped inside the belt cover of the head.** In the event that any standard hardware is missing (e.g., a nut or a washer), we would be happy to replace it, but it would probably be quicker and less expensive for you to buy replacements from your local hardware store. However, if an unusual amount of fasteners or proprietary parts are missing, please let us know.

For your convenience, the following list describes the contents of the parts bag and where each part is needed. A complete parts list is found at the end of this manual.

Quantity	Description	Location
4	M12-1.75x40mm Bolt	Base
3	Handle Bar	Handle Body
1	Column Lock Handle	Bracket
1	Crank Handle	Worm Pinion
1	Chuck Arbor	Spindle
1	Chuck	Arbor

When you have completed your inventory, set the parts aside until they are ready for assembly.

## V. CLEAN UP BEFORE ASSEMBLY

The unpainted table surface may be sealed with a waxy coating (cosmolene) or an oily varnish to protect it from corrosion during shipment. The best way to remove either coating is with common paint thinner (mineral spirits) and clean rags. Do not use gasoline or petroleum-based products because of their extremely low flash points. Nor should you use chlorinated solvents such as perchloroethylene—if you happen to splash some onto a painted surface, you'll ruin the finish. Before cleaning, please keep in mind the following safety rules when working with solvents:

- Read and follow all directions and warnings on the solvent label.
- Work only in a well-ventilated area.
- **DO NOT** work near any type of open flame (e.g., pilot lights, kerosene heater).
- **DO NOT** smoke while working with flammable material.
- Paper towels or rags from the cleaning process are quite combustible. Dispose of waste towels so they do not create a fire hazard.

## VI. ELECTRICAL SERVICE REQUIREMENTS

Your Model G1201 drill press has a  $\frac{3}{4}$  HP, dual voltage 110/220V motor, which is pre-wired for 110V/120V, single phase operation. If you decide to operate this motor at a higher voltage, you will have to provide a 220/240V circuit.

### A. CIRCUIT LOADING

Your drill press draws 12 amps at 110V. This is not a large load; however, if the machine is operated on any circuit that is already close to its capacity, it might blow a fuse or trip a circuit breaker. If this happens, consider adding a dedicated circuit for your drill press. On the other hand, if an unusual load does not exist and power failure still occurs, have the circuit inspected by a qualified electrician.

### B. GROUNDING

**This equipment must be grounded.** Your drill press is supplied with a grounded power cord and plug. Please ensure that the drill press remains properly wired and grounded from the machine frame to a known ground. Verify that any existing outlet you intend to use is actually grounded. If it is not, it will be necessary to run a separate 14 AWG copper grounding wire from the outlet to a known ground. If adding a new circuit, please ensure that the circuit is grounded to the grounding terminal in your electric service panel.

### C. GENERAL INFORMATION

**Fusing:** Your drill press must be fused at 20 amps. Fuses rated any higher will not adequately protect this motor. Grizzly warns that equipment returned to us showing evidence of being improperly fused or wired will be repaired or replaced totally at the customer's expense, *regardless of the current warranty status.*

**Extension Cords:** If used, extension cords must be rated Hard Service (grade S) or better. Conductor size must be 14 AWG for cords up to 50 feet in length. Your extension cord must also contain a ground wire and plug pin. Always repair or replace extension cords if they become damaged.

### D. LIGHT

Your G1201 is equipped with a standard 110 volt lamp socket located between the spindle and the column. Maximum bulb wattage is 60 watts. Warning: if you operate this drill press on 220V you need to use a 220V light bulb or split the line for 110V to operate the light.

### E. WORD OF CAUTION

In this section we have covered some basic electrical requirements for the safe operation of your drill press. As with the safety rules in the preceding section, these requirements are not necessarily comprehensive. Further, you must be sure that your particular electrical configuration complies with state and local codes. The best way to ensure compliance is to check with your local municipality or a licensed electrician.

## VII. ASSEMBLY

Most of your G1201 drill press has been assembled at the factory. The few remaining pieces should go together quickly and easily. Assembly of your new drill press is quite straight forward and with a few tools you can do the entire job yourself.

The bottom of the column is bolted to the base. The rack is held in place on the side of the column by the bevel machined into the top of the column holder and the rack ring. A worm pinion gear is inserted inside the table bracket and meshes with another gear that engages the teeth in the rack. When the crank handle is turned the table bracket and table move up and down the column. This arrangement allows the table bracket, table and the rack to rotate around the column when you need to swing the table out of the way. The table can be securely locked into place with the column lock handle and the table lock handle. The head assembly contains the motor, pulley system and the spindle and quill arrangement that cause the chuck to rotate and permit it to move up and down. The head assembly is held securely in place on the top of the column by two setscrews.

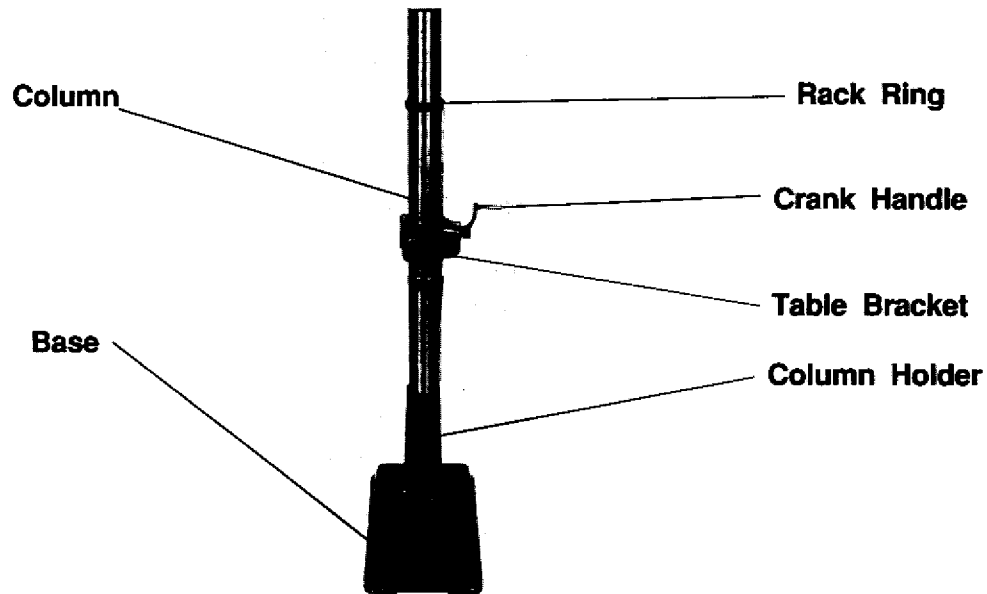

**FIGURE 2**

1. Place the base on the floor. Be sure the surface is flat and stable.
2. Place the column holder onto the base, line up the four holes and secure tightly with the four hex head bolts provided (See Figure 2).
3. Secure the column in the column holder by tightening the 6mm setscrew located on the back of the column holder.

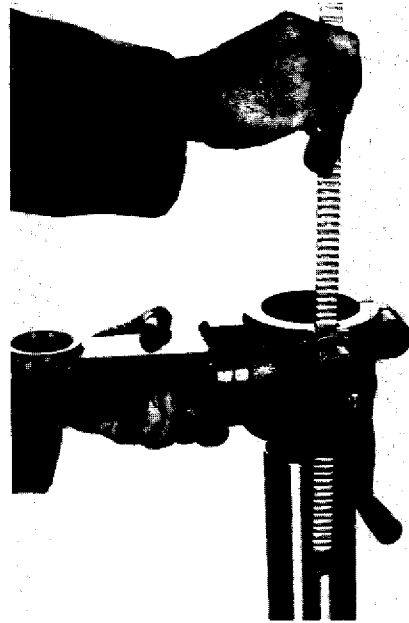

**FIGURE 3**

4. Insert the worm pinion inside the table bracket and attach the crank handle by tightening the setscrew.
5. The rack has a section with no teeth on each end. The end with the larger blank section is the top. Place the rack in the slot in the table bracket with the top facing up. Position it so the teeth mesh with the worm pinion. While holding it in that position, slide the table bracket and rack down the column until the bottom of the rack meets the base of the column (See Figure 3). The bevel in the rack should fit into the bevel in the top of the base.
6. Slide the rack ring down the column until it fits over the angled section at the top of the rack. Tighten the setscrew in the rack ring, leaving enough slack between the rack and the rack ring to allow the rack to move freely around the column (See Figure 4). **Do not overtighten or you may crack the rack ring casting.**
7. Place the head assembly onto the top of the column and lower it until it sits on the shoulder machined into the top of the column. **CAUTION:** The head assembly is quite heavy; get assistance when lifting.



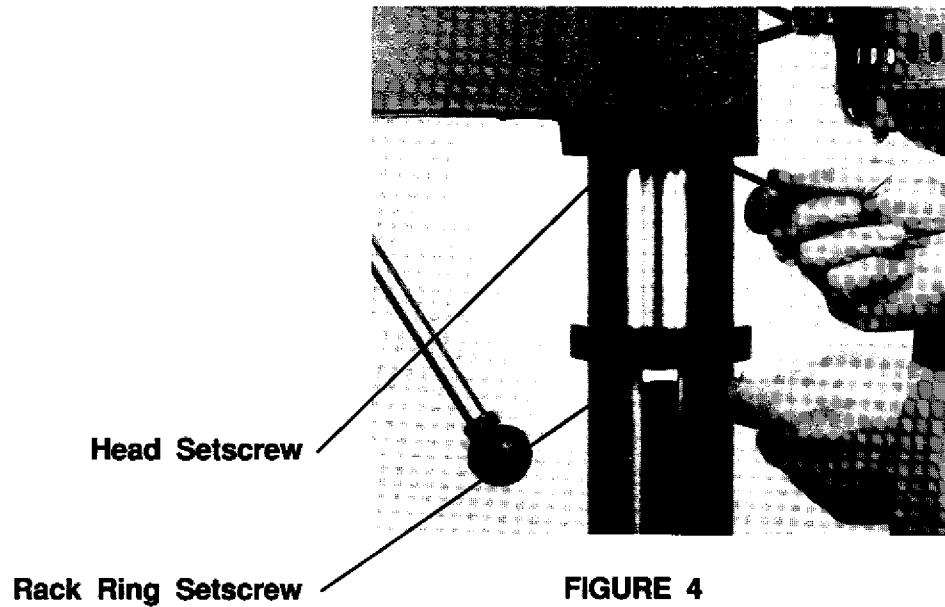

8. Secure the head to the column by tightening the 5mm setscrew (See Figure 4).
9. Place the table into the hole in the table bracket and secure with the handle (See Figure 5).

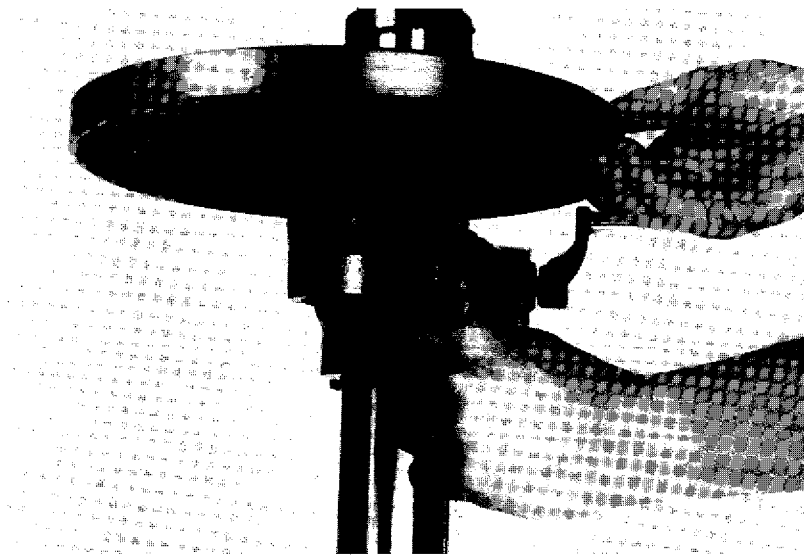

10. Turn the crank handle to be sure the worm pinion engages the teeth on the rack and moves the bracket up and down.
11. Screw the three handle bars into the tapped holes in the handle body.

## A. CHUCK INSTALLATION

The Model G1201 drill press chuck and arbor must be mounted in the drill press spindle. The arbor has a #6 Jacobs Taper on one end and a #3 Morse Taper on the other. The #6 Jacobs Taper fits into the drill chuck and the #3 Morse Taper fits in the drill press spindle. The arbor, chuck and drill press spindle fit together by friction fit. To mount the drill chuck on the drill press:

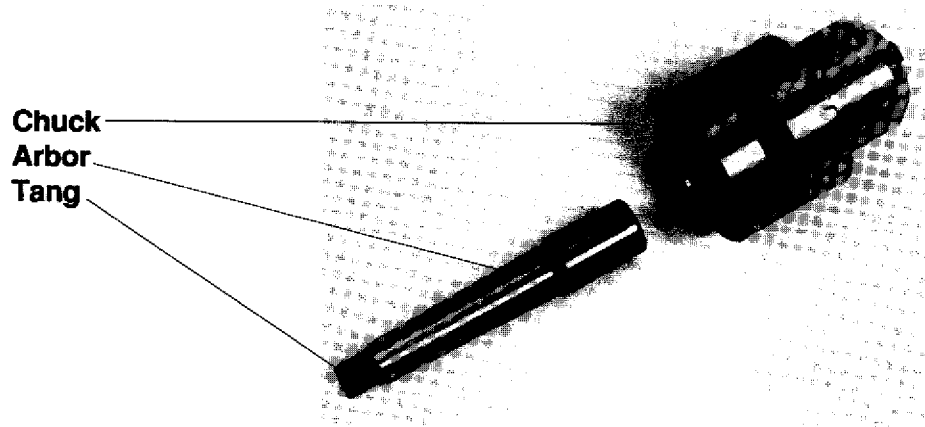

**FIGURE 6**

1. Thoroughly clean all of the shipping oil or cosmolene from both ends of the arbor, inside the drill chuck and the drill press spindle. Use mineral spirits and a rag.
2. Slide the arbor into the drill chuck and tap lightly with a soft hammer or block of wood.
3. Slide the arbor and chuck into the drill press spindle and turn it until the tang slips into the slot in the spindle.
4. While holding onto the drill chuck, tap lightly on the bottom of the chuck with a soft hammer or a block of wood. The drill chuck should now be quite snug in the drill press. If not, repeat steps 1-3, making sure all oil or cosmolene is removed.

## B. CHUCK REMOVAL

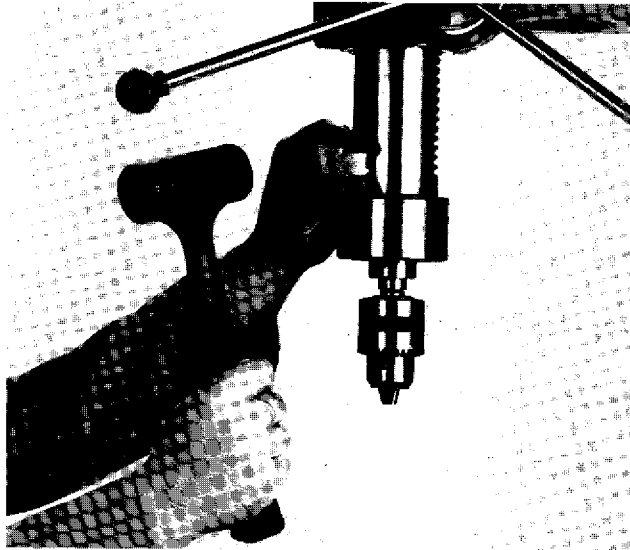

**FIGURE 7**

To remove the chuck and taper:

1. Adjust the stationary depth to three inches (see depth instructions).
2. Turn spindle manually, lining up the spindle and quill key hole.
3. Insert key through hole in spindle with the tapered edge facing down (See Figure 7).
4. When the tapered edge of the key contacts the top of the taper, hold the chuck with one hand and tap the key lightly with a hammer until the taper and chuck fall out. Do not allow the taper and chuck to fall onto the table.

## VIII. GETTING READY TO USE YOUR DRILL PRESS

Now that your drill press is assembled and in place, you are ready to begin using it. If used properly, your drill press is a safe and easy machine to operate. If used carelessly it can inflict serious injury. For your own protection, please read and follow these safety precautions.

- While operating this machine, do not wear jewelry, loose clothing, necklaces or neckties. Long sleeves on shirts should be rolled up or securely buttoned.
- Persons with beards and/or long hair should consider the use of a hat, hairnet or similar protective equipment.
- Always use face/eye protection when operating the drill press. A full face shield will afford the best protection followed by safety glasses with side shields.

- All adjustments or maintenance should be done with the power off and the drill press unplugged.
- Never use tools that are in poor condition. Cutting tools that are dull or damaged are difficult to control and may cause serious injury.
- Thoroughly clean the machine and surrounding area after use.
- Perform machine inspection and maintenance service.
- If you have questions about your drill press, ask a professional or an experienced user.
- Never attempt to clean wood or metal shavings from drill bits while the drill press is running.
- Workpiece must be held securely in place using a drill press vise or clamp.
- Never use a tapered shank bit or a square shank bit in a drill chuck.
- Use the correct speed for the size of bit and material being drilled.
- Always remove the key from the chuck before starting.
- Remove waste material with a brush, never by hand.
- Feed the drill bit evenly into the work piece. Back the bit out of deep cuts to cool and clean the bit.
- Never drill sheet metal unless securely clamped to the table.
- Work should be secured so as to avoid drilling into table.
- When changing speeds, disconnect machine from power source.

## **IX. OPERATIONS**

Your new drill press is a simple piece of equipment to set up and operate. It is a versatile tool that can be used to perform many different operations such as:

Drilling  
Sanding  
Shaping

Boring  
Mortising  
Machining

Drill press operation is simple, yet to become skilled, considerable practice is required.

## **A. GENERAL PROCEDURES**

1. Always wear safety glasses.
2. Secure workpiece using clamps or vise.
3. Select proper bit and speed according to material.
4. Adjust depth stop to desired position.
5. Drill hole with a smooth even pressure.
6. Cutting oil may be necessary for harder materials.
7. Turn machine off when not in use.

## **B. METAL**

For drilling in metal, use clamps to hold the workpiece securely in place. The workpiece should never be held in place by bare hands. The cutting edge can catch in the material at any time, resulting in injury. Any movement of the workpiece during the drilling operation may result in a rough or misplaced hole and increase the chance of drill bit breakage.

For flat work, lay the piece on a wooden base and clamp it firmly to the table. Use a V-block and clamp for round stock material. A drill press vise with prismatic jaws can also be used to hold flat or round material.

## **C. WOOD**

Twist bits, which are intended for metal may also be used for boring holes in wood. Machine spur bits are generally preferred, they cut a square bottomed hole and are designed for removal of wood chips. Do not use hand bits which have a screw tip; at drill press speeds they turn into the wood too fast and tend to lift the workpiece off the table and whirl it.

For through boring, line up the hole in the work table with the bit to avoid damaging it's tip. Scribe a vertical line on the column and a matching line on the table bracket so the table can be clamped in center position at any height. Use a piece of scrap wood under your workpiece and feed the bit into the wood slowly to prevent splintering the bottom side of the workpiece.

When using your drill press for operations such as shaping, sanding or mortising, use jigs, fixtures or hold downs that are appropriate and review the correct procedures with reference material pertaining to the specific application. The chuck will accept any tool with up to a  $\frac{5}{8}$ " shank. Do not attempt to open the chuck wider by forcing it.

## D. REFERENCE LIST OF DRILL SIZE, SPEED AND MATERIALS

Drill Diameter	Cast Iron	Steel	Aluminum	Wood
1/8"	1610	2470	2470	2470
3/16"	1550	1610	2470	2470
1/4"	730	1550	1550	2470
5/16"	730	730	1550	1550
3/8"	730	730	730	1550
7/16"	510	730	730	730
1/2"	510	510	730	730
9/16"	450	510	730	730
5/8"	370	510	510	730
3/4"	370	450	510	730
7/8"	290	370	370	510
1"		370	370	510
1 1/8"	290	370	370	
1 1/4"		370	390	

## X. ADJUSTMENTS

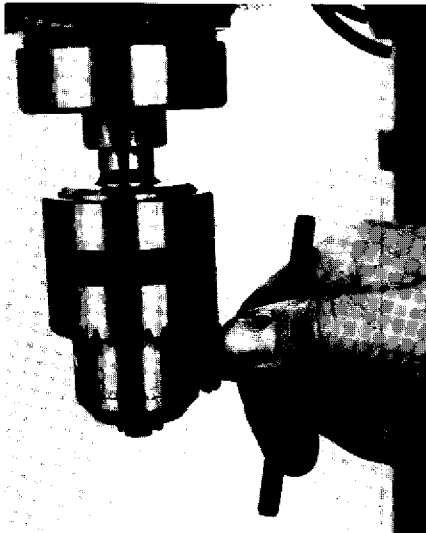

FIGURE 8

### A. CHANGING BITS

To insert or change a bit, care must be taken to secure the bit firmly in place.

When changing bits:

1. Disconnect the machine from the power source.
2. Open chuck wide enough to accept the new bit.
3. Install the bit so the chuck jaws will grab the major portion of the bit shank. Do not grab the body of the drill bit.
4. Tighten the chuck with the key using all key locations (See Figure 8).
5. **CAUTION:** Be sure to remove the key before reconnecting the power.

To remove bit:

1. Disconnect the machine from the power source.
2. Hold the bit with your left hand.
3. Turn the chuck key counter clockwise with your right hand to open the chuck.
4. Remove the bit.

It is a good practice to place a foam pad between the bit and the drill press table when changing bits to prevent breakage if the bit falls.

## B. CHANGING SPEEDS

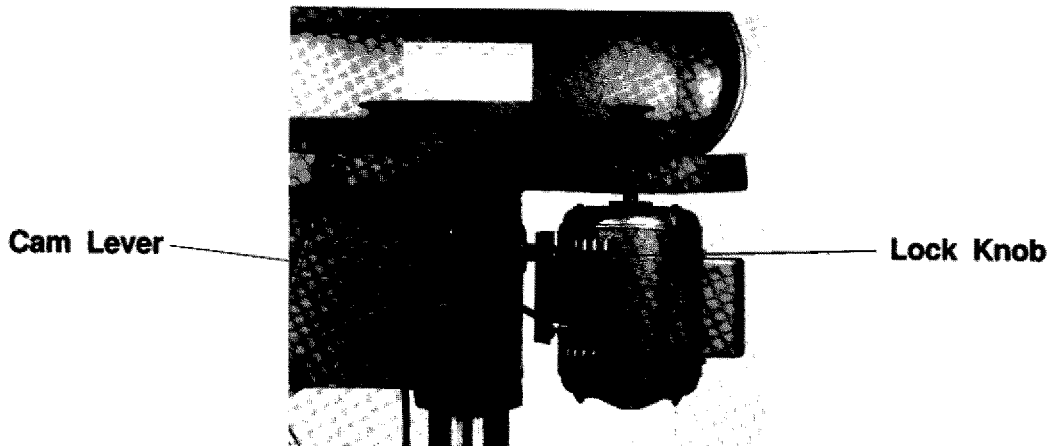

FIGURE 9

Remember to disconnect power source before attempting any adjustments.

1. To change speed, loosen the two lock knobs, one on either side of the head.
2. Turn cam lever so the motor pulley moves toward the center pulley.
3. Select the proper speed by referring to the chart inside the pulley cover. Move the belts into corresponding position for the selected speed.
4. Rotate the cam lever so the motor pulley moves away from the center pulley and tightens the belt.
5. While holding tension on the cam lever, tighten the locking screws on both sides of the head.
6. Close the cover.

**Note:** The speed chart under the pulley cover reflects two different power cycles for the motor. Use the 60 cycles per second spindle RPM in the USA.

## C. SPINDLE ADJUSTMENTS

To stop the drill at desired depth, loosen the scale setscrew located on the feed shaft assembly, lower the spindle to the desired depth and tighten the scale setscrew.

To hold a stationary depth, loosen the scale setscrew, and rotate the feed shaft to its lowest point. Then rotate the spindle to the desired depth and tighten the scale setscrew. This will lock the spindle at the desired depth.



## D. MORSE TAPER DRILL BITS

To use Morse Taper Drill Bits, you must remove the chuck and taper (See Page 11). Place the tapered bit into the spindle hole, push upward and twist until the bit is snug. Place a block of wood between the bit and the table then crank the table upward until the bit is firmly in place. Be sure the spindle taper and arbor are completely free of grease and dirt.

## E. QUILL ADJUSTMENT

On the front of the head casting are three cap screws. These are adjusted at the factory to minimize the play between the head casting and the quill. Grasp the chuck and move it from side to side. Note the play between the quill and the head casting. Too much play will result in inaccurate drilling operations while too little play will restrict the movement of the quill.

To adjust:

1. Loosen the two screws on the left.
2. Turn the screw on the right counterclockwise to reduce the play and clockwise to increase the play. This adjustment should be minor— $\frac{1}{4}$  turn at most.
3. Tighten the two screws on the left and test the play. Lower the spindle and release the handle—it should return to the full up position. Re-adjust if necessary.

## F. TABLE ADJUSTMENTS

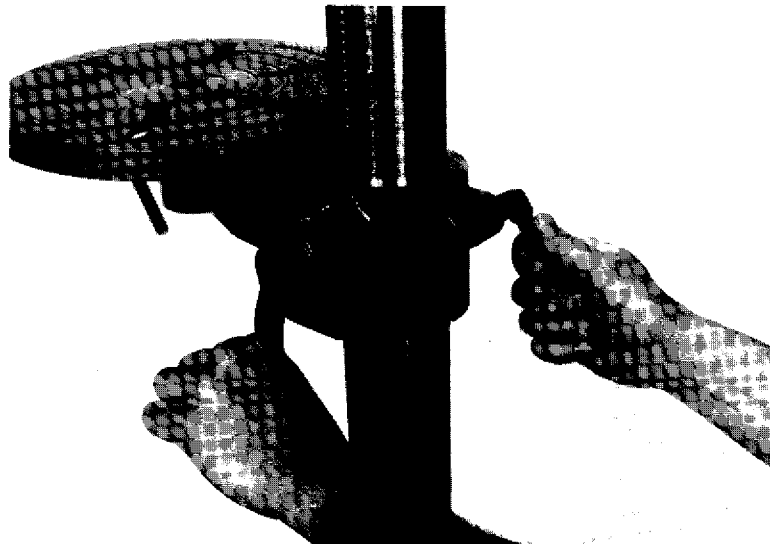
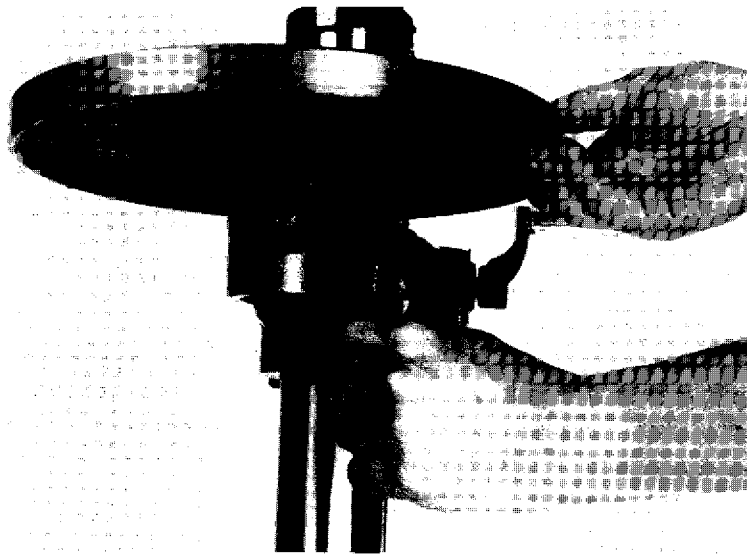

FIGURE 11

1. To adjust table up or down, loosen column lock handle and turn crank handle to desired height. Re-tighten column lock handle (See Figure 11).



**FIGURE 12**

2. To swing the table, loosen the column lock handle and swing the table to desired position. Re-tighten the column lock handle. For long workpieces, swing the work table 180° and use the base as your table.
3. To rotate table, loosen the table lock handle, rotate table to desired position and re-tighten table lock handle (See Figure 12).

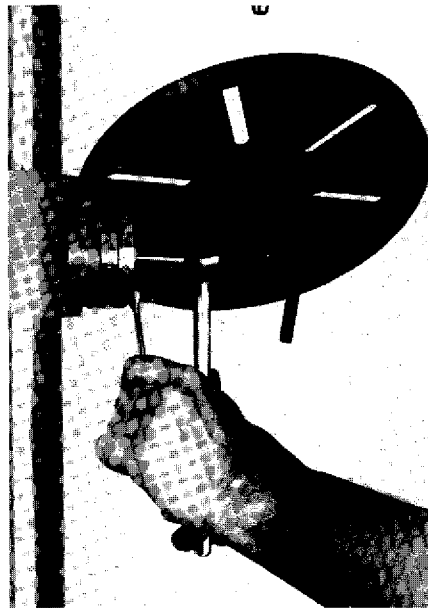

**FIGURE 13**

4. To tilt the table, loosen the pivot bolt and remove the locator pin (See Figure 13). To do this, tighten the nut until the pin easily slips out. Tilt the table to the desired angle (up to 45°) and re-tighten the pivot bolt. Re-insert the locator pin when returning the table to zero degrees.

# **XI. MAINTENANCE**

This machine requires very little in the line of routine maintenance. However, this does not mean "no maintenance". A little attention will ensure your equipment will operate accurately and dependably.

## **A. LUBRICATION**

Shielded, pre-lubricated ball bearings are used on this machine and lubrication is not required for the life of the bearing.

For other items on this machine, such as the quill, table, and column, an occasional shot of light machine oil is all that's necessary. Before applying lubricant, clean off sawdust and metal shavings. Use a light grease on the rack, both on the teeth and between the rack and column.

Your goal is to achieve adequate lubrication. Too much lubricant will attract dirt and sawdust and clog the drill press mechanism.

## **B. BELT TENSION**

Proper belt tension is achieved by tightening the belt adjusting cam so the belt has a slight tension on it. Excessive tension will create heat and shorten belt and bearing life. Too little tension will cause the belt to slip and squeal.

## XII. TROUBLE SHOOTING

**WARNING:** For your own safety, turn switch off and disconnect power source before troubleshooting.

Trouble	Probable Cause	Remedy
Noisy operation.	<ol style="list-style-type: none"><li>1. Incorrect belt tension.</li><li>2. Dry spindle.</li><li>3. Loose spindle pulley or motor pulley.</li></ol>	<ol style="list-style-type: none"><li>1. Adjust tension.</li><li>2. Lubricate spindle. See lubrication section.</li><li>3. Tighten setscrews in pulley.</li></ol>
Bit burns or smokes.	<ol style="list-style-type: none"><li>1. Incorrect speed.</li><li>2. Chips clogging hole.</li><li>3. Dull bit.</li><li>4. Feeding too slow.</li><li>5. Bit not lubricated.</li><li>6. Bit running backwards.</li></ol>	<ol style="list-style-type: none"><li>1. Select correct speed. See speed chart.</li><li>2. Retract bit frequently to clear chips.</li><li>3. Sharpen or replace bit.</li><li>4. Increase feed rate.</li><li>5. Lubricate bit.</li><li>6. Check motor rotation.</li></ol>
Excessive drill runout or wobble.	<ol style="list-style-type: none"><li>1. Bent bit.</li><li>2. Worn spindle bearings.</li><li>3. Bit improperly installed in chuck.</li><li>4. Chuck improperly installed.</li></ol>	<ol style="list-style-type: none"><li>1. Replace bit.</li><li>2. Replace bearings.</li><li>3. Install bit properly.</li><li>4. Install chuck properly.</li></ol>
Drill binds in workpiece.	<ol style="list-style-type: none"><li>1. Workpiece pinching bit or excessive feed pressure.</li><li>2. Improper belt tension.</li></ol>	<ol style="list-style-type: none"><li>1. Support or clamp workpiece.</li><li>2. Adjust belt tension.</li></ol>
Workpiece torn loose from hand.	<ol style="list-style-type: none"><li>1. Not supported or clamped properly.</li></ol>	<ol style="list-style-type: none"><li>1. Support or clamp workpiece.</li></ol>

# XIII. MACHINE DATA

## GRIZZLY MODEL G1201 DRILL PRESS

Design Type ..... Floor Model

### Overall Dimensions:

Table Size ..... 15" Round  
Height ..... 68"  
Overall Width ..... 15"  
Over all Depth ..... 32"  
Shipping Weight ..... 330 lbs.  
Weight (In place) ..... 320 lbs.

### Construction:

Table ..... Precision Ground Cast Iron  
Column ..... Precision Ground Cast Iron  
Base & Head ..... Cast Iron

### Motor:

Type ..... TEFC Capacitor Start Induction  
Horsepower ..... 3/4 HP  
Phase Type/Cycle ..... Single Phase/ 60 Hz  
Voltage ..... 110V/220  
Amps ..... 12/6  
RPM ..... 1720 RPM  
Switch ..... Power / Light  
Power Transfer ..... Belt Drive  
Bearings ..... Shielded & Permanently Lubricated Ball

### Capacities:

Spindle Travel ..... 5"  
Maximum (Spindle to Base) ..... 46"  
Maximum (Spindle to Table) ..... 25"  
Spindle Taper ..... M. T. #3  
Chuck Size ..... 5/8"  
Speeds ..... 9  
Range of Speeds ..... 150-2470 RPM

### Features:

Built in light (110V 60 Watt Maximum) - Table tilts 90° Left or Right, swings 360° - Positive table lock - Worm geared table adjustment

*Specifications, while deemed accurate, are subject to change without notice.*

## **XIV. CLOSURE**

The following pages contain general specifications, a parts diagram, a parts directory and warranty and return information for your Model G1201 drill press.

You are welcomed and encouraged to write or call the appropriate regional service department if you ever need parts or service assistance. Our service staff will be glad to help you. If you wish to comment on this manual, please write to our Bellingham, Washington location.

Again, thank you for your purchase. We sincerely appreciate your business and hope we have the opportunity to serve you again soon.

# XV. PARTS DIAGRAM

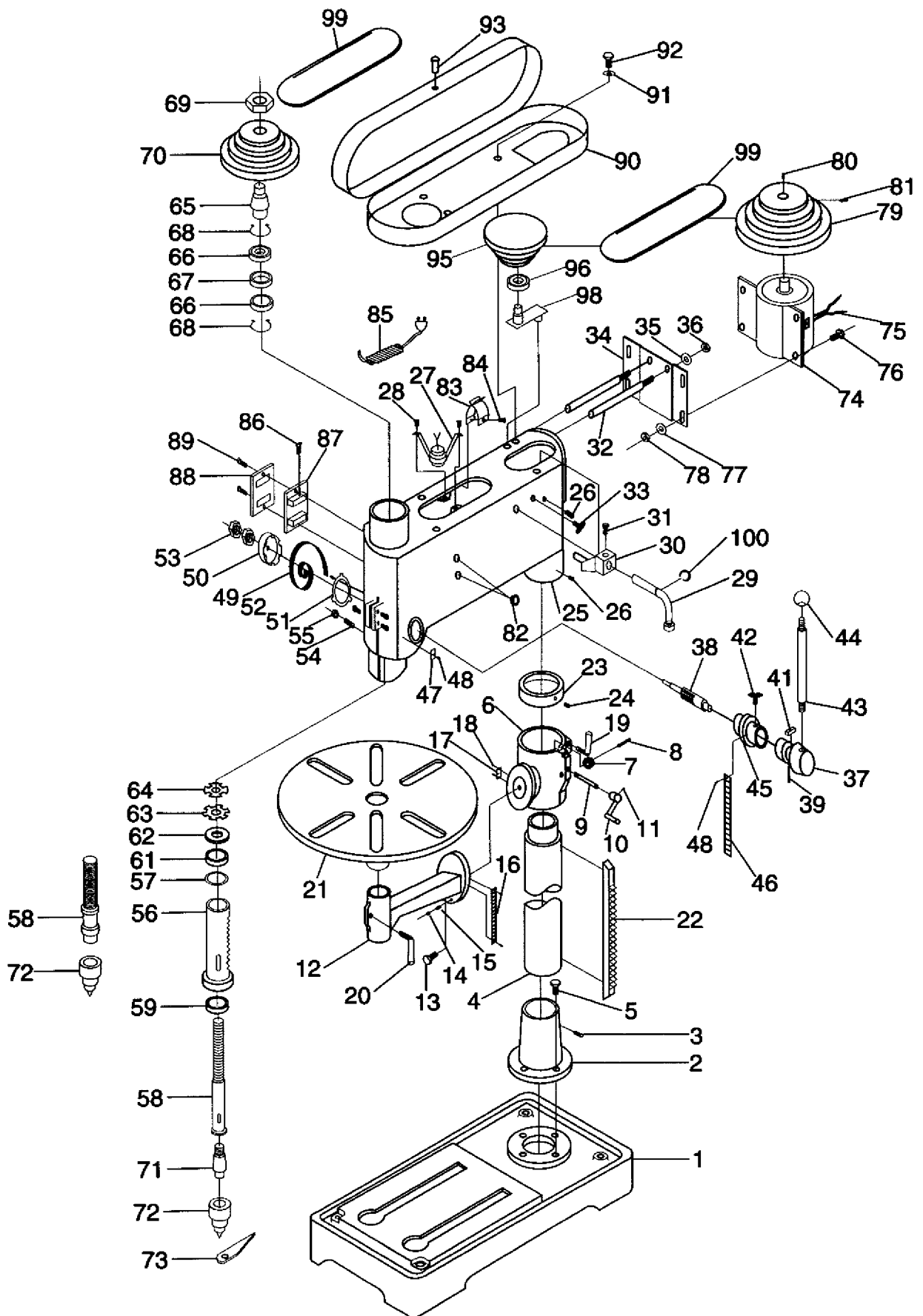

## XVI. PARTS LIST

Part Ref.#	Part #	Description	Part Ref.#	Part #	Description
01	P1201001	Base	53	PN01	1/2"-20 Hex Nut
02	P1201002	Column Holder	54	P1201054	Quill Setscrew
03	P1201003	Setscrew	55	PN02M	10-1.5 Hex Nut
04	P1201004	Column	56	P1201056	Quill
05	PB37	M12-1.75 x 40mm Bolt	57	P1201057	Rubber Washer
06	P1201006	Bracket	58	P1201058	Spindle Shaft
07	P1201007	Pinion Gear	59	P6205	Ball Bearing 6205
08	P1201008	Gear Shaft	61	P6203	Ball Bearing 6203
09	P1201009	Worm Pinion	62	P1201061	Special Washer
10	P120101	Crank Handle	63	P1201063	Special Locknut
11	PB18M	M 6-1.0 x 15 Bolt	64	P1201064	Spindle Shaft Nut
12	P1201012	Table Bracket	65	P1201065	Drive Sleeve
13	PB45	5/8" - 11 x 1 1/2" Bolt	66	P6205	Ball Bearing 6205
14	P1201014	Locator Pin	67	P1201067	Collar
15	PN05	1/4" - 20 Hex Nut	68	P1201068	Special Snap Ring
16	P1201016	Angle Scale	69	PN10M	LH M25-1.5 Hex Nut
17	P1201017	Centering Scale	70	P1201070	Pulley
18	P1201018	Rivet	71	P1201071	Arbor
19	P1201019	Column Lock Handle	72	P1201072	Chuck
20	P1201020	Table Lock Handle	72A	P1199072A	5/8" Chuck Key
21	P1201021	Table	73	P1199073	Wedge Shifter
22	P1201022	Rack	74	P1201074	Motor
23	P1201023	Rack Ring	75	P1201075	Wire
24	PSS03M	M 6-1.0 x 8 Setscrew	76	PB09M	M8-1.25 x 20 Bolt
25	P1201025	Head Casting	77	PW07	5/16" Flat Washer
26	PSS13M	10M-1.5 x 12 Setscrew	78	PN03M	M8-1.25 Hex Nut
27	P1201027	Lamp Socket	79	P1201079	Motor Pulley
28	PB02M	M 6-1.0 x 12 Bolt	80	P1199080	Key 5x5x37mm
29	P1201029	Cam Handle	81	PSS01M	M6-1.0 x 10 Setscrew
30	P1201030	Cam	82	P1201082	Wire Insulator
31	PB03M	M 8-1.25 x 16 Bolt	83	P1201083	Wire Clip
32	P1201032	Slide Bar	84	P1201084	Clip Screw
33	P1201033	Slide Bar Bolt	85	P1201085	Cord
34	P1201034	Motor Base	86	P1201086	Clip Terminal
35	P1201035	12mm Lockwasher	87	P1199087	Switch
36	PN09M	M 12-1.75 Hex Nut	88	P1201088	Switch Cover
37	P1201037	Handle Body	89	PS08M	M5-0.8 x 12 Screw
38	P1201038	Feed Shaft	90	P1201090	Pulley Cover
39	P1201039	Feed Shaft Set Pin	91	PW06	1/4" Flat Washer
40	P1201040	Scale Guide Pin	92	PS11M	M8-1.25 x 24 Screw
41	P1199041	Scale Guide	93	P1199093	Cover Knob
42	P1201042	Scale Set Handle	95	P1201095	Center Pulley
43	P1201043	Handle Bar W/44	96	P6202	Ball Bearing 6202
44	P1201044	See P1201043	97	P1201097	Ring Spacer
45	P1201045	Spindle Depth	98	P1201098	Center Pulley Shaft
46	P1201046	Scale	99A	PVB030	V Belt A-30
47	P1201047	Spindle Centering Scale	99B	PVB033	V Belt A-30
48	P1201048	Setscrew			
49	P1201049	Spring & Housing			
51	P1201051	Spring Seat			
52	P1201052	Spring Seat Setscrew			



## **XVII. WARRANTY AND RETURNS**

### **Limited Warranty**

Grizzly Imports, Inc. (Grizzly) warrants every product it sells for a period of 90 days on all parts and one year on all electric motors to the original purchaser from the date of purchase. This warranty does not apply to defects due directly or indirectly to misuse, abuse, negligence, accidents, repairs or alterations or lack of maintenance. This is Grizzly's sole written warranty and any and all warranties that may be implied by law, including any merchantability or fitness, for any particular purpose, are hereby limited to the duration of this written warranty. We do not warrant or represent that the merchandise complies with the provisions of any law or acts unless the manufacturer so warrants. In no event shall Grizzly's liability under this warranty exceed the purchase price paid for the product and any legal actions brought against Grizzly shall be tried in the State of Washington, County of Whatcom.

We shall in no event be liable for death, injuries to persons or property or for incidental, contingent, special or consequential damages arising from the use of our products.

To take advantage of this warranty, the product or part must be returned, freight prepaid to either our Bellingham or Williamsport warehouse. Proof of purchase must accompany the merchandise. The manufacturers reserve the right to change specifications at any time as they constantly strive to achieve better quality equipment.

We make every effort to ensure that our products meet high quality and durability standards and we hope you never need to use this warranty.

## **XVIII. NOTES**

# Parts and Service Information

Grizzly stands behind its products with a full parts inventory. These parts are available for purchase by Grizzly machine owners regardless of whether you are the original owner or a subsequent owner. If you are the original owner, please fill out the warranty information on the warranty card, remove the card from this manual and send it back to us within 10 days of product delivery. We appreciate any comments or suggestions and use them to better our products and service.

If you are not the original owner, please fill out one of the cards below, remove the card from the manual and send it back to us. By registering with us, you will have the same access to parts and service as the original owner.

If you need service or help with this machine, please call or write to us at the appropriate regional service location listed on page 1 of this manual.

## CHANGE OF OWNERSHIP

### Original Owner

Machine name & model no. \_\_\_\_\_

Name \_\_\_\_\_ Phone Number \_\_\_\_\_

Street \_\_\_\_\_

City \_\_\_\_\_

State \_\_\_\_\_ ZIP \_\_\_\_\_ Date purchased \_\_\_\_\_

### New Owner

Name \_\_\_\_\_ Phone Number \_\_\_\_\_

Street \_\_\_\_\_

City \_\_\_\_\_

State \_\_\_\_\_ ZIP \_\_\_\_\_ Date purchased \_\_\_\_\_

## CHANGE OF OWNERSHIP

### Original Owner

Machine name & model no. \_\_\_\_\_

Name \_\_\_\_\_ Phone Number \_\_\_\_\_

Street \_\_\_\_\_

City \_\_\_\_\_

State \_\_\_\_\_ ZIP \_\_\_\_\_ Date purchased \_\_\_\_\_

### New Owner

Name \_\_\_\_\_ Phone Number \_\_\_\_\_

Street \_\_\_\_\_

City \_\_\_\_\_

State \_\_\_\_\_ ZIP \_\_\_\_\_ Date purchased \_\_\_\_\_

From:

\_\_\_\_\_  
\_\_\_\_\_  
\_\_\_\_\_

PLACE  
STAMP  
HERE



GRIZZLY IMPORTS INC

P O BOX 2069

BELLINGHAM WA 98227-2069

From:

\_\_\_\_\_  
\_\_\_\_\_  
\_\_\_\_\_

PLACE  
STAMP  
HERE



GRIZZLY IMPORTS INC

P O BOX 2069

BELLINGHAM WA 98227-2069