

Introduction

The LQ500 density (consistency) meter uses microwave phase shift technology to determine concentrations of solids in the material to be measured flowing through pipes. It can perform a stable and realtime density (consistency) measurement because this technology is not affected by flow velocity along with fluid color, and also is not easily affected by contaminants and low process pressure rate. As the LQ500 has no moving parts, it is reliable and virtually maintenance free.

Since the output of the LQ500 is theoretically linear, it can be applied to a wide range of density (consistency) measurement.

<Notice>

The LQ500 requires a full pipe to measure the density (consistency). Contact Toshiba before installation in the following cases:

<Possibility of unfilled condition>

- (a) When it is installed at the discharge of a pump.
- (b) When installation is horizontal, and unfilled condition occurs inside the pipe.
- (c) A process where the pipe becomes unfilled when the operation is stopped.

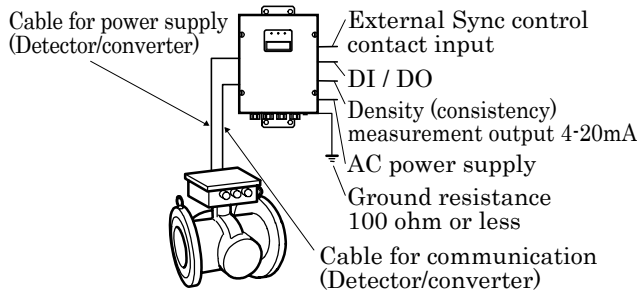

Figure 1. LQ500 Configuration Diagram

■ Standard Configuration

- **Density (Consistency) Meter:** 1 set (Detector and converter separate mounted)
- **Accessories:** 1 set (see Table 1 below)

Table 1. Standard Accessories

Items	Specifications	Quantity
Power supply cable	Between detector and converter (*1)	10 m (32.8 ft)
Communication cable	Between detector and converter (*1)	10 m (32.8 ft)
Fuse	2A(T), 250 V (glass tube, 5.2 dia. x 20 mm)	2
Document	Instruction manual	1

Note 1: Need to prepare a power supply cable for the LQ500. Refer to the section of cable specifications at the overall specifications in detail.



Figure 2. LQ500 Density (consistency) Meter



Specifications

■ Overall Specifications

Measurement method:

Microwave phase difference method

Measurement range:

Meter size	50 mm (2")	80 to 300 mm (3" to 12")
Span (*2)	2 to 50 %TS (*1)	1 to 50%TS (*1)
Lower limit setting range (4 mA)	0 to 48%TS	0 to 49%TS
Upper limit setting range (20 mA)	2 to 50%TS	1 to 50%TS
Setting increments	0.1%TS	

*1 TS: Total Solids

*2 Span = Upper range – Lower range

*3 The material to be measured must be fluid and be filled evenly with no voids.

Repeatability:

Meter size	50 mm (2")	80 to 300 mm (3" to 12")
Repeatability	±0.02%TS	±0.01%TS

Note 1 : Above values are the results of commuting ability in the phase measurements of the converter.

Note 2 : Density (consistency) determination repeatability for sample reagent;

Meter size		50 mm (2")	80 to 300 mm (3" to 12")
Density (consistency) determination repeatability	For the full scale value of 2%TS or greater	±2%FS	±2%FS
	For the full scale value of less than 2%TS		±4%FS

*The characteristics of sample reagent has errors due to sample tests such as uneven density (consistency) distribution.

*Full scale is the maximum value in the measurement

range, which is the upper limit setting range.

Resolution:

Meter size	50 mm (2")	80 mm (3")to 300 mm (12")
Resolution	0.002%TS	0.001%TS

Note 1: Above values are the results of commuting ability in the phase measurements of the converter.

Note 2: Density (consistency) determination resolution for sample reagent;

Meter size	50 mm (2")	80 mm (3")to 300 mm (12")
Density(consistency) determination repeatability	0.1%TS	0.05%TS

* The density (consistency) determination resolution stated above is defined due to manufacturing limitation to make reagents with stable distribution and a minimum difference of fluid density (consistency).

<Notice>
1. Install a sample tap near the LQ500 as close as possible to get an accurate density (consistency) measurement using the LQ500.
2. Take several samples in rapid sequence for more accurate density (consistency) measurement with less human error factors.

Environmental conditions:

Items	Temperature range	Humidity range
Detector	Standard: 0 to 50 deg.C (32 to 122 deg.F)	5 to 85%RH (no condensation)
	Option: -20 to 50 deg.C (4 to 122 deg.F) (*1)	
Converter	0 to 50 deg.C (32 to 122 deg.F)	

*1 A rubber heater is installed at the RF part of the detector.
 Need to prepare an additional power supply either 100Vac type or 200Vac type for it by yourself. Determine one of them at the specification code. This option is available for detector only.

Structure: Converter:IP65,

Detector:IP67, Watertight

Note: Outdoor installation is possible. However, provide a sunshade for the converter section if direct sunlight is unavoidable.

Microwave power: 10 mW

Vibration resistance:

No resonance to the following levels of vibration:

- (1) No failure for 5 to 150 Hz with the following acceleration in each device for 30 minutes in each axis of X, Y, and Z (90 minutes); Converter: 4.9 m/s², Detector: 25m/s²
- (2) No failure for 5 to 150Hz with the following acceleration in each device for 3 minutes in each axis of X, Y, and Z, 10 times (90 minutes as total); Converter: 4.9 m/s², Detector: 25m/s²

Note: Avoid using the LQ500 in an environment with constant vibration.

Cables: See the Table 2

Table 2. Cable specifications

Specifications	Cables Between detector (RF part)and converter (*1)		Power supply cable of LQ500 (*2)
	Power supply (24Vdc)	Communi-cation	
Cable type	CVVS-2C-2S	CVVS-5C-1.25S	CVV-3C-2S
Cross-sectional area (*3)	2 mm ²	1.25 mm ²	2 mm ²
Number of cores	2	5	3
Cable diameter (*4)	11 to 13 mm ²	11 to 13 mm ²	11 to 13 mm ²

*1 10m (32.8 ft) length is packed as standard.

*2 Need to prepare this cable by the customer.

*3 Need to use a sheathed cable.

*4 If the diameter of the cable is smaller than the inside diameter of the packing, enlarge the cable diameter to the same size as the packing by wrapping around the cable.
 This dimension is coming from a diameter of the cable gland of the LQ500.

Conformance to European Community Directives:

- EMC directive 89/336/EEC
- The low voltage 93/68/EEC
- PED 97/23/EC (Note 1)

Note: See table 6 in detail.

Approved hazardous locations certification:

UL/CUL Class I, Division 2, Groups A, B, C and D (UL/CULonly for explosion proof)

Weight: Refer to Outline Dimensions (Table 3).

Part 15 of the FCC rules: Certified.

Detector Specifications

Meter size: 50mm (2"), 80mm (3"), 100mm (4"), 150mm (6"), 200mm (8"), 250mm (10"), and 300mm (12")

Flange standard and maximum working pressure:

Flange standard	Maximum working pressure
ANSI Class 150	1 MPa (150 psi)
DIN10 and BS10	1 MPa (10 bar)
DIN 16	1.6 MPa (16 bar)
JIS 10K	1 MPa (10 kgf/cm ²)

Note: Each product was passed a hydraulic test under twice pressure rate for 15 minutes toward the specification.

Fluid temperature:

0 to 100 deg.C (32 to 212 deg.F) without freezing and bubbles conditions

Allowable fluid conductivity:

Meter size	Fluid conductivity
50 mm (2")	20 mS/cm maximum
80 mm (3")	16 mS/cm maximum
100 mm (4")	15 mS/cm maximum
150 mm (6")	10 mS/cm maximum

200 mm (8")	8 mS/cm maximum
250 mm (10")	8 mS/cm maximum
300 mm (12")	6 mS/cm maximum

Note 1: The LQ500 can not have an accurate density (consistency) measurement when it is over the specification according to reduce the microwave signal.

Note 2: The LQ500 density (consistency) measurement for application where liquids containing highly conductive particles such as active carbon and metal particles may be affected. Consult Toshiba for detail when the measuring liquid contains such particles.

Wetting materials:

Name	Materials (*1)
Main pipe	SCS14A cast (equivalent to 316 SS) (standard) (*2, *3)
Temperature detector sheath	316 stainless steel (*4)
Applicator window	Polysulfone (*4)
Applicator window sealant	Fluoric rubber

*1 Avoid using the LQ500 for applications where harmful liquids that cause corrosion, deterioration, or changes in quantity for the wetting materials are used. Make sure all materials at these wetting parts that are suitable for your CIP or not before cleaning.

*2 The smoothness inside the pipe on this material is;

Type	Meter size	Smoothness
Standard type	50 to 200 mm (1/2" to 8")	No buffing
	250 & 300 mm (10" & 12")	Buffing # 150
Option type	50 to 300 mm (1/2" to 12")	Buffing # 150

*3 State the wetted materials when you choose these options.

*4 The materials of them are changed for abrasive applications. Need to choose the specification code for this application.

Applicator:

Serves as an antenna to send and receive microwave signals, one set provided.

Temperature detector: RTD (Pt100)

Fitting:

Direct fitting to vertical or horizontal piping. (Refer to the section of Piping Precautions.)

■ Converter Specifications

Output signals

- **Density (consistency) measurement output:** 4-20mA_{dc} (load resistance 750 ohm maximum, isolated output.)
- **Density (consistency) fault or Maintenance signal:** 125V_{ac}, 0.1A (resistive load) solid state contact; opens when an error occurs in the converter or when the LQ500 is in the setting change mode, otherwise the contact remains closed.

Communication signal:

Digital signal is superimposed on 4-20mA_{dc}

current signal (conforming to HART protocol(*1)).

Load resistance: 240 to 750 ohm

Load capacity: 0.25μF maximum

*1 HART (Highway Addressable Remote Transducer) protocol is a communications protocol for industrial sensors recommended by HCF (HART Communication Foundation).

Note: The optional AF900 hand-held terminal can be used to operate the LQ500 from remote places by connecting the AF900's probe lead between the LQ500's 4-20 mA dc output signal lines.

Input signals

• External synchronized input signal:

In order to avoid problems of density (consistency) measurement such as inhomogeneous condition caused by discontinuous process operation and empty pipe condition caused by stopping process operation.

<Specification>

One dry "make" contact;

Contact capacity of 24V_{dc} with 0.1 to 2.0A is required.

This contact signal can be used to start or stop density (consistency) measurement in synchronization with an external contact, such as the contacts on a pump.

The measurement starts or stops as follows:
Contact closed: Starts density (consistency) measurement.

Contact open: Stops density (consistency) measurement.

• Density multiplier switching signal:

In order to achieve selecting up to 4 kinds of liquid concentration measurement independently as maximum.

<Specification>

Two voltage signals described below are required:

Input voltage: H level: 20 to 30 V_{dc}
L level: 2 V_{dc} or less

Input resistance: Approx. 3k ohm

• Conductivity correction signal:

Need to prepare an additional conductivity meter when using this function. Install in where is able to have a stable and accurate measurement.

<Specification>

Input signal: 4 to 20mA_{dc}
Conductivity range: 0 to 10mS/cm

Update period for density (consistency) measurement output and display:

Approx. 1 second

Functions by software as standard:

• Data saving function:

In order to save measurement data into the memory of converter temporary. The oldest data is overwritten.

<Specification>

Data storage points: 256 points maximum.

Period: 1 to 1,800 minutes (1 minute each).

ex 1: The data is saved for approx. latest 4.26 hours when programming every minute.

ex 2: The data is saved for approx. latest 21.3

hours when programming every 5 minutes.

- **Moving average function:**
In order to keep the average density (consistency) output, or in order to suppress the deflection width of the output. It helps for density (consistency) control.
<Specification>
Enable to determine a number from 1 to 99.
- **Change-rate limit function:**
In order to reject the transient density (consistency) output as noises, or a sudden variation in the output according to intrusion by bubbles, etc....
<Specification>
Allowable rate of change limit: 0.00 to 9.99%TS
Enable to determine a number from 0 to 99.
- **Additive correction function:**
Available for up to 10 kinds of mixed / blended liquids. Sensitivity compensation can be set using registered parameters depending on the type and the mixing rate of liquids.
- **Password function:**
This function is used to limit access to changing parameters that affect measured data by means of a password.

Arrestor:

Arrestors are installed in the LQ500 current output (4-20mA_{dc}) and AC power lines.

Operation panel and Display:

Used to check data or change various settings.
Operation switches: 5 switches.
Display: 4-line, 20-character LCD (dot-matrix) with backlight.

Power supply:

100 to 240Vac 50/60Hz (Allowable voltage: 85 to 264Vac)

Note: An additional power supply is required when choosing an optional environmental temperature specification type (-20 to 50 deg.C). Refer to the section of Environmental conditions in detail.

Note2: UL/CUL Hazardous locations type does not have a power switch. Please prepare a power switch outside. (Rated 250V AC,10A above, DPST: Double-Pole/Single-Throw)
Use the power switch for Hazardous locations in Hazardous locations area.

Power consumption: Approx. 25VA (100Vac),
Approx. 35VA (240Vac)

Housing material: Steel plate

Coating: Polyurethane

MTBF: 135.8 months under 25 deg. C (77 deg. F) based on MLL-HDBK-217F

Installation

■ **Outline Dimensions**

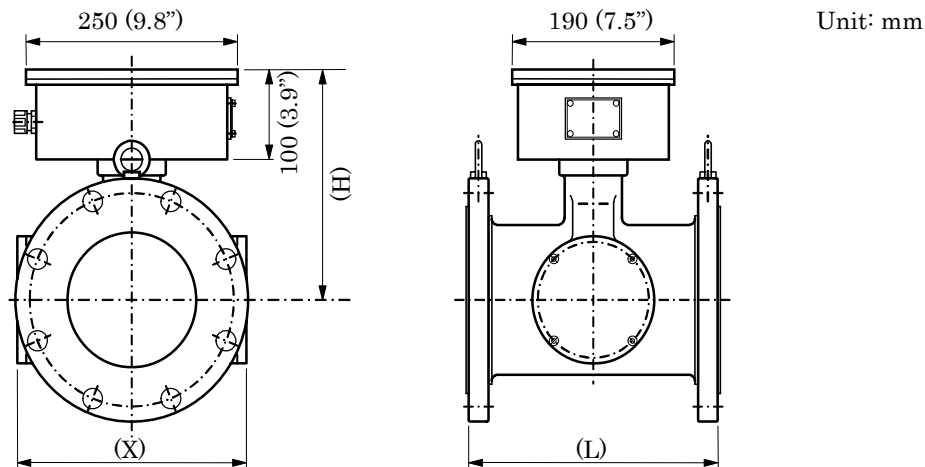

Figure 3. LQ500 detector outline dimensions

Table 3. LQ500 detector outline dimensions

Size (mm)	X (mm)	H (mm)	L (mm)	Weight (kg)		
				DIN 16	ANSI 150	JIS 10K
50 (2")	170 (6.7")	225 (8.9")	300 (11.8")	Approx.22	Approx.21 (46 lb)	Approx. 21
80 (3")	200 (7.9")	225 (8.9")	300 (11.8")	Approx.30	Approx.31 (68 lb)	Approx. 26
100 (4")	220 (8.7")	240 (9.4")	300 (11.8")	Approx.31	Approx.34 (75 lb)	Approx. 29
150 (6")	270 (10.6")	260 (10.2")	300 (11.8")	Approx.43	Approx.44 (97 lb)	Approx. 42
200 (8")	320 (12.6")	290 (11.4")	300 (11.8")	Approx.52	Approx.54 (119 lb)	Approx. 48
250 (10")	300 (11.8")	315 (12.4")	350 (13.8")	Approx.68	Approx.68 (150 lb)	Approx. 64
300 (12")	360 (14.2")	340 (13.4")	350 (13.8")	Approx.85	Approx.99 (218 lb)	Approx. 76

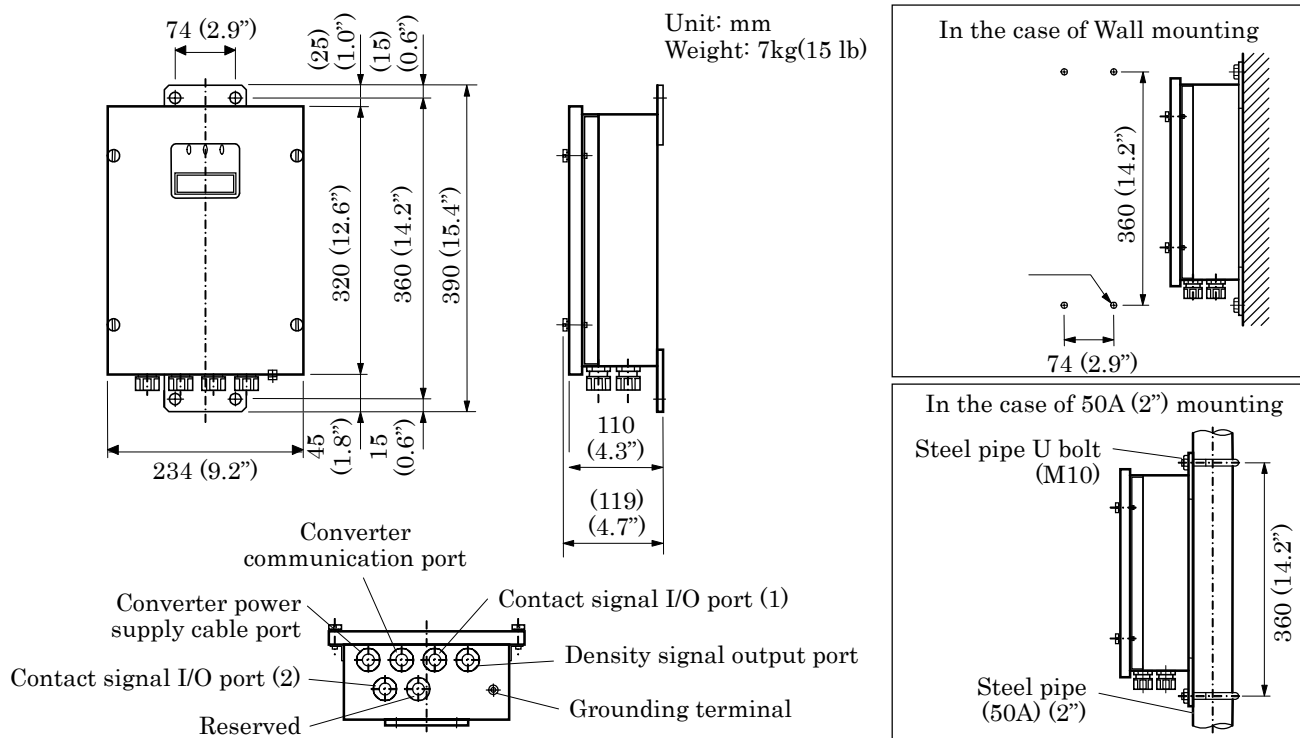

Figure 4. LQ500 Converter outline dimensions

■ Installation Precautions

- (1) Install the LQ500 in an environment free from vibration and corrosive gases and in a place which allows easy on-site maintenance.
- (2) Provide a clearance space both detector and converter to the front, rear, and above the unit. See Figure 5.
- (3) Provide a sunshade for the detector and converter if direct sunlight is unavoidable when installing outdoors.
- (4) The LQ500 cannot be installed in an environment where there is a possibility that flammable or explosive gases may leak.
- (5) The LQ500 should avoid the following environmental installations:
 - Places where condensation accumulates due to sudden temperature changes.
 - Places of low or high temperature that is out of the specification.
 - Places near equipment that produces strong electric waves or electrolytes.
 - Places where flammable or explosive gas may be generated.

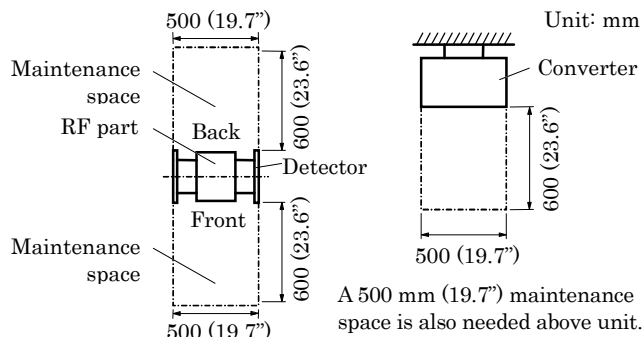

Figure 5. Clearance space

■ Piping Precautions

- (1) **A vertical installation of the LQ500 is recommended. Avoid installing horizontally (install LQ500 vertically) in case of following environments.**
 - a) Places where bubbles or environments air remain in the pipe.
 - b) Places where solids concentration in the fluid is not even because solids in the fluid stay either at the bottom or top of the pipe due to slow fluid velocity or other reason.
 - c) Pipe size is enlarged to install a larger meter sized LQ500.
- (2) **Install the LQ500 in a pipeline where the pipe is always filled with fluid and without bubbles or entrapped air. If these conditions are not satisfied, the measured value varies or may give an inaccurate reading. It is recommended that the LQ500 is installed at the outlet instead of the suction side.**
- (3) **Avoid places where sediment collects at the bottom of the pipe.**
- (4) Avoid places where air gets into the fluid. To avoid this problem, install the LQ500 to the outlet of a pump, not to the suction side.
- (5) When installing the detector horizontally, install it so that the RF-part of it is oriented up (that is, a pair of applicators stay horizontally) to make it easier for maintenance work and to obtain its specified performance.
- (6) The LQ500 can be installed in either direction (upstream or downstream) and without requiring a straight pipe section. Install it in a place allowing easy on-site maintenance.

- (7) Install an adjustable piping mechanism if there is a possibility that the detector pipe may not fit between mating flanges.
- (8) Install the LQ500 in a place where enough water pressure is applied. Therefore, it is recommended that the LQ500 be installed as far away as possible from the pipe outlet opened to atmosphere. This is to prevent the effects of air being trapped in the liquid.
- (9) If there is a possibility of no liquid flow or uneven liquid distribution occurring when a pump is off, use an external synch control signal to operate the LQ500 only when the pump is working.
- (10) Provide a stop valve at upstream and downstream of the detector, and between stop valves and the LQ500 provide the four valves described below with a stop valve attached to each: 1) sampling outlet valve; 2) zero point water inlet valve; 3) vent valve; and 4) drain valve. If it is not possible to stop the fluid at the point where the LQ500 is installed, provide a bypass pipe with a stop valve provided in the middle. These valves are needed to drain the fluid from the detector pipe and fill it with drinking water (density or consistency 0%) to adjust the zero point. See Figures 6 and 7.
- (11) Use gaskets for piping of the size conformed to flange rating and of the material appropriate for the liquid to be measured.

NOTE:

• **Zero point water valve:**

Used to supply drinking water (density or consistency 0%) to the detector pipe for zero point adjustment. Install this valve at the top of the pipe in the case of horizontal installation. It is recommended that a 1-inch ball valve be installed on the top of the pipe and zero point water supplied through this inlet using a vinyl hose etc.

Note: If valve water pipe is connected to this valve, air cannot be extracted. Therefore, another valve (vent valve) is needed to extract air.

• **Vent valve:**

Used to vent process fluids to open air when performing zero adjustment. This helps the drinking water (density or consistency 0%) enter the detector pipe easily. Install this valve on the top of the pipe in the case of horizontal installation.

• **Drain valve:**

Used to drain the fluids before supplying drinking water (density or consistency 0%) to the detector pipe for zero adjustment. Install this valve at the lowest point of the pipe. It is recommended that a 1-inch ball valve be installed at the lowest point of the pipe.

• **Sampling valve:**

Used to extract fluids for manual analysis.

Install this valve to the side of the pipe in the case of horizontal installation. It is recommended that a 1-inch ball valve be installed to the side of the pipe.

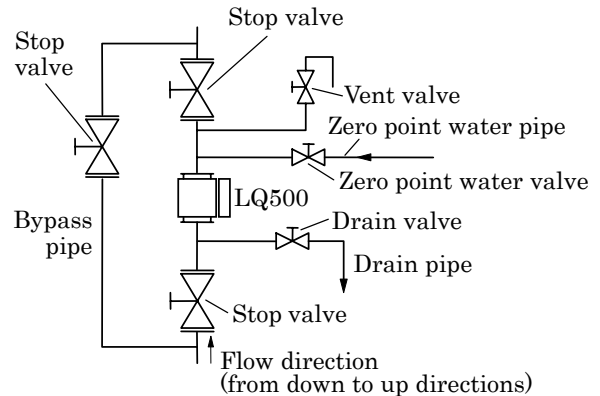

Figure 6. Recommended Installation (vertical installation)

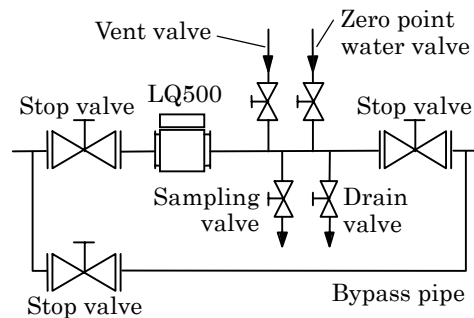
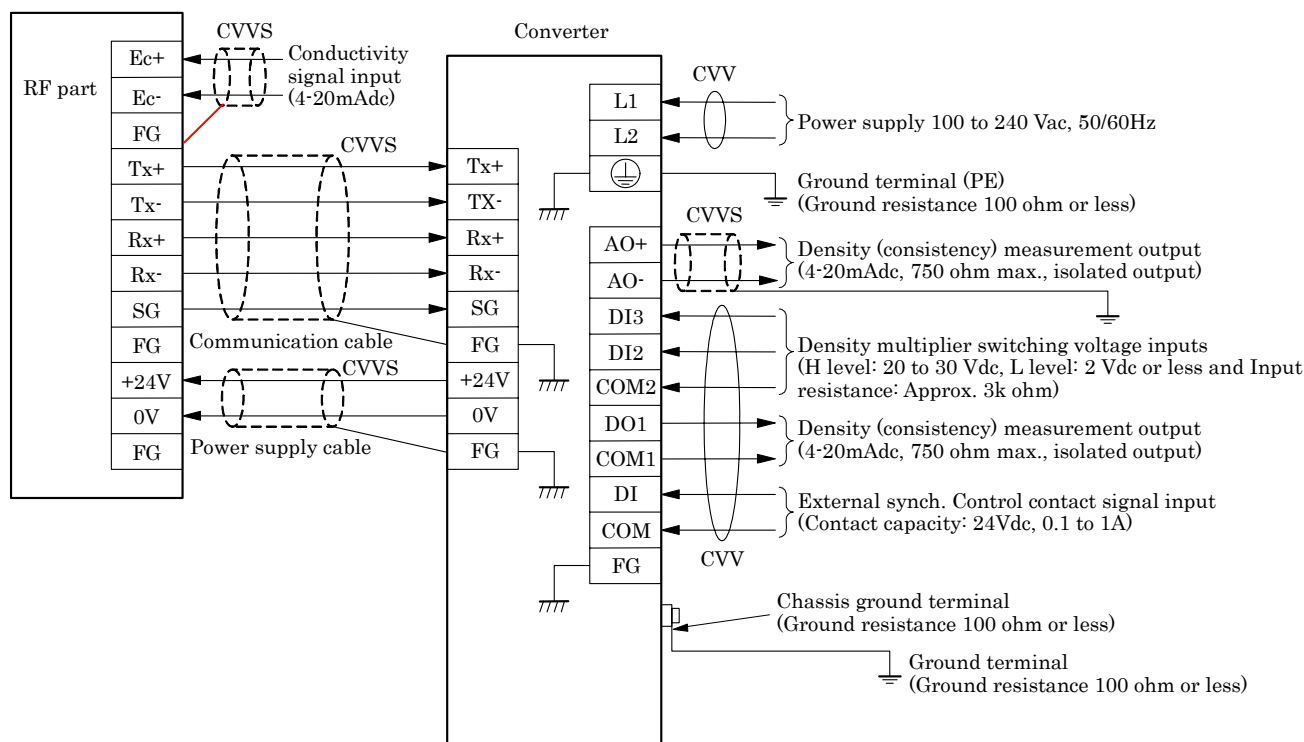

Figure 7. Recommended Installation (horizontal installation)

■ **Wiring Precautions**

- (1) Provide a switch and a fuse to isolate the unit from the mains power for ease of maintenance.
- (2) Ground the LQ500 with 100 ohm or less ground resistance. Do not use a common ground shared by other power equipment.
- (3) Use the accessories cables for communication and power supply between detector and converter. Connect cables to the terminals that match the marking on the cables.
- (4) Use a sheathed cable with 2mm² cross-sectional area for AC power cable.
- (5) The cables should be free from vibration and should have no slack in the cables.
- (6) Wire the LQ500 output in conduit separated from those of AC power cable, control signals, alarm signal or other cables which could become the source of noise.
- (7) Use a 2-wire shielded sheathed cable to wire the LQ500 output (4-20mA dc) and conductivity signal. Ground the shielded cable on the receiving instrument side for both cable.



Notice 1: Do not connect to the “FG” terminals neither communication cable nor power supply cable in the detector side.

Notice 2: Either “PE” terminal on the terminal block in the converter on the chassis ground terminal of the unit should be grounded with 100 ohm or less ground.

Notice 3: Ground the shielded cable on the receiving instrument side.

Notice 4: UL/CUL Hazardous locations type does not have a power switch. Please prepare a power switch outside. (Rated 250V AC, 10A above, DPST: Double-Pole/Single-Throw)

Use the power switch for Hazardous locations in Hazardous locations area.

Figure 8. External connections

- (8) As the cable port is made air-tight using a packing, tighten the cable gland securely when all the wiring is completed. If the diameter of the cable is smaller than the inside diameter of the packing, enlarge the cable diameter to the same size as the packing by wrapping valves around the cable. Its suitable diameter is 11mm. Tighten the terminal screws securely. Its suitable torque is 1.0 to 1.7 N·m.
- (9) Screws at the terminals are needed to tighten with 1.2 N·m torque (1.4 N·m is maximum).
- (10) Do not turn on the power supply under the uninstalled condition.
- (11) Each cable in the communication cable and power supply cable between detector and converter has a banded marks for each terminals. Connect them correctly without any mismatches.

● **Wiring when communications function is used**
By connecting the cable lead of the optional AF900 hand-held terminal to the density (consistency) measurement output, you can operate the LQ500 from remote places.

- 1) Make sure the load resistance of 4-20mA line of output is between 240 and 750 ohm, and the load capacitance is 0.25μF maximum.
- 2) The AF900's cable lead can be connected to

the LQ500 anywhere along the current output line. For example, the cable lead may be connected to the signal terminals on the receiving side in the control room. See Figure 9.

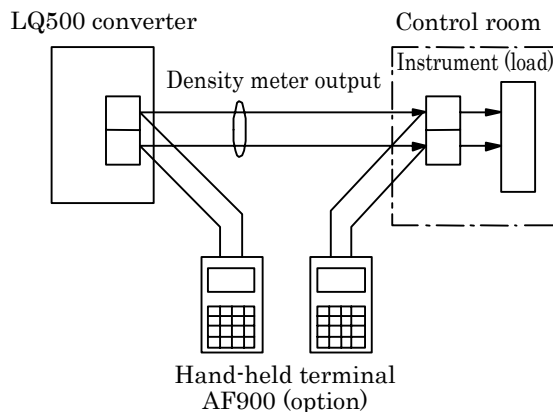

Figure 9. Wiring for communication function

Ordering Information

When ordering the LQ500, refer to Table 4. Type Specification Code. An entry must be made for each of the columns.

The following items must also be specified:

1. Fluid characteristics:
 - Type of material to be measured
 - Density (consistency) (max., normal, min.)
 - Temperature (max., normal, min.)
 - Pressure (max., normal, min.)
 - Conductivity (max., normal)
2. Measurement range
3. Tag number (specify “None” if not needed)
4. Hand-held terminal Required or not
(Refer to Table 5 below.)
5. Other specific items

Table 4. Type Specification Code (LQ500 Density (consistency) Meter)

TYPE					CAT Code									SPECIFICATION
1	2	3	4	5	6	7	8	9	10	11	12	13	14	
L	Q	5	0	0										Microwave Density (Consistency) Meter
					A									Standard
						0	5							Meter Size 50mm (2")
						0	8							80mm (3")
						1	0							100mm (4")
						1	5							150mm (6")
						2	0							200mm (8")
						2	5							250mm (10")
						3	0							300mm (12")
														Mounting Style
					B									JIS 10K flange connection
					C									ANSI 150 flange connection
					F									DIN 16 flange connection
														Purpose
					A									Standard
					B									for PED (150 to 300 mm (6" to 12") for EU) (Note 1)
					C									for UL/CUL Hazardous locations type
														Wetting parts
					A									SCS14A cast (Equivalent to 316L SS) pipe (standard)
					B									SCS14A cast (Equivalent to 316L SS) pipe with teflon PFA coating for sticky application
					C									SCS14A cast (Equivalent to 316L SS) pipe for abrasive application (Note 2)
					D									Hastelloy C pipe
														Cable length between detector (RF part) & converter
					A									10 m (32.8 ft) (standard)
					B									20 m (65.6 ft)
					C									30 m (98.4 ft)
					D									40 m (131.2 ft)
					E									50 m (164 ft)
					X									None (Note 3)
														Optional specifications
					A									None (standard) (blank codes are required.)
					B									Pipe buffing type
					A									-20 to 50 deg.C (-4 to 122 deg.F) environment temperature specification, 200 to 240 Vac power supply type of LQ500
					D									Pipe buffing type with -20 to 50 deg.C (-4 to 122 deg.F) environment temperature specification, 200 to 240 Vac power supply type of LQ500
					E									-20 to 50 deg.C (-4 to 122 deg.F) environment temperature specification, 100 to 120 Vac power supply type of LQ500
					F									Pipe buffing type with -20 to 50deg.C (-4 to 122deg.F) environment temperature specification, 100 to 120 Vac power supply type of LQ500

Note 1: The specification of PED (Pressure Equipment Directive) is required from 150 to 300 mm (6" to 12") when the installation location is in the Europe.

Note 2: The differences between standard type are RTD sensor and Applicator window.

Note 3: Toshiba recommends to using our specified cable. ISO9001 and ISO14001 are certified.

Table 5. Type Specification Code (AF900 Hand-held Terminal)

Model					Specification Code							Description	
1	2	3	4	5	6	7	8	9	10	11	12		
A	F	9	0	0									Hand-held terminal
					L	Q	3						For use with LQ series
								A					Display language English
									A	A	3		Standard

Table 6. PED matrix

Flange	Meter Size							
	mm	50	80	100	150	200	250	300
	inch	2	3	4	6	8	10	12
DIN16	SEP				Certified			
DIN10	SEP						Certified	
ANSI150	SEP				Certified			

SEP: Not required the PED.

Certified: The PED is certified.

Check your flange type and its meter size of the LQ500 whether it corresponds to the PED or not when its installing location is in the Europe.

If yes, you need to choose the code "B" at the 10th column in the specification code (Table 4)



Misuse of this product can result in damages to property or human injury. Read related manuals carefully before using this product.

Specifications are subject to change without notice.

Printed in Japan 2006-11 (TDOC)

© TOSHIBA Corporation 2003

All Rights Reserved.