

# PCG-GRT99/GRT77/GRT55/GRT170/GRT150/GRT25F/GRT160/ PCG-GRT716S/GRT796HP/GRT715E/GRT795MP/GRT715M/GRT796SP/GRT786M/ PCG-GRT785B/GRT785E/GRT30P/GRT25/GRT30LP/GRT30CP/GRT25CP/GRT25L

## SERVICE MANUAL

Ver 4-2003H

### Revision History

Area	Model	Line up
Japanese	Japanese	PCG-GRT99/P PCG-GRT77/B PCG-GRT55/B
American	US Canadian	PCG-GRT170 PCG-GRT150 PCG-GRT160 [MA]
	Latin	PCG-GRT25F [MA]
European	AEP UK	PCG-GRT716S [MA]
		PCG-GRT796HP [MA]
		PCG-GRT715E [MA]
		PCG-GRT795MP [MA]
		PCG-GRT715M [MA]
		PCG-GRT796SP [MA]
		PCG-GRT785B [MA]
PCG-GRT785E [MA]		
PCG-GRT786M [MA]		
Asian/Oceania/ South Africa	International	PCG-GRT30P [MA]
		PCG-GRT25 [MA]
	Korean	PCG-GRT30LP [MA]
		PCG-GRT25L [MA]
	Chinese	PCG-GRT30CP [MA]
		PCG-GRT25CP [MA]

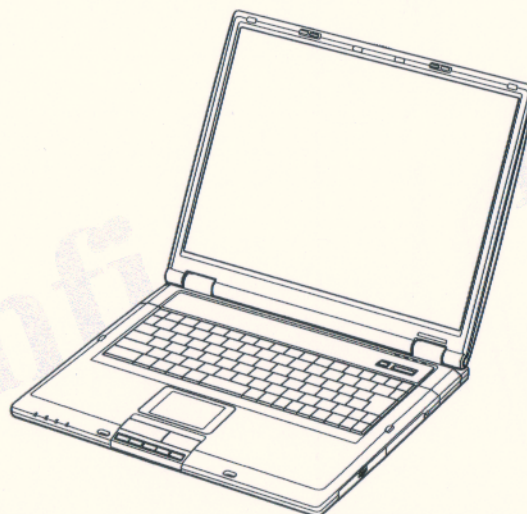

Illust : PCG-GRT99/P



S400



MEMORY STICK™



- 本機の仕様および外観は、改良のため予告なく変更することがありますが、ご了承ください。
- Design and specifications are subject to change without notice.

## NOTEBOOK COMPUTER

# SONY®

Information in this document is subject to change without notice.

Sony, VAIO and CLIE are trademarks or registered trademarks of Sony. Microsoft, Windows, Windows Media, Outlook, Bookshelf and other Microsoft products are trademarks or registered trademarks of Microsoft Corporation in the United States and other countries.

The word Bluetooth and the Bluetooth logo are trademarks of Bluetooth SIG, Inc. AMD, AMD logo, AMD Duron and combinations thereof, 3DNow!, are trademarks of Advanced Micro Devices, Inc. Intel Inside logo, Pentium and Celeron are trademarks or registered trademarks of Intel Corporation. Transmeta, the Transmeta logo, Crusoe Processor, the Crusoe logo and combinations thereof are trademarks of Transmeta Corporation in the USA and other countries. Graffiti, HotSync, PalmModem, and Palm OS are registered trademarks, and the Hotsync logo and Palm are trademarks of Palm, Inc. or its subsidiaries. (M) and Motrola are trademarks of Motrola, Inc. Other Motrola products and services with (R) mark like Dragomball are the trademarks of Motrola, Inc.

All other names of systems, products and services in this manual are trademarks or registered trademarks of their respective owners. In this manual, the (TM) or (R) mark are not specified.

Caution Markings for Lithium/Ion Battery - The following or similar texts shall be provided on battery pack of equipment or in both the operating and the service instructions.

CAUTION: Danger of explosion if battery is incorrectly replaced. Replace only with the same or equivalent type recommended by the manufacturer. Discard used batteries according to the manufacturer's instructions.

CAUTION: The battery pack used in this device may present a fire or chemical burn hazard if mistreated. Do not disassemble, heat above 100°C (212°F) or incinerate. Dispose of used battery promptly. Keep away from children.

CAUTION: Changing the back up battery.

- Overcharging, short circuiting, reverse charging, mutilation or incineration of the cells must be avoided to prevent one or more of the following occurrences; release of toxic materials, release of hydrogen and/or oxygen gas, rise in surface temperature.
- If a cell has leaked or vented, it should be replaced immediately while avoiding to touch it without any protection.

## Service and Inspection Precautions

### 1. Obey precautionary markings and instructions

Labels and stamps on the cabinet, chassis, and components identify areas requiring special precautions. Be sure to observe these precautions, as well as all precautions listed in the operating manual and other associated documents.

### 2. Use designated parts only

The set's components possess important safety characteristics, such as noncombustibility and the ability to tolerate large voltages. Be sure that replacement parts possess the same safety characteristics as the originals. Also remember that the  $\Delta$  mark, which appears in circuit diagrams and parts lists, denotes components that have particularly important safety functions; be extra sure to use only the designated components.

### 3. Always follow the original design when mounting parts and routing wires

The original layout includes various safety features, such as inclusion of insulating materials (tubes and tape) and the mounting of parts above the printer board. In addition, internal wiring has been routed and clamped so as to keep it away from hot or high-voltage parts. When mounting parts or routing wires, therefore, be sure to duplicate the original layout.

### 4. Inspect after completing service

After servicing, inspect to make sure that all

screws, components, and wiring have been returned to their original condition. Also check the area around the repair location to ensure that repair work has caused no damage, and confirm safety.

### 5. When replacing chip components...

Never reuse components. Also remember that the negative side of tantalum capacitors is easily damaged by heat.

### 6. When handling flexible print boards...

- The temperature of the soldering-iron tip should be about 270C.
- Do not apply the tip more than three times to the same pattern.
- Handle patterns with care; never apply force.

Caution: Remember that hard disk drives are easily damaged by vibration. Always handle with care.

### ATTENTION AU COMPOSANT AYANT RAPPORT À LA SÉCURITÉ!

LES COMPOSANTS IDENTIFIÉS PAR UNE MARQUE  $\Delta$  SUR LES DIAGRAMMES SCHÉMATIQUES ET LA LISTE DES PIÈCES SONT CRITIQUES POUR LA SÉCURITÉ DE FONCTIONNEMENT. NE REMPLACER CES COMPOSANTS QUE PAR DES PIÈCES SONY DONT LES NUMÉROS SONT DONNÉS DANS CE MANUEL OU DANS LES SUPPLÉMENTS PUBLIÉS PAR SONY.

**Confidential**

PCG-GRT99/GRT77/GRT55 (J)  
PCG-GRT170/GRT150/GRT25F/GRT160 (AM)  
PCG-GRT716S/GRT796HP/GRT715E/GRT795MP/GRT715M/  
PCG-GRT796SP/GRT786M/GRT785B/GRT785E (EU)  
PCG-GRT30P/GRT25/GRT30LP/GRT30CP/GRT25CP/GRT25L (AO)

## TABLE OF CONTENTS

<u>Section</u>	<u>Title</u>	<u>Page</u>	<u>Section</u>	<u>Title</u>	<u>Page</u>
<b>CHAPTER 1. SPECIFICATIONS</b>		1-1	Accessory		
		(to 1-2)	A-1		4-31
<b>CHAPTER 2. BLOCK DIAGRAM</b>		2-1	DIP Switch		4-33
		(to 2-2)			(to 4-34)
<b>CHAPTER 3. FRAME HARNESS DIAGRAM</b>		3-1	<b>CHAPTER 5. OTHERS</b>		
		(to 3-2)	5-1. The Barcode Label		5-1
<b>CHAPTER 4. EXPLODED VIEWS AND PARTS LIST</b>			5-2. Replacing the CPU		5-3
Optical Drive			1. Removing the CPU		5-3
D-1		4-3	2. Installing the CPU		5-3
Palmrest			5-3. CTO Information		5-4
P-1. Palmrest (16-inch Model)		4-5	1. PCG-GRT770		5-4
P-2. Palmrest (15-inch Model)		4-7	2. PCG-GRT750		5-6
Bottom			3. PCG-GRT100		5-8
B-1. Bottom (16-inch Model)		4-9			(to 5-9)
B-2. Bottom (15-inch Model)		4-11			
Main Board					
M-1		4-13			
Hood Keyboard					
H-1		4-15			
Other Parts					
O-1		4-17			
LCD					
L-1. (16-inch SXGA – Made by SH –)		4-19			
L-2. (16-inch UXGA, SXGA (Clear Black LCD)					
– Made by HI –)		4-21			
L-3. (16-inch UXGA, SXGA (Normal) – Made by HI –)		4-23			
L-4. (15-inch XGA (Clear Black) – Made by HI –)		4-25			
L-5. (15-inch SXGA, XGA (Normal, High Brightness)					
– Made by SH –)		4-27			
L-6. (14-inch XGA – Made by HI –)		4-29			

変更履歴は、"Revision History"として、  
本データ末に記載してあります。

History of the changes is shown as the  
"Revision History" at the end of this data.

**Confidential**

PCG-GRT99/GRT77/GRT55 (J)  
PCG-GRT170/GRT150/GRT25F/GRT160 (AM)  
PCG-GRT716S/GRT796HP/GRT715E/GRT795MP/GRT715M/  
PCG-GRT796SP/GRT786M/GRT785B/GRT785E (EU)  
PCG-GRT30P/GRT25/GRT30LP/GRT30CP/GRT25CP/GRT25L (AO)

# CHAPTER 1. SPECIFICATIONS

	J			AM				EU			
	PCG-GRT99/P	PCG-GRT77/B	PCG-GRT55/B	PCG-GRT170	PCG-GRT150	PCG-GRT25F	PCG-GRT160	PCG-GRT716S	PCG-GRT796HP	PCG-GRT715E	PCG-GRT795MP
CPU	P4-2.80GHz	P4-2.66GHz	M-Cel 1.80GHz	P4-2.80GHz	P4-2.80GHz	P4 2.66GHz	P4-2.66GHz	P4 2.80GHz	P4-2.80GHz	P4-2.66GHz	P4-2.66GHz
LCD	16.1UXGA (Clear Black)	16.1SXGA+ (Clear Black)	15XGA (Clear Black)	16.1SXGA+	16SXGA	15XGA	15XGA (Clear Black)	16.1SXGA+ (Clear Black)	16SXGA+	15XGA (High Brightness)	15XGA
HDD	80GB	60GB	60GB	60GB	60GB	40GB	60GB	60GB	60GB	40GB	40GB
Graphics	GeForce FX Go5600	GeForce4 420Go	GeForce4 420Go	GeForce FX Go5600	GeForce4 420Go	GeForce4 420Go	GeForce4 420 Go	GeForce FX Go5600	GeForce4 420Go	GeForce4 420Go	GeForce4 420Go
DDR MEMORY1	512MB X 1	256MB X 2	256MB X 1	256MB X 2	256MB X 2	256MB X 2	256MB X 2	256MB X 2	256MB X 2	256MB X 1	256MB X 1
QUANTITY [STANDARD/MAX]	512/1024	512/1024	256/1024	512/1024	512/1024	512/1024	512/1024	512/1024	512/1024	256/1024	256/1024
OPT-DRIVE	DVD+-RW	DVD+-RW	DVD-RW	DVD+-RW	CD-RW/ DVD-ROM	DVD-RW	DVD+-RW	DVD+-RW	CD-RW/ DVD-ROM	DVD+-RW	CD-RW/ DVD-ROM
TV tuner	○	○	○	X	X	X	X	X	X	X	X
int. Wireless LAN	X	X	X	X	○	X	○	X	X	○	○
AC adaptor	PCGA-AC19V6	PCGA-AC19V6	PCGA-AC19V6	PCGA-AC19V7	PCGA-AC19V7	PCGA-AC19V7	PCGA-AC19V7	PCGA-AC19V7	PCGA-AC19V7	PCGA-AC19V7	PCGA-AC19V7
Battery	PCGA-BP2NX	PCGA-BP2NX	PCGA-BP2NX	PCGA-BP2NX	PCGA-BP2NX	PCGA-BP2NX	PCGA-BP2NX	PCGA-BP2NX	PCGA-BP2NX	PCGA-BP2NX	PCGA-BP2NX
OS	WinXP Pro	WinXP Pro	WinXP Pro	WinXP Home	WinXP Home	WinXP Home	WinXP Home	WinXP Home	WinXP Home	WinXP Home	WinXP Pro

△ [MA]

△ [MA]

	EU					AO					
	PCG-GRT715M	PCG-GRT796SP	PCG-GRT786M	PCG-GRT785B	PCG-GRT785E	PCG-GRT30P	PCG-GRT25	PCG-GRT30LP	PCG-GRT30CP	PCG-GRT25CP	PCG-GRT25L
CPU	P4-2.80GHz	P4 M2.5GHz	P4-2.66GHz	P4-2.66GHz	P4-2.66GHz	P4 2.80GHz	P4 2.40BGHz	P4-2.80GHz	P4-2.80GHz	P4-2.40BGHz	P4-2.40BGHz
LCD	15XGA (High Brightness)	16.1UXGA	16.1SXGA+ (Clear Black)	15SXGA+	15XGA (High Brightness)	16.1UXGA	15XGA	16.1UXGA	16.1UXGA	15XGA	15XGA
HDD	40GB	80GB	40GB	60GB	40GB	60GB	40GB	60GB	60GB	40GB	40GB
Graphics	GeForce FX Go5600	GeForce FX Go5600	GeForce FX Go5600	GeForce4 420Go	GeForce FX Go5600	GeForce FX Go5600	GeForce4 420Go	GeForce FX Go5600	GeForce FX Go5600	GeForce4 420Go	GeForce4 420Go
DDR MEMORY1	256MB X 2	512MB X 2	256MB X 2	256MB X 2	256MB X 2	512MB X 1	256MB X 1	512MB X 1	512MB X 1	256MB X 1	256MB X 1
QUANTITY [STANDARD/MAX]	512/1024	1024/1024	512/1024	512/1024	512/1024	512/1024	256/1024	512/1024	512/1024	256/1024	256/1024
OPT-DRIVE	DVD+-RW	DVD+-RW	DVD-RW	CD-RW/ DVD-ROM	DVD+-RW	DVD+-RW	DVD-RW	DVD+-RW	DVD+-RW	DVD-RW	DVD-RW
TV tuner	X	X	X	X	X	X	X	X	X	X	X
int. Wireless LAN	X	○	X	X	X	○	X	○	○	X	X
AC adaptor	PCGA-AC19V7	PCGA-AC19V7	PCGA-AC19V7	PCGA-AC19V7	PCGA-AC19V7	PCGA-AC19V7	PCGA-AC19V7	PCGA-AC19V7	PCGA-AC19V7	PCGA-AC19V7	PCGA-AC19V7
Battery	PCGA-BP2NX	PCGA-BP2NX	PCGA-BP2NX	PCGA-BP2NX	PCGA-BP2NX	PCGA-BP2NX	PCGA-BP2NX	PCGA-BP2NX	PCGA-BP2NX	PCGA-BP2NX	PCGA-BP2NX
OS	WinXP Pro	WinXP Pro	WinXP Home	WinXP Home	WinXP Home	WinXP Pro	WinXP Home	WinXP Pro	WinXP Home	WinXP Home	WinXP Home

△ [MA]

△ [MA]

△ [MA]

△ [MA]

△ [MA]

△ [MA]

• 本表中の商標・登録商標については、2ページをご参照ください。

• The trademarks or registered trademarks of above table, refer to page 2.

**Confidential**

PCG-GRT99/GRT77/GRT55 (J)  
PCG-GRT170/GRT150/GRT25F/GRT160 (AM)  
PCG-GRT716S/GRT796HP/GRT715E/GRT795MP/GRT715M/  
PCG-GRT796SP/GRT786M/GRT785B/GRT785E (EU)  
PCG-GRT30P/GRT25/GRT30LP/GRT30CP/GRT25CP/GRT25L (AO)

# CHAPTER 2. BLOCK DIAGRAM

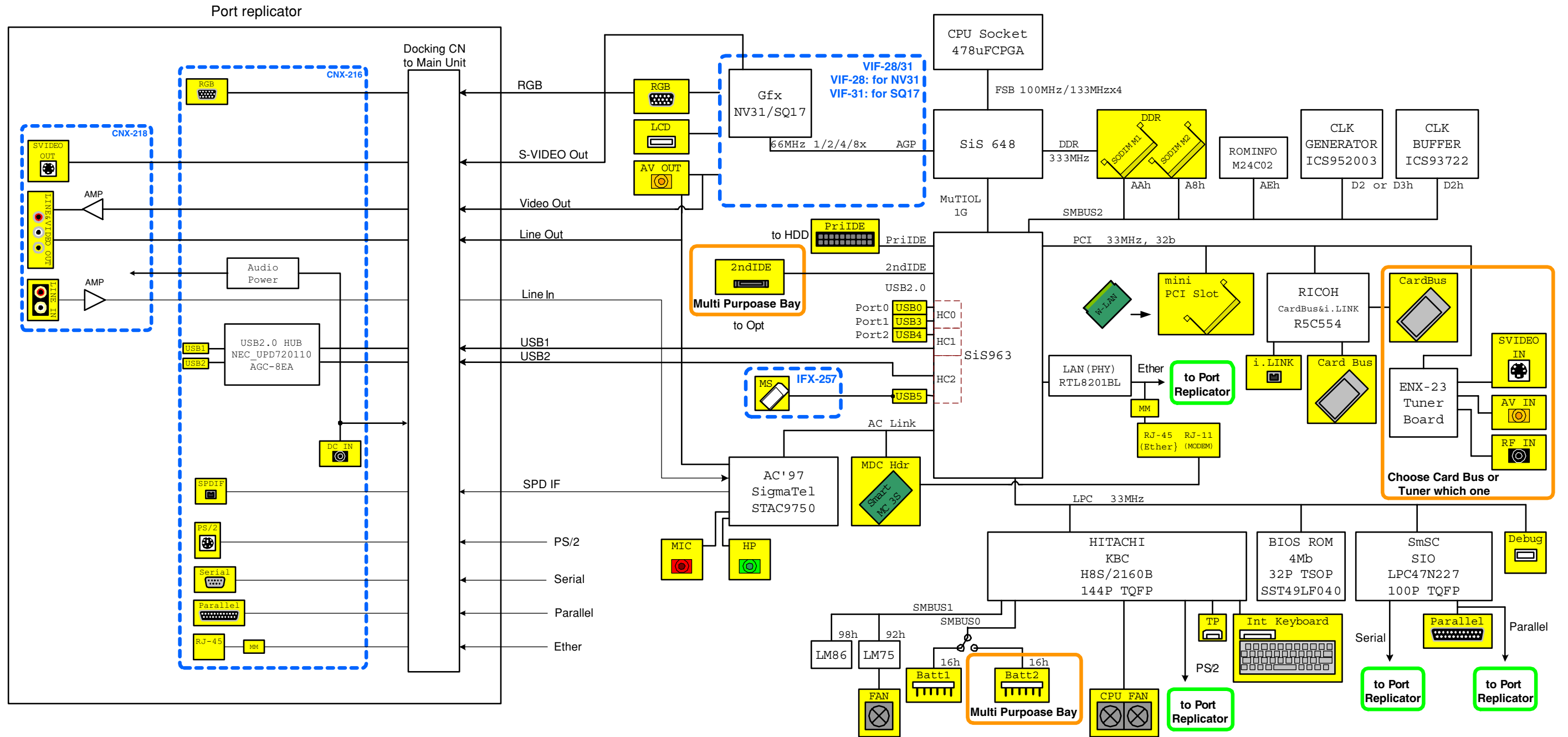

# CHAPTER 3. FRAME HARNESS DIAGRAM

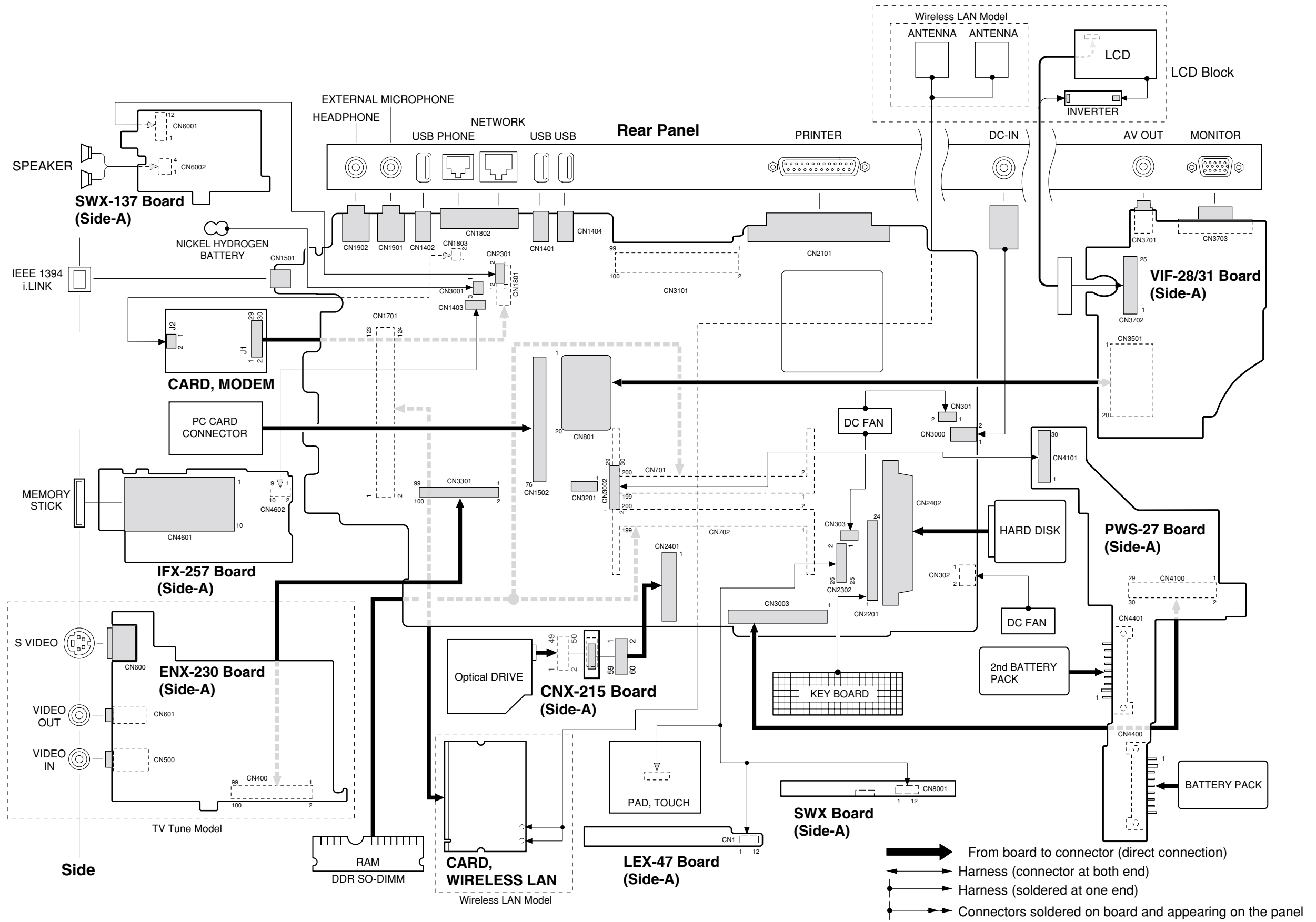

- From board to connector (direct connection)
- Harness (connector at both end)
- Harness (soldered at one end)
- Connectors soldered on board and appearing on the panel

**Confidential**

PCG-GRT99/GRT77/GRT55 (J)  
 PCG-GRT170/GRT150/GRT25F/GRT160 (AM)  
 PCG-GRT716S/GRT796HP/GRT715E/GRT795MP/GRT715M/  
 PCG-GRT796SP/GRT786M/GRT785B/GRT785E (EU)  
 PCG-GRT30P/GRT25/GRT30LP/GRT30CP/GRT25CP/GRT25L (AO)

# CHAPTER 4.

## EXPLODED VIEWS AND PARTS LIST

• The parts list is compiled by blocks of a palmrest and bottom etc. The sections of the parts list are different depending on the model. Please refer to list of contents shown in the below.

• 分解図と部品表は、パームレスト、ボトムなどのブロックごとに分かれています。機種によって部品表のセクションが異なりますので、詳細は右下の一覧表を参照してください。

Section	Page
<b>Optical Drive</b>	
D-1	4-3
<b>Palmrest</b>	
P-1 (16-inch Model)	4-5
P-2 (15-inch Model)	4-7
<b>Bottom</b>	
B-1 (16-inch Model)	4-9
B-2 (15-inch Model)	4-11
<b>Main Board</b>	
M-1	4-13
<b>Hood Keyboard</b>	
H-1	4-15
<b>Other Parts</b>	
O-1	4-17
<b>LCD</b>	
L-1 (16-inch SXGA – Made by SH –)	4-19
L-2 (16-inch UXGA, SXGA (Clear Black) – Made by HI –)	4-21
L-3 (16-inch UXGA, SXGA (Normal) – Made by HI –)	4-23
L-4 (15-inch XGA (Clear Black) – Made by HI –)	4-25
L-5 (15-inch SXGA, XGA (Normal, High Brightness) – Made by SH –)	4-27
L-6 (14-inch XGA – Made by HI –)	4-29
<b>Accessory</b>	
A-1	4-31
<b>DIP Switch</b>	4-33

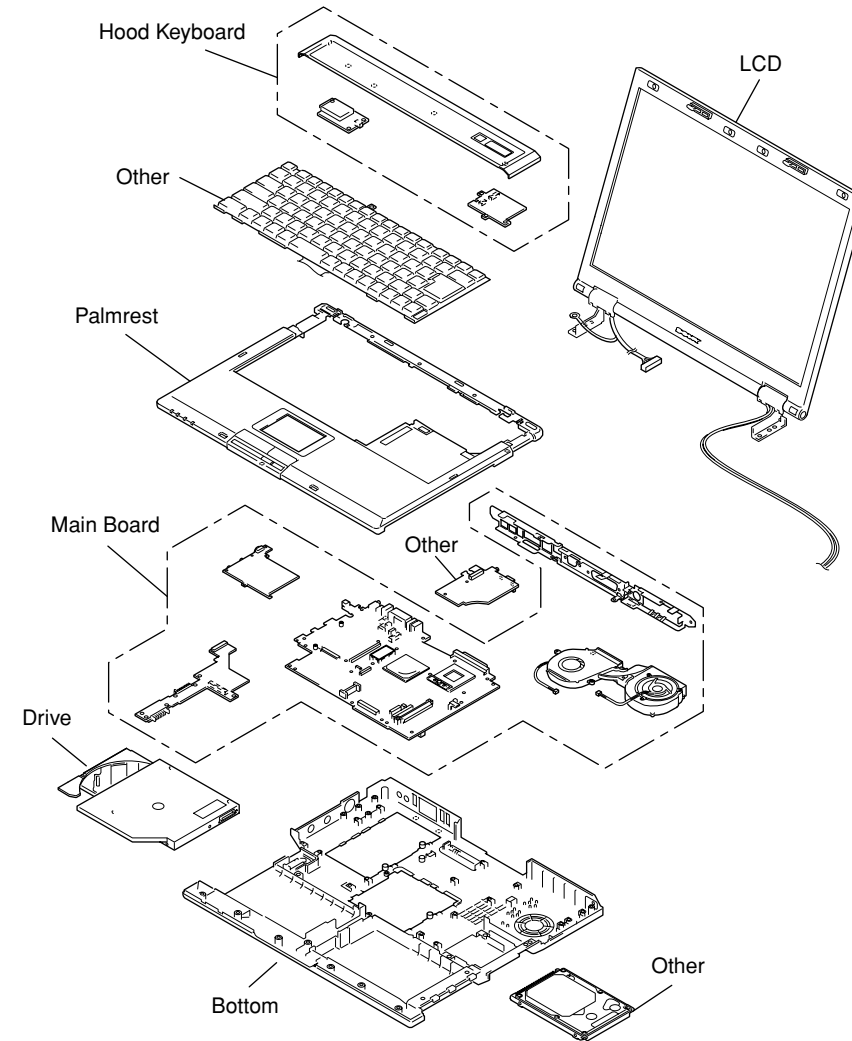

### NOTE:

- Items marked “\*” are not stocked since they are seldom required for routine service. Some delay should be anticipated when ordering these items.
- The mechanical parts with no reference number in the exploded views are not supplied.
- When two or more parts are shown, use the part described first as the main part.
- The parts marked “\$” are the High Value Modules (HVM).
- The parts marked “#” are the parts on which barcode label is attached. For the barcode label, refer to CHAPTER 5.
- The parts marked “&” are the “Customer Replacable Parts (CRP)” that can be replaced by Field Customer Support. Especially the parts with the <&> mark require the special attention to use them. Here fore, check first whether the desired part is one of the targetted parts of the Customer Replacable Parts(CRP), or the non-targetted parts by referring to the exploded view.
- The indication [CH] is used for identification of part type.
- Regarding the boards of this model, the discrete parts on the boards cannot be replaced. However, Some connectors can be replaced.

### 【使用上の注意】

- \*印の部品は常備在庫しておりません。
- 図面番号のない部品は供給しません。
- 併記部品の場合、上部記載部品をメイン部品として使用してください。
- 部品名称の前に\$印のついた部品は、High Value Module (HVM) です。
- 部品名称の前に#印のついた部品は、バーコードラベル貼付部品です。バーコードラベルについてはCHAPTER 5を参照してください。
- 部品名称の前に&印のついた部品は、お客様窓口などでも交換可能な Customer Replacable Parts (CRP)です。特に<&>印のついた部品は、使い分けが必要な部品ですので、分解図で Customer Replacable Parts 対象部品か、対象外部部品かを必ず御確認ください。
- [CH]の表記は部品管理上の識別です。
- 本モデルの基板については、基板上の各部品の修理は行うことができません。ただし、一部のコネクタについては、修理可能です。

The components identified by mark  $\Delta$  or dotted line with mark  $\Delta$  are critical for safety. Replace only with part number specified.

Les composants identifiés par une marque  $\Delta$  sont critiques pour la sécurité. Ne les remplacer que par une pièce portant le numéro spécifié.

$\Delta$ 印の部品、または $\Delta$ 印付きの点線で囲まれた部品は、安全性を維持するために重要な部品です。従って交換時は、必ず指定の部品を使用してください。

		Drive	LCD	Palmrest	Bottom	Main Board	Hood Keyboard	Other	Accessory
J	GRT99/P	D-1	L-2	P-1	B-1	M-1	H-1	O-1	A-1
	GRT77/B	D-1	L-2	P-1	B-1	M-1	H-1	O-1	A-1
	GRT55/B	D-1	L-4	P-2	B-2	M-1	H-1	O-1	A-1
	J-CTO	D-1	L-2,3,4,5	P-1,2	B-1,2	M-1	H-1	O-1	A-1
AM	GRT170	D-1	L-3	P-1	B-1	M-1	H-1	O-1	A-1
	GRT150	D-1	L-1	P-1	B-1	M-1	H-1	O-1	A-1
	U-CTO	D-1	L-1,2,3,4,5,6	P-1,2	B-1,2	M-1	H-1	O-1	A-1
	GRT25F	D-1	L-5	P-2	B-2	M-1	H-1	O-1	A-1
EU	GRT160G	D-1	L-4	P-2	B-2	M-1	H-1	O-1	A-1
	GRT716S	D-1	L-2	P-1	B-1	M-1	H-1	O-1	A-1
	GRT796HP	D-1	L-3	P-1	B-1	M-1	H-1	O-1	A-1
	GRT715E	D-1	L-5	P-2	B-2	M-1	H-1	O-1	A-1
	GRT795MP	D-1	L-5	P-2	B-2	M-1	H-1	O-1	A-1
	GRT715M	D-1	L-5	P-2	B-2	M-1	H-1	O-1	A-1
	GRT796SP	D-1	L-3	P-1	B-1	M-1	H-1	O-1	A-1
	GRT786M	D-1	L-2	P-1	B-1	M-1	H-1	O-1	A-1
	GRT785B	D-1	L-5	P-2	B-2	M-1	H-1	O-1	A-1
	GRT785E	D-1	L-5	P-2	B-2	M-1	H-1	O-1	A-1
AO	GRT30P	D-1	L-3	P-1	B-1	M-1	H-1	O-1	A-1
	GRT25	D-1	L-5	P-2	B-2	M-1	H-1	O-1	A-1
	GRT30LP	D-1	L-3	P-1	B-1	M-1	H-1	O-1	A-1
	GRT30CP	D-1	L-3	P-1	B-1	M-1	H-1	O-1	A-1
	GRT25CP	D-1	L-5	P-2	B-2	M-1	H-1	O-1	A-1
GRT25L	D-1	L-5	P-2	B-2	M-1	H-1	O-1	A-1	

$\Delta$  [MA]  
 $\Delta$  [MA]  
 $\Delta$  [MA]

**Confidential**

PCG-GRT99/GRT77/GRT55 (J)  
 PCG-GRT170/GRT150/GRT25F/GRT160 (AM)  
 PCG-GRT716S/GRT796HP/GRT715E/  
 PCG-GRT795MP/GRT715M/GRT796SP (EU)  
 PCG-GRT30P/GRT25/GRT30LP/GRT30CP/GRT25CP (AO)

**How to Use Parts Differently.**

This series of product uses the three different types of optical drive (To type, Pa type and So type).  
 When replacing the optical drive, use the To type parts for the To type optical drive, and use the Pa type parts for the Pa type optical drive, and use the So type parts for the So type optical drive.  
 Replace the peripheral parts of optical drive with the same type in the same way.

[ How to identify the To, Pa and So types of parts ]

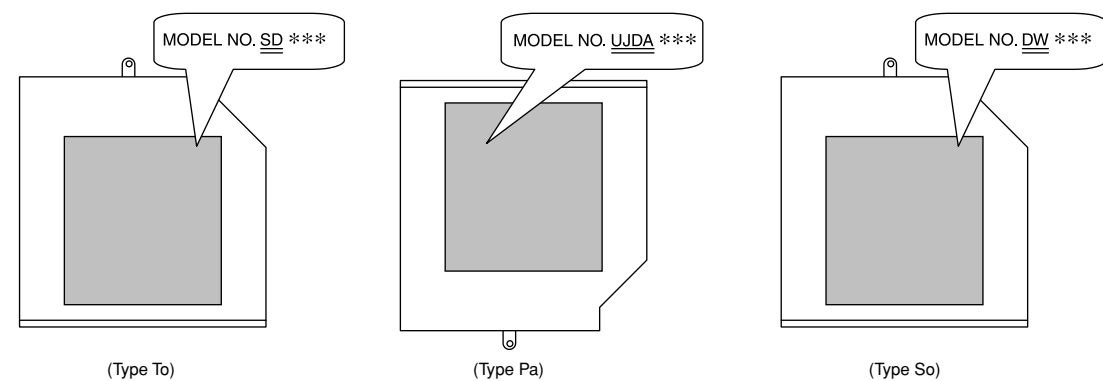

**D-1. Optical Drive**

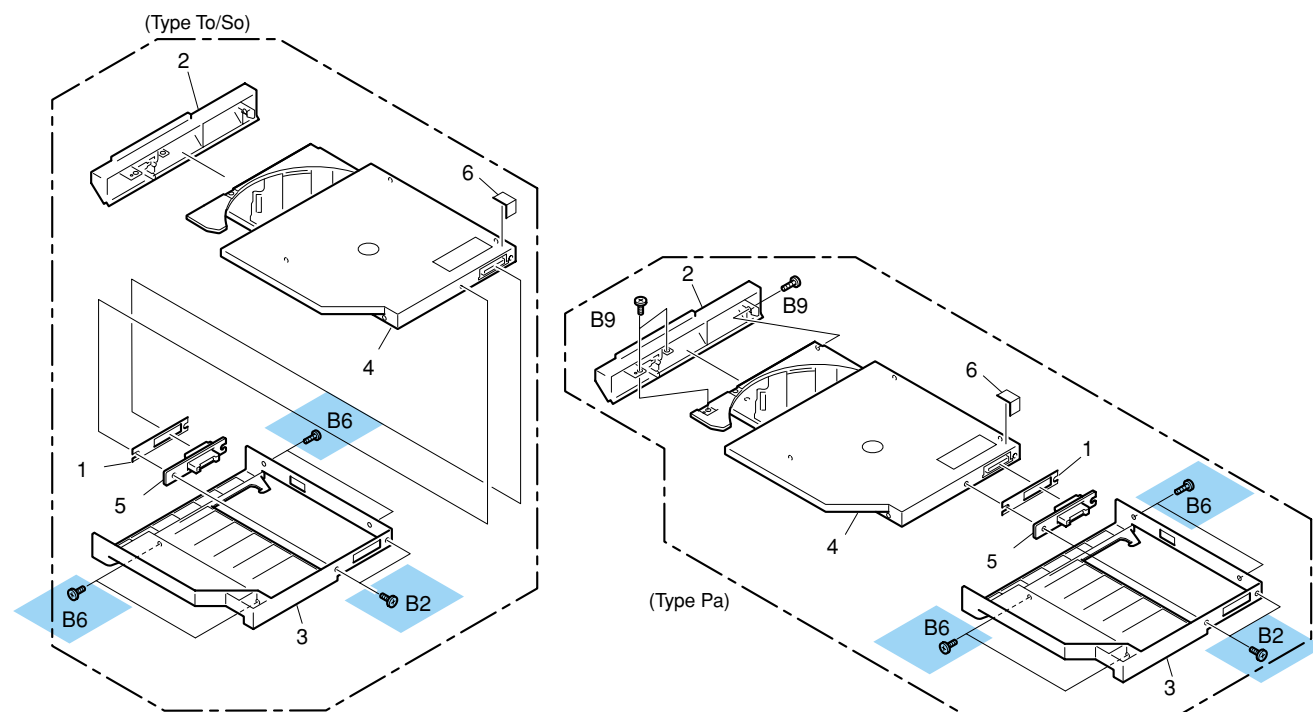

Ref.No.	Part No.	Description
1	4-654-837-01	SHEET BAY BOARD
3	X-4625-949-1	ASSY BAY CASE
5	A-8067-975-A	COMPLETE PWB CNX-215
6	4-677-675-01	ODD CU FOIL
B2	4-669-867-01	& SCREW (M2X4), SPECIAL HEAD
B6	4-656-703-01	& SCREW M2

Ref.No.	Part No.	Description	Model Compatibility																									
			GRT99/P	GRT77/B	GRT55/B	GRT770 *	GRT750 *	GRT170	GRT150	GRT100 *	GRT25F	GRT160	GRT716S	GRT796HP	GRT715E	GRT795MP	GRT715M	GRT796SP	GRT786M	GRT785B	GRT785E	GRT30P	GRT25	GRT30LP	GRT30CP	GRT25CP	GRT25L	
2	X-4625-936-1	ASSY SO DVD+-RW BEZEL	•	•	•	•	•	•	•	•	•	•	•	•	•	•	•	•	•	•	•	•	•	•	•	•	•	•
	X-4625-922-1	DVDRW BEZEL(To)			•																							
	X-4625-937-1	ASSY KME DVD-RW BEZEL(Pa)			•																							
	X-4625-920-1	ASSY KME COMBO BEZEL(Pa)			•																							
4	8-457-509-00	DVD DRIVE, DW-U50A-VN(So)	•	•	•	•	•	•	•	•	•	•	•	•	•	•	•	•	•	•	•	•	•	•	•	•	•	•
	1-796-506-11	W-DVD(SD-R6012)(To)			•																							
	1-796-480-11	W-DVD(UJ-810B)(Pa)			•																							
	1-796-594-11	COMBO DRIVE (UJDA740)(Pa)			•																							
B9	4-645-177-01	SCREW (M1.7X3.5)(Pa)			•																							

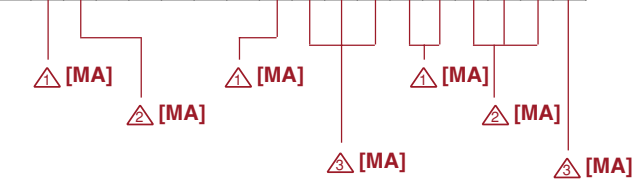

- This parts list contains two different types of parts.  
 The first type is the parts that are common to all models.  
 The other type is the parts that are different depending on each model.
- The model that is accompanied by asterisk (\*) is the CTO model.

• この部品表は、機種共通の部品と、機種によって使い分けが必要な部品に分かれています。  
 • 機種名に(\*)がつくのはCTOモデルです。

**Confidential**

PCG-GRT99/GRT77/GRT55 (J)  
 PCG-GRT170/GRT150/GRT25F/GRT160 (AM)  
 PCG-GRT716S/GRT796HP/GRT715E/  
 PCG-GRT795MP/GRT715M/GRT796SP (EU)  
 PCG-GRT30P/GRT25/GRT30LP/GRT30CP/GRT25CP (AO)



# Palmrest

## P-1. Palmrest (16-inch Model)

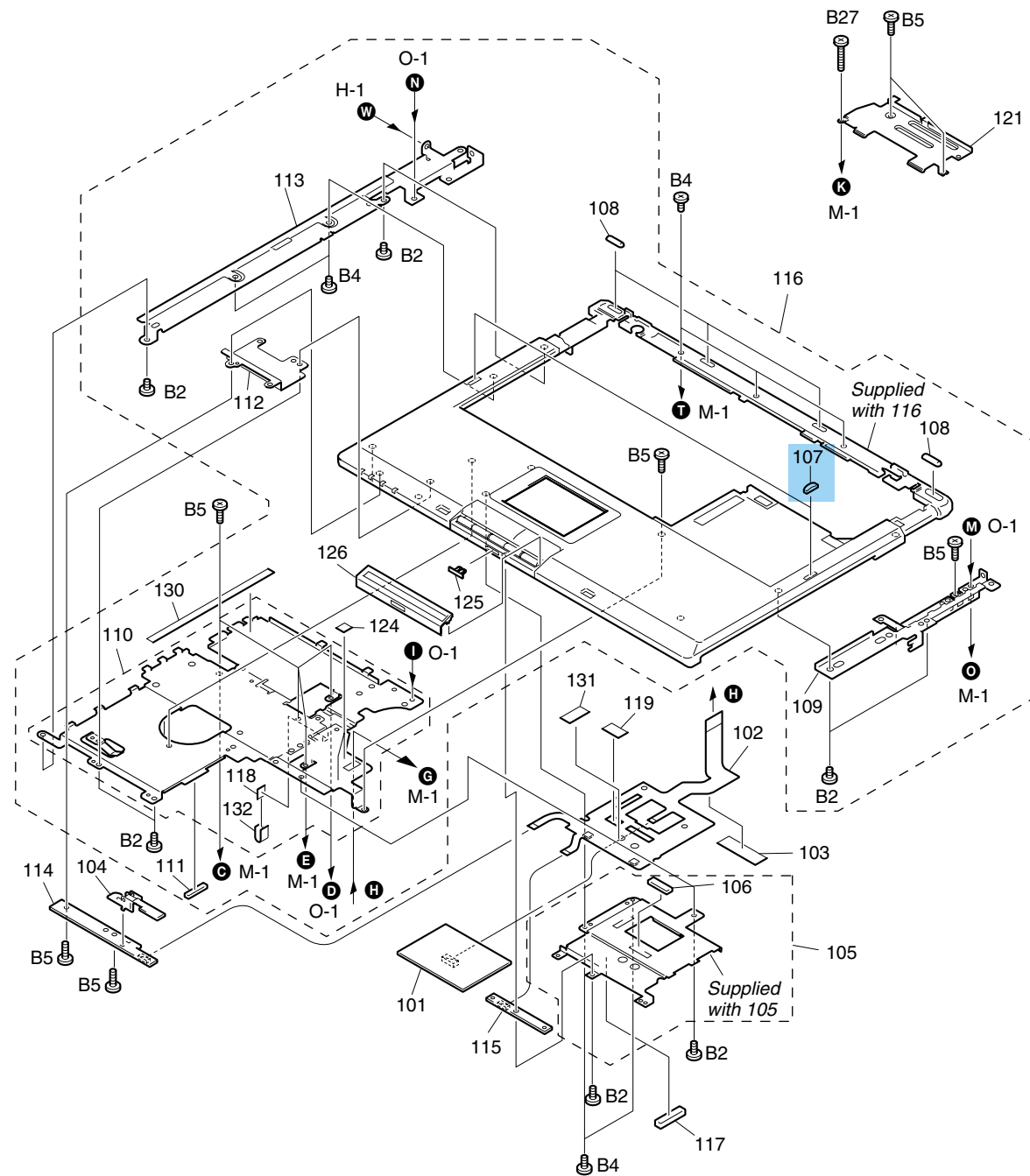

Ref.No.	Part No.	Description
101	1-796-319-41	PAD, TOUCH
102	9-885-033-60	PWB (H), FLEXIBLE PRINT
103	4-676-871-01	ADHESIVE TP FPC
104	X-4625-918-1	ASSY LATCH DETECTOR
* 105	X-4625-912-1	ASSY TP BRACKET
106	4-676-956-01	GASKET T/P CONTACT
107	4-668-288-11	& CUSHION PALM
108	4-676-948-01	RUBBER STOPPER
109	4-673-743-01	PALMREST BRACKET R
110	X-4625-910-1	ASSY PALMREST SHIELDING L
111	4-676-951-01	GASKET SHIELDING CONTACT
112	4-676-950-01	LEX BOARD PLATE
* 113	X-4626-178-1	ASSY PALMREST BRACKET L
114	A-8067-971-A	\$ COMPLETE PWB LEX-47
115	A-8067-972-A	\$ COMPLETE PWB SWX-142
117	4-677-786-01	GASKET CHARGER BOARD
118	4-677-944-01	GASKET CD-ROM BRACKET
119	4-676-954-01	ADHESIVE TP
* 121	X-4625-911-1	ASSY PALMREST SHIELDING R
124	4-677-945-01	SPACER BKT M
130	4-671-203-01	SHEET SHIELDING PALMREST
131	4-676-955-01	MYLAR TP
132	4-678-040-01	COPPER TAPE CD-ROM BKT
B2	4-669-867-01	SCREW (M2X4), SPECIAL HEAD
B4	4-641-726-81	SCREW (M2), SPECIAL HEAD
B5	4-641-726-41	SCREW (M2), SPECIAL HEAD
B27	4-678-226-01	M2-SCREW

Ref.No.	Part No.	Description	J			AM			EU			AO		
			GRT99/P	GRT77/B	GRT770 *	GRT170	GRT150	GRT100 *	GRT716S	GRT796HP	GRT796SP	GRT786M	GRT30P	GRT30LP
116	X-4625-906-1	ASSY PALMREST HOUSING			●	●	●	●	●	●	●	●	●	●
	X-4626-046-1	ASSY PALMREST HOUSING(TV)	●	●	●		●							
125	4-673-722-01	SLIDE WIRELESS KNOB			●	●			●	●		●	●	●
126	4-673-719-01	ESCUSHION W/O WIRELESS(TV)(16)	●	●	●			●						
	X-4625-908-1	ASSY ESCUSHION(TV)(16)						●						
	4-673-719-11	ESCUSHION W/O WIRELESS(16)					●	●			●			
	X-4626-219-1	ASSY ESCUSHION(16)				●		●		●	●	●	●	●

- This parts list contains two different types of parts.  
The first type is the parts that are common to all models.  
The other type is the parts that are different depending on each model.
- The model that is accompanied by asterisk (\*) is the CTO model.

- この部品表は、機種共通の部品と、機種によって使い分けが必要な部品に分かれています。
- 機種名に(\*)がつくのはCTOモデルです。



**Confidential**

PCG-GRT99/GRT77/GRT55 (J)  
 PCG-GRT170/GRT150/GRT25F/GRT160 (AM)  
 PCG-GRT716S/GRT796HP/GRT715E/  
 PCG-GRT795MP/GRT715M/GRT796SP (EU)  
 PCG-GRT30P/GRT25/GRT30LP/GRT30CP/GRT25CP (AO)

## P-2. Palmrest (15-inch Model)

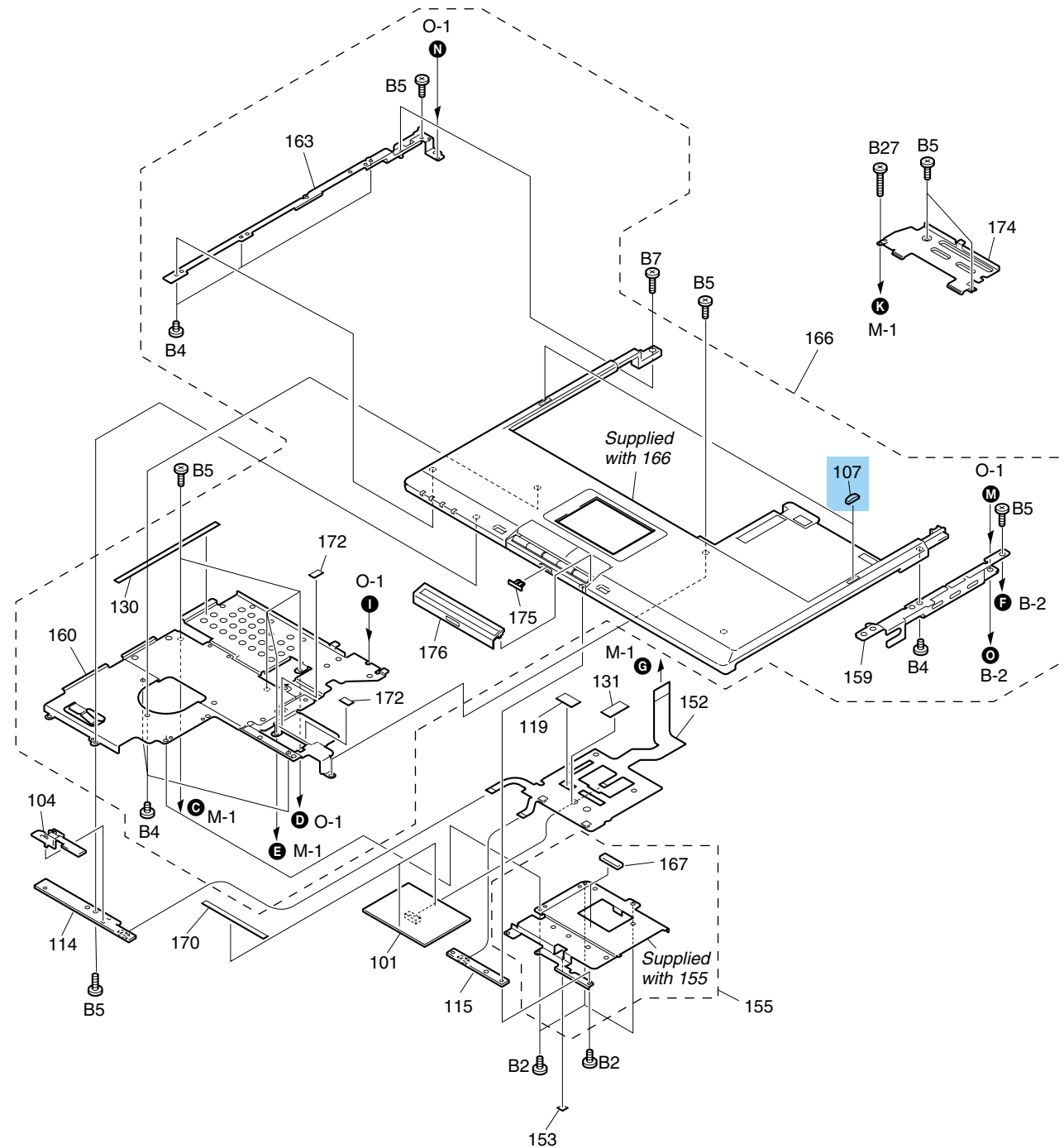

Ref.No.	Part No.	Description
101	1-796-319-41	PAD, TOUCH
104	X-4625-918-1	ASSY LATCH DETECTOR
107	4-668-288-11	& CUSHION PALM
114	A-8067-971-A	\$ COMPLETE PWB LEX-47
115	A-8067-972-A	\$ COMPLETE PWB SWX-142
119	4-676-954-01	ADHESIVE TP
130	4-671-203-01	SHEET SHIELDING PALMREST
131	4-676-955-01	MYLAR TP
152	9-885-033-61	PWB (M), FLEXIBLE PRINT
153	4-673-995-01	T/P-PW BD GASKET
155	4-673-798-01	TP BRACKET
159	4-673-797-01	BRACKET PALMREST R
160	X-4625-928-1	PALMREST SHIELDING L ASSY
163	4-673-796-01	BRACKET PALMREST L
167	4-673-994-01	T/P GASKET
170	4-677-676-01	TOUCH PAD ADHESIVE
172	4-677-673-01	SPACER BKT MYLAR
174	X-4625-929-1	PALMREST SHIELDING R ASSY
B2	4-669-867-01	SCREW (M2X4), SPECIAL HEAD
B4	4-641-726-81	SCREW (M2), SPECIAL HEAD
B5	4-641-726-41	SCREW (M2), SPECIAL HEAD
B7	4-677-186-01	SCREW M2X10L (K) B-ZY, NY
B27	4-678-226-01	M2-SCREW

Ref.No.	Part No.	Description	J	AM		EU		AO									
			GRT55/B	GRT750 *	GRT100 *	GRT25F	GRT160	GRT715E	GRT795MP	GRT715M	GRT785B	GRT785E	GRT25	GRT25CP	GRT25L		
166	X-4625-914-1	ASSY PALMREST HOUSING			●	●	●	●	●	●	●	●	●	●	●	●	●
	X-4625-945-1	ASSY PALMREST HOU (T)	●	●													
175	4-673-683-01	SLIDE WIRELESS KNOB				●											
176	4-673-701-01	ESCUSHION W/O WIRELESS(TV)(15)	●	●	●												
	X-4625-923-1	ASSY ESCUSHION(TV)(15)			●												
	4-673-701-11	ESCUSHION W/O WIRELESS(15)		●	●	●	●	●	●	●	●	●	●	●	●	●	●
	X-4625-225-1	ASSY ESCUSHION(15)				●		●									

△ [MA] △ [MA] △ [MA]

- This parts list contains two different types of parts. The first type is the parts that are common to all models. The other type is the parts that are different depending on each model.
- The model that is accompanied by asterisk (\*) is the CTO model.

- この部品表は、機種共通の部品と、機種によって使い分けが必要な部品に分かれています。
- 機種名に(\*)がつくのはCTOモデルです。

**Confidential**

PCG-GRT99/GRT77/GRT55 (J)  
 PCG-GRT170/GRT150/GRT25F/GRT160 (AM)  
 PCG-GRT716S/GRT796HP/GRT715E/  
 PCG-GRT795MP/GRT715M/GRT796SP (EU)  
 PCG-GRT30P/GRT25/GRT30LP/GRT30CP/GRT25CP (AO)

Bottom

B-1. Bottom (16-inch Model)

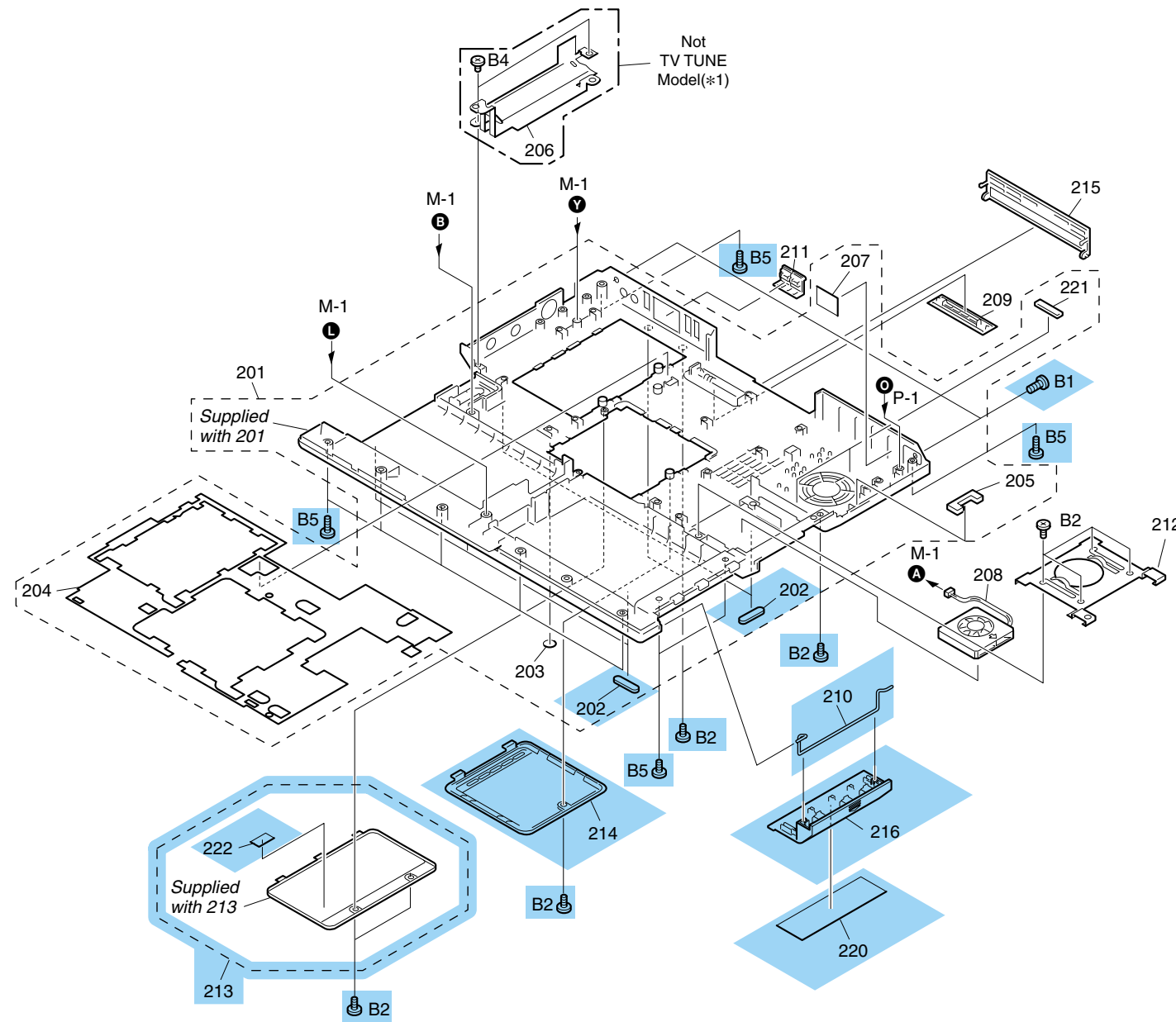

Ref.No.	Part No.	Description
202	4-668-294-11	& FOOT FRONT
203	4-654-380-41	CAP BAY
204	4-673-888-01	SHIELDING MYLAR
205	4-676-947-01	FERRITE CORE SPONGE
207	4-676-946-01	MYLAR BOTTOM OUTLET
208	A-8115-838-A	ASSY 3RD FAN COVER (PORT)
209	4-654-379-21	DOOR BATTERY SPRING
210	4-668-299-01	& CAP ETHERNET
211	4-673-986-01	3RD FAN SHIELDING ASSY
* 212	X-4625-933-1	
213	X-4625-934-1	& DOOR MDC ASSY
214	X-4625-917-1	& ASSY DOOR DIMM
215	X-4625-919-1	ASSY DOOR IO
216	4-673-714-01	& DOOR BATTERY
220	4-676-850-01	& LABEL BATTERY DOOR
221	4-676-461-01	LAN GASKET
222	4-677-682-01	& WIRELESS LAN GASKET
B1	4-654-811-01	& SCREW M3
B2	4-669-867-01	& SCREW (M2X4), SPECIAL HEAD
B4	4-641-726-81	SCREW (M2), SPECIAL HEAD
B5	4-641-726-41	& SCREW (M2), SPECIAL HEAD

Ref.No.	Part No.	Description	J			AM		EU			AO			
			GRT99/P	GRT77/B	GRT770 *	GRT170	GRT150	GRT100 *	GRT716S	GRT796HP	GRT796SP	GRT786M	GRT30P	GRT30LP
201	X-4625-988-1	ASSY HOUSING BOTTOM (T)(16)	●	●	●									
	X-4625-905-1	ASSY HOUSING BOTTOM(16)			●	●	●	●	●	●	●	●	●	●
206	4-673-748-01	BRACKET IO LEFT			●	●	●	●	●	●	●	●	●	●

- This parts list contains two different types of parts. The first type is the parts that are common to all models. The other type is the parts that are different depending on each model.
- The model that is accompanied by asterisk (\*) is the CTO model.

- この部品表は、機種共通の部品と、機種によって使い分けが必要な部品に分かれています。
- 機種名に(\*)がつくのはCTOモデルです。

\*1 For the BRACKET IO LEFT of the Tuner model, refer to the Main Board.

\*1 TVチューナーモデルのBRACKET IO LEFTは、Main Boardを参照ください。

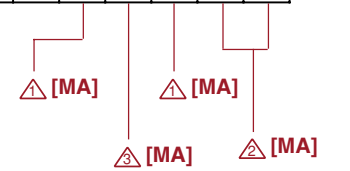

Confidential

PCG-GRT99/GRT77/GRT55 (J)  
 PCG-GRT170/GRT150/GRT25F/GRT160 (AM)  
 PCG-GRT716S/GRT796HP/GRT715E/  
 PCG-GRT795MP/GRT715M/GRT796SP (EU)  
 PCG-GRT30P/GRT25/GRT30LP/GRT30CP/GRT25CP (AO)

B-2. Bottom (15-inch Model)

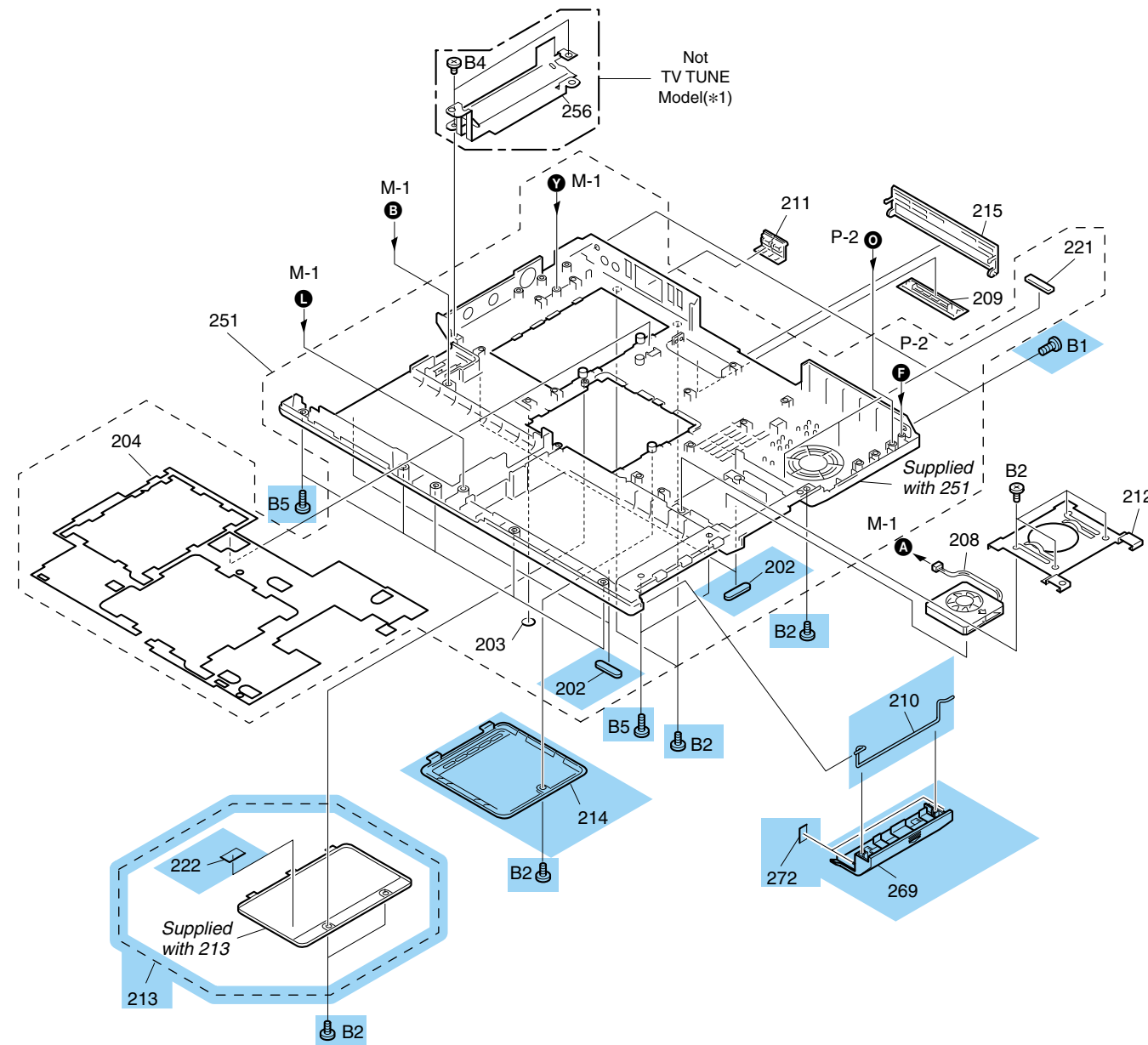

Ref.No.	Part No.	Description
202	4-668-294-11	& FOOT FRONT
203	4-654-380-41	CAP BAY
204	4-673-888-01	SHIELDING MYLAR
208	A-8115-838-A	ASSY 3RD FAN
209	4-654-379-21	COVER (PORT)
210	4-668-299-01	& DOOR BATTERY SPRING
211	4-673-986-01	CAP ETHERNET
* 212	X-4625-933-1	3RD FAN SHIELDING ASSY
213	X-4625-934-1	& DOOR MDC ASSY
214	X-4625-917-1	& ASSY DOOR DIMM
215	X-4625-919-1	ASSY DOOR IO
221	4-676-461-01	LAN GASKET
222	4-677-682-01	& WIRELESS LAN GASKET
269	4-673-714-01	& DOOR BATTERY
272	4-677-681-01	& SPONGE DOOR BATTERY
B1	4-654-811-01	& SCREW M3
B2	4-669-867-01	& SCREW (M2X4), SPECIAL HEAD
B4	4-641-726-81	SCREW (M2), SPECIAL HEAD
B5	4-641-726-41	& SCREW (M2), SPECIAL HEAD

Ref.No.	Part No.	Description	J		AM		EU			AO					
			GRT55/B	GRT750 *	GRT100 *	GRT25F	GRT160	GRT715E	GRT795MP	GRT715M	GRT785B	GRT785E	GRT25	GRT25CP	GRT25L
251	X-4625-924-1	ASSY HOUSING BOTTOM (T)(15)	●	●	●	●	●	●	●	●	●	●	●	●	●
	X-4625-913-1	ASSY HOUSING BOTTOM(15)				●	●	●	●	●	●	●	●	●	●
	256	BRACKET IO LEFT		●	●	●	●	●	●	●	●	●	●	●	●

△ [MA] △ [MA] △ [MA]

- This parts list contains two different types of parts. The first type is the parts that are common to all models. The other type is the parts that are different depending on each model.
- The model that is accompanied by asterisk (\*) is the CTO model.
- この部品表は、機種共通の部品と、機種によって使い分けが必要な部品に分かれています。
- 機種名に(\*)がつくのはCTOモデルです。

\*1 For the BRACKET IO LEFT of the Tuner model, refer to the Main Board.  
 \*1 TVチューナーモデルのBRACKET IO LEFTは、Main Boardを参照ください。

Confidential

PCG-GRT99/GRT77/GRT55 (J)  
 PCG-GRT170/GRT150/GRT25F/GRT160 (AM)  
 PCG-GRT716S/GRT796HP/GRT715E/  
 PCG-GRT795MP/GRT715M/GRT796SP (EU)  
 PCG-GRT30P/GRT25/GRT30LP/GRT30CP/GRT25CP (AO)

# M-1. Main Board

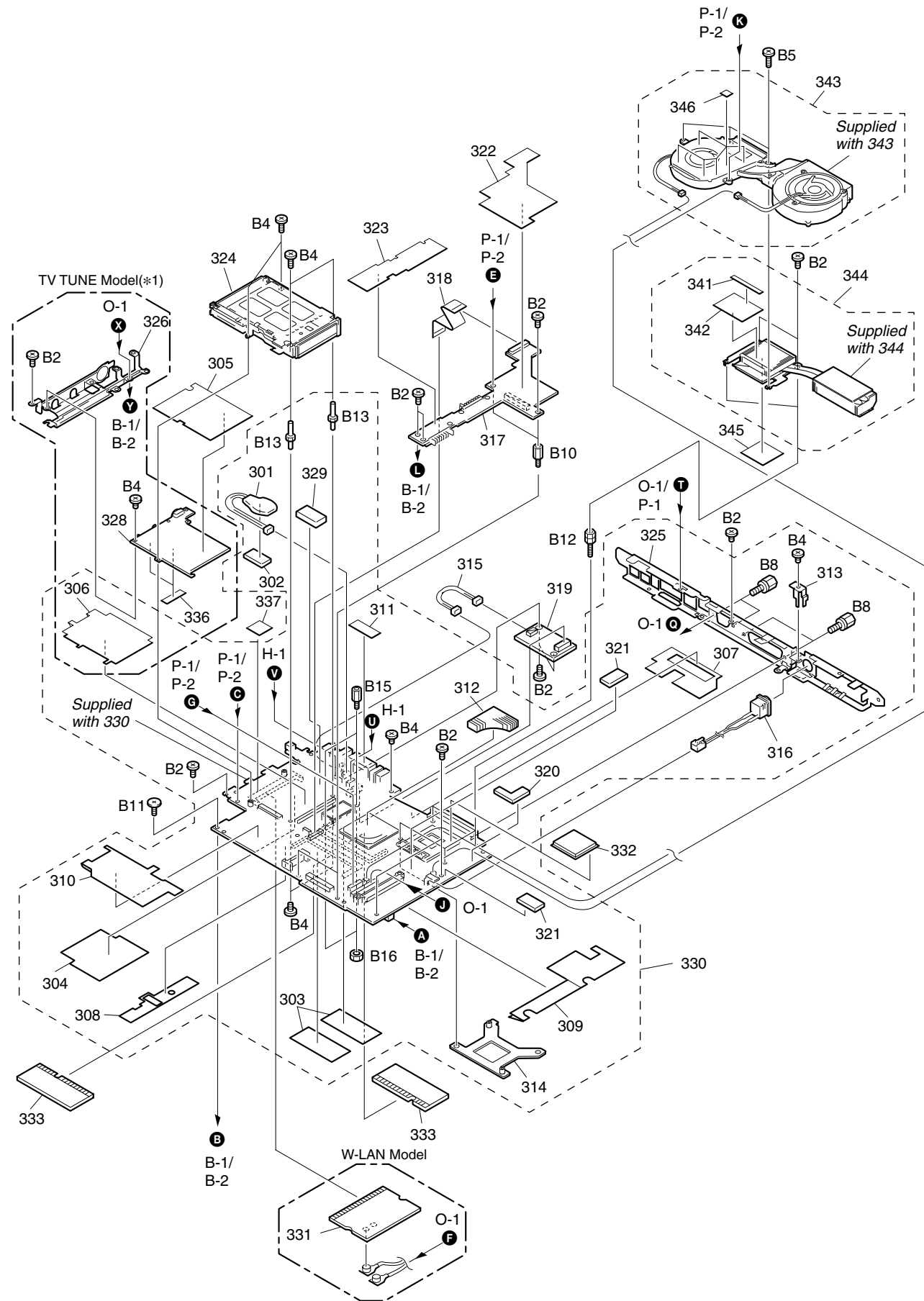

Ref.No.	Part No.	Description	Ref.No.	Part No.	Description
301	9-885-033-67	BATTERY, LITHIUM STORAGE	322	4-674-007-01	SHEET PWS 1
302	4-642-711-11	SHEET (BATTERY), ADHESIVE	323	4-674-008-01	SHEET PWS 2
303	4-668-307-01	SHEET DIMM	329	4-677-674-01	SPONGE CRYSTAL
304	4-668-308-01	SHEET MINI PCI	336	4-677-894-01	BUSTERAID TUNER
306	4-673-997-01	SHEET PC CARD	337	4-677-893-01	BUSTERAID MBX
307	4-673-999-01	SHEET PORT	341	4-677-183-01	FIN GASKET
308	4-674-000-01	SHEET DIMM SIDE	342	4-677-668-01	FIN MYLAR
309	4-674-001-01	SHEET HDD	343	A-8115-390-A	ASSY FAN UNIT
310	4-676-421-01	SHEET DRIVE	345	4-671-241-01	SHEET THERMAL (STH)
311	4-676-461-01	LAN GASKET 20X5X5X	346	4-677-182-01	FAN PLATE MYLAR
* 312	4-673-982-01	NORTH BRIDGE HEATSINK	B2	4-669-867-01	SCREW (M2X4), SPECIAL HEAD
* 313	4-673-811-01	DC IN HOLDER	B4	4-641-726-81	SCREW (M2), SPECIAL HEAD
* 314	X-4625-932-1	CPU BACK PLATE ASSY	B5	4-676-501-01	SCREW M2X6L,(K)B-NI,NY
315	9-885-033-65	HARNESS (2P)	B8	4-635-966-01	SCREW (HEX)
316	9-885-033-63	DC, HARNESS	B10	4-654-386-01	SPACER (PWS)
317	A-8067-969-A	\$ COMPLETE PWB PWS-27	B11	4-654-387-01	SCREW (MBX)
318	9-885-033-72	CABLE (30P), FLEXIBLE FLAT	B12	4-676-485-01	SPACER(CPU)
319	1-761-606-13	\$ # CARD, MODEM	B13	4-677-686-01	SPACER (PWS) H=8.0
320	4-674-004-01	CMOS PAD U	B15	4-654-385-01	SPACER (VIF)
321	4-674-005-01	CMOS PAD L	B16	7-622-205-05	NUT (M2 TYPE2), HEXAGON

Ref.No.	Part No.	Description	↓		AM				EU				AO															
			GRT99/P	GRT77B	GRT55B	GRT770*	GRT750*	GRT170	GRT150	GRT100*	GRT25F	GRT160	GRT716S	GRT796HP	GRT715E	GRT795MP	GRT715M	GRT796SP	GRT786M	GRT785B	GRT786E	GRT30P	GRT25	GRT30LP	GRT30CP	GRT25CP	GRT25L	
305	4-674-003-01	TUNER BD MYLAR	•	•	•	•	•	•	•	•	•	•	•	•	•	•	•	•	•	•	•	•	•	•	•	•	•	•
324	9-885-033-66	CONNECTOR PC CARD (1 SLOT)	•	•	•	•	•	•	•	•	•	•	•	•	•	•	•	•	•	•	•	•	•	•	•	•	•	•
	9-885-033-62	CONNECTOR PC CARD (2 SLOT)	•	•	•	•	•	•	•	•	•	•	•	•	•	•	•	•	•	•	•	•	•	•	•	•	•	•
*	325	X-4626-179-1	•	•	•	•	•	•	•	•	•	•	•	•	•	•	•	•	•	•	•	•	•	•	•	•	•	•
	X-4625-954-1	ASSY BRACKET I/O(15)	•	•	•	•	•	•	•	•	•	•	•	•	•	•	•	•	•	•	•	•	•	•	•	•	•	•
*	326	X-4625-909-1	•	•	•	•	•	•	•	•	•	•	•	•	•	•	•	•	•	•	•	•	•	•	•	•	•	•
	X-4625-935-1	ASSY BRACKET IO LEFT (T) (15)	•	•	•	•	•	•	•	•	•	•	•	•	•	•	•	•	•	•	•	•	•	•	•	•	•	•
328	A-8067-973-A	COMPLETE PWB ENX-23(J)	•	•	•	•	•	•	•	•	•	•	•	•	•	•	•	•	•	•	•	•	•	•	•	•	•	•
	A-8067-974-A	COMPLETE PWB ENX-23(U)	•	•	•	•	•	•	•	•	•	•	•	•	•	•	•	•	•	•	•	•	•	•	•	•	•	•
330	A-8115-749-A	\$ # COMPL MBX-86(T)(16)(S)	•	•	•	•	•	•	•	•	•	•	•	•	•	•	•	•	•	•	•	•	•	•	•	•	•	•
	A-8115-748-A	\$ # COMPL MBX-86(16)(S)	•	•	•	•	•	•	•	•	•	•	•	•	•	•	•	•	•	•	•	•	•	•	•	•	•	•
	A-8115-747-A	\$ # COMPL MBX-86(T)(15)(S)	•	•	•	•	•	•	•	•	•	•	•	•	•	•	•	•	•	•	•	•	•	•	•	•	•	•
	A-8115-746-A	\$ # COMPL MBX-86(15)(S)	•	•	•	•	•	•	•	•	•	•	•	•	•	•	•	•	•	•	•	•	•	•	•	•	•	•
331	1-761-648-32	\$ # CARD, WIRELESS LAN (FCC)	•	•	•	•	•	•	•	•	•	•	•	•	•	•	•	•	•	•	•	•	•	•	•	•	•	•
332	6-704-133-01	IC RK80532PE072512SL6S4(P4 2.8)	•	•	•	•	•	•	•	•	•	•	•	•	•	•	•	•	•	•	•	•	•	•	•	•	•	•
	6-704-132-01	IC RK80532PE06751SL6S3(P4 2.66)	•	•	•	•	•	•	•	•	•	•	•	•	•	•	•	•	•	•	•	•	•	•	•	•	•	•
	6-704-128-01	IC RK80532PE056512SL6RZ(P4 2.4)	•	•	•	•	•	•	•	•	•	•	•	•	•	•	•	•	•	•	•	•	•	•	•	•	•	•
	6-703-333-01	IC RH80532GC041512-2(P4-M 2.0)	•	•	•	•	•	•	•	•	•	•	•	•	•	•	•	•	•	•	•	•	•	•	•	•	•	•
	6-703-826-01	IC RH80532NC033256(C 1.8)	•	•	•	•	•	•	•	•	•	•	•	•	•	•	•	•	•	•	•	•	•	•	•	•	•	•
	6-703-846-01	IC RH80532GC049512(P4-M 2.2)	•	•	•	•	•	•	•	•	•	•	•	•	•	•	•	•	•	•	•	•	•	•	•	•	•	•
	6-704-320-01	IC RH80532GC060512(P4-M 2.5)	•	•	•	•	•	•	•	•	•	•	•	•	•	•	•	•	•	•	•	•	•	•	•	•	•	•
333	6-704-105-01	IC HYS64D64020GBDL-7-B(DDR 512MB)	•	•	•	•	•	•	•	•	•	•	•	•	•	•	•	•	•	•	•	•	•	•	•	•	•	•
333	6-704-094-01	IC MT8VDDT3264HDG-265C3(DDR 256MB)	•	•	•	•	•	•	•	•	•	•	•	•	•	•	•	•	•	•	•	•	•	•	•	•	•	•
344	4-673-983-01	\$ FIN MODULE STH	•	•	•	•	•	•	•	•	•	•	•	•	•	•	•	•	•	•	•	•	•	•	•	•	•	•
	4-673-984-01	\$ FIN MODULE MOBILE	•	•	•	•	•	•	•	•	•	•	•	•	•	•	•	•	•	•	•	•	•	•	•	•	•	•



- This parts list contains two different types of parts.  
The first type is the parts that are common to all models.  
The other type is the parts that are different depending on each model.
- The model that is accompanied by asterisk (\*) is the CTO model.
- この部品表は、機種共通の部品と、機種によって使い分けが必要な部品に分かれています。  
• 機種名に (\*) がつくのは CTO モデルです。

\*1 For the BRACKET IO LEFT of the model without Tuner, refer to the Bottom.  
\*1 TVチューナーのないモデルのBRACKET IO LEFTは、Bottomを参照ください。

Confidential

PCG-GRT99/GRT77/GRT55 (J)  
PCG-GRT170/GRT150/GRT25F/GRT160 (AM)  
PCG-GRT716S/GRT796HP/GRT715E/  
PCG-GRT795MP/GRT715M/GRT796SP (EU)  
PCG-GRT30P/GRT25/GRT30LP/GRT30CP/GRT25CP (AO)

# H-1. Hood Keyboard

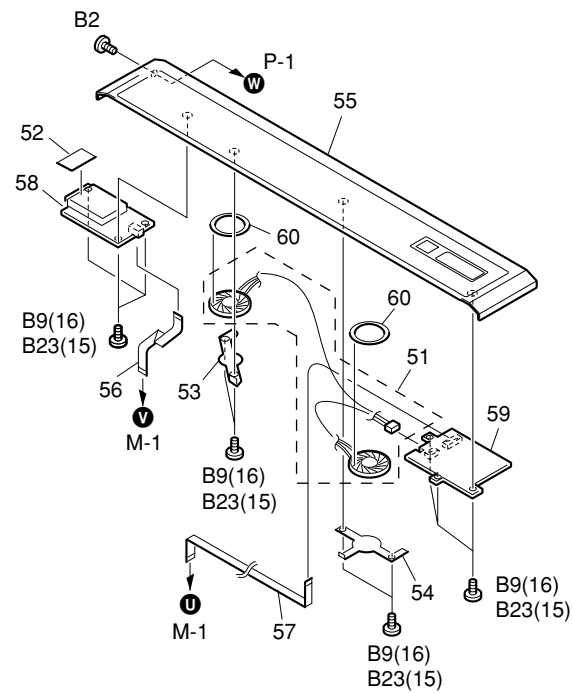

Ref.No.	Part No.	Description
52	4-671-590-01	SHEET (MS) (C)
53	4-673-789-01	SPEAKER HOLDER L
56	9-885-033-70	CABLE (10P), FLEXIBLE FLAT
57	9-885-033-71	CABLE (11P), FLEXIBLE FLAT
58	A-8067-977-A	COMPLETE PWB IFX-257
59	A-8067-976-A	COMPLETE PWB SWX-137
60	4-677-458-01	SPEAKER RING GULE
B2	4-669-867-01	SCREW (M2X4), SPECIAL HEAD

Ref.No.	Part No.	Description	J		AM				EU				AO														
			GRT99/P	GRT77/B	GRT55/B	GRT77/0*	GRT75/0*	GRT17/0	GRT15/0	GRT100*	GRT25/F	GRT16/0	GRT71/6S	GRT796HP	GRT715E	GRT795MP	GRT715M	GRT796SP	GRT786M	GRT785B	GRT785E	GRT30P	GRT25	GRT30LP	GRT30CP	GRT25CP	GRT25L
51	A-8116-009-A	SPEAKER UNIT(16)	●	●	●	●	●	●	●	●	●	●	●	●	●	●	●	●	●	●	●	●	●	●	●	●	●
	9-885-033-59	SPEAKER UNIT(15)	●	●	●	●	●	●	●	●	●	●	●	●	●	●	●	●	●	●	●	●	●	●	●	●	●
54	4-673-747-01	SPEAKER HOLDER R(16)	●	●	●	●	●	●	●	●	●	●	●	●	●	●	●	●	●	●	●	●	●	●	●	●	●
	4-673-790-01	SPEAKER HOLDER R(15)	●	●	●	●	●	●	●	●	●	●	●	●	●	●	●	●	●	●	●	●	●	●	●	●	●
55	X-4625-907-1	ASSY HOOD KEYBOARD(16)	●	●	●	●	●	●	●	●	●	●	●	●	●	●	●	●	●	●	●	●	●	●	●	●	●
	X-4625-915-1	ASSY HOOD KEYBOARD(15)	●	●	●	●	●	●	●	●	●	●	●	●	●	●	●	●	●	●	●	●	●	●	●	●	●
B9	4-645-177-01	SCREW (M1.7X3.5)	●	●	●	●	●	●	●	●	●	●	●	●	●	●	●	●	●	●	●	●	●	●	●	●	●
B23	4-639-112-01	SCREW (M2X4)	●	●	●	●	●	●	●	●	●	●	●	●	●	●	●	●	●	●	●	●	●	●	●	●	●



- This parts list contains two different types of parts.  
The first type is the parts that are common to all models.  
The other type is the parts that are different depending on each model.
- The model that is accompanied by asterisk (\*) is the CTO model.

- この部品表は、機種共通の部品と、機種によって使い分けが必要な部品に分かれています。
- 機種名に(\*)がつくのはCTOモデルです。

**Confidential**

PCG-GRT99/GRT77/GRT55 (J)  
 PCG-GRT170/GRT150/GRT25F/GRT160 (AM)  
 PCG-GRT716S/GRT796HP/GRT715E/  
 PCG-GRT795MP/GRT715M/GRT796SP (EU)  
 PCG-GRT30P/GRT25/GRT30LP/GRT30CP/GRT25CP (AO)

O-1. Other Parts

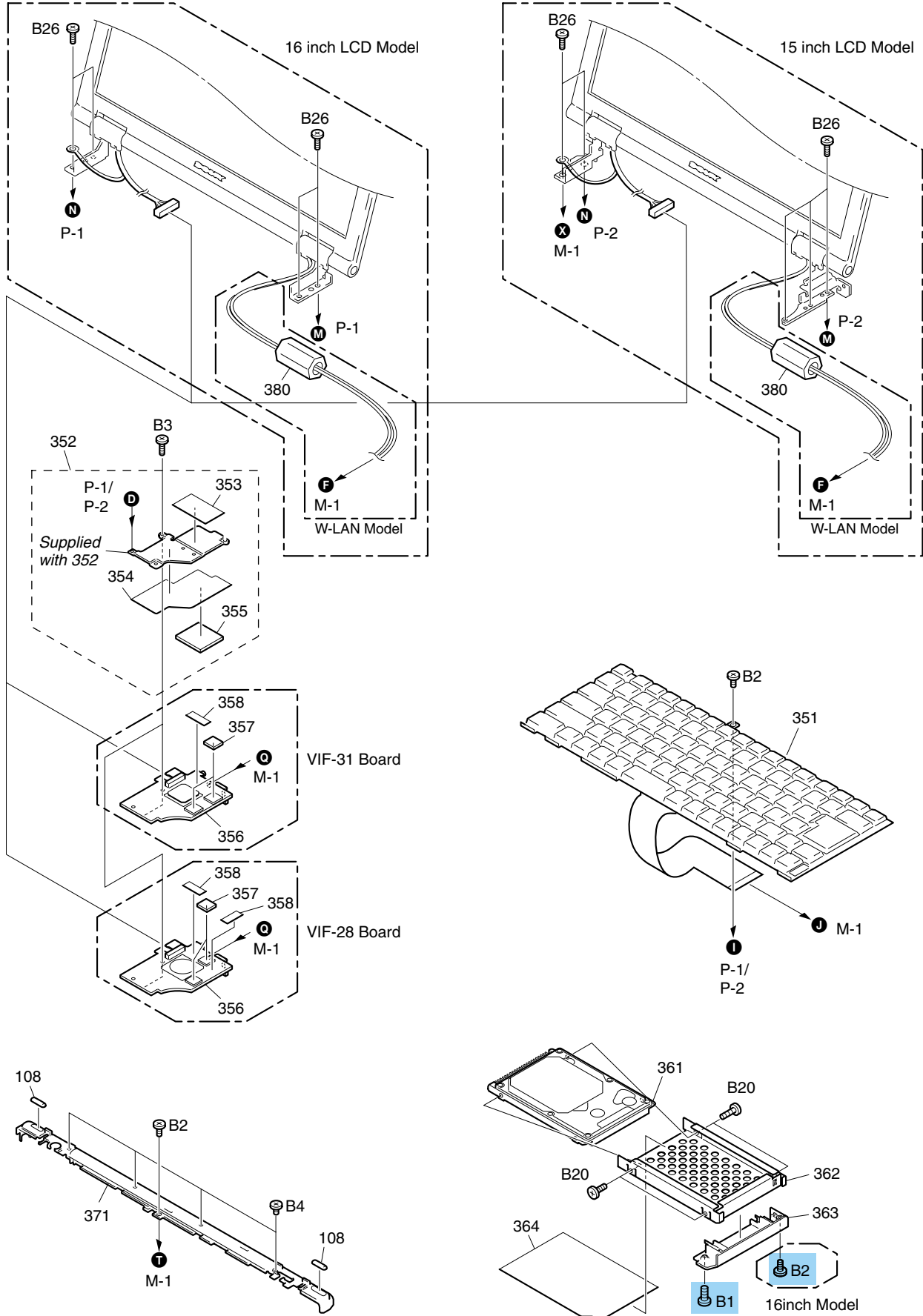

Ref.No.	Part No.	Description
352	X-4625-931-1	VGA HEAT PLATE ASSY
353	4-670-461-01	SHEET BLIND(PLATE HEATSINK)
354	4-673-987-01	VGA PLATE MYLAR
355	4-676-423-01	VGA THERMAL PAD
357	4-677-667-01	VGA PAD
358	4-677-943-01	VGA MYLAR
B1	4-654-811-21	& SCREW M3
B2	4-669-867-01	& SCREW (M2X4), SPECIAL HEAD
B3	4-676-501-01	SCREW M2X6L,(K)B-NI,NY
B4	4-641-726-81	SCREW (M2), SPECIAL HEAD
B20	4-635-301-11	SCREW M3X4
B26	4-644-637-01	GRIP, M2 EG

Ref.No.	Part No.	Description	J										AM				EU				AO						
			GRT99P	GRT77B	GRT55B	GRT770*	GRT750*	GRT170	GRT150	GRT100*	GRT25F	GRT160	GRT716S	GRT798HP	GRT715E	GRT795MP	GRT715M	GRT796SP	GRT796M	GRT795B	GRT795E	GRT30P	GRT25	GRT30LP	GRT30CP	GRT25CP	GRT25L
108	4-676-948-01	RUBBER STOPPER																									
351	1-478-018-11	\$ # KEY BOARD UNIT (JP)																									
	1-478-018-21	\$ # KEY BOARD UNIT (US)																									
	1-478-023-11	\$ # (UK/Dutch)...KEY BOARD UNIT (GB)																									
	1-478-023-21	\$ # (German)...KEY BOARD UNIT (DE)																									
	1-478-023-31	\$ # (Swiss)...KEY BOARD UNIT (CH)																									
	1-478-023-41	\$ # (French)...KEY BOARD UNIT (FR)																									
	1-478-023-51	\$ # (Italian)...KEY BOARD UNIT (IT)																									
	1-478-023-81	\$ # (Spanish)...KEY BOARD UNIT (ES)																									
	1-478-023-61	\$ # KEY BOARD UNIT (LA)																									
	1-478-018-31	\$ # KEY BOARD UNIT (KR)																									
356	A-8067-970-A	\$ COMPLETE PWB VIF-31																									
	A-8067-978-A	\$ COMPLETE PWB VIF-28																									
361	A-8067-943-A	\$ # ASSY HDD 80GB (L40) (S)																									
	A-8113-861-A	\$ # ASSY HDD 60GB(T-A) (S)																									
	A-8111-360-A	\$ # ASSY HDD 60GB(T,30)(S)																									
	A-8113-859-A	\$ # ASSY HDD 40GB(H) (S)																									
	A-8115-795-A	\$ # ASSY HDD 40GB(F,30)(S)																									
	A-8113-860-A	\$ # ASSY HDD 30GB(H)(S)																									
362	4-676-418-01	BRACKET HDD(16)																									
	4-653-799-01	BRACKET HDD(15)																									
363	4-673-715-01	DOOR HDD(16)																									
	4-673-686-01	DOOR HDD(15)																									
364	4-653-801-01	SHEET HDD(16)																									
	4-674-001-01	SHEET HDD(15)																									
371	X-4625-916-1	ASSY DISPLAY BASE																									
380	1-400-255-21	FERRITE CORE																									

△ [MA]  
△ [MA]

△ [MA]  
△ [MA]  
△ [MA]  
△ [MA]  
△ [MA]  
△ [MA]

- This parts list contains two different types of parts.  
The first type is the parts that are common to all models.  
The other type is the parts that are different depending on each model.
- The model that is accompanied by asterisk (\*) is the CTO model.

• この部品表は、機種共通の部品と、機種によって使い分けが必要な部品に分かれています。  
• 機種名に(\*)がつくのはCTOモデルです。

Confidential

PCG-GRT99/GRT77/GRT55 (J)  
PCG-GRT170/GRT150/GRT25F/GRT160 (AM)  
PCG-GRT716S/GRT796HP/GRT715E/  
PCG-GRT795MP/GRT715M/GRT796SP (EU)  
PCG-GRT30P/GRT25/GRT30LP/GRT30CP/GRT25CP (AO)

**LCD**  
**L-1. 16-inch SXGA**  
**– Made by SH –**

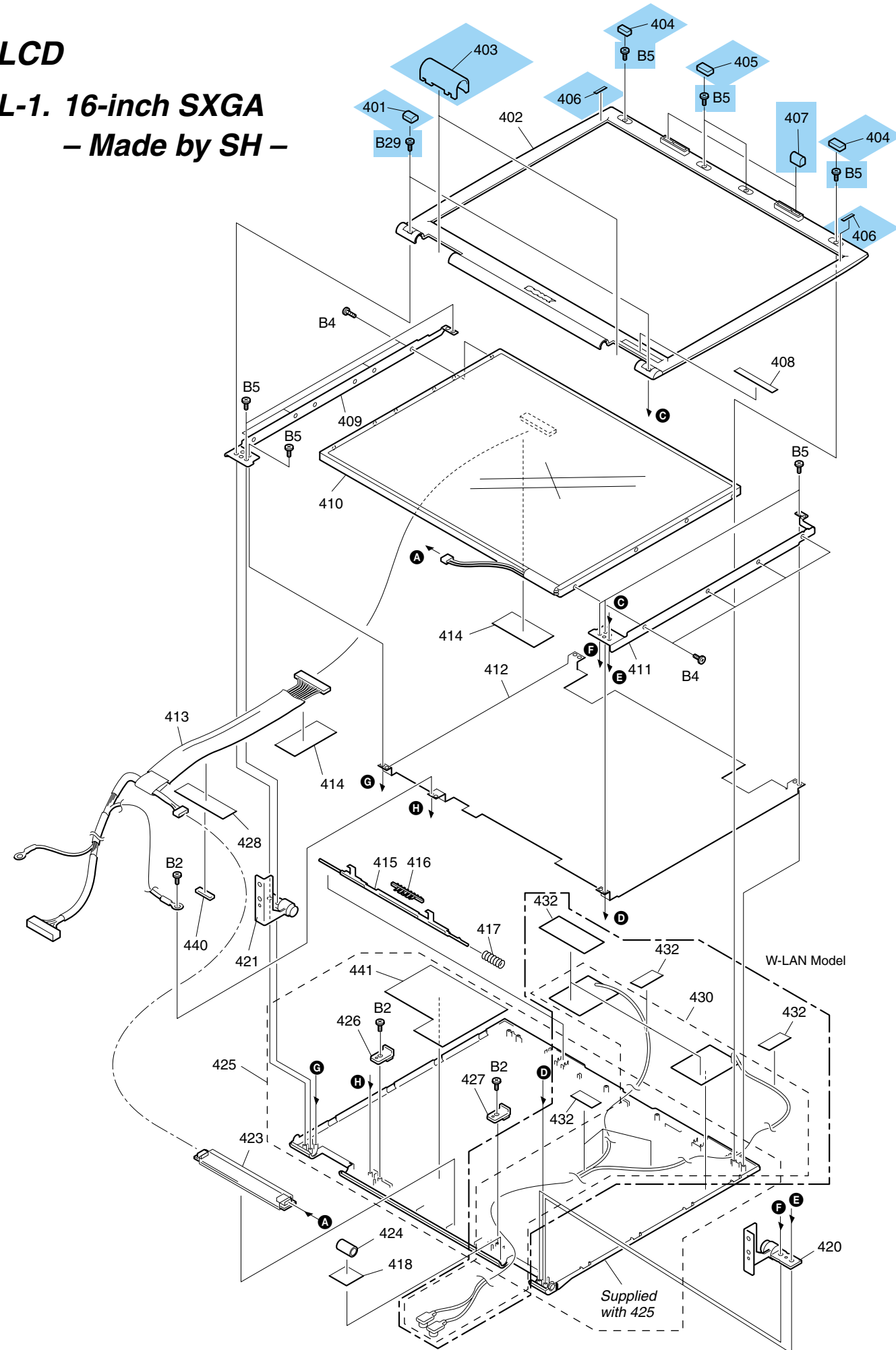

Ref.No.	Part No.	Description
401	4-674-542-01	& COVER SCREW LOWER
402	A-8115-904-A	ASSY HOUSING BEZEL/SH
403	4-667-073-11	& COVER HINGE
404	4-674-540-01	& COVER SCREW UPPER
405	4-674-541-01	& COVER SCREW MIDDLE
406	4-672-201-11	& CUSHION BEZEL
407	4-674-539-01	& CUSHION LATCH
409	4-673-753-01	BRACKET LCD SH L
410	A-8112-385-A	\$ # LCD TFT 16.1" SXGA
411	4-673-752-01	BRACKET LCD SH R
412	4-676-870-01	SHIELD DISPLAY
413	9-885-031-90	LCD CABLE
414	4-677-679-01	FOIL LCD HARNESS
415	4-673-727-01	LATCH HONTAI
416	4-673-728-01	LATCH BUTTON
417	4-671-640-01	GT2 SPRING_LATCH
418	4-670-046-01	GT2 CUSHION WL CABLE
420	4-673-736-01	HINGE R
421	4-673-735-01	HINGE L
423	1-476-316-31	INVERTER UNIT
425	A-8115-902-A	ASSY HOUSING DISPLAY
426	4-673-730-01	LCD HOOK BASE L SH
427	4-673-731-01	LCD HOOK BASE R SH
428	4-672-403-01	COPPER TAPE LCD ED
440	4-676-424-01	LAN GASKET
441	4-677-784-01	FOIL INVERTER
B2	4-669-867-01	SCREW (M2X4), SPECIAL HEAD
B4	4-641-726-81	SCREW (M2), SPECIAL HEAD
B5	4-641-726-41	& SCREW M2X6L,(K)B-NI,NY
B29	4-641-726-91	& SCREW (M2), SPECIAL HEAD

Ref.No.	Part No.	Description	AM	
			GRT150	GRT100*
408	4-676-187-41	LABEL ID	•	
424	4-670-045-01	GT2 TUBE WL CABLE		•
430	1-754-295-11	ANTENNA, FILM (L AND R)		•
432	—————	FILAMENT TAPE		•

- This parts list contains two different types of parts.  
 The first type is the parts that are common to all models.  
 The other type is the parts that are different depending on each model.
- The model that is accompanied by asterisk (\*) is the CTO model.
- この部品表は、機種共通の部品と、機種によって使い分けが必要な部品に分かれています。  
 ・機種名に(\*)がつくのはCTOモデルです。



**L-2. 16-inch UXGA, SXGA  
(Clear Black)  
-Made by HI-**

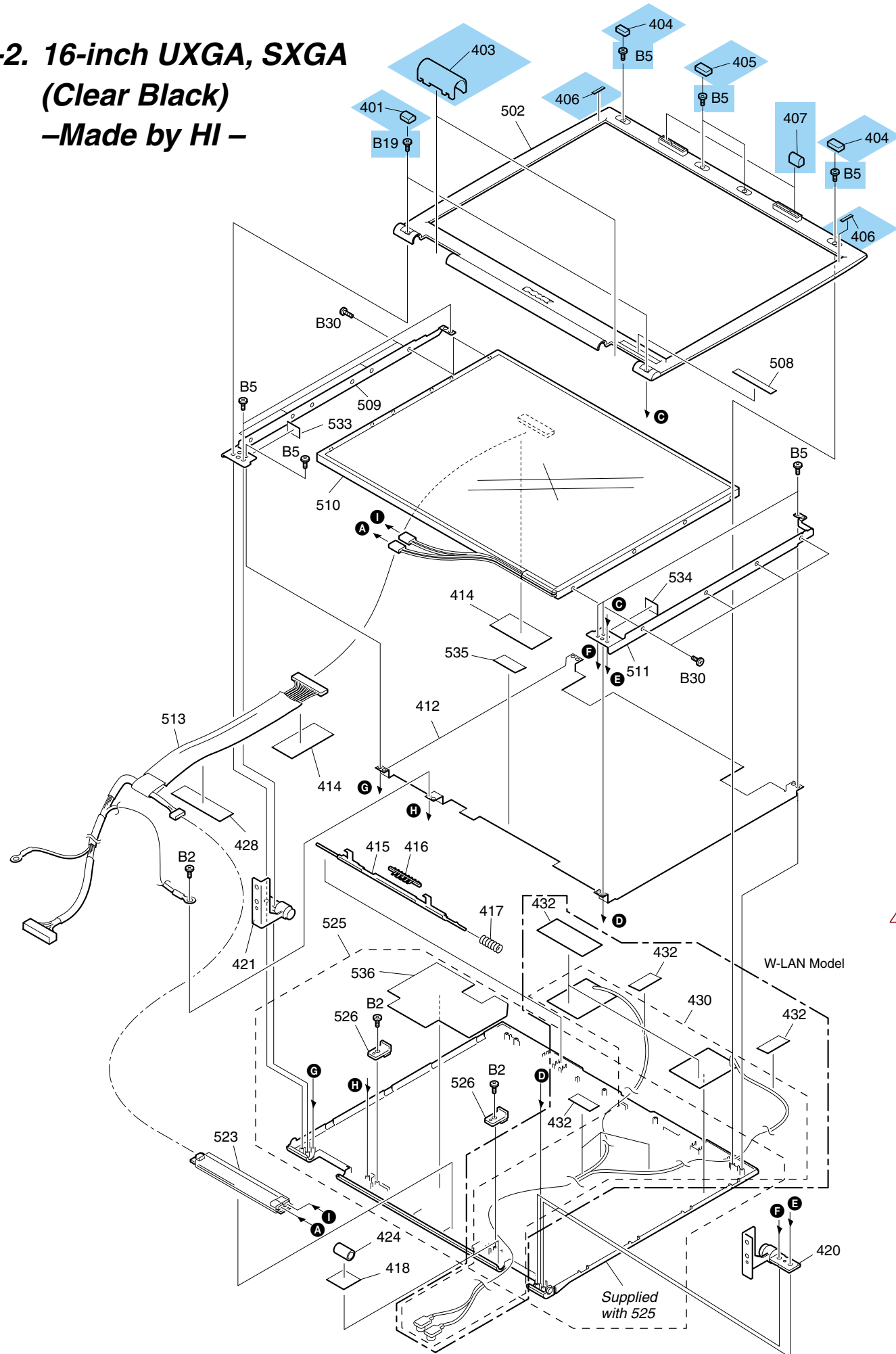

Ref.No.	Part No.	Description
401	4-674-542-01	& COVER SCREW LOWER
403	4-667-073-11	& COVER HINGE
404	4-674-540-01	& COVER SCREW UPPER
405	4-674-541-01	& COVER SCREW MIDDLE
406	4-672-201-11	& CUSHION BEZEL
407	4-674-539-01	& CUSHION LATCH
412	4-676-870-01	SHIELD DISPLAY
414	4-677-679-01	FOIL LCD HARNESS
415	4-673-727-01	LATCH HONTAI
416	4-673-728-01	LATCH BUTTON
417	4-671-640-01	GT2 SPRING_LATCH
418	4-670-046-01	GT2 CUSHION WL CABLE
420	4-673-736-01	HINGE R
421	4-673-735-01	HINGE L
428	4-672-403-01	COPPER TAPE LCD ED
502	A-8115-903-A	ASSY HOUSING BEZEL/HI
509	4-673-750-01	BRACKET LCD HI L
511	4-673-749-01	BRACKET LCD HI R
513	9-885-031-89	LCD CABLE
523	1-478-040-11	INVERTER UNIT
525	A-8115-984-A	ASSY HOUSING DISPLAY 16(SBL)(S)
526	4-673-729-01	LCD HOOK BASE HI
533	4-676-481-01	SHEET BRACKET LCD L HIT
534	4-676-482-01	SHEET BRACKET LCD R HIT
535	4-670-396-01	SHEET COPPER(PLATE HEATSINK)
536	4-676-932-01	PLATE INVERTER
B2	4-669-867-01	SCREW (M2X4), SPECIAL HEAD
B5	4-641-726-41	& SCREW (M2), SPECIAL HEAD
B19	4-641-726-91	& SCREW (M2), SPECIAL HEAD
B30	4-636-559-01	SCREW (M2.5X4)

Ref.No.	Part No.	Description	J		AM	EU
			GRT99/P	GRT77/B	GRT770 *	GRT100 *
424	4-670-045-01	GT2 TUBE WL CABLE			●	
430	1-754-295-11	ANTENNA, FILM (L AND R)			●	
432		FILAMENT TAPE			●	
508	4-676-187-01	LABEL ID	●			
	4-676-187-31	LABEL ID		●		
	4-676-191-01	LABEL ID				●
	4-676-191-61	LABEL ID				●
510	A-8115-722-A \$ #	LCD TFT 16.0" UXGA-HI	●	●	●	●
	A-8115-721-A \$ #	LCD TFT 16.0" SXGA+HI		●	●	●

△ [MA]

△ [MA]

- This parts list contains two different types of parts.  
The first type is the parts that are common to all models.  
The other type is the parts that are different depending on each model.
- The model that is accompanied by asterisk (\*) is the CTO model.
- この部品表は、機種共通の部品と、機種によって使い分けが必要な部品に分かれています。  
• 機種名に (\*) がつくのは CTO モデルです。

**L-3. 16-inch UXGA, SXGA  
(Normal)  
-Made by HI-**

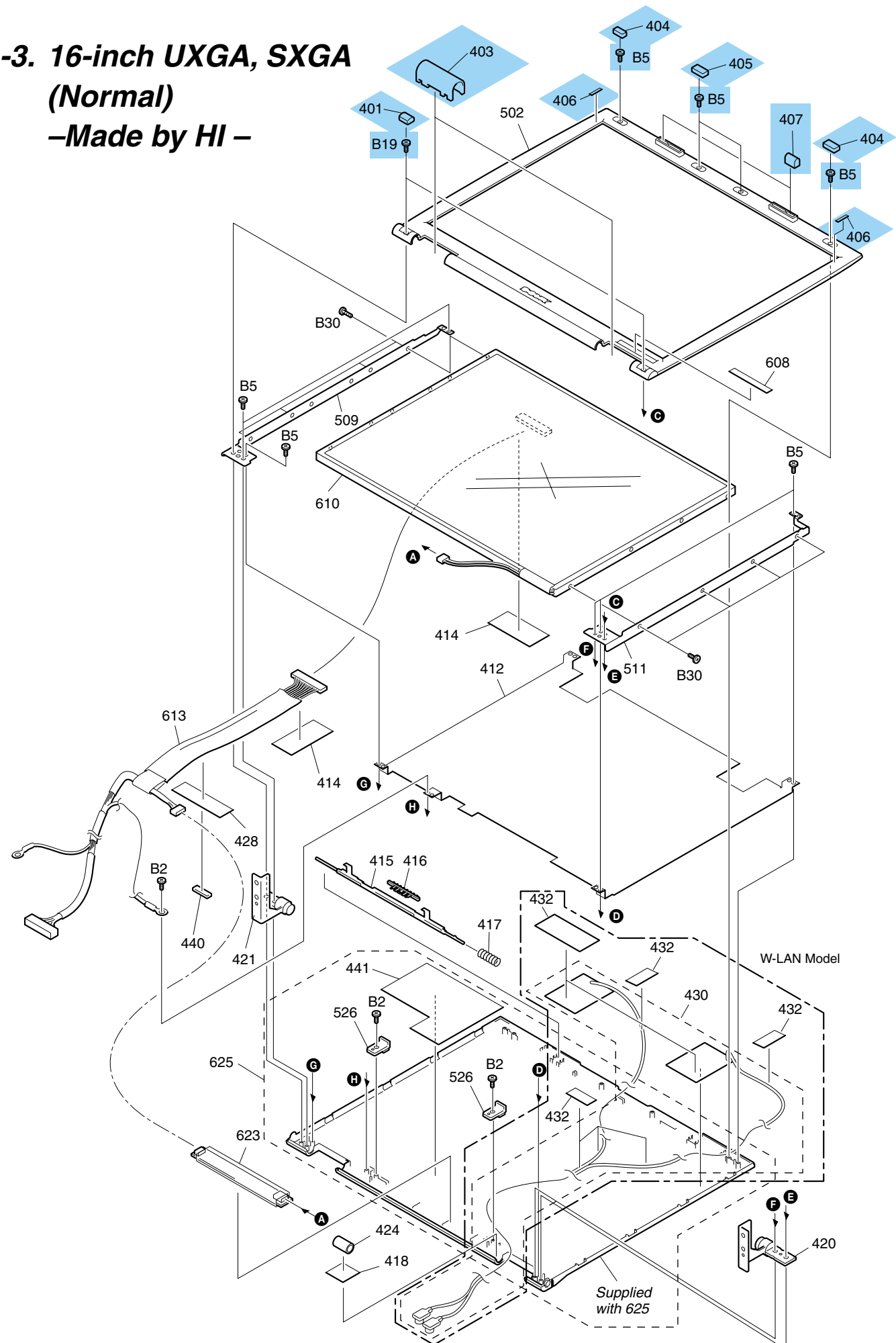

Ref.No.	Part No.	Description
401	4-674-542-01	& COVER SCREW LOWER
403	4-667-073-11	& COVER HINGE
404	4-674-540-01	& COVER SCREW UPPER
405	4-674-541-01	& COVER SCREW MIDDLE
406	4-672-201-11	& CUSHION BEZEL
407	4-674-539-01	& CUSHION LATCH
412	4-676-870-01	SHIELD DISPLAY
414	4-677-679-01	FOIL LCD HARNESS
415	4-673-727-01	LATCH HONTAI
416	4-673-728-01	LATCH BUTTON
417	4-671-640-01	GT2 SPRING LATCH
418	4-670-046-01	GT2 CUSHION WL CABLE
420	4-673-736-01	HINGE R
421	4-673-735-01	HINGE L
428	4-672-403-01	COPPER TAPE LCD ED
440	4-676-424-01	LAN GASKET
441	4-677-784-01	FOIL INVERTER
502	A-8115-903-A	ASSY HOUSING BEZEL/HI
509	4-673-750-01	BRACKET LCD HI L
511	4-673-749-01	BRACKET LCD HI R
526	4-673-729-01	LCD HOOK BASE HI
613	9-885-031-91	LCD CABLE
623	1-477-101-11	INVERTER UNIT
625	A-8115-983-A	ASSY HOUSING DISPLAY 16(HI)(S)
B2	4-669-867-01	SCREW (M2X4), SPECIAL HEAD
B5	4-641-726-41	& SCREW (M2), SPECIAL HEAD
B19	4-641-726-91	& SCREW (M2), SPECIAL HEAD
B30	4-636-559-01	SCREW (M2.5X4)

Ref.No.	Part No.	Description	J	AM	EU	AO				
			GRT770 *	GRT170	GRT100 *	GRT796HP	GRT796SP	GRT30P	GRT30LP	GRT30CP
424	4-670-045-01	GT2 TUBE WL CABLE		●	●	●	●	●	●	●
430	1-754-295-11	ANTENNA, FILM (L AND R)		●	●	●	●	●	●	●
432		FILAMENT TAPE		●	●	●	●	●	●	●
608	4-676-187-21	LABEL ID		●						
	4-676-191-21	LABEL ID				●				
	4-676-191-11	LABEL ID					●			
	4-676-188-11	LABEL ID						●		
	4-676-188-21	LABEL ID							●	
	4-676-192-01	LABEL ID								●
610	A-8059-922-A \$ #	ASSY LCD 16 U(SH)(S)	●	●	●	●	●	●	●	●
	A-8067-707-A \$ #	ASSY LCD 16SXGA(HI)(S)	●	●	●	●	●	●	●	●

△ [MA]  
△ [MA]  
△ [MA]

- This parts list contains two different types of parts. The first type is the parts that are common to all models. The other type is the parts that are different depending on each model.
- The model that is accompanied by asterisk (\*) is the CTO model.

• この部品表は、機種共通の部品と、機種によって使い分けが必要な部品に分かれています。  
• 機種名に(\*)がつくのはCTOモデルです。

△ [MA]  
△ [MA]

**Confidential**

PCG-GRT99/GRT77/GRT55 (J)  
PCG-GRT170/GRT150/GRT25F/GRT160 (AM)  
PCG-GRT716S/GRT796HP/GRT715E/  
PCG-GRT795MP/GRT715M/GRT796SP (EU)  
PCG-GRT30P/GRT25/GRT30LP/GRT30CP/GRT25CP (AO)

**L-4. 15-inch XGA (Clear Black)**  
**-Made by HI-**

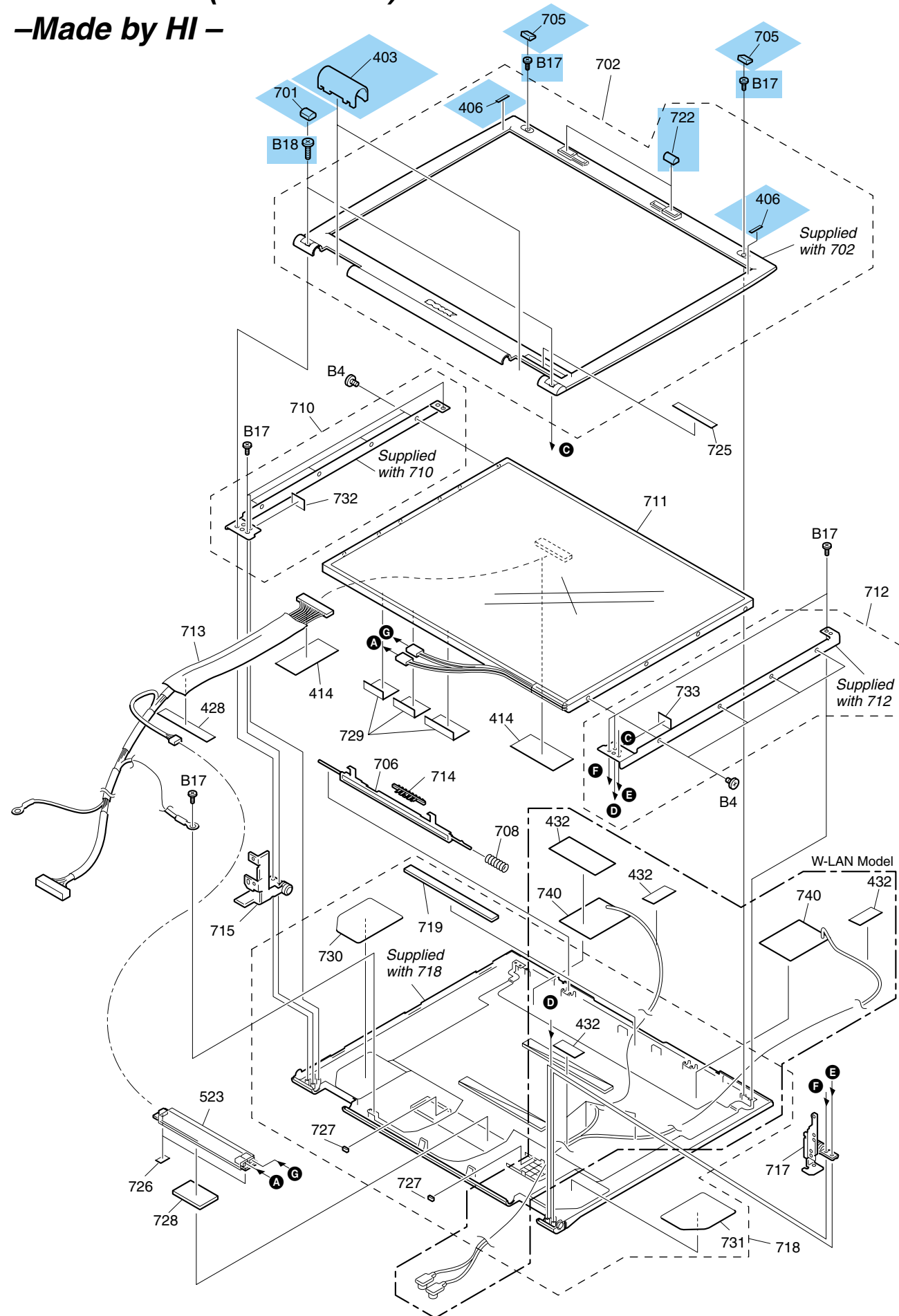

Ref.No.	Part No.	Description
403	4-667-073-11	& COVER HINGE
406	4-672-201-11	& CUSHION BEZEL
414	4-677-679-01	FOIL LCD HARNESS
428	4-672-403-01	COPPER TAPE LCD ED
523	1-478-040-11	INVERTER UNIT
701	4-672-197-11	& COVER SCREW LOWER
702	A-8115-900-A	ASSY HOUSING BEZEL 15 HIT
705	4-672-198-11	& COVER SCREW UPPER
706	4-673-710-01	LATCH HONTAI
708	4-672-199-01	SPRING (LATCH), COMPRESSION
710	X-4626-189-1	ASSY BRACKET LCD L HIT
711	A-8115-792-A	\$ # ASSY LCD 15XGA(HI)(S)
712	X-4626-190-1	ASSY BRACKET LCD R HIT
713	9-885-031-25	LCD HARNESS
714	4-670-668-11	LATCH BUTTON
715	4-673-807-01	HINGE L
717	4-673-808-01	HINGE R
718	A-8115-897-A	ASSY DISPLAY HOUSING 15 (SBR)(S)
719	4-676-424-01	SHEET DISPLAY HOUSING HIT
722	4-672-202-11	& CUSHION LATCH
726	4-676-478-01	SHEET DISPLAY HOUSING HIT 2
727	4-676-479-01	SHEET DISPLAY HOUSING HIT 3
728	4-676-422-01	SHEET PLATE LCD
729	4-676-480-01	FOIL LCD HIT
730	4-677-670-01	SHEET PLATE LCD L
731	4-677-669-01	SHEET PLATE LCD R
732	4-676-481-01	SHEET BRACKET LCD L HIT
733	4-676-482-01	SHEET BRACKET LCD R HIT
B4	4-641-726-81	SCREW (M2), SPECIAL HEAD
B17	4-641-726-61	& SCREW (M2), SPECIAL HEAD
B18	4-664-453-21	& SCREW (M2X7), SPECIAL HEAD

△ [MA]

Ref.No.	Part No.	Description	J	AM	
			GRT55/B	GRT100 *	GRT160
432		FILAMENT TAPE		●	●
725	4-676-187-51	LABEL ID	●		
	4-676-187-62	LABEL ID			●
740	1-754-295-21	ANTENNA, FILM (L AND R)		●	●

△ [MA]

- This parts list contains two different types of parts.  
 The first type is the parts that are common to all models.  
 The other type is the parts that are different depending on each model.
- The model that is accompanied by asterisk (\*) is the CTO model.

- この部品表は、機種共通の部品と、機種によって使い分けが必要な部品に分かれています。
- 機種名に(\*)がつくのはCTOモデルです。

**Confidential**

PCG-GRT99/GRT77/GRT55 (J)  
 PCG-GRT170/GRT150/GRT25F/GRT160 (AM)  
 PCG-GRT716S/GRT796HP/GRT715E/  
 PCG-GRT795MP/GRT715M/GRT796SP (EU)  
 PCG-GRT30P/GRT25/GRT30LP/GRT30CP/GRT25CP (AO)

**L-5. 15-inch SXGA, XGA  
(Normal, High Brightness)  
-Made by SH-**

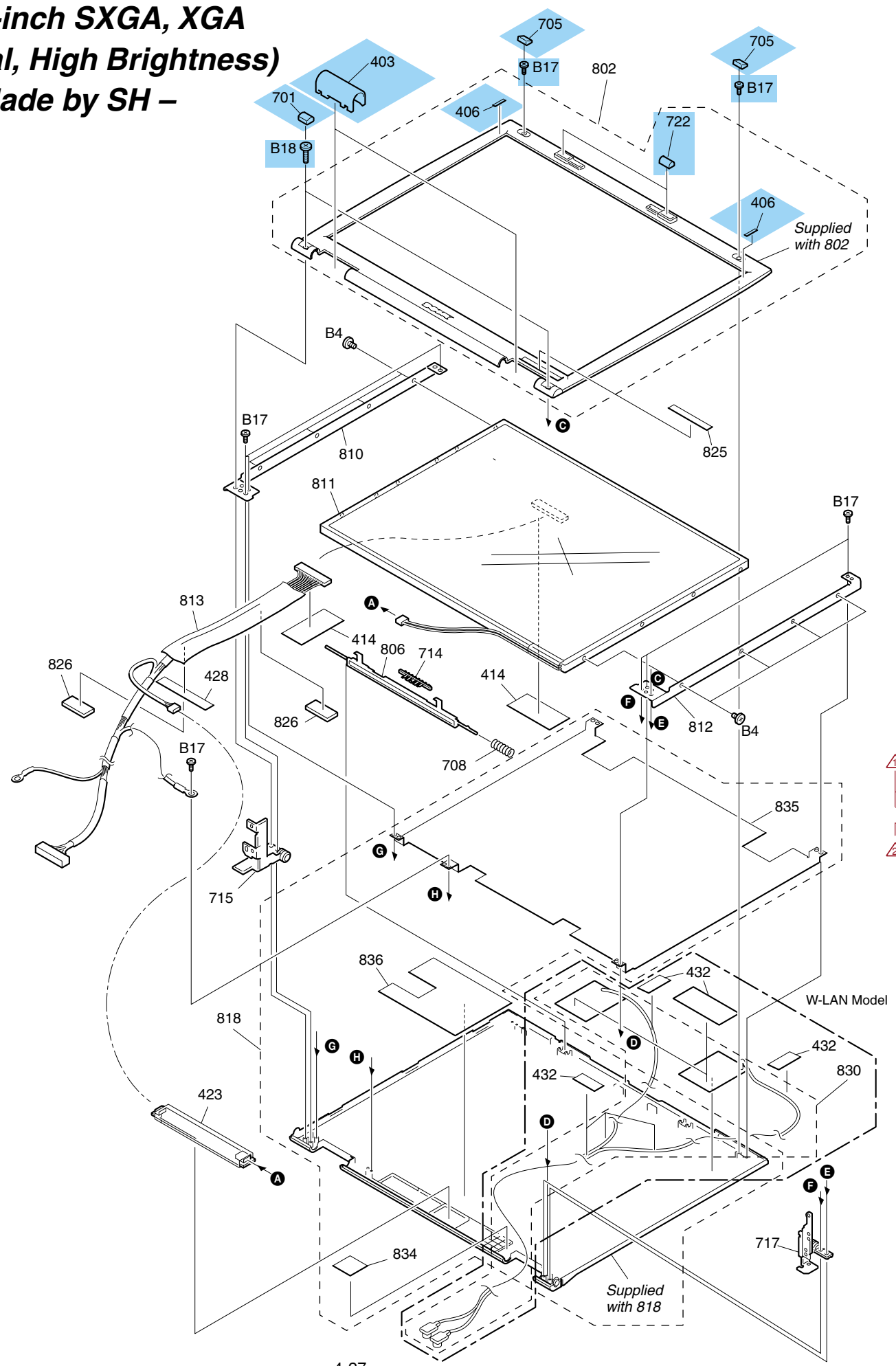

Ref.No.	Part No.	Description
403	4-667-073-11	& COVER HINGE
406	4-672-201-11	& CUSHION BEZEL
414	4-677-679-01	FOIL LCD HARNESS
423	1-476-316-31	INVERTER UNIT
428	4-672-403-01	COPPER TAPE LCD ED
701	4-672-197-11	& COVER SCREW LOWER
705	4-672-198-11	& COVER SCREW UPPER
708	4-672-199-01	SPRING (LATCH), COMPRESSION
714	4-670-668-11	LATCH BUTTON
715	4-673-807-01	HINGE L
717	4-673-808-01	HINGE R
722	4-672-202-11	& CUSHION LATCH
802	A-8115-899-A	ASSY HOUSING BEZEL 15(S)
806	4-670-669-11	LATCH HONTAI
* 810	4-671-115-01	BRACKET LCD 15 (L)
* 812	4-671-114-02	BRACKET LCD 15 (R)
818	A-8115-898-A	ASSY HOUSING DISPLAY 15(S)
826	4-677-683-01	DISPLAY GASKET
834	4-673-316-01	GT2 CUSHION WL CABLE
835	4-677-672-01	SHIELD DISPLAY
836	4-677-680-01	FOIL HOUSING DISPLAY
B4	4-641-726-81	SCREW (M2), SPECIAL HEAD
B17	4-641-726-61	& SCREW (M2), SPECIAL HEAD
B18	4-664-453-21	& SCREW (M2X7), SPECIAL HEAD

Ref.No.	Part No.	Description	J		AM		EU			AO				
			GRT750 *	GRT100 *	GRT25F	GRT15E	GRT15M	GRT795MP	GRT785B	GRT785E	GRT25	GRT25CP	GRT25L	
432		FILAMENT TAPE												
811	A-8115-790-A	\$ # ASSY LCD 15XGA(SH)(S)												
	A-8110-581-A	\$ # ASSY LCD 15SX(SH4)(S)												
	A-8113-853-A	\$ # ASSY LCD 15(SH)GT2(S)												
813	9-885-031-28	15XGA N/B HARNESS												
	9-885-031-26	LCD HARNESS SXGA+												
	9-885-031-27	15XGA N/B/L HARNESS												
825	4-676-191-31	LABEL ID												
	4-676-191-41	LABEL ID												
	4-676-191-51	LABEL ID												
	4-676-189-31	LABEL ID												
	4-676-188-41	LABEL ID												
	4-676-192-11	LABEL ID												
	4-676-188-51	LABEL ID												
	4-676-191-71	LABEL ID												
	4-676-191-81	LABEL ID												
830	1-754-295-21	ANTENNA, FILM (L AND R)												

△ [MA]  
△ [MA]  
△ [MA]

△ [MA]  
△ [MA]  
△ [MA]  
△ [MA]  
△ [MA]

- This parts list contains two different types of parts. The first type is the parts that are common to all models. The other type is the parts that are different depending on each model.
- The model that is accompanied by asterisk (\*) is the CTO model.

• この部品表は、機種共通の部品と、機種によって使い分けが必要な部品に分かれています。  
• 機種名に(\*)がつくのはCTOモデルです。

**Confidential**

PCG-GRT99/GRT77/GRT55 (J)  
PCG-GRT170/GRT150/GRT25F/GRT160 (AM)  
PCG-GRT716S/GRT796HP/GRT715E/  
PCG-GRT795MP/GRT715M/GRT796SP (EU)  
PCG-GRT30P/GRT25/GRT30LP/GRT30CP/GRT25CP (AO)

**L-6. 14-inch XGA**  
**-Made by HI-**

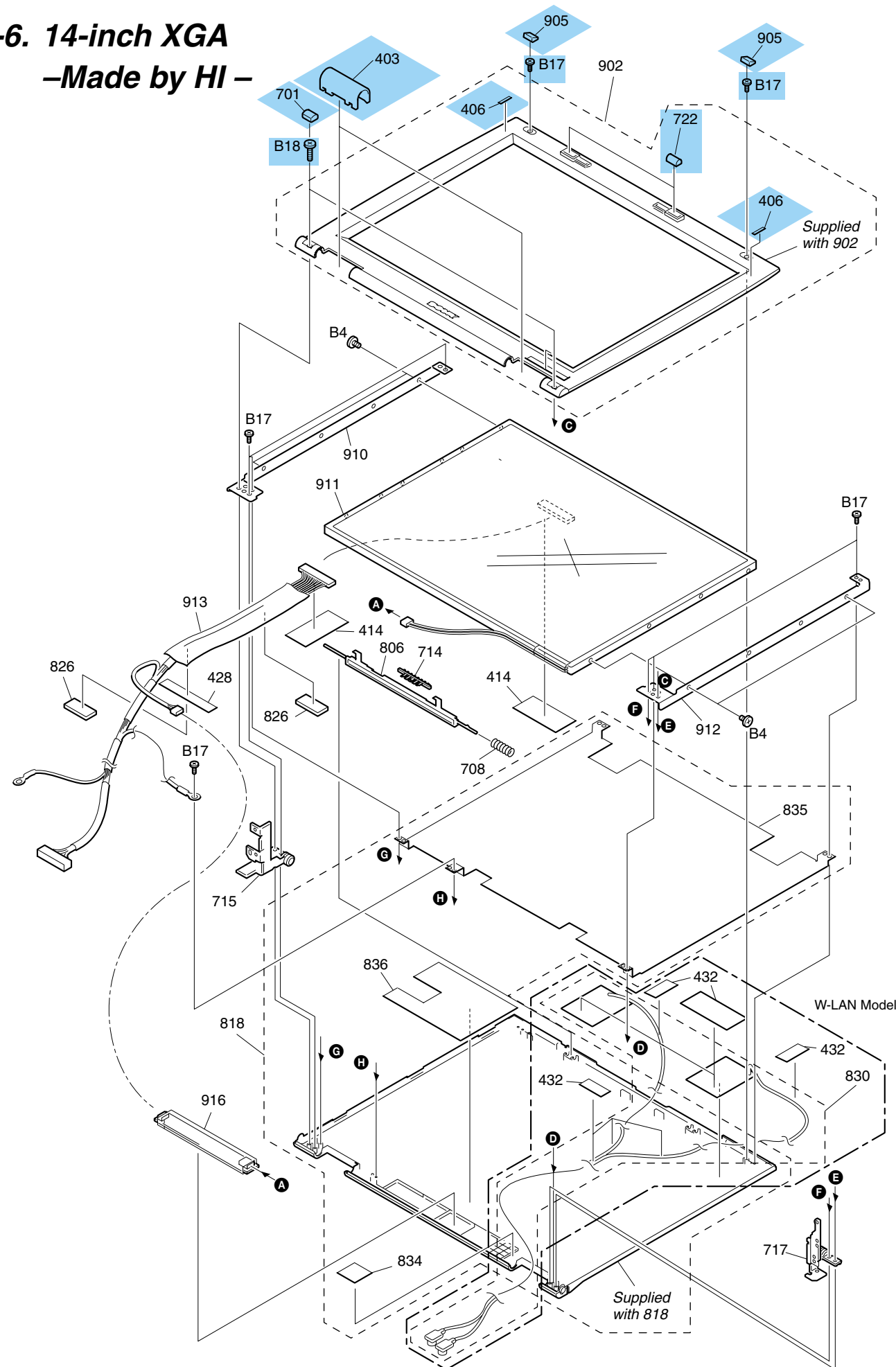

Ref.No.	Part No.	Description
403	4-667-073-11	& COVER HINGE
406	4-672-201-11	& CUSHION BEZEL
418	4-677-679-01	FOIL LCD HARNESS
428	4-672-403-01	COPPER TAPE LCD ED
432		FILAMENT TAPE
701	4-672-197-11	& COVER SCREW LOWER
708	4-672-199-01	SPRING (LATCH), COMPRESSION
714	4-670-668-11	LATCH BUTTON
715	4-673-807-01	HINGE L
717	4-673-808-01	HINGE R
722	4-672-202-11	& CUSHION LATCH
806	4-670-669-11	LATCH HONTAI
818	A-8115-898-A	ASSY HOUSING DISPLAY 15
826	4-677-683-01	DISPLAY GASKET
830	1-754-295-31	ANTENNA, FILM (L AND R)
834	4-673-316-01	GT2 CUSHION WL CABLE
835	4-677-672-01	SHIELD DISPLAY
836	4-677-680-01	FOIL HOUSING DISPLAY
902	A-8115-901-A	ASSY HOUSING BEZEL 14
905	4-672-203-11	& COVER SCREW UPPER 14
* 910	4-671-117-01	BRACKET LCD 14 (L)
911	A-8113-928-A	\$ # LCD UNIT(14.1XGA)(H)(S)
* 912	4-671-116-01	BRACKET LCD 14 (R)
913	9-885-031-28	15XGA N/B HARNESS
916	1-476-317-21	INVERTER UNIT
B4	4-641-726-81	SCREW (M2), SPECIAL HEAD
B17	4-641-726-61	& SCREW (M2), SPECIAL HEAD
B18	4-664-453-21	& SCREW (M2X7), SPECIAL HEAD



# DIP Switch

The DIP switch setting is following table.  
DIPスイッチの設定は下の表をご参照ください

J	PCG-GRT99/P 	PCG-GRT77/B 	PCG-GRT55/B 
AM	PCG-GRT170 	PCG-GRT150 	<b>△[MA]</b> PCG-GRT25F 
	<b>△[MA]</b> PCG-GRT160 		
EU	PCG-GRT796SP 	PCG-GRT716S 	PCG-GRT796HP 
	PCG-GRT715E, GRT795MP 	<b>△[MA]</b> PCG-GRT715M, GRT785E 	<b>△[MA]</b> PCG-GRT786M 
	<b>△[MA]</b> PCG-GRT785B 		
AO	<b>△[MA]</b> PCG-GRT30P 	<b>△[MA]</b> PCG-GRT25 	<b>△[MA]</b> PCG-GRT30LP 
	<b>△[MA]</b> PCG-GRT30CP 	<b>△[MA]</b> PCG-GRT25L 	<b>△[MA]</b> PCG-GRT25CP 

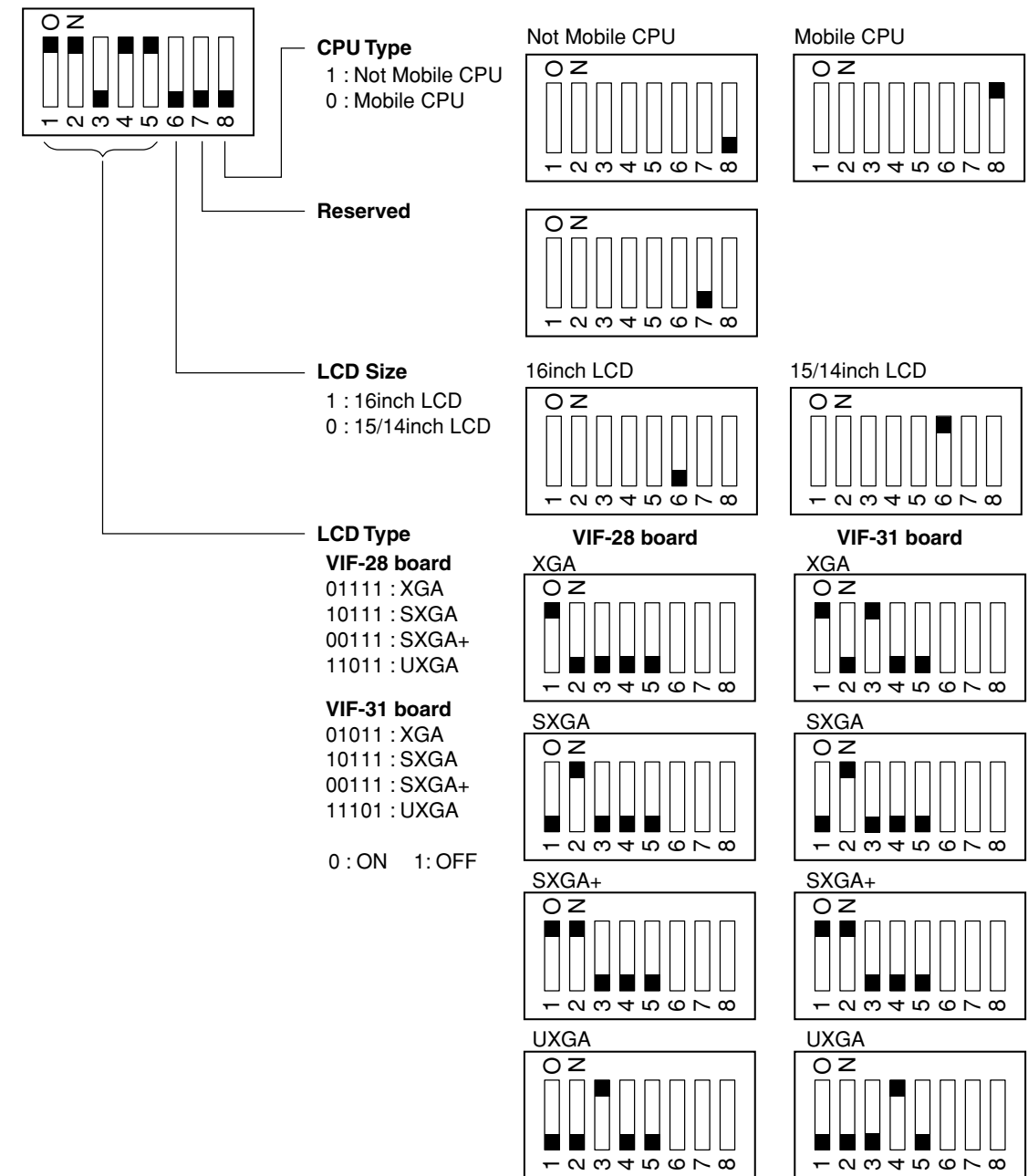

The DIP switch setting is different depending the types of LCD, CPU and VIF board.  
Set the DIP switch of the CTO model in accordance with the above table.  
For the method of identifying the types of the VIF board, see the illustration shown below.

DIPスイッチの設定は、LCDやCPU、VIF基板の種類により異なります。  
CTOモデルは、上の表に従ってDIPスイッチを設定してください。  
VIF基板の見分け方については、下記の図をご覧ください。

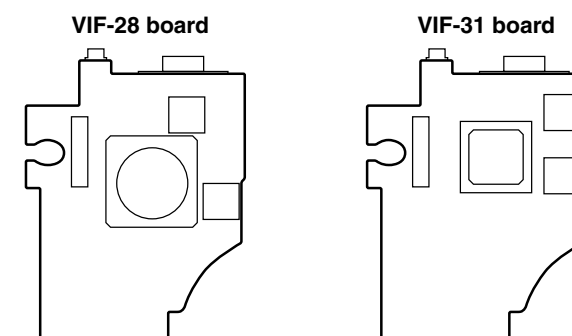

**Confidential**

PCG-GRT99/GRT77/GRT55 (J)  
PCG-GRT170/GRT150/GRT25F/GRT160 (AM)  
PCG-GRT716S/GRT796HP/GRT715E/  
PCG-GRT795MP/GRT715M/GRT796SP (EU)  
PCG-GRT30P/GRT25/GRT30LP/GRT30CP/GRT25CP (AO)

### 5-1. バーコードラベルについて

#### バーコードラベルの見方

バーコードラベルの網掛け部分は、修理データとして使用いたします。

#### 5-1. The barcode label

The hatched portion of the barcode label is used as the repair data.

[ MBX-86 Board ] (Side A)

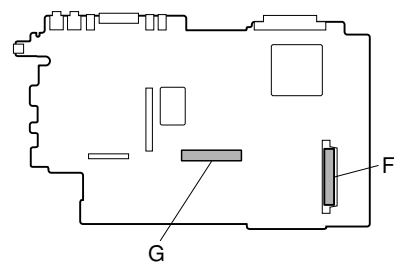

[ HDD ] (Made by I) (Top)

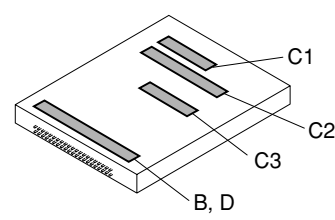

[ DVD+-RW Drive ] (Made by So) (Top)

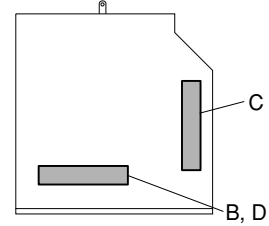

[ MBX-86 Board ] (Side B)

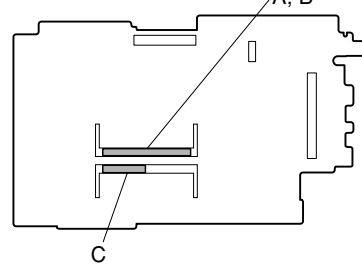

[ HDD ] (Made by Hi) (Top)

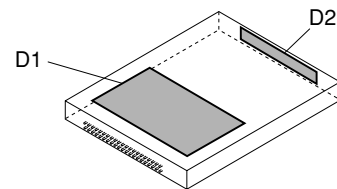

[ DVD-RW Drive ] (Made by To) (Top)

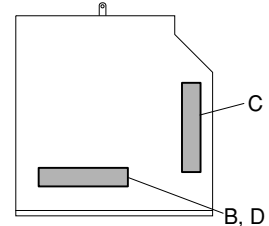

[ Wireless LAN Card ]

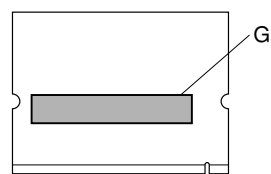

[ HDD ] (Made by Fu) (Top)

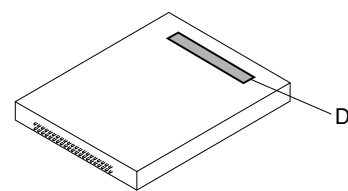

[ DVD-RW Drive ] (Made by Pa) (Top)

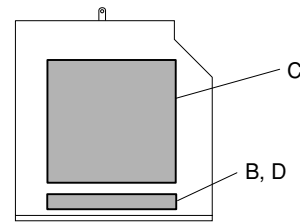

[ Modem Card ]

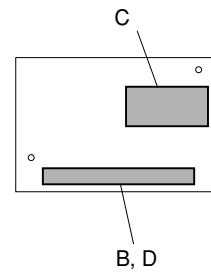

[ Combination Drive ] (Made by Pa) (Top)

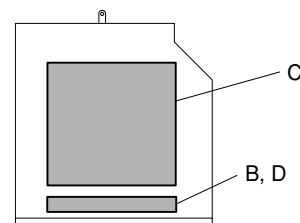

[ LCD Unit (16-inch UXGA Clear Black) (HI) ] (Rear)

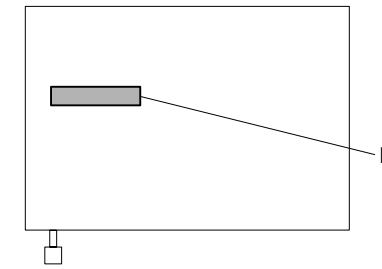

[ LCD Unit (15-inch XGA) (SH) ] (Rear)

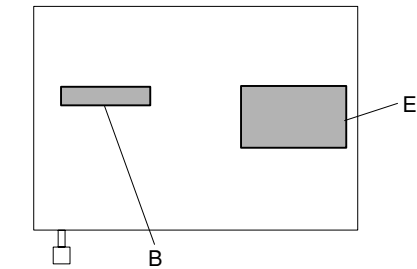

[ LCD Unit (16-inch SXGA Clear Black) (HI) ] (Rear)

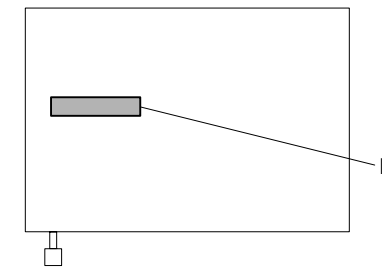

[ LCD Unit (15-inch SXGA) (SH) ] (Rear)

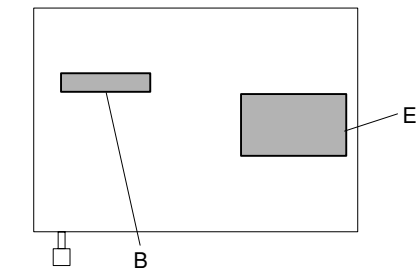

[ LCD Unit (16-inch SXGA+) (HI) ] (Rear)

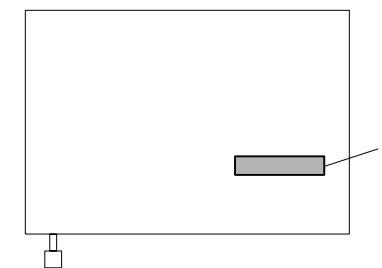

[ LCD Unit (15-inch XGA Clear Black) (HI) ] (Rear)

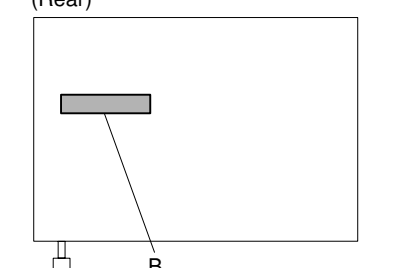

[ LCD Unit (16-inch SXGA+) (HI) ] (Rear)

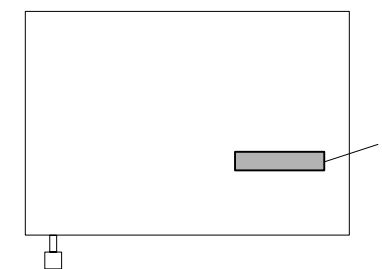

[ LCD Unit (14-inch XGA) (HI) ] (Rear)

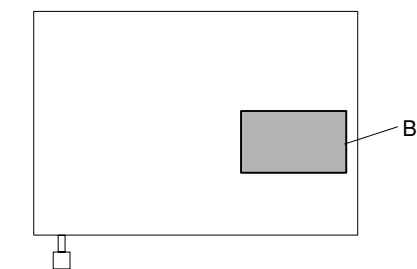

[ LCD Unit (16-inch SXGA) (SH) ] (Rear)

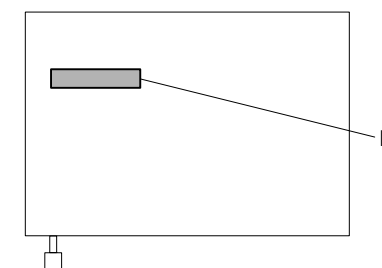

- A : Parts No.
- B : Serial No.
- C : Revision No.
- D : Product code
- E : Maker Barcode
- F : Global User ID (iLink)
- G : Mac Address
- [ Hatched Area ] : Barcode



## 5-2. Replacing the CPU

### 1. Removing the CPU

- ① Insert a flat-blade screwdriver into the notch as shown in the illustration and rotate it so that the protrusion comes to the lock release position.
- ② Pull the CPU gently upward to lift it out of the CPU socket.

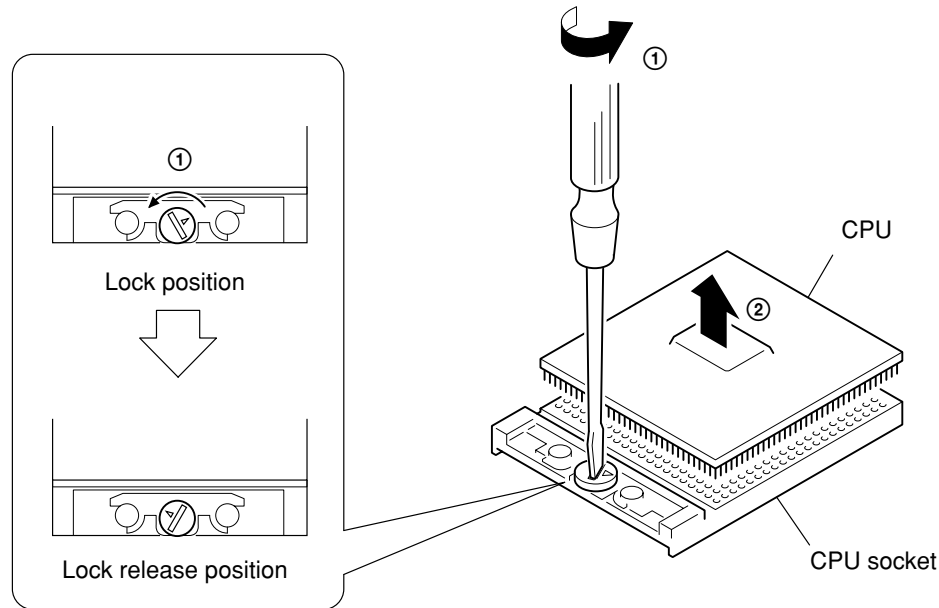

### 2. Installing the CPU

- ① Align the triangle reference mark of the CPU with that of the CPU socket and insert all the pins of the CPU to the corresponding holes of the CPU socket.
- ② Insert a flat-blade screwdriver into the notch as shown in the illustration and rotate it so that the protrusion comes to the lock position.

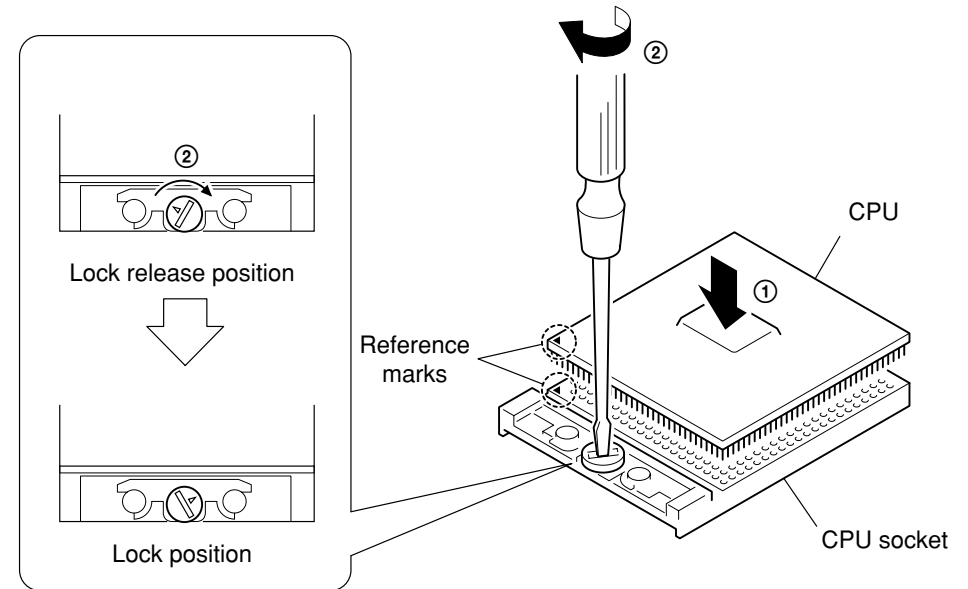

#### NOTE:

Rotate a flat-blade screwdriver to the lock position securely. If not, the operation of the CPU may become unstable.

**Confidential**

PCG-GRT99/GRT77/GRT55 (J)  
PCG-GRT170/GRT150/GRT25F/GRT160 (AM)  
PCG-GRT716S/GRT796HP/GRT715E/GRT795MP/GRT715M/  
PCG-GRT796SP/GRT786M/GRT785B/GRT785E (EU)  
PCG-GRT30P/GRT25/GRT30LP/GRT30CP/GRT25CP/GRT25L (AO)

## 5-3. CTO Information

### 1. PCG-GRT770

Model name : PCG-GRT770P (Japanese Area)

Model number : PCG-8M2Q

OS:WindowsXP Pro

Ver.1.0

LCD	16.1 UXGA(Clear Black) A-8115-722-A LCD UNIT(16TFT-UXGA-HI)(S)	16.1 UXGA A-8059-922-A ASSY LCD 168(HI)(S)	16.1 SXGA+(Clear Black) A-8115-721-A LCD UNIT(16TFT-SXGA+-HI)(S)	16.1 SXGA+ A-8067-707-A ASSY LCD 16SXGA(HI)(S)
CPU	P4-2.8GHz 6-704-133-01 IC RK80532PE072512SL6S4	P4-2.40B GHz 6-704-128-01 IC RK80532PE056512SL6RZ	Cel-1.8GHz 6-703-826-01 IC RH80532NC033256	
Memory	512MB(512MBx1) A-8067-880-A COMPLETE PWB MM-10	256MB(256MBx1) 6-704-094-01 IC MT8VDDT3264HDG-265C3		
HDD	80GB A-8067-943-A ASSY HDD 80GB(I,40)(S)	60GB A-8111-360-A ASSY HDD 60GB(T,30)(S)	40GB A-8113-859-A ASSY HDD 40GB(H)(S)	
Optical	DVD+-RW 8-457-509-00 DVD DRIVE,DW-U50A-VN			
Gigapo	○	×		
Battery	PCGA-BP2NX A-8067-763-A BP2NX SNT(J)ASSY(S)			

Model name : PCG-GRT770 (Japanese Area)

Model number : PCG-8M2Q

OS:WindowsXP Home

Ver.1.0

LCD	16.1 UXGA(Clear Black) A-8115-722-A LCD UNIT(16TFT-UXGA-HI)(S)	16.1 UXGA A-8059-922-A ASSY LCD 168(HI)(S)	16.1 SXGA+(Clear Black) A-8115-721-A LCD UNIT(16TFT-SXGA+-HI)(S)	16.1 SXGA+ A-8067-707-A ASSY LCD 16SXGA(HI)(S)
CPU	P4-2.8GHz 6-704-133-01 IC RK80532PE072512SL6S4	P4-2.40B GHz 6-704-128-01 IC RK80532PE056512SL6RZ	Cel-1.8GHz 6-703-826-01 IC RH80532NC033256	
Memory	512MB(512MBx1) A-8067-880-A COMPLETE PWB MM-10	256MB(256MBx1) 6-704-094-01 IC MT8VDDT3264HDG-265C3		
HDD	80GB A-8067-943-A ASSY HDD 80GB(I,40)(S)	60GB A-8111-360-A ASSY HDD 60GB(T,30)(S)	40GB A-8113-859-A ASSY HDD 40GB(H)(S)	
Optical	DVD+-RW 8-457-509-00 DVD DRIVE,DW-U50A-VN			
Gigapo	○	×		
Battery	PCGA-BP2NX A-8067-763-A BP2NX SNT(J)ASSY(S)			

**Confidential**

PCG-GRT99/GRT77/GRT55 (J)  
PCG-GRT170/GRT150/GRT25F/GRT160 (AM)  
PCG-GRT716S/GRT796HP/GRT715E/GRT795MP/GRT715M/  
PCG-GRT796SP/GRT786M/GRT785B/GRT785E (EU)  
PCG-GRT30P/GRT25/GRT30LP/GRT30CP/GRT25CP/GRT25L (AO)

2. PCG-GRT750

**Model name : PCG-GRT750P (Japanese Area)**  
**Model number : PCG-8M2Q**

OS:WindowsXP Pro  
 Ver.1.0

<b>LCD</b>	<b>15 XGA(Clear Black)</b> A-8115-792-A ASSY LCD 15XGA(HI)(S)	<b>15 XGA</b> A-8115-790-A ASSY LCD 15XGA(SH)(S)	
<b>CPU</b>	<b>P4-2.8GHz</b> 6-704-133-01 IC RK80532PE072512SL6S4	<b>P4-2.40B GHz</b> 6-704-128-01 IC RK80532PE056512SL6RZ	<b>MCel-1.8GHz</b> 6-703-826-01 IC RH80532NC033256
<b>Memory</b>	<b>512MB(512MBx1)</b> A-8067-880-A COMPLETE PWB MM-10	<b>256MB(256MBx1)</b> 6-600-158-01 IC HYS64D32020GDL-7-B	
<b>HDD</b>	<b>80GB</b> A-8067-943-A ASSY HDD 80GB(I,40)(S)	<b>60GB</b> A-8111-360-A ASSY HDD 60GB(T,30)(S)	<b>40GB</b> A-8113-859-A ASSY HDD 40GB(H)(S)
<b>Optical</b>	<b>DVD+-RW</b> 8-457-509-00 DVD DRIVE,DW-U50A-VN	<b>CD-RW/DVD-ROM</b> 1-796-594-11 COMBO DRIVE(UJDA740)	
<b>Gigapo</b>	○	×	
<b>Battery</b>	<b>PCGA-BP2NX</b> A-8067-763-A BP2NX SNT(J)ASSY(S)		

**Model name : PCG-GRT750 (Japanese Area)**  
**Model number : PCG-8M2Q**

OS:WindowsXP Home  
 Ver.1.0

<b>LCD</b>	<b>15 XGA(Clear Black)</b> A-8115-792-A ASSY LCD 15XGA(HI)(S)	<b>15 XGA</b> A-8115-790-A ASSY LCD 15XGA(SH)(S)	
<b>CPU</b>	<b>P4-2.8GHz</b> 6-704-133-01 IC RK80532PE072512SL6S4	<b>P4-2.40B GHz</b> 6-704-128-01 IC RK80532PE056512SL6RZ	<b>MCel-1.8GHz</b> 6-703-826-01 IC RH80532NC033256
<b>Memory</b>	<b>512MB(512MBx1)</b> A-8067-880-A COMPLETE PWB MM-10	<b>256MB(256MBx1)</b> 6-600-158-01 IC HYS64D32020GDL-7-B	
<b>HDD</b>	<b>80GB</b> A-8067-943-A ASSY HDD 80GB(I,40)(S)	<b>60GB</b> A-8111-360-A ASSY HDD 60GB(T,30)(S)	<b>40GB</b> A-8113-859-A ASSY HDD 40GB(H)(S)
<b>Optical</b>	<b>DVD+-RW</b> 8-457-509-00 DVD DRIVE,DW-U50A-VN	<b>CD-RW/DVD-ROM</b> 1-796-594-11 COMBO DRIVE(UJDA740)	
<b>Gigapo</b>	○	×	
<b>Battery</b>	<b>PCGA-BP2NX</b> A-8067-763-A BP2NX SNT(J)ASSY(S)		

**Confidential**

PCG-GRT99/GRT77/GRT55 (J)  
 PCG-GRT170/GRT150/GRT25F/GRT160 (AM)  
 PCG-GRT716S/GRT796HP/GRT715E/GRT795MP/GRT715M/  
 PCG-GRT796SP/GRT786M/GRT785B/GRT785E (EU)  
 PCG-GRT30P/GRT25/GRT30LP/GRT30CP/GRT25CP/GRT25L (AO)

### 3. PCG-GRT100

Model name : PCG-GRT100P (American Area)  
 Model number : PCG-8M1R (With W-LAN), PCG-8M2R (W/O W-LAN)

OS:WindowsXP Pro  
 Ver.1.0

<b>LCD</b>	<b>16.1 UXGA(Clear Black)</b> A-8115-722-A LCD UNIT(16TFT-UXGA-HI)(S)	<b>16.0 SXGA</b> A-8112-385-A ASSY LCD SXGA 16(S)	<b>15.0 SXGA+</b> A-8110-581-A ASSY LCD 15SX(SH4)(S)	<b>15.0 XGA(High Brightness)</b> A-8115-790-A ASSY LCD 15XGA(SH)(S)	<b>14.1 XGA</b> A-8113-928-A LCD UNIT(14.1XGA)(H)(S)			
<b>CPU</b>	<b>P4-M2.5GHz</b> 6-704-320-01 IC RH80532GC060512	<b>P4-M2.2GHz</b> 6-703-846-01 IC RH80532GC049512	<b>P4-M2.0GHz</b> 6-703-333-01 IC RH80532GC041512-2	<b>P4-2.8GHz</b> 6-704-133-01 IC RK80532PE072512SL6S4	<b>P4-2.66GHz</b> 6-704-132-01 IC RK80532PE067512SL6S3	<b>P4-2.40B GHz</b> 6-704-128-01 IC RK80532PE056512SL6RZ	<b>MICP-1800</b> 6-703-826-01 IC RH80532NC033256	
<b>Memory</b>	<b>1024MB(512MBx2)</b> A-8067-880-A COMPLETE PWB MM-10	<b>512MB(512MBx1)</b> A-8067-880-A COMPLETE PWB MM-10	<b>512MB(256MBx2)</b> 6-704-094-01 IC MT8VDDT3264HDG-265C3	<b>256MB(256MBx1)</b> 6-704-094-01 IC MT8VDDT3264HDG-265C3				
<b>HDD</b>	<b>80GB</b> A-8067-943-A ASSY HDD 80GB(I,40)(S)	<b>60GB</b> A-8111-360-A ASSY HDD 60GB(T,30)(S)	<b>40GB</b> A-8113-859-A ASSY HDD 40GB(H)(S)	<b>30GB</b> A-8113-860-A ASSY HDD 30GB(H)(S)				
<b>Optical</b>	<b>DVD+-RW</b> 8-457-509-00 DVD DRIVE,DW-U50A-VN	<b>DVD-RW</b> 1-796-506-11 W-DVD(SD-R6012)	<b>CD-RW/DVD-ROM</b> 1-796-594-11 COMBO DRIVE(UJDA740)					
<b>Battery</b>	<b>PCGA-BP2NX</b> A-8112-427-A BP2NX SNT(U)ASSY(S)							

Model name : PCG-GRT100 (American Area)  
 Model number : PCG-8M1R (With W-LAN), PCG-8M2R (W/O W-LAN)

OS:WindowsXP Home  
 Ver.1.0

<b>LCD</b>	<b>16.1 UXGA(Clear Black)</b> A-8115-722-A LCD UNIT(16TFT-UXGA-HI)(S)	<b>16.0 SXGA</b> A-8112-385-A ASSY LCD SXGA 16(S)	<b>15.0 SXGA+</b> A-8110-581-A ASSY LCD 15SX(SH4)(S)	<b>15.0 XGA(High Brightness)</b> A-8115-790-A ASSY LCD 15XGA(SH)(S)	<b>14.1 XGA</b> A-8113-928-A LCD UNIT(14.1XGA)(H)(S)			
<b>CPU</b>	<b>P4-M2.5GHz</b> 6-704-320-01 IC RH80532GC060512	<b>P4-M2.2GHz</b> 6-703-846-01 IC RH80532GC049512	<b>P4-M2.0GHz</b> 6-703-333-01 IC RH80532GC041512-2	<b>P4-2.8GHz</b> 6-704-133-01 IC RK80532PE072512SL6S4	<b>P4-2.66GHz</b> 6-704-132-01 IC RK80532PE067512SL6S3	<b>P4-2.40B GHz</b> 6-704-128-01 IC RK80532PE056512SL6RZ	<b>MICP-1800</b> 6-703-826-01 IC RH80532NC033256	
<b>Memory</b>	<b>1024MB(512MBx2)</b> A-8067-880-A COMPLETE PWB MM-10	<b>512MB(512MBx1)</b> A-8067-880-A COMPLETE PWB MM-10	<b>512MB(256MBx2)</b> 6-704-094-01 IC MT8VDDT3264HDG-265C3	<b>256MB(256MBx1)</b> 6-704-094-01 IC MT8VDDT3264HDG-265C3				
<b>HDD</b>	<b>80GB</b> A-8067-943-A ASSY HDD 80GB(I,40)(S)	<b>60GB</b> A-8111-360-A ASSY HDD 60GB(T,30)(S)	<b>40GB</b> A-8113-859-A ASSY HDD 40GB(H)(S)	<b>30GB</b> A-8113-860-A ASSY HDD 30GB(H)(S)				
<b>Optical</b>	<b>DVD+-RW</b> 8-457-509-00 DVD DRIVE,DW-U50A-VN	<b>DVD-RW</b> 1-796-506-11 W-DVD(SD-R6012)	<b>CD-RW/DVD-ROM</b> 1-796-594-11 COMBO DRIVE(UJDA740)					
<b>Battery</b>	<b>PCGA-BP2NX</b> A-8112-427-A BP2NX SNT(U)ASSY(S)							

Model name : PCG-GRT100K (American Area)  
 Model number : PCG-8M1R (With W-LAN), PCG-8M2R (W/O W-LAN)

OS:Windows2000  
 Ver.1.0

<b>LCD</b>	<b>16.1 UXGA(Clear Black)</b> A-8115-722-A LCD UNIT(16TFT-UXGA-HI)(S)	<b>16.0 SXGA</b> A-8112-385-A ASSY LCD SXGA 16(S)	<b>15.0 SXGA+</b> A-8110-581-A ASSY LCD 15SX(SH4)(S)	<b>15.0 XGA(High Brightness)</b> A-8115-790-A ASSY LCD 15XGA(SH)(S)	<b>14.1 XGA</b> A-8113-928-A LCD UNIT(14.1XGA)(H)(S)			
<b>CPU</b>	<b>P4-M2.5GHz</b> 6-704-320-01 IC RH80532GC060512	<b>P4-M2.2GHz</b> 6-703-846-01 IC RH80532GC049512	<b>P4-M2.0GHz</b> 6-703-333-01 IC RH80532GC041512-2	<b>P4-2.8GHz</b> 6-704-133-01 IC RK80532PE072512SL6S4	<b>P4-2.66GHz</b> 6-704-132-01 IC RK80532PE067512SL6S3	<b>P4-2.40B GHz</b> 6-704-128-01 IC RK80532PE056512SL6RZ	<b>MICP-1800</b> 6-703-826-01 IC RH80532NC033256	
<b>Memory</b>	<b>1024MB(512MBx2)</b> A-8067-880-A COMPLETE PWB MM-10	<b>512MB(512MBx1)</b> A-8067-880-A COMPLETE PWB MM-10	<b>512MB(256MBx2)</b> 6-704-094-01 IC MT8VDDT3264HDG-265C3	<b>256MB(256MBx1)</b> 6-704-094-01 IC MT8VDDT3264HDG-265C3				
<b>HDD</b>	<b>80GB</b> A-8067-943-A ASSY HDD 80GB(I,40)(S)	<b>60GB</b> A-8111-360-A ASSY HDD 60GB(T,30)(S)	<b>40GB</b> A-8113-859-A ASSY HDD 40GB(H)(S)	<b>30GB</b> A-8113-860-A ASSY HDD 30GB(H)(S)				
<b>Optical</b>	<b>DVD+-RW</b> 8-457-509-00 DVD DRIVE,DW-U50A-VN	<b>DVD-RW</b> 1-796-506-11 W-DVD(SD-R6012)	<b>CD-RW/DVD-ROM</b> 1-796-594-11 COMBO DRIVE(UJDA740)					
<b>Battery</b>	<b>PCGA-BP2NX</b> A-8112-427-A BP2NX SNT(U)ASSY(S)							

**Confidential**

PCG-GRT99/GRT77/GRT55 (J)  
 PCG-GRT170/GRT150/GRT25F/GRT160 (AM)  
 PCG-GRT716S/GRT796HP/GRT715E/GRT795MP/GRT715M/  
 PCG-GRT796SP/GRT786M/GRT785B/GRT785E (EU)  
 PCG-GRT30P/GRT25/GRT30LP/GRT30CP/GRT25CP/GRT25L (AO)



PCG-GRT99/GRT77/GRT55 (J)

PCG-GRT170/GRT150/GRT25F/GRT160 (AM)

PCG-GRT716S/GRT796HP/GRT715E/GRT795MP/GRT715M/GRT796SP/GRT786M/GRT785B/GRT785E (EU)

PCG-GRT30P/GRT25/GRT30LP/GRT30CP/GRT25CP/GRT25L (AO)

### List of PCG-GRT Series (As of August, 2003)

Model Name	Service Manual Part No.
PCG-GRT99/P	9-876-309-04
PCG-GRT77/B	
PCG-GRT55/B	
PCG-GRT170	
PCG-GRT150	
PCG-GRT716S	
PCG-GRT796HP	
PCG-GRT715E	
PCG-GRT795MP	
PCG-GRT715M	
PCG-GRT25F	
PCG-GRT796SP	
PCG-GRT30P	
PCG-GRT25	
PCG-GRT160	
PCG-GRT30LP	
PCG-GRT30CP	
PCG-GRT25CP	
PCG-GRT786M	
PCG-GRT785B	
PCG-GRT785E	
PCG-GRT25L	

This manual and the constituent data may not be replicated, copied nor reprinted in whole or in part without prior written authorization of Sony Corporation.

## Revision History

Suffix	Ver.	Date	Contents	QM No.
-01	Ver. 1	2003.06.09	First Edition	
-02	Ver. 2	2003.06.18	△1 Front Page (Model Line Up), Page1-1, Page 1-2, Page 4-1 - 4-18, Page 4-23, Page 4-24 Page 4-27, Page 4-28, Page 4-31 - 4-34, Page 5-1, Page 5-2, Back Cover	N2003_035AK
-03	Ver. 3	2003.07.17	△2 Front Page (Model Line Up), Page1-1 - 1-2, Page 4-1 - 4-18, Page 4-23 - 4-28 Page 4-31 - 4-33, Back Cover	N2003_042AK
-04	Ver. 4	2003.08.07	△3 Front Page (Model Line Up), Page1-1 - 1-2, Page 4-1 - 4-18, Page 4-21 - 4-22 Page 4-27 - 4-28, Page 4-31 - 4-33, Back Cover	N2003_049AK
< Remarks >				

[Confidential]

PCG-GRT99/GRT77/GRT55 (J)

PCG-GRT170/GRT150/GRT25F/GRT160 (AM)

PCG-GRT716S/GRT796HP/GRT715E/GRT795MP/GRT715M/GRT796SP/GRT786M/GRT785B/GRT785E (EU)

PCG-GRT30P/GRT25/GRT30LP/GRT30CP/GRT25CP/GRT25L (AO)