

Fellowes

PAPER SHREDDER
Personal Series

DESTRUCTEUR DE DOCUMENTS
Série usage personnel

DESTRUCTORA DE DOCUMENTOS
Serie de uso personal



MODELS / MODÈLES / MODELOS
S70-2, P700-2, S50-2, P500-2, P500-2W

USE AND CARE MANUAL

MANUEL D'EMPLOI ET D'ENTRETIEN

MODO DE EMPLEO Y DE CUIDADO

PLEASE READ AND SAVE THIS MANUAL WITH YOUR ORIGINAL RECEIPT
Customer Service: 1-800-955-0959

VEUILLEZ LIRE CE MANUEL ET LE CONSERVER AVEC LE TALON D'ACHAT
Service clientèle (Canada) : 1-800-665-4339

POR FAVOR, LEA Y GUARDE ESTE MANUAL CON EL RECIBO ORIGINAL
Dpto. de Atención al Cliente: 1-800-955-0959

PRODUCT USAGE GUIDE

	S70-2, P700-2	S50-2, P500-2, P500-2W
Sheet capacity*:	11	8
Shred type:	Strip	Strip
Shred size:	1/4"	1/4"
Entry width:	9"	9"
Recommended use:	10-20 shredding passes per day	
Maximum running time:	5-7 min. on / 15 minutes off	

*Sheet capacity measured with 20 lb., 8-1/2" x 11" paper with the shredder operating at rated voltage.
Different paper weights, humidity, and electrical currents will affect capacity.

CARACTÉRISTIQUES

	S70-2, P700-2	S50-2, P500-2, P500-2W
Capacité de destruction (feuilles)* :	11	8
Type des déchets :	Bandes	Bandes
Dimension des déchets :	6,3 mm	6,3 mm
Largeur d'entrée :	230 mm	230 mm
Emploi recommandé :	10 à 20 passages de feuilles par jour	
Cycles d'utilisation conseillés :	5 à 7 minutes marche / 15 minutes arrêt	

*Capacité de destruction mesurée pour du papier 20 lb 8-1/2" x 11" (A4/70gsm), le destructeur fonctionnant sur tension nominale. Les différents grammages du papier, l'humidité et la tension affecteront la capacité.

CARACTERÍSTICAS

	S70-2, P700-2	S50-2, P500-2, P500-2W
Capacidad de destrucción (hojas)*:	11	8
Tipo de corte:	Tiras	Tiras
Dimensión de corte:	1/4" (6,3 mm)	1/4" (6,3 mm)
Ancho de entrada:	9" (230 mm)	9" (230 mm)
Uso recomendado:	de 10 a 20 pasadas diarias por la destructora	
Tiempo máx. de funcionamiento:	5-7 min. encendido / 15 min. apagado	

*La capacidad de destrucción se calculó con hojas de 20 lb. 8-1/2" x 11" (A4/70gsm), con la destructora funcionando al voltaje nominal. Cambiando el peso del papel, la humedad y el voltaje se afecta tal capacidad.

IMPORTANT SAFEGUARDS

WARNING

- NEVER insert hands or fingers into paper entry as serious personal injury may result.
- THIS MACHINE IS NOT A TOY. Keep children and pets away from shredder AT ALL TIMES as serious injury may result. Always unplug shredder when not in use.
- Keep loose objects (jewelry, ties, long hair) away from shredder. These items and others like them may cause serious injury if they accidentally fall into the paper entry.

CAUTION

- Do not exceed recommended sheet capacity.
- Do not shred plastic (except credit cards), continuous forms, adhesive labels, transparencies, newsprint, or cardboard.
- This personal shredder is intended for paper only. Do not attempt to shred paper clips or other hard materials (except staples).
- Do not place shredder near or over a heat source or water.
- Always turn off and unplug unit before moving or cleaning and when not in use.
- Do not insert aerosol cleaners or lubricants into or around the shredder. Some agents may combust, causing serious injury.
- Do not use this product if it or the cord has been damaged in any way.
- Do not open the cover for any reason. Doing so can expose you to dangerous voltages and will void your warranty.

Power Cord Care

- Place power cord in an easily accessible position, because it is the main disconnect switch.
- Do not place machine where adults, children or animals may walk on the cord.
- Do not rest anything on the power cord.
- If an extension cord is used, be sure that all products plugged into the extension cord do not exceed the extension cord ampere rating.

PARTS OF THE SHREDDER

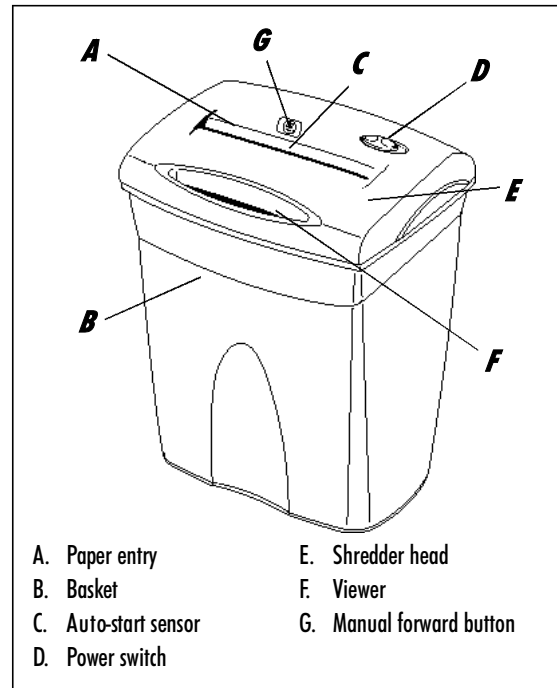

ASSEMBLY

To assemble shredder head onto basket

1. Position shredder head over basket as shown in Figure 1.
2. Lower shredder head onto basket aligning the rim on the underside of the shredder head with the edge of the basket.

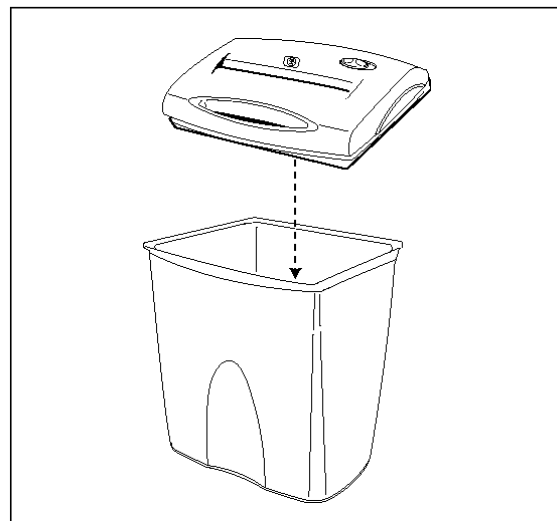

Figure 1

OPERATION



WARNING This product features an auto-start sensor. This sensor will turn on the cutting blades whenever anything is inserted into the paper entry (while the power switch is in the **AUTO (I)** position). For the safety of pets and children, we recommend always moving the power switch to **OFF (O)** and unplugging whenever the shredder is unattended or not in use.

1. Assemble shredder head to basket (see "ASSEMBLY").
2. Remove any paper clips or other foreign objects (except staples) from paper. If folding paper to fit paper entry, adjust sheet capacity appropriately.



CAUTION Do not attempt to shred paper clips or other hard materials (except staples) with this machine. Extensive use of paper clips or other hard materials will result in damage to the cutting system and will void the manufacturer's warranty.

3. Be sure power switch is in the **OFF (O)** position. Plug shredder into the proper power supply outlet.
4. Move power switch to **AUTO (I)** position. As soon as the unit is turned on, it is in autostart mode, ready to be fed paper through



WARNING the paper entry. NEVER insert hands or fingers into paper entry as serious personal injury may result.



CAUTION Do not exceed recommended sheet capacity (see "Product Usage Guide" on page 1).

5. Slide paper **straight** into paper entry until the shredder automatically begins shredding.

The shredder automatically stops when shredding is complete.

Continue shredding as desired to a **MAXIMUM shredding time of 5-7 minutes**. At this time, the machine **MUST** be allowed to "**cool down**" for a **MINIMUM of 15 minutes**. (See "Cool-Down Cycle" section for more information.)

If the shredder jams or shuts off before the maximum shredding time, see "Clearing a Jam" section for further instructions.

6. Move power switch to **OFF (O)** position when shredding is complete.
7. Unplug power cord from outlet when shredder is not in use.
8. Look through viewer to see if basket is full. If full, lift off shredder head and empty basket contents. Replace shredder head into position on basket.

Cool-Down Cycle

This shredder is protected with a special safety feature which prevents the motor from overheating with extensive use. ***When shredding is attempted beyond the machine's maximum running time, the shredder will automatically shut off its motor until it has cooled to an acceptable operating level.*** This is normal and the shredder will return to operation after the "cool-down" period. See "Product Usage Guide" (page 1) for maximum running time and related cooling or "off" time.



Clearing a Jam

If the shredder sheet capacity is exceeded or paper is not put in straight, a jam may result. See "Product Usage Guide" (page 1) for maximum sheet capacity for your shredder. In the case of a jam, the machine will "bog down" and fail to shred the paper.

To clear a jam:

1. Move the power switch to the **REVERSE (R)** position. (If waste basket is full, empty it before clearing jam.) The shredder will reverse the paper to clear the jam.
2. If the shredder jams in reverse, move the power switch to **AUTO (I)**, depress the manual forward button  and allow to run for about five seconds. If jam does not clear, move power switch to **REVERSE (R)** again and allow to run for about five seconds. Repeat this procedure until the jam is cleared. If necessary, use care to grasp the paper and pull out to clear the jam.
3. Once the jam is cleared, move the power switch to **AUTO (I)** for continued shredding or **OFF (O)** if shredding is complete.

TROUBLESHOOTING

Shredder will not operate.	<ul style="list-style-type: none"> a. Shredder is not plugged in. b. Power switch is in the OFF (O) position. Move switch to AUTO (I) position. c. Shredder is jammed. See "Clearing a Jam" section. d. Shredder has exceeded the maximum run time and requires a "cool-down" time. See "Product Usage Guide" (page 1).
Shredder suddenly stops while shredding.	<ul style="list-style-type: none"> a. Shredder has exceeded the maximum run time and requires a "cool-down" time. See "Product Usage Guide" (page 1). b. Shredder is jammed. See "Clearing a Jam" in the OPERATION section.
Shredder operates only in REVERSE.	A small piece of paper may be blocking the auto-start sensor of this shredder. Move the power switch to AUTO (I) and depress the manual forward button  for 5 seconds to clear paper blockage.
Shredder runs continuously when in AUTO.	<ul style="list-style-type: none"> a. Look through viewer to see if basket is full. If full, lift shredder head and empty basket contents. Replace shredder head into position on basket. b. A small piece of paper may be blocking the auto-start sensor of shredder. Move power switch to AUTO (I) and depress the manual forward button  for 5 seconds to clear paper blockage.

LIMITED WARRANTY

Fellowes Manufacturing Company (the "Company") warrants the cutting cylinders of the machine to be free from defects in material and workmanship for 3 years from the date of purchase by the original consumer. Fellowes warrants all other parts of the machine to be free of defects in material and workmanship for 1 year from the date of purchase by the original consumer. If any part is found to be defective during the warrant period, your sole and exclusive remedy will be repair or replacement, at Fellowes' option and expense, of the defective part.

This warranty does not apply in cases of abuse, mishandling or unauthorized repair. ANY IMPLIED WARRANTY, INCLUDING THAT OF MERCHANTABILITY OR FITNESS FOR A PARTICULAR PURPOSE, IS HEREBY LIMITED IN DURATION TO THE APPROPRIATE WARRANTY PERIOD SET FORTH ABOVE. In no event shall Fellowes be liable for any consequential or incidental damages attributable to this product. This warranty gives you specific legal rights. You may have other legal rights that vary from state to state.

For more detail or to obtain service under this warranty, please contact Fellowes Customer Service at 1-800-955-0959, Monday through Friday, 8 AM - 5 PM (Central Standard Time).

For specific instructions on obtaining service under this warranty on machines purchased outside the USA, contact the appropriate location listed in the **Contact for Service** section of this instruction manual.

Warrantor: Fellowes, Inc.

Fellowes conducts extensive testing to ensure that these shredders are capable of meeting all of the specifications listed in the Usage Guide. However, the actual sheet capacity is dependent on a number of factors including the type and weight of paper, the humidity, the voltage level of the power source, the temperature of the motor, and the care with which the operator feeds the paper. Safety agency testing is conducted to ensure that the shredder will operate to specifications even if the available voltage is 10% below or 6% above the rated voltage.

Model	Voltage	Hertz	Cut Size	Number of Sheets	Paper Size & Weight
P500-2	220-240VAC	50HZ	6.3mm	7	8.5x11 20 Lb.
P500-2	120V	60Hz	6.3mm	7	8.5x11 20 Lb.
P700-2	220-240VAC	50HZ	6.3mm	10	8.5x11 20 Lb.
P700-2	120V	60Hz	6.3mm	10	8.5x11 20 Lb.

**Contact For Service
Vos Contacts Fellowes
Sus Contactos Fellowes**

Australia	1-800-33-11-77
Canada	1-800-665-4339
Mexico	001-800-234-1185
United States	1-800-955-0959

www.fellowes.com

Fellowes 1788 Newwood Avenue, Ross, Illinois 60143-1095 638-969-1688 Customer Service 1-800-945-4545 <http://www.fellowes.com>

Australia Sydney, N.S.W.	Canada Markham, Ont.	France Paris, J-F	Germany Gulzow, Sax.	Italy Carrara, MI	Japan Tokyo	Korea Seoul	Poland Warsaw	Singapore Singapore	United Kingdom Derbyshire, S. Yorks.
-----------------------------	-------------------------	----------------------	-------------------------	----------------------	----------------	----------------	------------------	------------------------	-----------------------------------------