



OPERATING AND SERVICE MANUAL

MODEL 4815A
RF VECTOR IMPEDANCE METER

SERIALS PREFIXED 631

Copyright Hewlett-Packard Company 1966

Green Pond Road Rockaway, New Jersey, U. S. A.

Table 1-1. Specifications

FREQUENCY	RECORDER OUTPUTS
<p>Range: 500 kHz to 108 MHz in five bands: 500 kHz to 1.5 MHz, 1.5 to 4.5 MHz, 4.5 to 14 MHz, 14 to 35 MHz, 35 to 108 MHz.</p> <p>Accuracy: $\pm 2\%$ of reading, $\pm 1\%$ of reading at 1.592 and 15.92 MHz.</p> <p>RF monitor output: 150 mV minimum into 50 ohms.</p>	<p>Frequency: 0 to 1 volt from 0 to 1K ohm source, proportional to dial rotation.</p> <p>Impedance magnitude: 0 to 1 volt from 1K ohm source.</p> <p>Phase angle: 0 ± 0.9 volt from 1K ohm source.</p>
IMPEDANCE MAGNITUDE MEASUREMENT	ACCESSORIES FURNISHED:
<p>Range: 1 ohm to 100K ohms; full-scale ranges: 10, 30, 100, 300, 1K, 3K, 10K, 30K, 100K ohms.</p> <p>Accuracy: $\pm 4\%$ of full scale $\pm \left(\frac{f}{30 \text{ MHz}} + \frac{Z}{25 \text{ K}\Omega} \right) \%$ of reading, where f = frequency in MHz and Z in ohms; reading includes probe residual impedance.</p> <p>Calibration: linear meter scale with increments 2% of full scale.</p>	<ol style="list-style-type: none"> 00600A Accessory Kit. Rack Mounting Kit. Plugin board extender.
PHASE ANGLE MEASUREMENT	DIMENSIONS:
<p>Range: 0 to 360° in two ranges: $0 \pm 90^\circ$, $180^\circ \pm 90^\circ$.</p> <p>Accuracy: $\pm \left(3 + \frac{f}{30 \text{ MHz}} + \frac{Z}{25 \text{ K}\Omega} \right)$ degrees; where f = frequency in MHz and Z is in ohms.</p> <p>Calibration: increments of 2°.</p> <p>Adjustments: front panel screwdriver adjustments for Magnitude and Phase Zero.</p>	<p>NOTES: (A) DIMENSIONS IN INCHES AND (MILLIMETERS). (B) REAR APRON RECESS. (C) DETACHABLE POWER CABLE. (D) RECOMMENDED CABLE CLEARANCE.</p>
	<p>WEIGHT: net 39 lbs. (17,6 kg), shipping 50 lbs. (22,5 kg).</p> <p>POWER: 105 to 125 v or 210 to 250 v, 50 to 400 Hz, 50 w.</p>

Table 1-2. Additional Information

MEASURING TERMINAL CHARACTERISTICS	RFI CHARACTERISTICS
<p>Configuration: Both excitation and measuring circuits are contained in a single sampling probe attached to instrument by a cable. Measurement is made between probe center pin and ground pin on probe case.</p> <p>Residuals: indicated impedance includes approximately 0.5 ohm resistance and 8 nH inductance in series with the unknown, and 0.3 pF capacitance in parallel with the unknown.</p> <p>Impedance: 25 ohms in series with 0.01 μF, looking into probe. Probe is constant-current driving source to circuit being measured.</p>	<p>External oscillator input: Rear BNC connector accepts excitation signal, 100 mV $\pm 10\%$ into 50 ohms; maximum instantaneous rate of change 1 MHz/s.</p>
TEST SIGNAL CHARACTERISTICS	SELF-CONTAINED CALIBRATION
<p>Waveshape: sinusoidal.</p> <p>Level: approximately 4 μA on all ranges except 10-ohm scale where it is approximately 13 μA.</p>	<p>Probe check: 100 ohms $\pm 5\%$ at phase angle of $0^\circ \pm 2^\circ$.</p>

SECTION I

GENERAL INFORMATION

1-1. DESCRIPTION.

1-2. The Model 4815A RF Vector Impedance Meter (Figure 1-1) is a general purpose, self-contained instrument for measuring complex impedance in a wide variety of laboratory applications as well as production testing of circuits and components. The frequency range is 0.5 to 108 MHz; impedance magnitude is measured in 9 ranges from 10 Ω to 100 K Ω full scale; and phase angle between 0 $^\circ$ and 360 $^\circ$ is indicated on two ranges.

1-3. Impedance measurement is made at the tip of a probe that is at the end of a 5 ft. cable, with rf test signal and measuring circuits brought close to the probe tip to reduce residual impedances.

1-4. An internal rf oscillator, 0.5 to 108 MHz supplies a test signal to the unknown impedance, 12.6 μ a on the 10 ohm range and 4 μ a on all other ranges. Provision is made for using an external rf source, particularly useful when measuring quartz crystals and other high Q devices.

1-5. Dc voltages proportional to magnitude, phase and frequency are available at the rear panel for recording equipment.

1-6. Complete specifications are given in Table 1-1.

1-7. Additional information on the Model 4815A is given in Table 1-2. The characteristics are general design parameters that are useful in the application of the Impedance Meter.

1-8. ACCESSORIES FURNISHED.

1-9. Accessory kit number 00600A is supplied with the 4815A. The kit consists of adapters for probe to BNC and Type N connectors, a probe socket for use on circuit boards, a component mounting adapter, probe holder, probe ground assembly and center pins. The probe accessories are described in detail in Paragraphs 1-9 to 1-16 and shown in Figure 1-1 and 1-2. Also supplied is a rack mounting kit with hardware (-hp- Stock No. 5060-0776) and a circuit board extender for servicing.

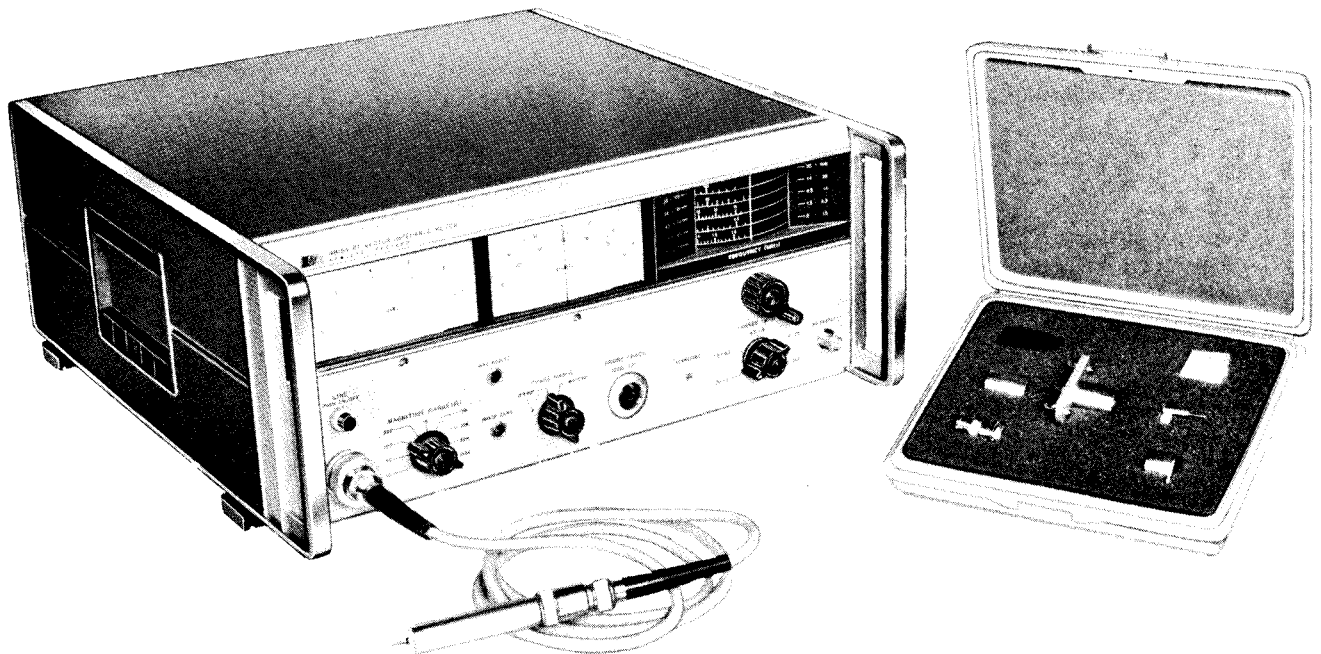

Figure 1-1. Model 4815A RF Vector Impedance Meter with 00600A Probe Accessory Kit

Paragraphs 1-10 to 1-21

1-10. **PROBE ADAPTER.** This adapter converts the probe tip to a male type N connector and is available under accessory number 10206A.

1-11. **PROBE TO BNC ADAPTER.** With the use of the 10206A accessory, this adapter converts the probe tip to a male BNC connector and is available under accessory number 10207A.

1-12. **PROBE SOCKET.** This socket supports the probe and guides the center pin to the test point. An excellent ground return is obtained with the socket, which is available under accessory number 10210A.

1-13. **COMPONENT MOUNTING ADAPTER.** This adapter allows many types of components to be measured with minimum addition of residual impedance to affect measurements, and is separately available as accessory number 00601A.

1-14. **PROBE GROUND ASSEMBLY** is a grounding device that may be positioned at a convenient point on the probe barrel. A spring-loaded pin makes ground contact. This accessory is available as -hp- Stock No. 187B-21A-8.

1-15. **PROBE CENTER PINS.** Six additional center pins are supplied against possible damage or loss. The small-diameter end of the center pin is inserted into the mating jack in the probe tip.

1-16. **PROBE HOLDER.** This accessory clips onto the front handle of the 4815A to hold the probe when not in use, and is available separately as -hp- Stock No. 5040-0404

1-17. ACCESSORIES AVAILABLE.

1-18. **SHIELDED BANANA PLUGS TO FEMALE BNC.** This adapter converts banana post inputs to shielded BNC, and is available as accessory 10111A. The adapter has approximately 10 pF shunt capacity.

1-19. INSTRUMENT IDENTIFICATION.

1-20. Each Model 4815A is identified by an eight-digit (000-00000) serial number on the rear panel. The five digit number is an identification number unique to each instrument and the three digit number is a serial prefix number used to document changes.

1-21. All instruments with the same serial prefix are the same. The group of instruments to which this manual applies directly is identified on the title page. For instruments with serial numbers higher than those listed on the title page, a Manual Change sheet describing the changes is included with the manual. The manual for an instrument having special electrical modifications will include an insert sheet describing that modification. If a change sheet or special information sheet is missing, the information can be supplied by any Hewlett-Packard Sales and Service Office listed at the back of this manual.

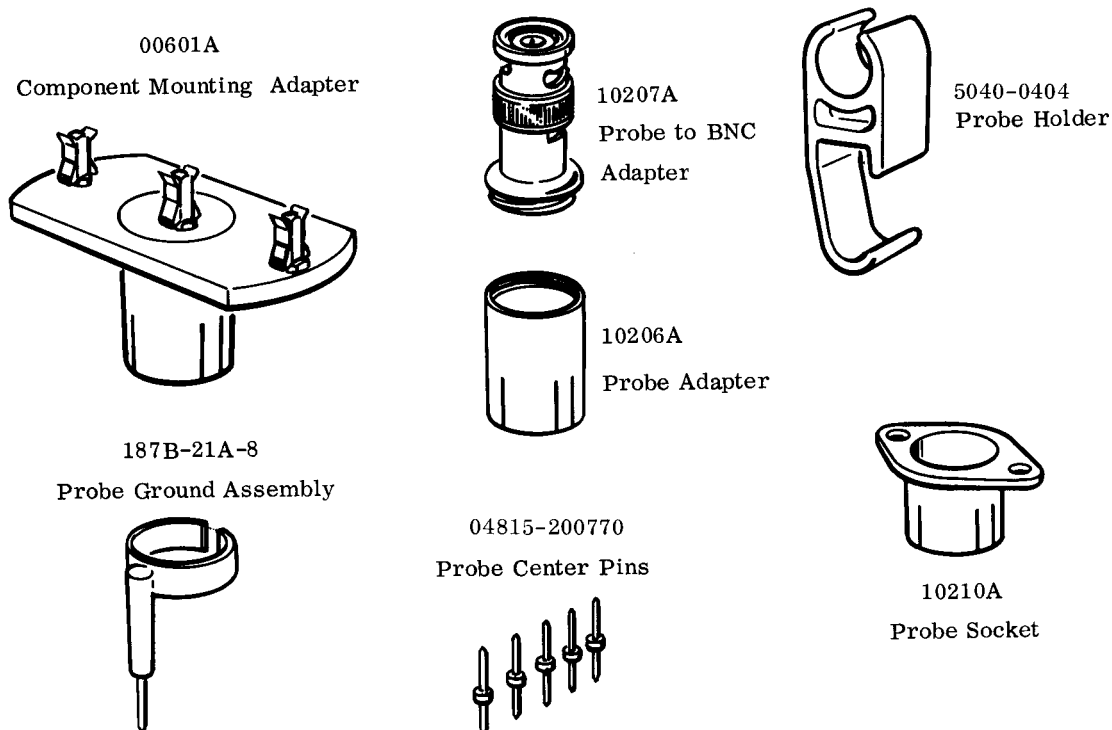

Figure 1-2. Probe Accessories

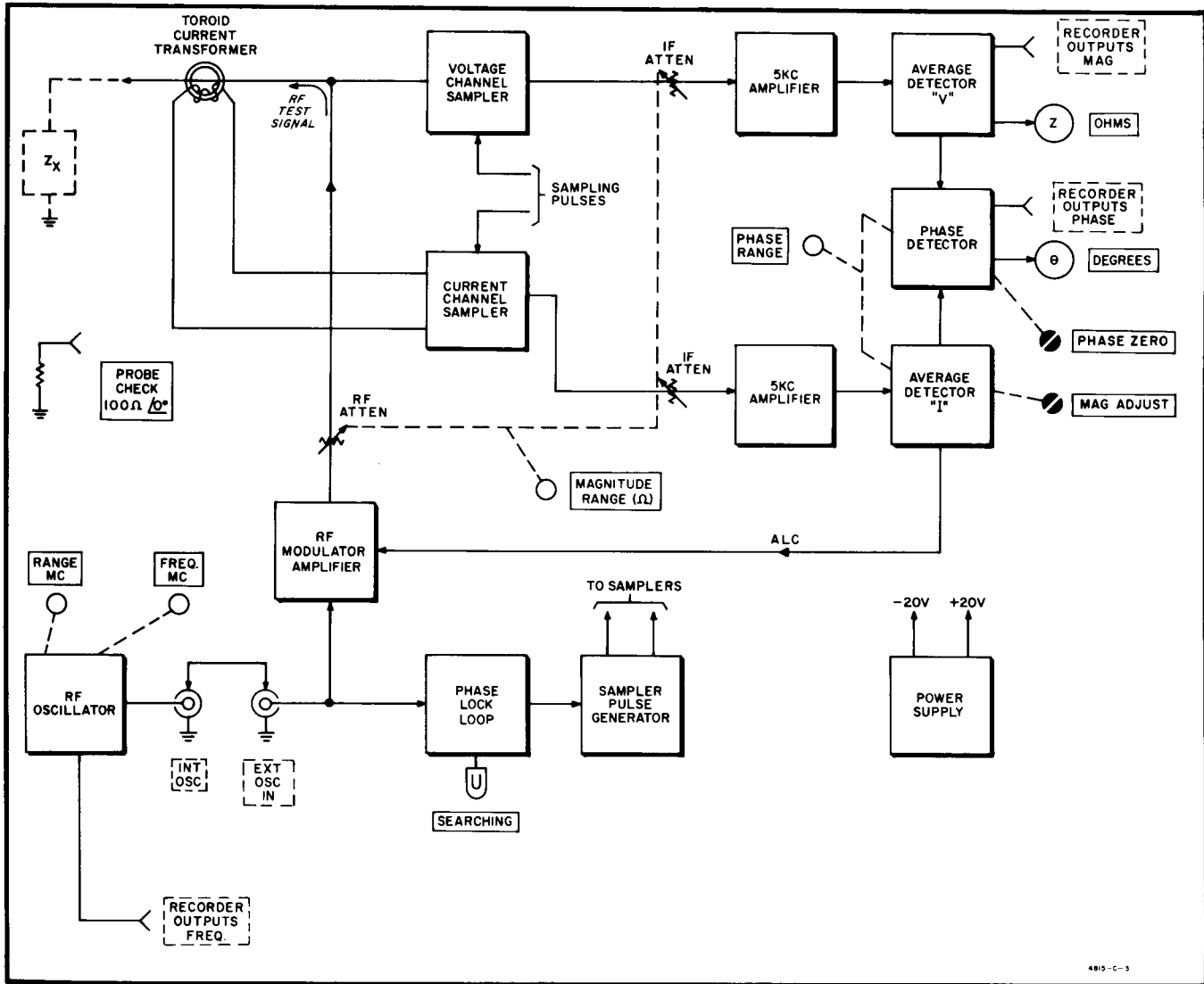
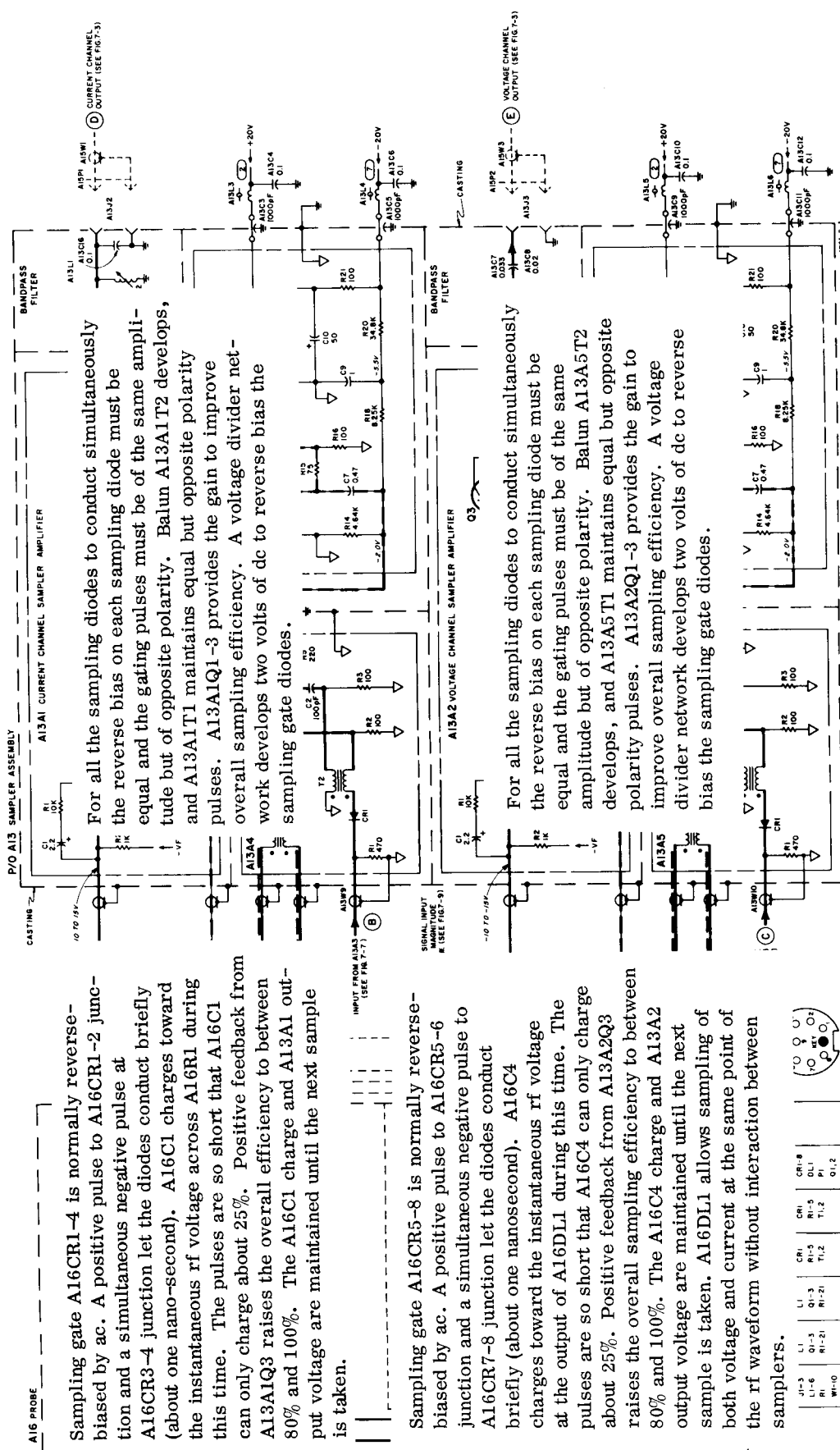
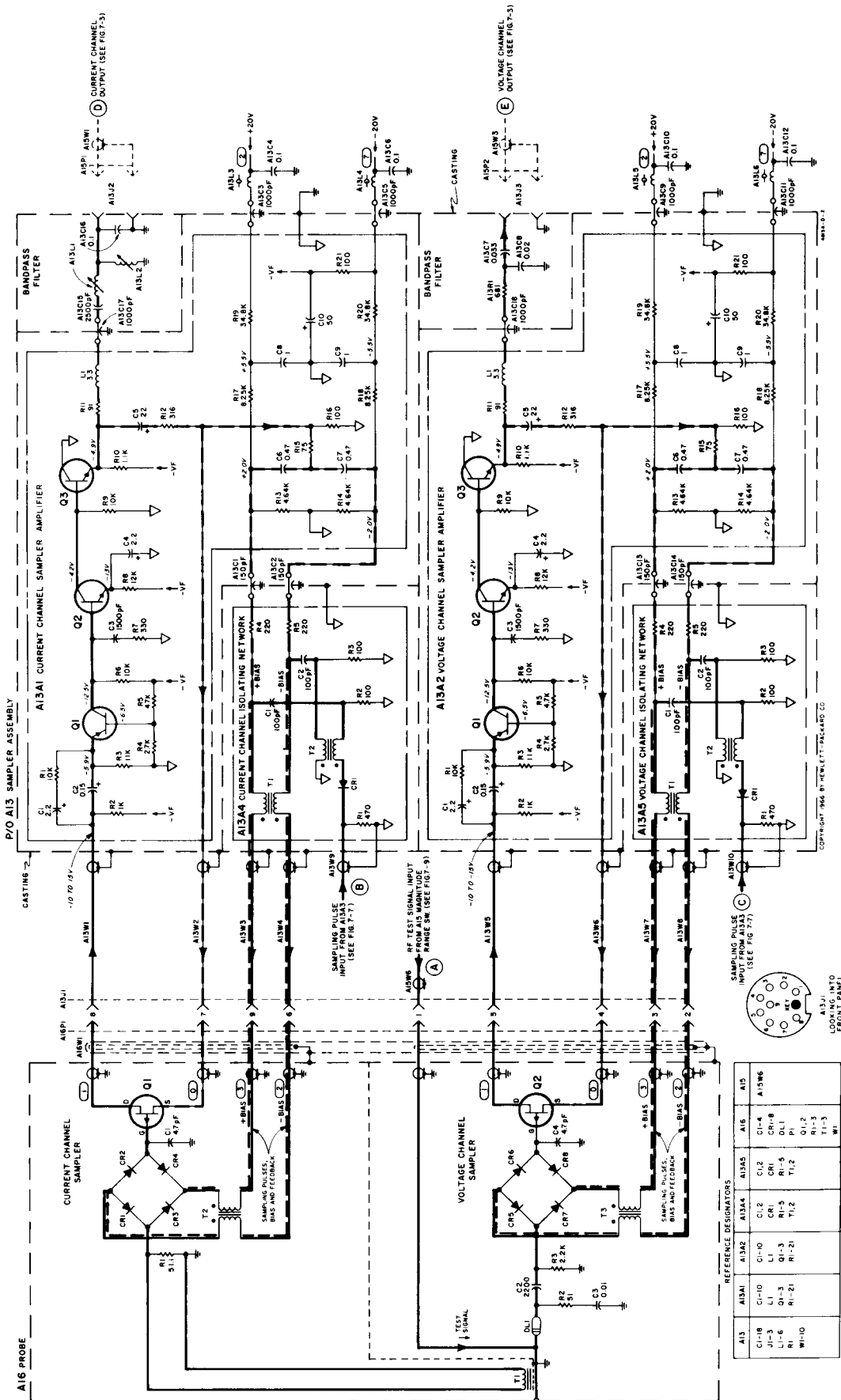

Figure 4-1. Simplified Overall Block Diagram.



4815A - PROBE & SAMPLER AMPS



4815A - PROBE & SAMPLER AMPS

Figure 4-3. Probe and Sampler Circuits (sheet 2 of 2)