

PLINIUS

SA - 103
POWER AMPLIFIER

INSTRUCTION MANUAL



CONGRATULATIONS on your decision to become the proud owner of this
Plinius SA-103 Power Amplifier.

This manual has been prepared to help you understand the operation of your amplifier, and to provide information about its design and the variety of ways it may be used.

We have designed and manufactured this amplifier to reproduce faithfully and accurately, your favourite music. With a little care and a full understanding of the operating recommendations in this manual, your Plinius SA-103 Power Amplifier will provide years of high-quality, trouble-free performance.

Serial Number:

Final Test Certified By:

IMPORTANT: PLEASE TAKE THE TIME TO READ THIS MANUAL
THOROUGHLY BEFORE USING YOUR AMPLIFIER.

DESIGN PHILOSOPHY

From a distance you can see that the design of the Plinius products is more than an applied styling exercise to the front panel. We have started from the ground up to produce a casing for our electronics that is unrivalled in its physical strength and visual simplicity. Wherever possible we have reduced the number of parts needed and then invested massively in refining and producing the remaining parts to the highest quality achievable with state of the art computer controlled machines allied with expert craftsman. Examples of this approach include the hydraulically formed corners on the amplifiers giving much greater strength and the one piece housing for the remote control unit that eliminates large joints and potential creaks.

The very process of holding the remote tells you that you are controlling both a powerful and precise product. It is designed specifically for the act of listening to music, not channel surfing on a television or changing the room temperature. The distinction is important because we believe that listening to music is a highly selective and emotional experience that requires a much greater level of concentration and precision to fully appreciate and enjoy.

As with music that you are not familiar with, truly innovative new designs can take time to understand and enjoy. How often have you heard music that you were first unsure of, that over repeated listening, has become a firm favourite. Our designs are fundamentally different to many other companies, and we hope that you will take the time to explore their unique character and qualities because we have not made them different simply to be different. We genuinely believe that their visual and tactile qualities do improve the experience of listening to music and that is our design goal!

Ross Stevens
Design Director.

A handwritten signature in black ink that reads "ROSS.S". Below the signature is a thick, horizontal blue underline.

CONTENTS

Introduction	Page 3
Precautions	Page 5
Amplifier Features - FRONT PANEL	Page 6
Amplifier Features - REAR PANEL	Page 8
Amplifier Configuration Selector (ACS)	Page 9
Balanced/Unbalanced Signals	Page 10
Installation and Operation	Page 12
Input/Output Connection	Page 13
RCA Connection	Page 14
XLR Connection	Page 15
SA-103 Features	Page 17
Loudspeaker Selection	Page 19
Why Class A is better	Page 20
Specifications	Page 21
Index	Page 22
Contact Details	Page 23

PRECAUTIONS

Please take special note of the following precautions before operating your new amplifier:

- The Plinius SA-103 Power Amplifier can be operated in mono mode delivering up to 460 watts into 8 ohms. This amplifier is also capable of a very large peak current delivery.
- The Plinius SA-103 Power Amplifier operates in Class A. It is capable of generating temperatures that could have an adverse effect on other equipment, furniture etc. DO NOT leave flammable material on the amplifier whilst running, as this could pose a serious fire risk.
- The Plinius SA-103 Power Amplifier is of direct-coupled design, and offers no protection from preamplifiers that have a high DC component at their outputs.
- This amplifier operates at hazardous voltage levels. Any work requiring removal of the lid or base of this amplifier must be referred to a suitably qualified and experienced service technician.
- DO NOT attempt to connect any input of this amplifier to it's own outputs.
- DO NOT earth any output terminal or connect any of these terminals together without following the instructions in this manual or seeking qualified assistance.
- DO NOT place this amplifier in any position where liquids or any foreign material may accidentally enter it.
- DO NOT connect any voltage source, short circuit, earth/ground or appliance (other than suitable high fidelity loudspeakers) to the amplifier output terminals.
- Some preamplifiers, processors, CD players' etc. produce large switching pulses when switched on causing a loud click through the loudspeakers. For this reason, turn on all other equipment in your system before turning on your Plinius SA-103, or ensure that the amplifier is in MUTE. You will not experience this phenomenon with Plinius Preamplifiers.

AMPLIFIER FEATURES – FRONT PANEL



FRONT PANEL LAYOUT SHOWING MUTE AND BIAS SWITCHES

MUTE SWITCH

It is not recommended practice to interfere with the input cables while the amplifier is switched on and connected to the loudspeakers, so a Mute button is fitted to interrupt the input signal. This allows you to connect and disconnect the input cables without the necessity of turning the amplifier off.

When the amplifier powers up from start, the Mute automatically closes and has to be switched for normal listening. Press the button once to open the mute, and again to close it. The mute also disconnects the speakers while the LED is on.

CLASS A SWITCH

This switch on the right of the panel alters the operating bias of the amplifier. Press once to activate Class A, and again for Class AB. In Class A the LED is ON. Either mode may be used for listening, with Class A preferred.

CLASS AB: This position reduces the bias on the output stage to operate the amplifier in Class AB. This is a bias configuration used by the majority of high fidelity amplifiers. In Class AB your Plinius SA-103 produces very high quality sound, suitable for all occasions where 'super critical' listening is not a priority. The quality of performance in this mode may exceed that of many other amplifiers so a dual benefit exists in that this facility provides the user with a much cooler operating temperature, and a much reduced demand on electricity particularly at idle (while the amplifier is not reproducing music). This unique feature allows you to leave the Plinius SA-103 switched ON at all times, rendering the amplifier ready for use and requiring only a few minutes of warm-up in Class A before the very best of the amplifier's sonic qualities may be experienced.

CLASS A: This position provides Class A bias to the output stage therefore ensuring the optimum performance of the amplifier during all listening events. Class A amplifiers run hotter than Class AB amplifiers, hence our specially designed and distinctive heat sinks. Operating the amplifier in Class A necessitates two precautions that should be observed.

1. On switching to Class A, the temperature of the amplifier will quickly increase and the amplifier will become quite hot. Once again we remind you to ensure that you have left adequate space around the amplifier for ventilation. Ensure that no objects are resting on the amplifier and check that the heat sink (cooling fins) are not obstructed in any way.
2. The power required from the mains supply in Class A is approximately 500 watts, similar to a small electric heater. The amplifier should not be connected to a wall outlet that is shared with other heavy current appliances such as heaters or electric motors. If in doubt, check with your Plinius dealer for advice.

AMPLIFIER FEATURES – REAR PANEL

This panel incorporates all the terminals for connecting the input signals from your preamplifier, and output to the loudspeakers, and mains supply. A reasonable understanding of this amplifier's operation and a logical approach should ensure that you are able to make all connections with ease.

Please remember that your Plinius SA-103 Power Amplifier is a high quality electronic instrument capable of an exceptional level of performance. Be sure that you understand your system's requirements fully before you make any connection to this amplifier or adjust the ACS (Amplifier Configuration Selector).

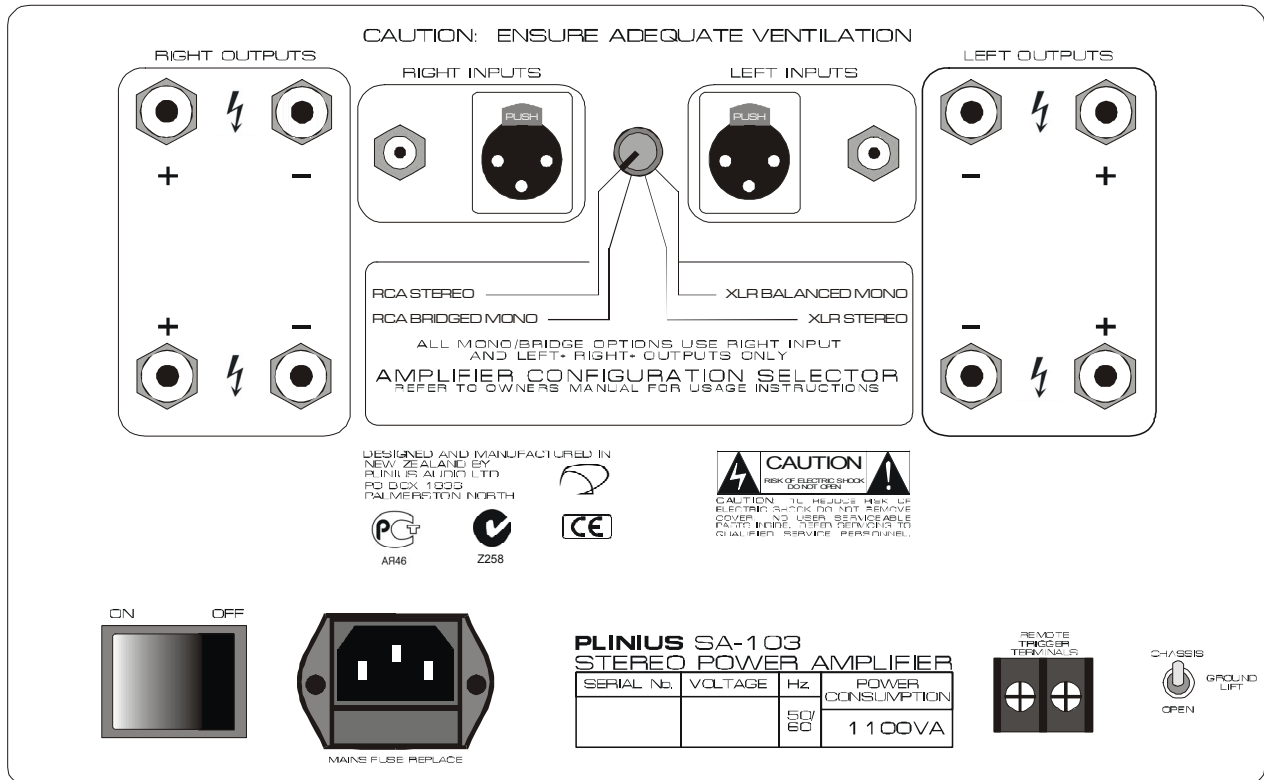

PLINIUS SA-103 REAR PANEL SHOWING ALL THE AVAILABLE FACILITIES INCLUDING INPUT AND OUTPUT TERMINALS, ACS (AMPLIFIER CONFIGURATION SELECTOR), MAINS INPUT AND GROUND LIFT.

INPUT TERMINALS

Input terminals for your Plinius SA-103 Power Amplifier are easily accessible and fitted to the top centre area of the rear panel. A brief summary of connection possibilities is listed below, while a more detailed explanation follows later in this instruction manual.

RCA INPUTS LEFT & RIGHT: These standard RCA terminals are for use with unbalanced signals from most signal sources such as audio preamplifiers.

XLR BALANCED INPUTS LEFT & RIGHT: XLR connectors fitted to this amplifier are for use with balanced line signals from audio preamplifiers. Balanced signals are carried via a three way cable that connects all three pins at each end of the interconnect cable.

The XLR pin configuration used in all Plinius product is:

- PIN 1 to GND**
- PIN 2 to +Signal**
- PIN 3 to -Signal**

NOTE: Because of the way our XLR and balanced inputs are configured it is not possible to connect both XLR and RCA at the same time.

AMPLIFIER CONFIGURATION SELECTOR (ACS)

The Amplifier Configuration Selector (ACS) is a unique switching method that exploits all of the operational features of your Plinius SA-103 Power Amplifier. By using this switch it is possible to operate your amplifier with either balanced or unbalanced signals and achieve a stereo or mono output.

Stereo or Mono use of this amplifier will depend on the type of ancillary equipment employed with your system. If you wish to use this amplifier as a single channel (mono) Power Amplifier in a stereo high fidelity system, then another SA-103 will be required for the other channel. This will provide an extremely high performance option.

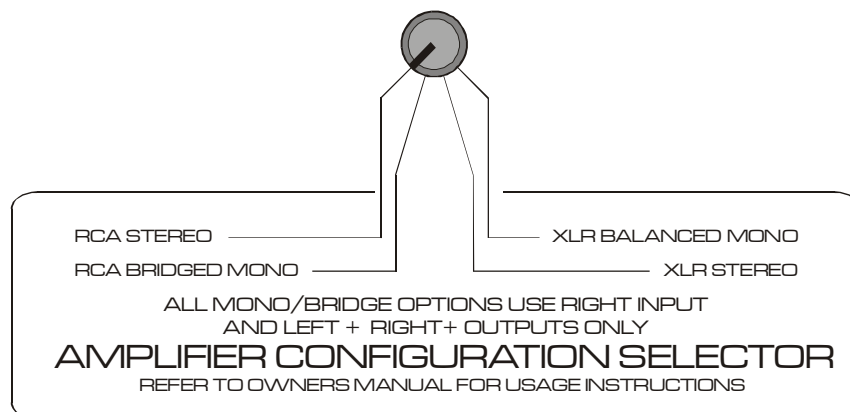

AMPLIFIER CONFIGURATION SELECTOR

The ACS switch options are:

RCA STEREO: This option provides a stereo output via both left and right output channels from a stereo signal connected to both left and right input RCA inputs.

RCA BRIDGED MONO: This option configures your amplifier to drive one loudspeaker from one unbalanced signal fed to the RIGHT RCA input. The loudspeaker is connected to both channels positive (+) output terminals, giving an available power in this mode four times the rated output of the amplifier, approximately 460 watts into 8 ohms. Special care must be taken in connecting the input signal and loudspeakers to ensure safe operation and best possible performance.

XLR STEREO: This option provides a stereo output signal from a balanced stereo input signal connected to both the left and right XLR inputs. All the advantages of balanced line transmission will be realised with good rejection of noise and some freedom from earth or ground loops (hum).

XLR BALANCED MONO: In this mode both channels of your Plinius SA-103 combine to operate as a true balanced mono amplifier, from input to output. This configuration provides the highest quality mono performance from a balanced line input connected to the RIGHT BALANCED XLR INPUT. As with RCA Bridged configuration, the loudspeaker is connected to both channels positive (+) output terminals. Available power in this mode is four times the rated output of the amplifier, approximately 460 watts RMS into 8 ohms. Special care must be taken in connecting the input signal and loudspeakers to ensure safe operation and best possible performance.

BALANCED/UNBALANCED SIGNALS

Balanced or unbalanced input options will depend on the type of signal available from your preamplifier or other equipment. The Plinius SA-103 provides both options to allow you to choose the most suitable preamplifier for your purposes. Plinius Preamplifiers offer both balanced and unbalanced output options.

BALANCED LINE is normally used to transmit signals in a professional environment. Because balanced line effectively reduces or eliminates noise pick-up by the system cabling, it has become increasingly more important in high-quality domestic high fidelity systems.

UNBALANCED leads such as single ended, RCA or coaxial are common and are used in the majority of audio signal systems. The terminal plug and socket are most commonly called RCA and can be found on your Plinius SA-103 for use as the standard input terminals for both left and right inputs.

OUTPUT TERMINALS - STEREO

Output connections for the loudspeakers are provided on the left and right hand side of the rear panel. Two parallel pairs of binding posts for each channel are fitted – these provide ease of use with bi-wiring and multiple cables requiring a large contact area.

OUTPUT TERMINALS - BRIDGED/MONO

In bridged/mono modes, the loudspeakers utilise only the positive (+) outputs of your Plinius SA-103. In this configuration power output to the loudspeakers is dramatically increased (around four times as much), and is commonly used in conjunction with another amplifier for amplification of each channel from the preamplifier.

Please note that in order to achieve STEREO performance in either of the Mono modes, it will be necessary to use two Plinius SA-103 Power Amplifiers - one amplifier each for left and right channels.

MAINS SWITCH

This heavy-duty rocker switch in the centre of the panel turns the Mains/Line Power to the amplifier ON or OFF. An LED in the centre of the front panel indicates that the power is on. When first switched on the power LED will pulse for ten seconds - this is an initialisation sequence, after which the power LED remains lit. The amplifier draws a moderately high current when switched on. Despite the "Soft Start Circuit" within the amplifier reducing current demand on the mains as the amplifier is switched on, it is not good practice to rapidly turn the Mains switch on and off repeatedly.

REMOTE TRIGGER TERMINALS

In order to integrate more effectively into a home theatre system, the Plinius SA-103 has remote trigger terminals fitted to the rear panel. By connecting a processor with a remote trigger signal to these terminals, the SA-103 can be put in and out of Class AB/mute by the processor to which it is connected. When in Class AB/mute the amplifier draws less current and will operate at minimum temperature. The output relays are also open, disconnecting the loudspeakers. This may be of advantage in a multi-amplifier and/or remote installations. The Class AB/mute mode can only be activated via the remote trigger terminals. Polarity of the connections to the remote trigger is not important.

GROUND LIFT SWITCH

This switch is located adjacent to the Mains Input Socket, and allows the signal ground to be disconnected from the chassis. In some installations a hum loop may exist due to duplicate ground paths from different equipment. Use this switch to remove the connection from 0V to ground thus allowing some flexibility in your particular set-up. Note that in both XLR modes the ground lifting switch should always be set to 'chassis'.

MAINS POWER CORD IEC CONNECTOR

This connector is where the mains supply cable from your wall connects to the amplifier. You will notice that a fuse holder is mounted within this connection, and it holds a mains fuse to provide surge and overload protection for your amplifier.

INSTALLATION AND OPERATION

PLACEMENT AND VENTILATION

Your Plinius SA-103 is designed to operate at a moderately high temperature, even more so when used in Class A. The ideal location is on a rigid stand or floor mounted away from direct contact with any temperature sensitive materials or deep pile carpets. The flow of air around the amplifier should also be kept unimpeded, so ensure that the heat sinks (cooling fins) are not covered or restricted in any way to ensure adequate ventilation.

The Plinius SA-103 design incorporates a very high level of mechanical decoupling of the input and output. It can however still be influenced by acoustical feedback in the operating environment. The use of acoustic cones or a suitably spiked amplifier stand or table may further enhance the performance of this amplifier. Consult your **PLINIUS** dealer for further advice if required.

MAINS VOLTAGE CONNECTION

Firstly check that the mains supply voltage printed on the rear of this amplifier is similar to the mains supply voltage in your area. If in doubt, please consult your **PLINIUS** dealer.

Mains supply power connection is via the supplied plug-in lead. A standard IEC socket connects the mains power at the amplifier end while a local mains plug is required at the wall end.

The wiring code used inside all Plinius product is:

Green to Earth/Ground
Blue to Neutral
Brown to Phase/Live

Should a 'local' plug need fitting to the wall end of the lead, ensure that a suitably qualified or experienced service technician wires the plug correctly.

IMPORTANT: **DO NOT POWER UP YOUR AMPLIFIER UNTIL YOU HAVE CONNECTED YOUR INPUT/OUTPUTS CORRECTLY FOR YOUR SYSTEM, (AS EXPLAINED IN THE NEXT SECTION).**

INPUT/OUTPUT CONNECTION

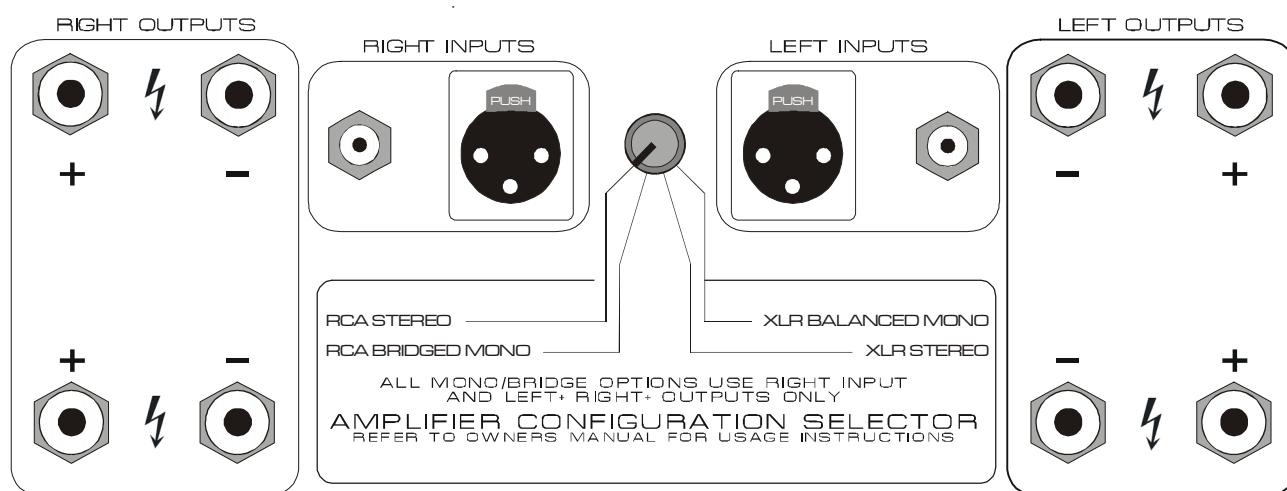

REAR PANEL SHOWING LOCATION OF INPUT/OUTPUT TERMINALS

It is important that you connect your loudspeakers (outputs) and preamplifier (inputs) to the Plinius SA-103 Power Amplifier correctly to ensure the amplifier is not damaged, and sounds it's best with your system. Now that you have read and familiarised yourself with the connections on the back of the amplifier as covered in the previous section, we will describe in detail the different ways in which you can connect the amplifier to your system.

There are essentially four different ways that you can connect your system components to the Plinius SA-103 Power Amplifier:

1. RCA STEREO
2. RCA BRIDGED MONO
3. XLR STEREO
4. XLR BALANCED MONO

RCA STEREO

Connect your preamplifier or input signal to the two RCA inputs at the top of the amplifier back panel. Make sure you connect the red coded cable to the red RIGHT RCA input and the black (or white) cable to the black LEFT RCA input. Also make sure the RCA connectors are a snug fit and are inserted all the way in.

Next connect your loudspeaker wires to the output posts on either side of the rear panel. Connect your right loudspeaker (ie the one on the right of you when seated in your normal listening position) to the right output terminals, ensuring that the red positive (+) terminal is connected to the red terminal on your loudspeaker. Do the same with the black or negative (-) terminals.

Now turn the ACS switch fully clockwise so that it is in the RCA Stereo position. It is now safe to switch on your amplifier.

RCA BRIDGED MONO

This option configures your amplifier to drive one loudspeaker from one unbalanced signal fed to the red RIGHT RCA input. In bridged mono mode the only input made to your preamplifier is to the red RIGHT channel RCA input. The black LEFT channel RCA input is not connected.

Next your loudspeakers are connected to both positive (+) channel output terminals. So the positive red connection on your loudspeaker is connected to the red RIGHT amplifier output, and the negative black connection on the loudspeaker should be connected to the red LEFT amplifier output. **DO NOT CONNECT ANYTHING AT ALL TO THE NEGATIVE (-) TERMINALS. MAKING A CONNECTION TO THE NEGATIVE (-) TERMINALS OF THE AMPLIFIER IN THIS MODE CAN CAUSE SERIOUS DAMAGE!**

You can still connect two loudspeakers using the lower positive (+) amplifier output terminals. This is explained in the bi-wiring section following.

Now turn the ACS switch fully clockwise then one position counter-clockwise so that it is in the RCA Bridged Mono position. It is now safe to switch on your amplifier.

XLR STEREO

Connect your preamplifier or input signal to the two XLR inputs at the top of the amplifier back panel. Make sure you connect the RIGHT XLR input and LEFT XLR inputs to the right and left outputs from your preamplifier respectively. Also make sure the XLR connectors click into place.

Next connect your loudspeaker wires to the output posts on either side of the rear panel. Connect your right loudspeaker (ie the one on the right of you when seated in your normal listening position) to the right output terminals, ensuring that the red positive (+) terminal is connected to the red terminal on your loudspeaker. Do the same with the black or negative (-) terminals.

Now turn the ACS switch fully clockwise then two positions counter-clockwise so that it is in the XLR Stereo position. It is now safe to switch on your amplifier.

XLR BALANCED MONO

As with RCA Bridged Mono, this option configures your amplifier to drive one loudspeaker, but from one balanced line input connected to the RIGHT XLR Input. In balanced mono mode the only input made to your preamplifier is to the RIGHT channel XLR input. The LEFT channel XLR input is not connected.

Next your loudspeakers are connected to both positive (+) channel output terminals. So the positive red connection on your loudspeaker is connected to the red RIGHT amplifier output, and the negative black connection on the loudspeaker should be connected to the red LEFT amplifier output. **DO NOT CONNECT ANYTHING AT ALL TO THE NEGATIVE (-) TERMINALS. MAKING A CONNECTION TO THE NEGATIVE (-) TERMINALS OF THE AMPLIFIER IN THIS MODE CAN CAUSE SERIOUS DAMAGE!**

You can still connect two loudspeakers using the lower positive (+) amplifier output terminals. This is explained in the bi-wiring section following.

Now turn the ACS switch fully counter-clockwise so that it is in the XLR Balanced Mono position. It is now safe to switch on your amplifier.

TERMINATION QUALITY

Quality of the connections must be examined to ensure that high performance trouble free operation is enjoyed. Check that the connections are tight but do not over tighten. If bare wires are used make sure that no loose strands of wire short cross the other terminals or the amplifier chassis. When using plugs such as bananas, be sure to use good quality plugs with a firm fit.

BI-WIRING

Bi-wiring uses two pairs of loudspeaker cables for each channel loudspeaker. You will notice that the rear panel of your Plinius SA-103 has two pairs of output terminals for this purpose. When using bi-wires in a STEREO installation, connect each wire pair to a corresponding pair of binding posts (one cable to the top pair, one cable to the bottom) paying special attention to positive (+) red and negative (-) black polarity. With a MONO setup remember that your speaker wires must use the red positive (+) output posts **ONLY**. Connect one speaker cable to the top positive (+) red binding posts, and the other speaker cable to the lower positive (+) red binding posts.

PHASING (OR POLARITY)

It is important to achieve good stereo imaging in your listening room. By observing the wiring instructions above, each Power Amplifier/loudspeaker combination should be in phase. If you experience poor stereo image and/or a lack of bass, check that the loudspeaker wiring has been connected correctly. We recommend that you use one of the easily obtainable 'test discs' to help you ensure both phasing and channel orientation are correct. If in doubt, consult your **PLINIUS** dealer for advice.

To achieve a sound performance that is correctly aligned to your room, make sure all of the leads carrying signals for the RIGHT channel loudspeaker are connected to the RIGHT input to the amplifier from your preamplifier or CD player etc. Signals for the LEFT channel should be wired in a similar fashion.

CONNECTING THE MAINS SUPPLY

Now that your Plinius SA-103 Power Amplifier is configured to your system correctly, the mains cable can be plugged into the IEC connector on the back of the amplifier. Turn on the power switch on the rear panel. The power LED will pulse for ten seconds as the internal microprocessor and soft start circuitry allow the amplifier internal voltages to settle. Once the amplifier is at full voltage the power LED will stay lit, and the amplifier will be in mute. Press the mute switch to enjoy your new Plinius SA-103 Power Amplifier.

SA-103 FEATURES

ERROR DETECTION

The Plinius SA-103 Power Amplifier has in-built error detection. This will function under the following conditions:

- When the amplifier is overdriven/clipped
- If any internal fuse is damaged

Should either of these circumstances arise the amplifier will disconnect both channels and mute the input. This condition will remain until the input signal level is reduced or the damaged fuse replaced. When error detection is triggered the power LED will turn off and the mute LED will pulse. The internal error LED (located towards the front of the circuit board in the top cavity of the amplifier) will also light.

FUSE PROTECTION

When any internal fuse is damaged one or more fuse warning LEDs will light. These LEDs are under the amplifier lid located near the centre of the main circuit board with the rail fuse holders. If any of the internal fuse LED's are glowing, the lid of the amplifier will need to be removed and the fuse adjacent to the lit LED should be replaced. Replace them with the same type (10 amp normal blow).

IMPORTANT: DO NOT FIT A FUSE WITH A HIGHER RATING.

Please note that fuse failure may indicate a severe problem. Check all speakers and speaker cables for damage/short circuit etc. Should the amplifier continue to exhibit rail fuse failure contact your **PLINIUS** dealer.

ECOLOGIC CONTROL

The Plinius SA-103 is also fitted with a microprocessor which monitors and performs the Bias and Mute functions. It is programmed to switch the amplifier back into Class AB if no signal has been present at the input for a predetermined time. This time can be adjusted to Off, 15, 30 or 60 minutes. During the last minute without signal the bias LED will pulse to indicate the unit is about to return to Class AB. The purpose of this function is to prevent the amplifier being left in Class A while unattended for a long period of time.

To adjust this time constant the amplifier lid must be removed and the small jumper JP4 located on the main circuit board at the front left shifted to the appropriately labelled pins. Please ensure that your amplifier is switched OFF and disconnected from the mains supply before this adjustment is made. The factory setting is 30 minutes.

LED BRIGHTNESS CONTROL

Your Plinius SA-103 has an internal LED brightness control that will adjust all three front panel LED's. A small flat bladed screwdriver can be used to adjust the brightness. The LED brightness control is a small multi turn potentiometer and is located on the front of the main circuit board within the top cavity of the amplifier, and is labelled VR3. Make sure you adjust the correct potentiometer, and remember to remove the mains supply from the amplifier before making any adjustments.

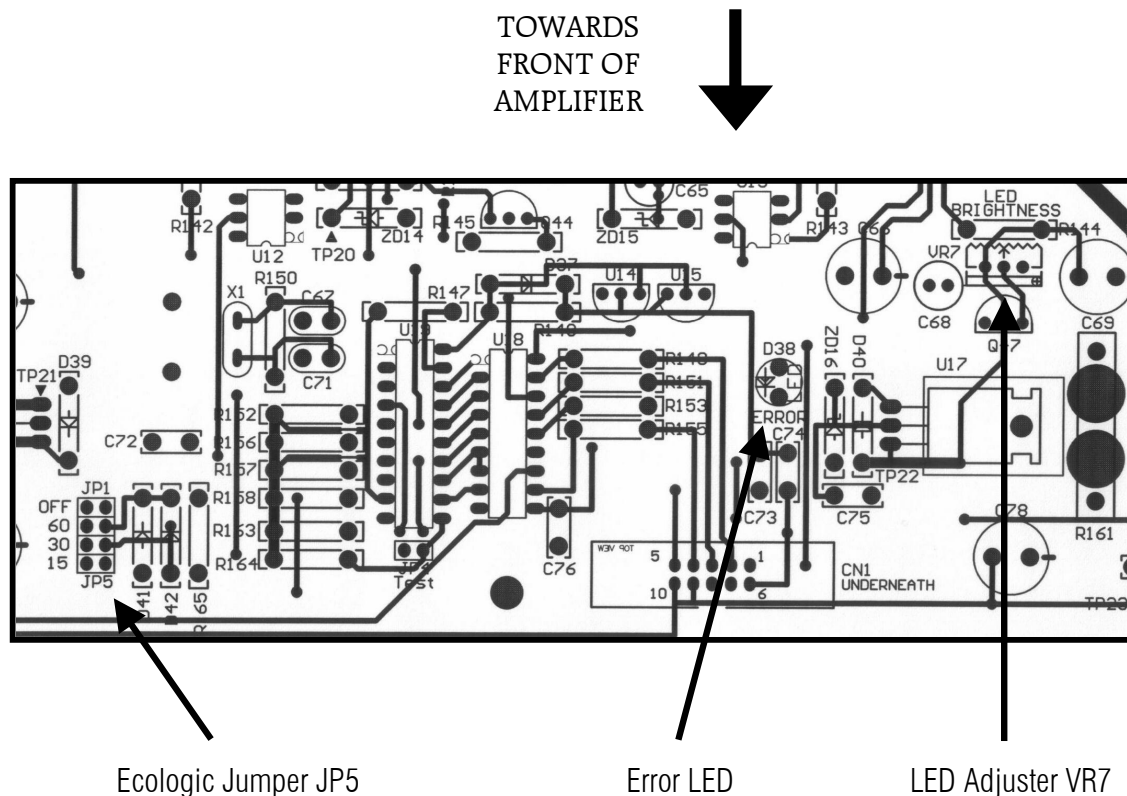

*SECTION OF SA-103 MAINBOARD SHOWING POSITION OF
EKOLOGIC JUMPERS AND LED BRIGHTNESS ADJUSTMENT POTENTIOMETER*

MAINS/LINE FUSE

A Mains/Line fuse is fitted within the IEC Mains/Line socket on the rear of the amplifier. A small drawer at the bottom of this socket may be removed (after the IEC plug is removed) by levering it out with a flat blade screwdriver. The fuse fitted should be rated as specified on the rear panel.

In the unusual event that this fuse should blow, you must first establish the cause of this failure (such as power surges, damaged mains cable etc.) before replacing the fuse with one of the same rating and type.

IMPORTANT: DO NOT FIT A FUSE WITH A HIGHER RATING.

LOUDSPEAKER SELECTION

Your Plinius SA-103 Power Amplifier is designed for use with high fidelity loudspeakers. It should not be used to operate any other type of appliance or equipment.

Choice of loudspeakers is one of personal taste, providing the chosen loudspeakers are suitable for use with your amplifier. Be certain that your loudspeakers can handle most of the rated output power of this amplifier. You may find loudspeaker specifications confusing or misleading so you should discuss this with your audio dealer prior to purchase. As a general rule, the use of high power (200 watt RMS or greater) loudspeakers is recommended and desirable. However, our experience indicates that medium to low power loudspeakers (100 to 200 watt RMS) are quite often suitable for use on this amplifier provided the volume is maintained at a level where no distortion is audible.

Impedance of the loudspeaker load is important to ensure the rated performance of this amplifier. Any combination of loudspeakers may be used but the total average impedance load for each channel should be within a range of 4 to 8 ohms. Again, if you have doubts about the impedance of your loudspeaker configuration, we recommend you speak to your **PLINIUS** dealer.

WHY CLASS A IS BETTER

Class A has always been regarded as the perfect operating mode for audio amplifiers. Many leading amplifier designers and manufacturers world wide recognise that a well designed Class A circuit has inherently lower distortion than any other design.

Class A circuit topology is one in which the total current the amplifier is capable of delivering, is kept flowing in the circuit regardless of demand. In a conventional or Class AB amplifier circuit this current flow varies when demand varies. Furthermore, as current varies, the voltage on the power supply rails (as seen by the output stage) varies too. In a Class A circuit, current draw should be constant therefore there is an absence of the power supply modulation common in Class AB design amplifiers. Pinpoint images, tonal clarification, intertransient silence, more readily defined dynamic shadings, inner detail and authority are all inherent advantages of good Class A design.

SPECIFICATIONS

**125-WATTS RMS PER CHANNEL INTO 8 OHMS.
BOTH CHANNELS DRIVEN FROM 20Hz TO 20kHz.**

- **BRIDGED/BALANCED MONO OUTPUT:** 460 Watts RMS 20Hz to 20kHz into 8 ohms.
- **FREQUENCY RESPONSE:** 20Hz to 20kHz ± 0.2 dB. -3dB at 5Hz and -3dB at 70kHz.
- **DISTORTION:** Typically $< 0.05\%$ THD at rated power. 0.1% THD and IM worst case prior to clipping.
- **SATURATION:** 140 Watts per channel or greater into 8Ω . 220 Watts per channel or greater into 4Ω .
- **CURRENT OUTPUT:** 50A short duration peak per channel. Fuse protected.
- **RISE TIME:** Typically 5μ s.
- **PHASE RESPONSE:** $+0^\circ$ at 20Hz and -14° at 20kHz.
- **HUM & NOISE:** 100dB below rated output 20Hz to 20kHz A-weighted.
- **INPUT SENSITIVITY:** 0.8V RMS for rated output at 1kHz.
- **INPUT IMPEDANCE:** $47k\Omega$.
- **HEIGHT:** 220mm (8 3/4")
- **WIDTH:** 500mm (19 3/4")
- **DEPTH:** 455mm (18")
- **WEIGHT:** 38kg (83lbs)

INDEX

ACS (Amplifier Configuration Selector)	Page 9
Balanced Signal	Page 10
Bias Class A	Pages 7,20
Bias Class AB	Page 7
Bias Switch	Page 7
Bi-wiring	Page 15
Date of Manufacture	Page 3
Ecologic Control	Page 17
Error Detection	Page 17
Front Panel Layout	Page 6
Fuse Protection	Page 17
Ground Lift Switch	Page 11
IEC Power Connector	Pages 11,12
Input Terminals	Pages 9,14,15
LED Brightness Control	Page 18
Loudspeaker Impedance	Page 19
Loudspeaker Power	Page 19
Mains/Line Fuse	Page 18
Mains Supply Connection	Pages 12,16
Mains Switch	Page 11
Mono Operation	Pages 10,14,15
Mute Switch	Page 6
Operating Temperature	Pages 5,12
Output Terminals	Pages 10,14,15
Phasing	Page 16
Placement	Pages 5,12
Rail Fuses	Page 17
RCA Bridged Mono Input	Pages 10,14
RCA Stereo Input	Pages 9,14
Rear Panel Layout	Page 8
Safety Precautions	Page 5
Serial Number	Page 3
Stereo Operation	Pages 10,14,15
Terminations	Page 15
Unbalanced Signal	Page 10
Ventilation	Pages 5,12
XLR Balanced Mono Input	Pages 10,15
XLR Stereo Input	Pages 10,14

CONTACT DETAILS

All operational, technical and descriptive material published here is subject to change at any time without notice. For further product information or queries, please contact us at the address below.

PLINIUS products are designed and manufactured by:

**Plinius Audio Ltd.
P.O. Box 1836
Palmerston North
New Zealand**

Phone: 64 6 354 8583
Facsimile: 64 6 354 8586
Email: info@pliniusaudio.com
Internet: www.pliniusaudio.com

©2005 Plinius Audio Ltd.