

# INSTALLATION INSTRUCTION

## REAR LIFT KIT MFG. NO. 1690045

1. Place set collars on the shaft of the lift lever, the larger set collar on the left side, the smaller set collar on the right side of the shaft. The lip of the left (large) set collar should be facing outward, so that it will fit into the left upright bar assembly on the tractor.
2. Insert the shaft of the lift lever through the hole of the left upright bar assembly, then through the hole of the right upright bar assembly (see figure 1).
3. With the right end of the lift lever shaft flush with the edge of the right upright bar assembly, tighten the right collar so that there is no side play in the shaft.
4. Tighten the left collar so that the lip fits flush inside the hole in the left upright bar assembly.
5. Attach the lift cable to the top of the lift lever bracket, using pivot pin and cotter pin provided (see figure 2).
6. Bring cable forward, passing it through the guard on the PTO bracket (see figure 2).
7. With the cable over the top of the pulley, attach the pulley inside the U-shaped bracket underneath the frame above the lift lever assembly, using the spacer and cable guard provided. Attach the pulley to the bracket using the capscrew and locknut provided. Locate the legs of the cable guard where the cable rides on the pulley, so that the cable does not ride against the cable guard. Tighten capscrew and locknut. (See figure 3).
8. Attach the end of the cable to the lift lever with pin and cotter pin provided.

### NOTE

To install the kit on tractors with hydrostatic drive, an extra cable guard is provided and must be used. Tractors with a three or four-speed shuttle transmission do not use this extra cable guard.

9. On hydrostatic drive units, install the cable guard to the inside rear of the left side plate by removing the nut and lockwasher from the rear capscrew holding on the hydrostatic control spring support (see figure 4). Place the cable guard on the capscrew so that the leg of the guard is over the top of the cable. Replace the lockwasher and nut, making sure that there is at least 1/8 inch clearance between the side of the cable guard and the adjusting nut on the hydrostatic control shaft, so that it will not interfere with the control shaft movement. When the cable guard is properly positioned so that it does not interfere with the control movement, hold it in that position and tighten the nut on the capscrew.

Figure 1.

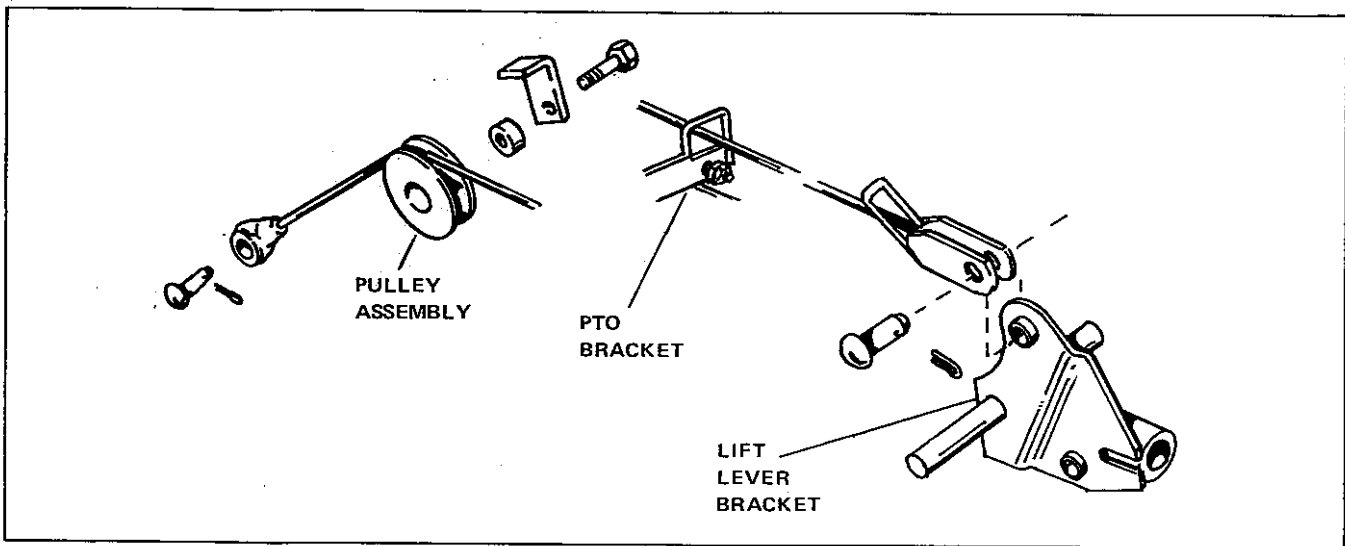

Figure 2.

Figure 3.

Figure 4.