

Crestron **SPK-6L**  
Speaker Kit for Isys® TPS-6L  
Wall Mount Touchpanel

---

Installation Guide



# Contents

<b>Speaker Kit: SPK-6L</b>	<b>1</b>
Description.....	1
Setup.....	2
Supplied Hardware.....	2
Installation.....	3
Resources.....	6
Industry Compliance.....	6
Reference Documents.....	6
Further Inquiries.....	7
Future Updates.....	7
Return and Warranty Policies.....	8
Merchandise Returns / Repair Service.....	8
CRESTRON Limited Warranty.....	8

All brand names, product names and trademarks are the property of their respective owners.  
©2007 Crestron Electronics, Inc.

# Speaker Kit: **SPK-6L**

---

## Description

The SPK-6L is a speaker option for the Isys<sup>®</sup> TPS-6L Wall Mount Touchpanel. Adding the SPK-6L provides amplification of external AV sources, and supports programmable intercom functionality in combination with the touchpanel's built-in microphone.

Refer to the latest version of the TPS-6L Operation & Installation Guide (Doc. 6556) for information on using the SPK-6L. The manual is available from the Crestron website ([www.crestron.com/manuals](http://www.crestron.com/manuals)).

## Setup

### Supplied Hardware

The SPK-6L Speaker Kit consists of three parts. These parts produce an assembly that attaches to the TPS-6L.

#### *Supplied Hardware of the SPK-6L*

DESCRIPTION	PART NUMBER	QUANTITY
Assy, Speaker Box, TPS-6L	4505027	1
Cable Assy, Speaker	4504781	1
Screws, 04-40 x 1/4, Phillips, Pan Head	2007161	12*

\* Two extra screws are provided as spares.

#### *Overall Dimensions – Speaker Box Assembly*

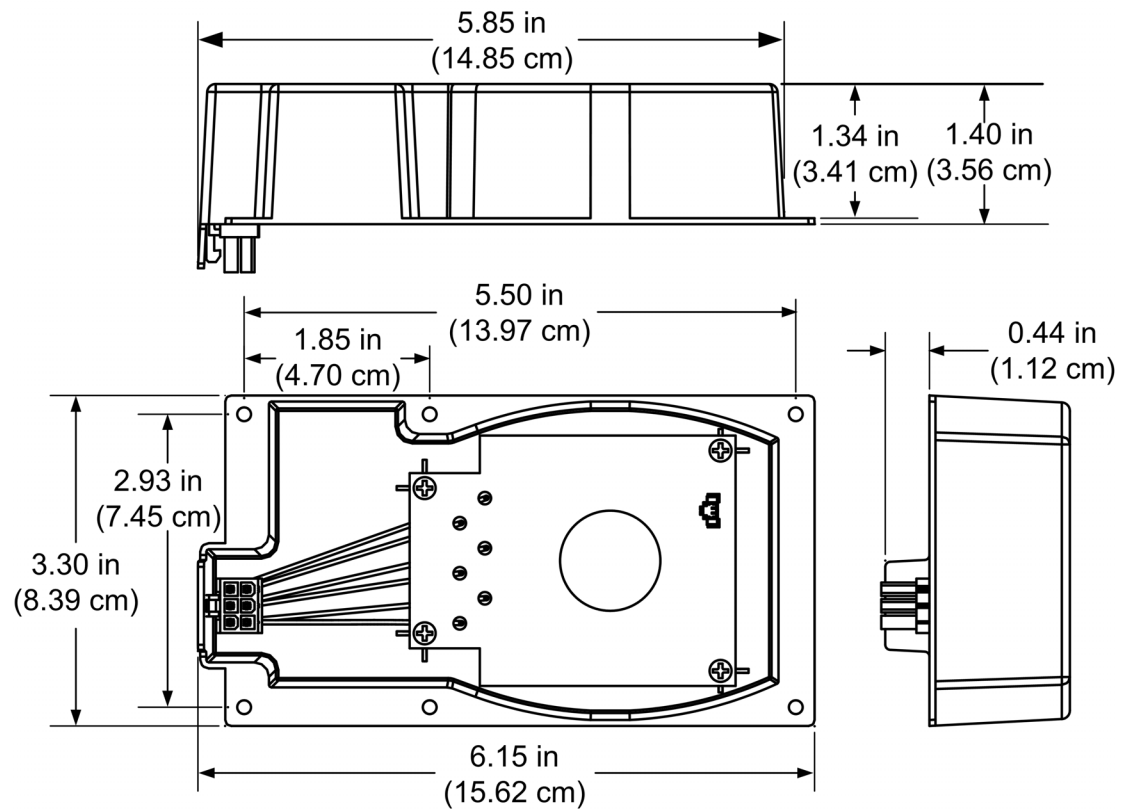

## Installation

The only tool required and not supplied is a #2 Phillips screwdriver. To install the Speaker Kit:

1. Orient the speaker assembly as shown in the following illustration. Use a #2 Phillips screwdriver and attach the speaker to the rear of the touchpanel with four supplied screws.

### *Attaching Speaker*

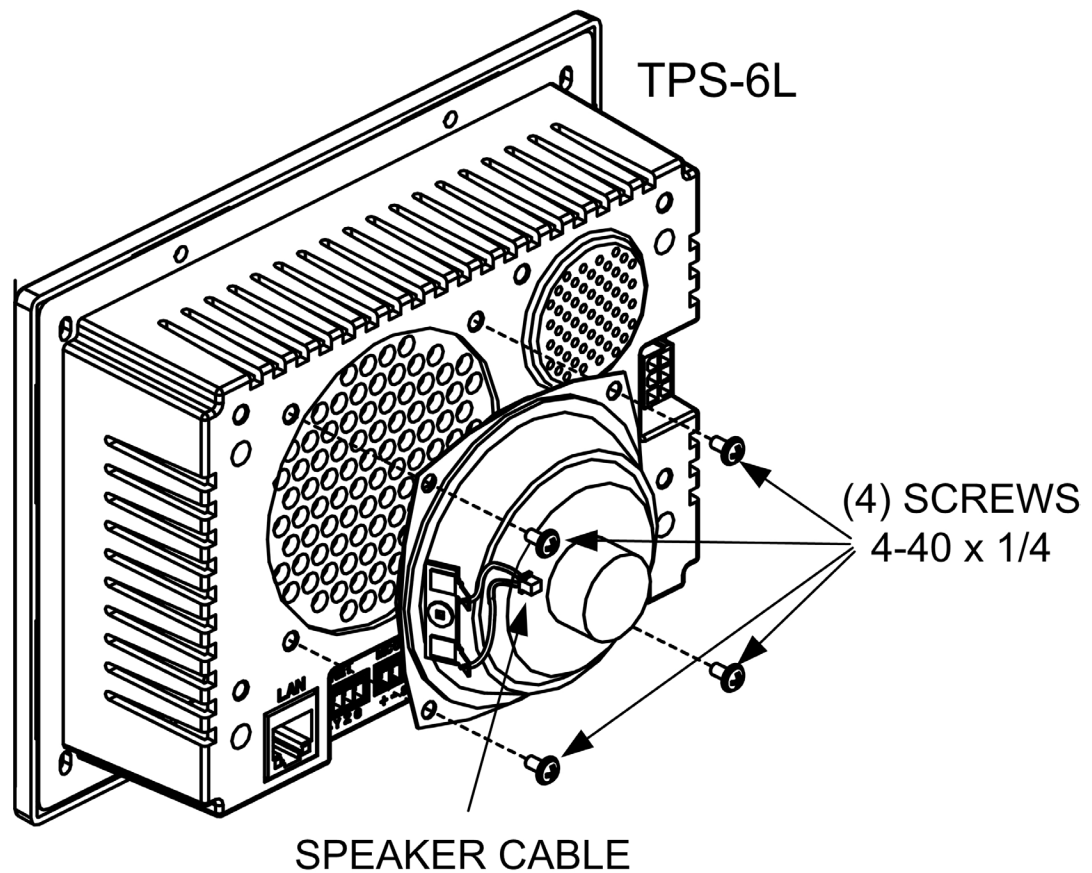

2. Refer to the following illustration and plug the two-conductor speaker cable into the mating connector on the speaker box assembly. Then plug the six-wire cable from the speaker box assembly into the mating connector on the rear of the touchpanel.

**Connecting Cables**

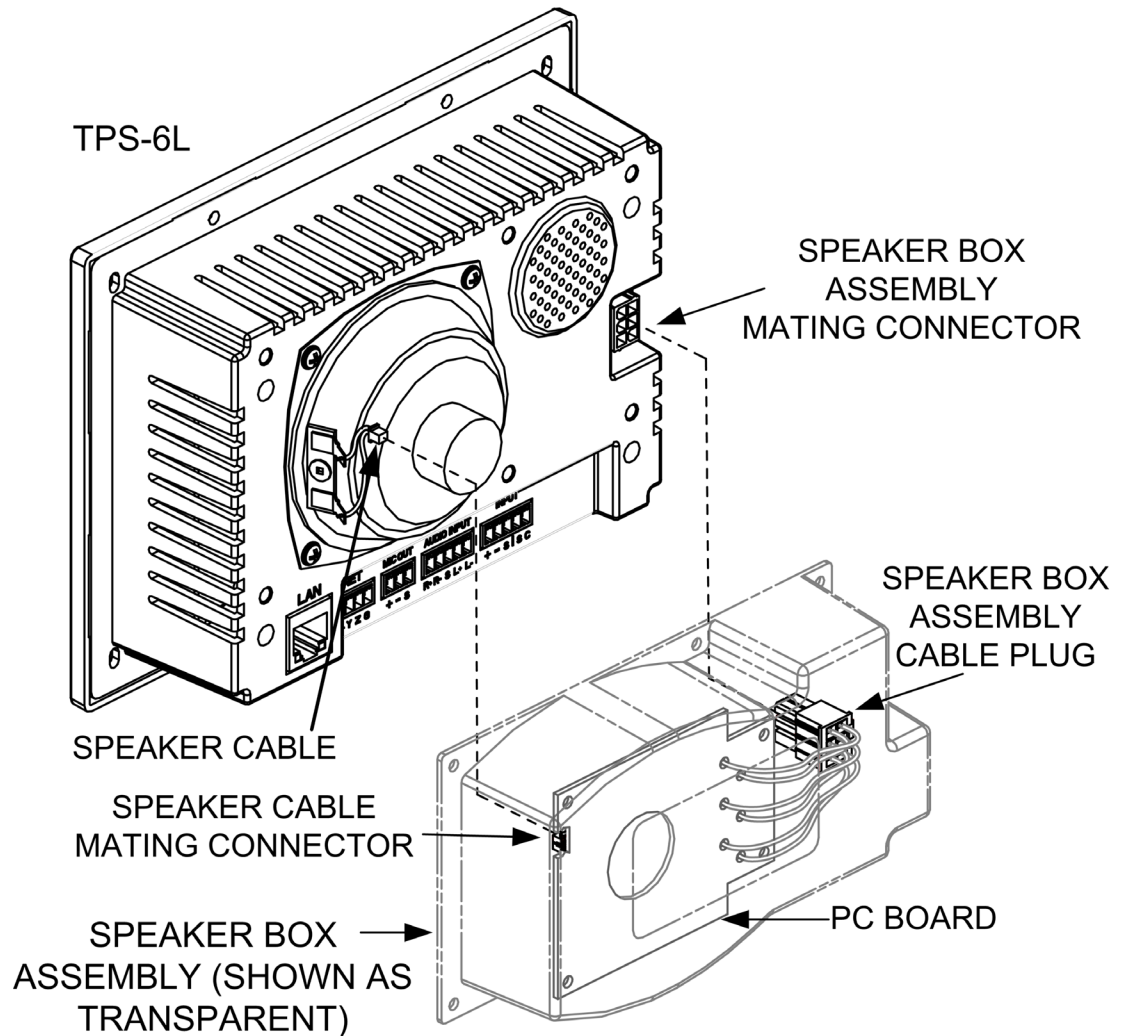

3. Use a #2 Phillips screwdriver to secure the speaker box to the touchpanel with six supplied screws. Refer to the following illustration.

### *Attaching Speaker Box Assembly*

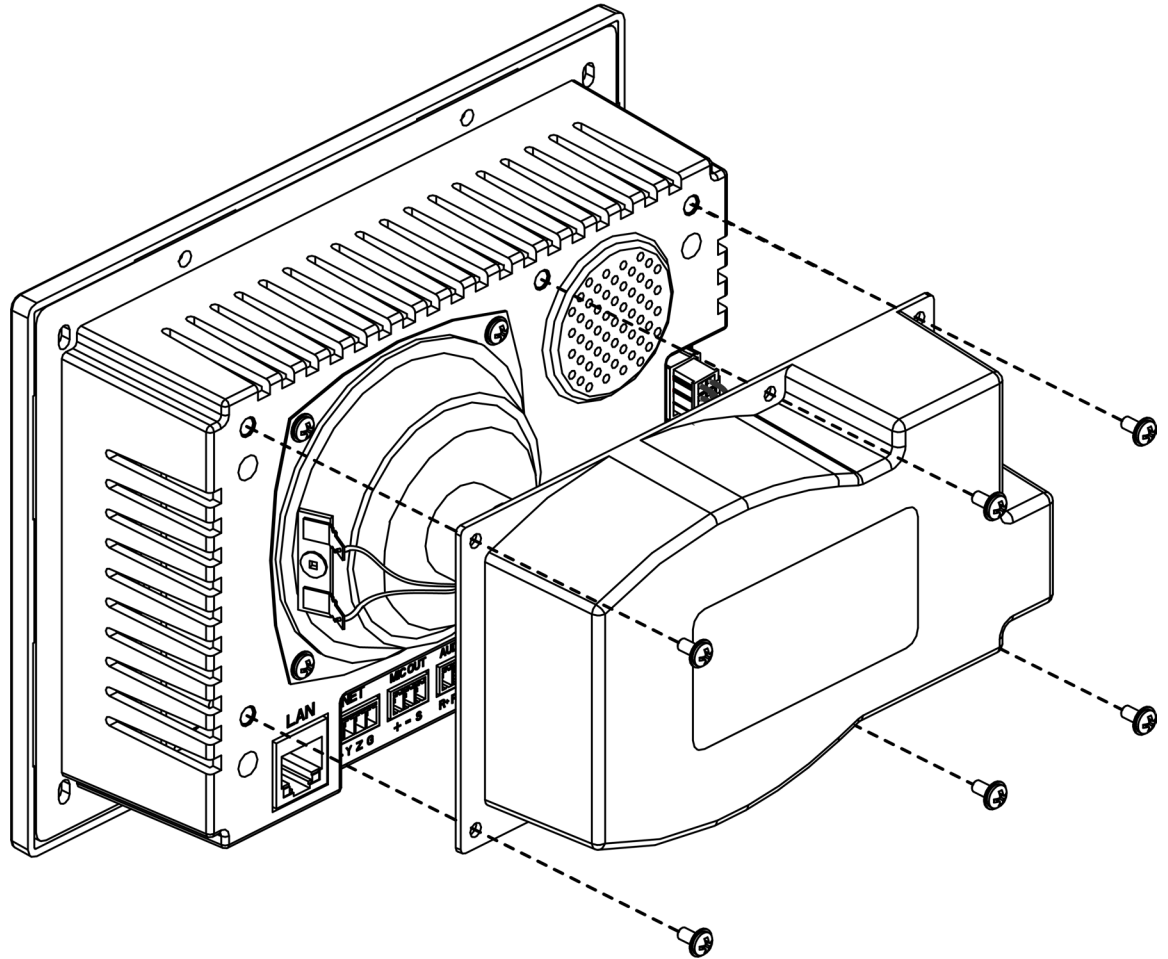

---

## Resources

### Industry Compliance

As of the date of manufacture, the SPK-6L has been tested and found to comply with specifications for CE marking and standards per EMC and Radiocommunications Compliance Labelling.



---

**NOTE:** This device complies with part 15 of the FCC rules. Operation is subject to the following two conditions: (1) this device may not cause harmful interference and (2) this device must accept any interference received, including interference that may cause undesired operation.

This equipment has been tested and found to comply with the limits for a Class B digital device, pursuant to part 15 of the FCC Rules. These limits are designed to provide reasonable protection against harmful interference in a residential installation. This equipment generates, uses and can radiate radio frequency energy and if not installed and used in accordance with the instructions, may cause harmful interference to radio communications. However, there is no guarantee that interference will not occur in a particular installation. If this equipment does cause harmful interference to radio or television reception, which can be determined by turning the equipment off and on, the user is encouraged to try to correct the interference by one or more of the following measures:

- Reorient or relocate the receiving antenna.
  - Increase the separation between the equipment and receiver.
  - Connect the equipment into an outlet on a circuit different from that to which the receiver is connected.
  - Consult the dealer or an experienced radio/TV technician for help.
-



## Reference Documents

The latest version of all documents mentioned within the guide can be obtained from the Crestron website ([www.crestron.com/manuals](http://www.crestron.com/manuals)). This link will provide a list of product manuals arranged in alphabetical order by model number.

### *List of Related Reference Documents*

<b>DOCUMENT TITLE</b>
TPS-6L Isys® 5.7" Wall Mount Touchpanel

## Further Inquiries

If you cannot locate specific information or have questions after reviewing this guide, please take advantage of Crestron's award winning customer service team by calling the Crestron corporate headquarters at 1-888-CRESTRON [1-888-273-7876]. For assistance in your local time zone, refer to the Crestron website ([www.crestron.com/offices](http://www.crestron.com/offices)) for a listing of Crestron worldwide offices.

You can also log onto the online help section of the Crestron website ([www.crestron.com/onlinehelp](http://www.crestron.com/onlinehelp)) to ask questions about Crestron products. First-time users will need to establish a user account to fully benefit from all available features.

## Future Updates

As Crestron improves functions, adds new features and extends the capabilities of the SPK-6L, additional information may be made available as manual updates. These updates are solely electronic and serve as intermediary supplements prior to the release of a complete technical documentation revision.

Check the Crestron website periodically for manual update availability and its relevance. Updates are identified as an "Addendum" in the Download column.

---

## Return and Warranty Policies

### Merchandise Returns / Repair Service

1. No merchandise may be returned for credit, exchange or service without prior authorization from CRESTRON. To obtain warranty service for CRESTRON products, contact an authorized CRESTRON dealer. Only authorized CRESTRON dealers may contact the factory and request an RMA (Return Merchandise Authorization) number. Enclose a note specifying the nature of the problem, name and phone number of contact person, RMA number and return address.
2. Products may be returned for credit, exchange or service with a CRESTRON Return Merchandise Authorization (RMA) number. Authorized returns must be shipped freight prepaid to CRESTRON, 6 Volvo Drive, Rockleigh, N.J. or its authorized subsidiaries, with RMA number clearly marked on the outside of all cartons. Shipments arriving freight collect or without an RMA number shall be subject to refusal. CRESTRON reserves the right in its sole and absolute discretion to charge a 15% restocking fee plus shipping costs on any products returned with an RMA.
3. Return freight charges following repair of items under warranty shall be paid by CRESTRON, shipping by standard ground carrier. In the event repairs are found to be non-warranty, return freight costs shall be paid by the purchaser.

### CRESTRON Limited Warranty

CRESTRON ELECTRONICS, Inc. warrants its products to be free from manufacturing defects in materials and workmanship under normal use for a period of three (3) years from the date of purchase from CRESTRON, with the following exceptions: disk drives and any other moving or rotating mechanical parts, pan/tilt heads and power supplies are covered for a period of one (1) year; touchscreen display and overlay components are covered for 90 days; batteries and incandescent lamps are not covered.

This warranty extends to products purchased directly from CRESTRON or an authorized CRESTRON dealer. Purchasers should inquire of the dealer regarding the nature and extent of the dealer's warranty, if any.

CRESTRON shall not be liable to honor the terms of this warranty if the product has been used in any application other than that for which it was intended or if it has been subjected to misuse, accidental damage, modification or improper installation procedures. Furthermore, this warranty does not cover any product that has had the serial number altered, defaced or removed.

This warranty shall be the sole and exclusive remedy to the original purchaser. In no event shall CRESTRON be liable for incidental or consequential damages of any kind (property or economic damages inclusive) arising from the sale or use of this equipment. CRESTRON is not liable for any claim made by a third party or made by the purchaser for a third party.

CRESTRON shall, at its option, repair or replace any product found defective, without charge for parts or labor. Repaired or replaced equipment and parts supplied under this warranty shall be covered only by the unexpired portion of the warranty.

Except as expressly set forth in this warranty, CRESTRON makes no other warranties, expressed or implied, nor authorizes any other party to offer any warranty, including any implied warranties of merchantability or fitness for a particular purpose. Any implied warranties that may be imposed by law are limited to the terms of this limited warranty. This warranty statement supersedes all previous warranties.

#### Trademark Information

*All brand names, product names and trademarks are the sole property of their respective owners. Windows is a registered trademark of Microsoft Corporation. Windows95/98/Me/XP/Vista and WindowsNT/2000 are trademarks of Microsoft Corporation.*

This page is intentionally left blank.



**Crestron Electronics, Inc.**  
15 Volvo Drive Rockleigh, NJ 07647  
Tel: 888.CRESTRON  
Fax: 201.767.7576  
[www.crestron.com](http://www.crestron.com)

**Installation Guide – DOC. 6625A  
(2018883)**

**11.07**

Specifications subject to  
change without notice.