

Liebert® GXT3-10000T220™

User Manual, 10kVA, 50/60 Hz, 120/208/220V



TABLE OF CONTENTS

IMPORTANT SAFETY INSTRUCTIONS	1
1.0 INTRODUCTION AND SYSTEM DESCRIPTION	4
1.1 Device Overview	5
2.0 UNPACKING THE UPS AND SITE PREPARATION	6
2.1 Inspection	6
2.2 Required Setup Equipment	6
2.3 Unpacking	6
2.4 Environmental Conditions	7
2.5 Access to Area	7
2.6 Floor Loading	7
2.7 Inventory List	7
3.0 INSTALLATION	8
3.1 Electrical preparations	8
3.2 Suggested Cable Sizes	8
3.3 External Protection and Isolating Devices	8
3.4 External Electrical Connections	9
3.5 Connecting Utility and Load	9
3.6 Terminal Blocks for UPS	9
3.6.1 Input and Output Connection Requirements	10
3.7 Connecting Power Cables	11
3.8 External Battery Cabinets	11
4.0 OPERATION	12
4.1 Block Diagram	12
4.2 Control Panel	13
4.2.1 Controls and Messages	13
4.2.2 Battery Setup Parameters	16
4.2.3 Warning Indicators	16
4.2.4 Fault Indicators	17
4.3 Initial UPS Startup Procedure	18
4.4 UPS Shutdown Procedure	18
4.5 Maintenance Bypass Procedure	18
4.6 Return from Maintenance Bypass	19
4.7 Maintenance Breaker, Off Position	19
4.8 Self-Tests	19
4.8.1 Lamp Test	19
4.8.2 Battery Test	19

5.0	MAINTENANCE	20
5.1	Test, Replacement and Disposal of Batteries	20
5.2	Storage	20
5.3	Cleaning	20
6.0	COMMUNICATION	21
6.1	Communication Interface Port	21
6.2	Dry Contact	21
6.2.1	Any Mode Shutdown	21
6.2.2	Battery Mode Shutdown	22
6.2.3	On Battery	22
6.2.4	Low Battery	22
6.3	Liebert IntelliSlot [®] Communication Cards	22
6.3.1	Liebert [®] MultiLink [®]	23
6.4	Remote Emergency Power Off	23
7.0	TROUBLESHOOTING	24
8.0	SPECIFICATIONS	25
9.0	PRODUCT WARRANTY REGISTRATION	27

FIGURES

Figure 1	Liebert GXT3-10000T220 control panel	4
Figure 2	Liebert [®] GXT3-10000T220 [™] front and rear views	5
Figure 3	Unpacking	6
Figure 4	Side view	9
Figure 5	Single source input supply—input and output connections	9
Figure 6	Dual source input supply—input and output connections	10
Figure 7	Hardwire terminals	10
Figure 8	Liebert GXT3-10000T220 with External Battery Cabinet	11
Figure 9	System block diagram	12
Figure 10	Control Panel	13
Figure 11	Menu tree	14
Figure 12	Dry contact pin layout	21

TABLES

Table 1	Overview of UPS devices and batteries	5
Table 2	Connection data *	8
Table 3	Displayed text—system block and main menu	15
Table 4	Battery setup parameters	16
Table 5	Warning indicators	16
Table 6	Fault indicators	17
Table 7	Replacement battery pack	20
Table 8	Troubleshooting guide	24
Table 9	Liebert [®] GXT3 [™] specifications	25
Table 10	Battery cabinet specifications	26
Table 11	Typical battery run times for the Liebert [®] GXT3-10000T230 [™]	26

IMPORTANT SAFETY INSTRUCTIONS

SAVE THESE INSTRUCTIONS

This manual contains important safety instructions. Read all safety and operating instructions before operating the uninterruptible power system (UPS). Adhere to all warnings on the unit and in this manual. Follow all operating and user instructions. This equipment must be operated only by individuals who are properly trained and qualified.

This product is designed for commercial/industrial use only. It is not intended for use with life support and other designated “critical” devices. Maximum load must not exceed that shown on the UPS rating label. The UPS is designed for data processing equipment. If uncertain, consult your dealer or local Emerson Network Power representative.

This UPS is designed for use on a properly earthed (grounded), 208 or 220 VAC, 50Hz or 60Hz supply, for installation by qualified personnel. A qualified electrician must review and approve customer-supplied wiring, circuit breakers and intended loads and verify correct input, output and earth connections to ensure compliance with technical standards and local electrical codes of practice. Installation instructions and warning notices only for use by properly trained and qualified personnel are located after the UPS operator instructions in this manual.

Install the UPS in a clean environment, free from moisture, flammable liquids, gases and corrosive substances.

This UPS contains no user-serviceable parts except the internal battery pack. The UPS On/Off push buttons do not electrically isolate internal parts. Under no circumstances attempt to gain access internally due to the risk of electric shock or burn.

Do not continue to use the UPS if the front panel indications are not in accordance with these operating instructions or the UPS performance alters in use. Refer all faults to your dealer.

Servicing of batteries should be performed or supervised by personnel knowledgeable of batteries and the required precautions. Keep unauthorized personnel away from the batteries. Proper disposal of batteries is required. Refer to your local laws and regulations for disposal requirements.

Never block or insert any object into the ventilation holes or other openings.

DO NOT CONNECT equipment that could overload the UPS or demand DC current from the UPS, for example: electric drills, vacuum cleaners, laser printers, hair dryers or any appliance using halfwave rectification.



WARNING

The battery can present a risk of electrical shock and high short circuit current. The following precautions should be observed before replacing the battery pack:

- Wear rubber gloves and boots
- Remove rings, watches and other metal objects.
- Use tools with insulated handles.
- Do not lay tools or other metal objects on the batteries.
- If the battery kit is damaged in any way or shows signs of leakage, contact your local Emerson representative immediately.
- Do not dispose of batteries in a fire. The batteries may explode.
- Handle, transport and recycle batteries in accordance with local regulations.
- Even when all switches and interrupters are open, hazardous voltages are present within the UPS; any operation that requires protective panels to be opened or removed may be carried out by Emerson-authorized technical personnel only.



WARNING

Although the Liebert® GXT3™ has been designed and manufactured to ensure safety, improper use can result in electrical shock or fire. To ensure safety, observe the following precautions:

- Turn Off and isolate the Liebert GXT3 before cleaning it. Use only a soft cloth; never use liquid or aerosol cleaners.
- Never block or insert any objects into the ventilation holes or other openings of the UPS.
- Do not place the Liebert GXT3 power cord where it might be damaged.



CAUTION

- When installed in EU countries, the Liebert® GXT3-10000T220™ is not intended to operate with isolated neutral (IT systems). Neutral connector must be present and connected to the UPS.
- Even with all buttons OFF (see **4.2 - Control Panel**) the device (UPS) is **not** isolated from the utility. To isolate completely from the utility, the power cables must be disconnected.
- In case of interruption of the utility voltage, the integrated battery maintains the power supply to the user equipment.
- Lay all cables so that nobody can stand on them or trip over them. When connecting the UPS to the power supply, follow the instructions in **3.0 - Installation**.
- In emergencies (e.g., damaged case, controls or power cables, penetration of liquids or foreign matter), switch off the device and contact the appropriate customer service representative.
- Do not connect equipment that will overload the UPS (e.g., laser printers or vacuum cleaners) or demand DC-current (e.g., half-wave rectifiers).
- When cleaning the unit, follow the instructions in **5.0 - Maintenance**.
- The sum of the leakage currents (protective conductor current) of the UPS and the connected devices exceeds 3.5 mA for all ratings of the UPS. Ground (earth) connection is essential before connecting supply.
- Data transmission lines should not be connected or disconnected during a thunderstorm.
- Emergency Power Off (EPO) input is on the rear of the unit (see **6.4 - Remote Emergency Power Off** and **3.6 - Terminal Blocks for UPS**). When this connection is open, the logic circuit will immediately shut down the UPS output.
- When installed in EU countries, an Emergency Switching Device (E.S.D.) must be fitted downstream of the UPS for the wiring installation safety to comply with the European Harmonized Document HD384-4-46 S1.
- Maintenance bypass breaker is for the use of service personnel only. The breaker is on the rear of the unit. To operate the breaker, the captive screw must be loosened and the guard must be lifted out of position.

Leakage Current



WARNING

Connect the ground (earth) safety conductor before connecting any other cables.

ELECTROMAGNETIC COMPATIBILITY—The Liebert® GXT3™ complies with the limits for a Class A Digital Device, Pursuant to Part 15 of FCC rules. Operation is subject to the following conditions:

- This device may not cause harmful interference
- This device must accept any interference received, including interference that may cause undesired operation. Operating this device in a residential area is likely to cause harmful interference that users must correct at their own expense.

The Liebert GXT3 series complies with the requirements of EMC Directive 2004/108/EC and the published technical standards. Continued compliance requires installation in accordance with these instructions and use of accessories approved by Emerson.

NOTICE

Operating the Liebert GXT3 in residential areas may cause radio interference that the user must correct at his own expense.

Information for the Protection of the Environment

UPS SERVICING—This UPS makes use of components dangerous for the environment (electronic cards, electronic components). The components removed must be taken to specialized collection and disposal centers.

1.0 INTRODUCTION AND SYSTEM DESCRIPTION

Congratulations on your choice of the Liebert® GXT3™-10000T220 UPS. It provides conditioned power to microcomputers and other sensitive electronic equipment.

When generated, AC power is clean and stable. However, during transmission and distribution it is subject to voltage sags, spikes and complete power failure that may interrupt computer operations, cause data loss and damage equipment. The Liebert GXT3-10000T220 protects equipment from these disturbances.

The Liebert GXT3-10000T220 is an on-line UPS. An on-line UPS continuously conditions and regulates its output voltage whether utility power is present or not. It supplies connected equipment with clean sinewave power. Sensitive electronic equipment operates best from sinewave power.

The liquid crystal display is used for controlling operation of the UPS, as well as monitoring its status, condition, alarm status and history. For ease of use, the Liebert GXT3-10000T220 features a light-emitting diode (LED) display to indicate operational status. It also provides self-diagnostic tests, a combination On/Alarm Silence/Battery Test button, a Standby button, user configurable program and two levels of alarms when the unit is operating on battery.

The Liebert GXT3-10000T220 has an interface port for communication between the UPS and a network server or other computer system. This port provides detailed operating information including voltages, currents and alarm status to the host system when used in conjunction with Liebert's MultiLink® software. Liebert MultiLink software may also control UPS operation remotely.



CAUTION

This UPS may be operated only by properly trained and qualified personnel.

Figure 1 Liebert GXT3-10000T220 control panel



1.1 Device Overview

The following table provides an overview of the various versions of the device:

Table 1 Overview of UPS devices and batteries

Type	Model #	Nominal power
UPS with Integrated Battery	Liebert® GXT3-10000T220™	10000VA/90000W
Battery Cabinet	Liebert GXT3-240TBATTCE™	—

Figure 2 Liebert® GXT3-10000T220™ front and rear views

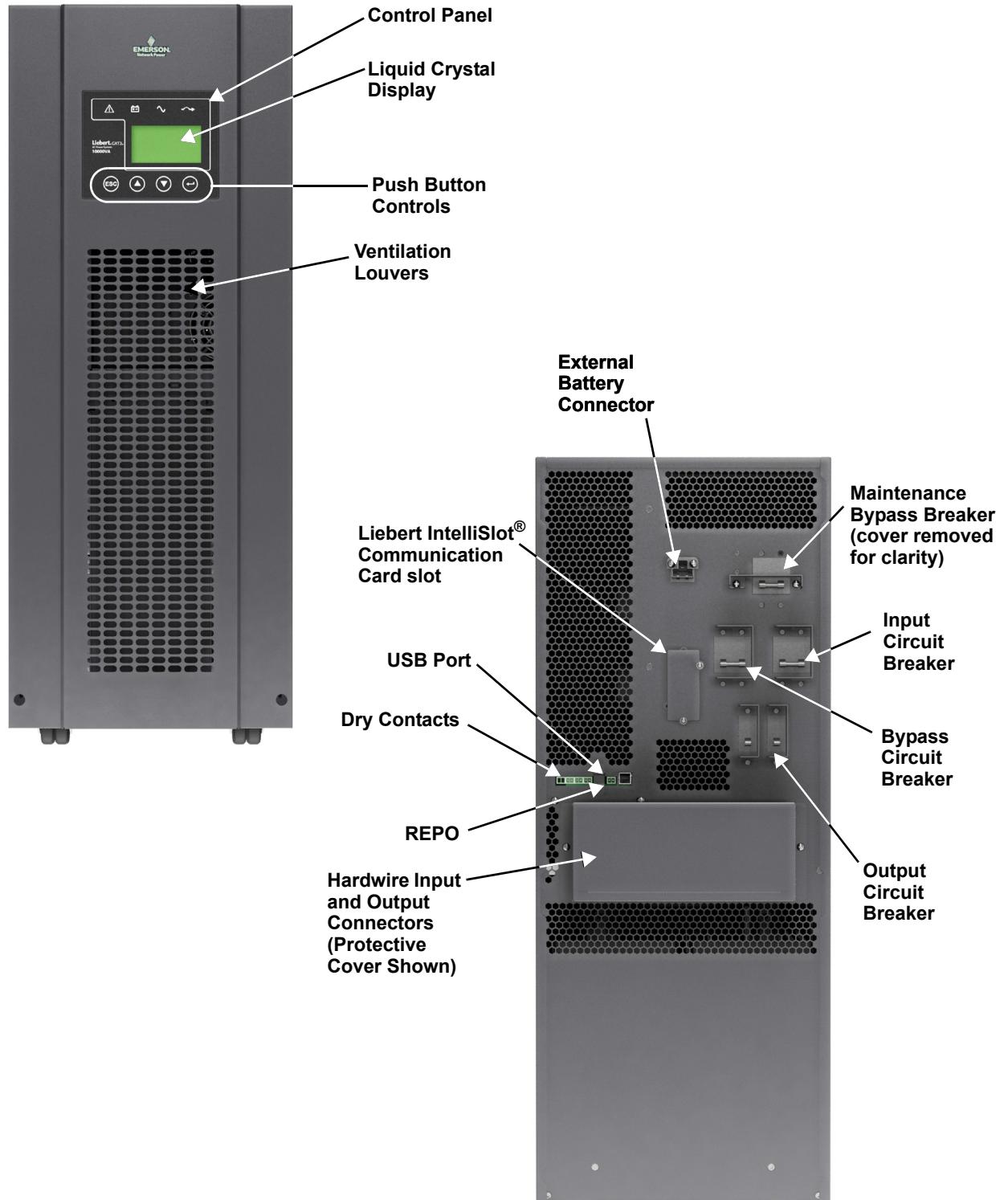

2.0 UNPACKING THE UPS AND SITE PREPARATION

2.1 Inspection

Upon receiving your Liebert® GXT3-10000T220™, examine the packaging for any signs of mishandling or damage. While removing shipping materials, inspect the UPS for damage. If any damage is noted, notify your local Liebert representative and your carrier.

2.2 Required Setup Equipment

The following tools are required to set up your Liebert GXT3-10000T220:

- pallet jack
- utility knife or scissors
- screwdrivers—Phillips and straight blade

2.3 Unpacking

Exercise care when removing the packaging to avoid damaging the UPS. Check all packaging to ensure that no items are discarded. Remove the packaging following the sequence in **Figure 3**.

WARNING

The UPS is heavy and will roll when on an incline. When removing the unit from its shipping pallet, use at least two persons.

1. Using a pallet jack, move the Liebert GXT3-10000T220 near its installation site.
2. Unlock all the snaps securing the shipping case to the shipping pallet.
3. Lift the shipping case off the UPS.
4. Remove the EPE packing cushions from around the Liebert GXT3-10000T220.
5. Remove the ramp from the front and slip into the slot on the front of the shipping pallet.
6. Roll the UPS off the shipping pallet.

Figure 3 Unpacking

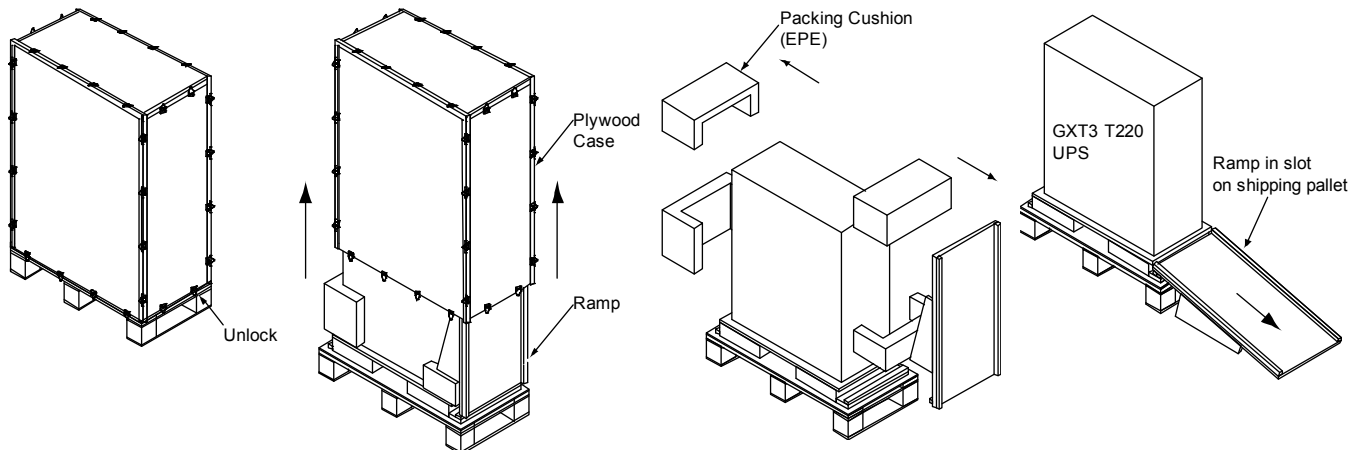

Storage

If the UPS will be stored, it must be placed indoors in a clean, dry area. Protect all the equipment, including its batteries, from extreme temperatures, high humidity, spills and other damaging conditions. Refer to **Table 9** for permissible environmental conditions for storage.

Handling

The equipment must be kept upright at all times and handled with care. It may be damaged if dropped or subjected to severe impact.

2.4 Environmental Conditions

Install the Liebert® GXT3™ indoors in a controlled environment where it cannot be accidentally turned off. Place it on a level, even surface in an area with unrestricted airflow around the unit. The installation location must be free of water, flammable liquids, gases, corrosives and other conductive contaminants. Maintain a minimum clearance of 100mm (4 inches) in the front and rear of the UPS. Maintain an ambient temperature range of 0 to 40°C (32 -104°F).

See **8.0 - Specifications** for acceptable environmental conditions.



NOTE

UPS operation in sustained temperatures outside the range of 15-25°C (59°-77°F) will reduce battery life.

2.5 Access to Area

The area where the Liebert GXT3-10000T220 is to be placed must have sufficient space for installation procedures and for routine maintenance. The UPS is narrow enough to pass through standard doorways.

2.6 Floor Loading

Ensure that the floor where the UPS will be installed will support the unit's weight (see **Table 9** for the unit's weight).

2.7 Inventory List

- CD containing:
 - Liebert MultiLink® shutdown software
 - Configuration Software
 - User Manual
- Terminal Block Communication terminals
- Floor-mount brackets
- Warnings, safety instructions booklet and WEEE recycling sheet (ISO 14001 compliance)
- USB cable
- Hardwire terminal block cover plate and mounting screws
- Single input bypass jumper
- Battery cabinets contain one DC power cable

3.0 INSTALLATION

3.1 Electrical preparations

Before beginning installation, the input source must be isolated and locked out to prevent connection during installation. The input circuit breaker on the rear of the UPS must be in the Off position.



WARNING

Installation may be carried out only by qualified technicians and in conformity with the applicable safety standards.



WARNING

Electric shock hazard: Even when the unit is disconnected from the utility, hazardous voltage may still be supplied by the battery. Both poles must be disconnected before any work is performed inside the UPS.



WARNING

If the Maintenance Bypass Breaker is in the Bypass position, output power is available immediately upon application of AC input.

3.2 Suggested Cable Sizes

Table 2 Connection data *

Description	Units	Liebert® GXT3-1000T220™
Connector size	AWG (mm ²)	6 (10)
Max input current	Arms	56*
Input cable size (Ø and neutral)	AWG (mm ²)	6 (10)
Max output current	Arms	56*
Output cable size (Ø and neutral)	AWG (mm ²)	6 (10)
Ground (Earth) Cable Size	AWG (mm ²)	6 (10)
Terminal Torque	lb-in (Ncm)	10 (113)

* Cable must be 90°C copper wire



NOTE

To reduce electromagnetic interference:

- Enclose input and output cables to the UPS in separate metal conduits.
- Use shielded communication cables and route separately from power cables

3.3 External Protection and Isolating Devices

An external 70A disconnect switch must be installed upstream of the UPS to protect power cabling and provide a means of isolating the UPS from utility.



WARNING

The following label must be displayed on all switching devices installed in the same electrical system as the UPS, even when these are located at a distance from the area.

ENSURE THAT THE UNINTERRUPTIBLE POWER SYSTEM IS ISOLATED BEFORE WORKING ON THIS CIRCUIT



CAUTION

A disconnect switch must be provided by others for AC output circuit. To reduce the risk of fire, connect only to a circuit provided with branch circuit overcurrent protection for 70A rating in accordance with the National Electric Code, ANSI/NFPA 70.

3.4 External Electrical Connections

The external electrical connections may be accessed by removing the protective panel on the rear of the UPS (see **Figure 2**) (panel ships loose from factory). Select a conduit knockout appropriate for your cabling, based on local electrical codes.



WARNING

Before removing electric protective panel, ensure that the UPS is isolated.

Figure 4 Side view

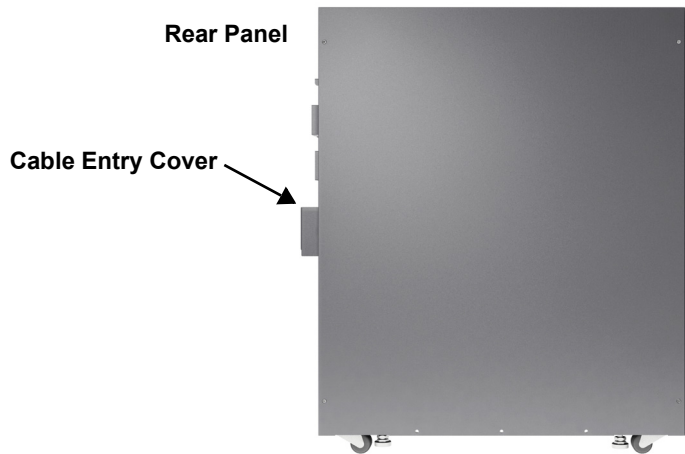

NOTE

Once installation has been completed, adjust leveling feet to prevent the UPS from moving.

3.5 Connecting Utility and Load

Connect the utility supply to the input terminals of the UPS. If the Liebert® GXT3-10000T220™ is supplied by single-phase utility, connect the live phase to input L1.

3.6 Terminal Blocks for UPS



CAUTION

Power is connected through the input breaker, even when the UPS is in bypass mode. Opening the input breaker when in bypass mode will disconnect output power to the connected load.

Figure 5 Single source input supply—input and output connections

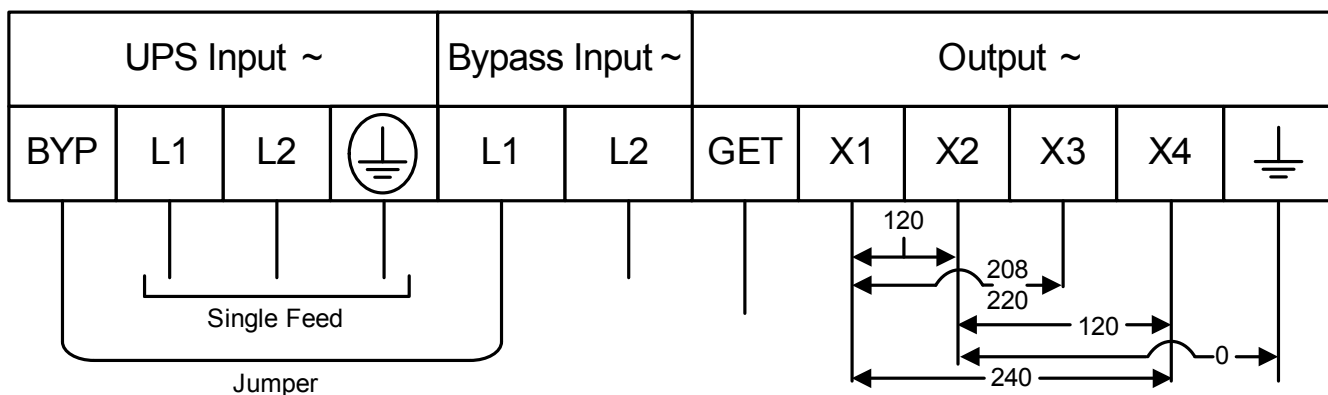

Figure 6 Dual source input supply—input and output connections

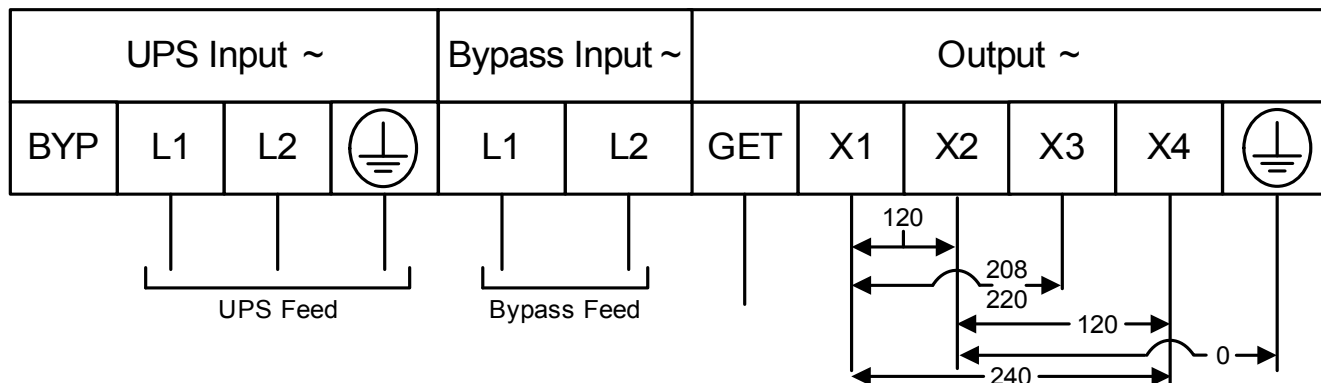
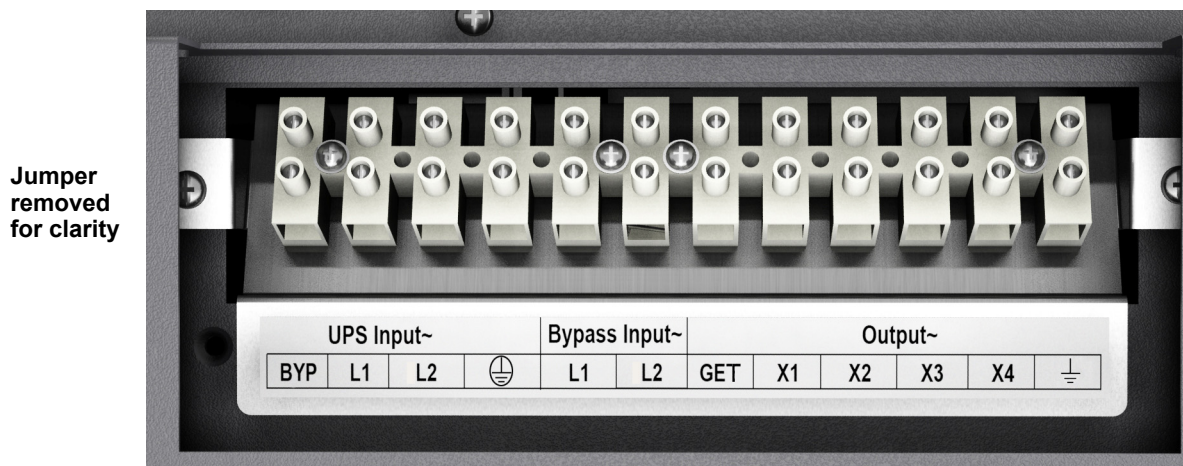

Figure 7 Hardwire terminals



3.6.1 Input and Output Connection Requirements

- Any 120V loads must be distributed evenly between X1-X2, X1-X4 and X4-X2. Do not connect loads between X3-X2 or between X3-X4—these are not standard voltages.
- The single-phase isolation output transformer is a separately derived source. The output Neutral (X2) is bonded to Ground within the UPS cabinet. No other bonding wire is needed.
- Install a Grounding Electrode Terminal (GET) to the nearest grounding electrode in the building grounding electrode system. If the grounding electrode conductor must be protected, non-metallic conduit is recommended. If metal conduit must be used, bond both ends of the conduit to the grounding electrode conductor. Conduit is not an acceptable grounding electrode conductor.
- The utility may be derived from a single-phase or three-phase source. The line-to-ground voltages are dependent on the grounding of the utility and do not affect the output voltages. Do not use a floating AC source.
- With dual input source configuration, both sources are tied together within the UPS cabinet. Two additional ground screw terminals are supplied for use as needed.

3.7 Connecting Power Cables

1. Open the UPS input breaker.
2. Open the UPS bypass breaker.
3. Set the maintenance breaker to the Bypass position.
4. Remove the electrical connection protective panel, if installed, from the rear UPS panel.
5. Connect loads to the output terminals as illustrated in **Figure 7**.
6. Connect the utility to the corresponding input terminals (see **Figure 7**).
 - If the bypass input is to be supplied separately, connect the bypass source to the corresponding bypass terminals.
 - If the UPS is supplied from a single feed, connect the factory-supplied jumper between terminal UPS Input-BYP and Bypass Input-L1.

3.8 External Battery Cabinets

Up to four external battery cabinets may be connected to the Liebert® GXT3-10000T220™. A cable to connect the battery cabinet and the Liebert GXT3-10000T220 is supplied with each battery cabinet.

Open the breaker before making battery cable connections.

Plug one end of this cable into the UPS and the other end into the battery cabinet—slotted fittings on each end ensure that the connection is properly made. If your UPS has an integrated battery, a compensating current may occur during connection. Once both ends of the cable have been connected, the circuit breaker on the external battery cabinet must be closed.

Figure 8 Liebert GXT3-10000T220 with External Battery Cabinet

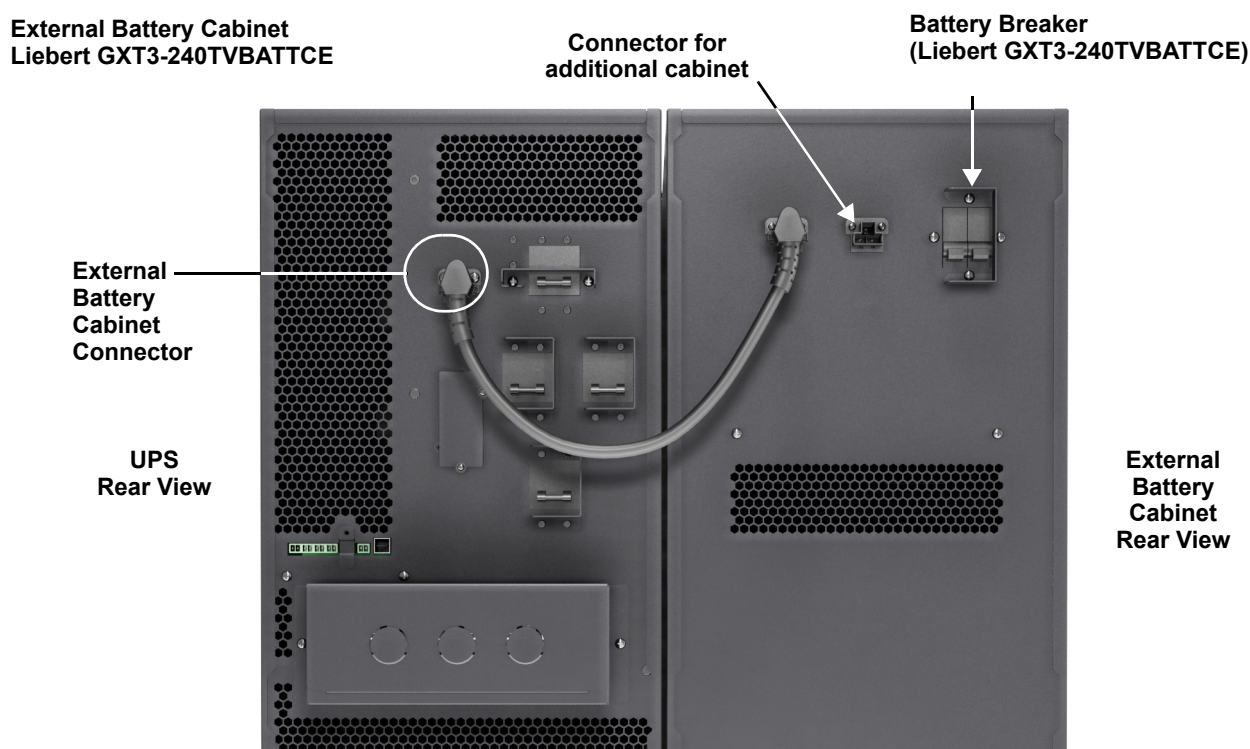

CAUTION

Battery maintenance must be performed only by authorized personnel who are properly trained and qualified.

External battery cabinets are hot-swappable; they can be replaced during normal UPS operation.

DO NOT connect or disconnect batteries when the UPS is in Battery Mode.

4.0 OPERATION

4.1 Block Diagram

The Liebert® GXT3-10000T220™ consists of the following main components:

- 2 utility inputs with separate breakers—utility and bypass
- rectifier/booster, inverter and charger
- electronic bypass
- 2-position Maintenance Bypass Breaker—UPS and BYPASS
- integrated battery

Figure 9 System block diagram

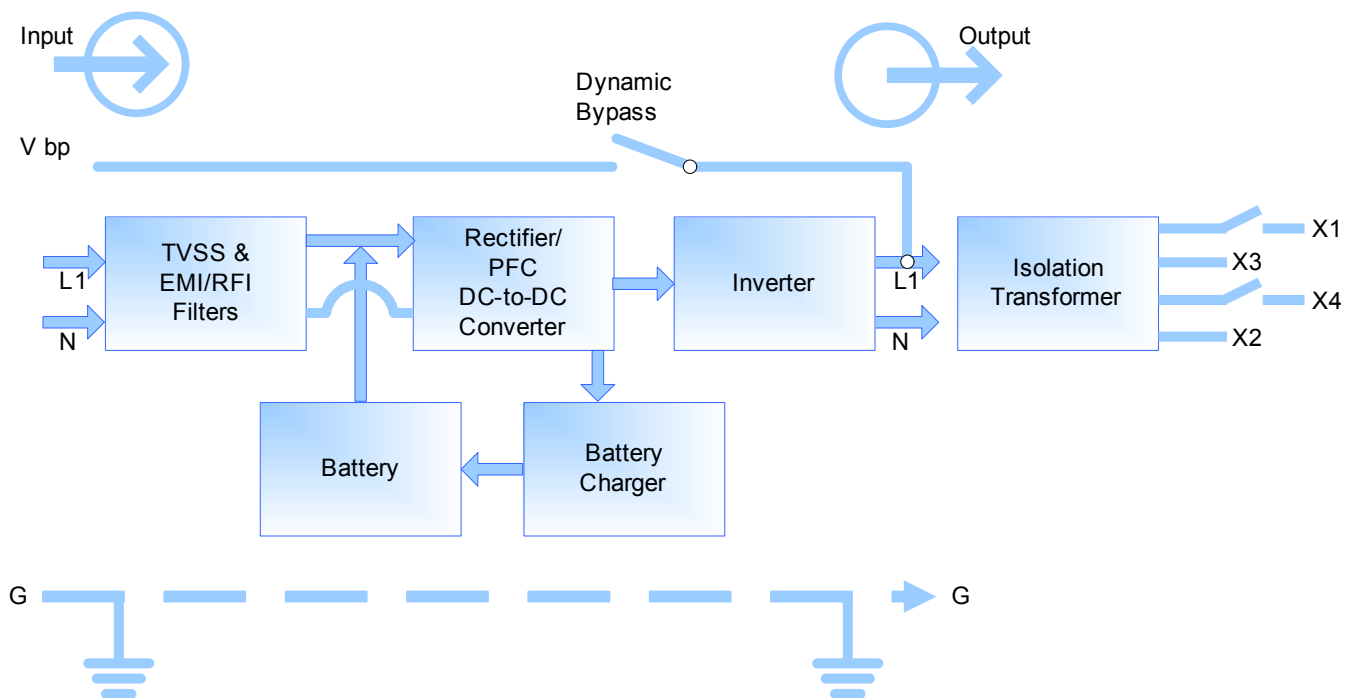

4.2 Control Panel

The Control Panel's LCD and buttons are used to initiate various UPS operations, tests and commands and to view the status of the UPS.

By pressing the Menu Up ▲ or Menu Down ▼ and Enter keys ↵, it is possible to scroll through the various menus. For details, see 4.2.1 - Controls and Messages and Figure 11.

Figure 10 Control Panel

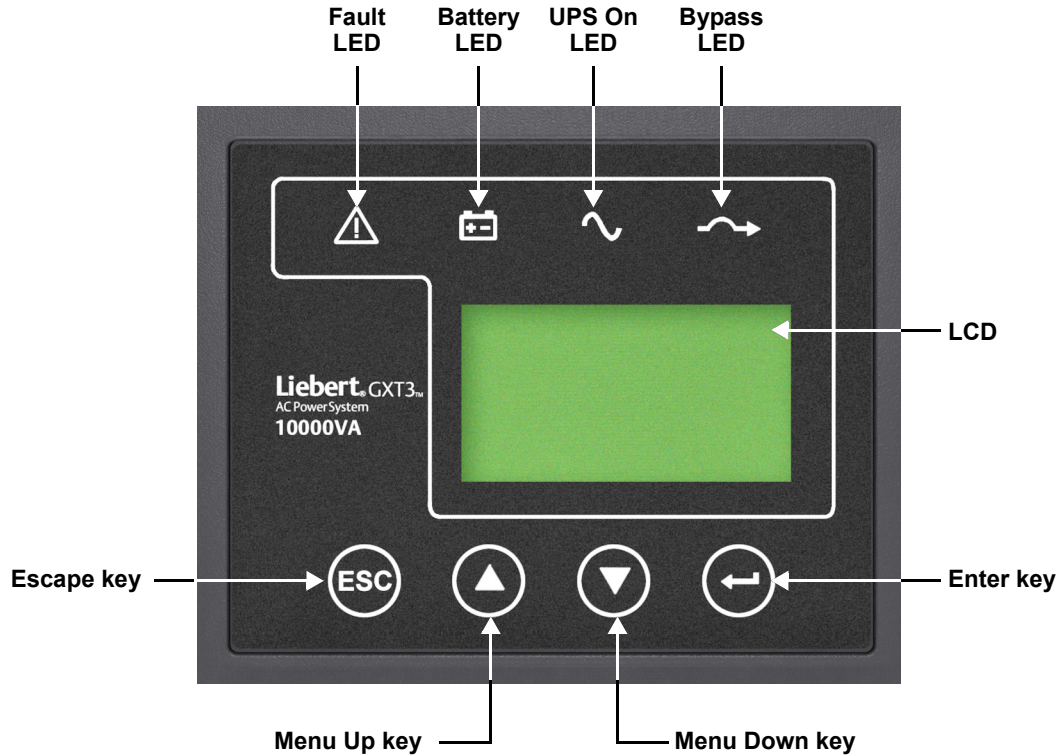

4.2.1 Controls and Messages

Lighted LEDs

- UPS ON—UPS is in normal, online operation
- BYPASS—Load is supplied by the utility via automatic bypass
- BATTERY—Load is supported by the battery
- FAULT—A problem has developed within the UPS

Flashing LED

When the BYPASS LED is flashing, the utility is out of tolerance.

NOTICE

Risk of loss of power to connected load. Can cause equipment damage.

Never switch the UPS Off or switch from Online to Bypass in this status, because the load would no longer be supplied.

Figure 11 Menu tree

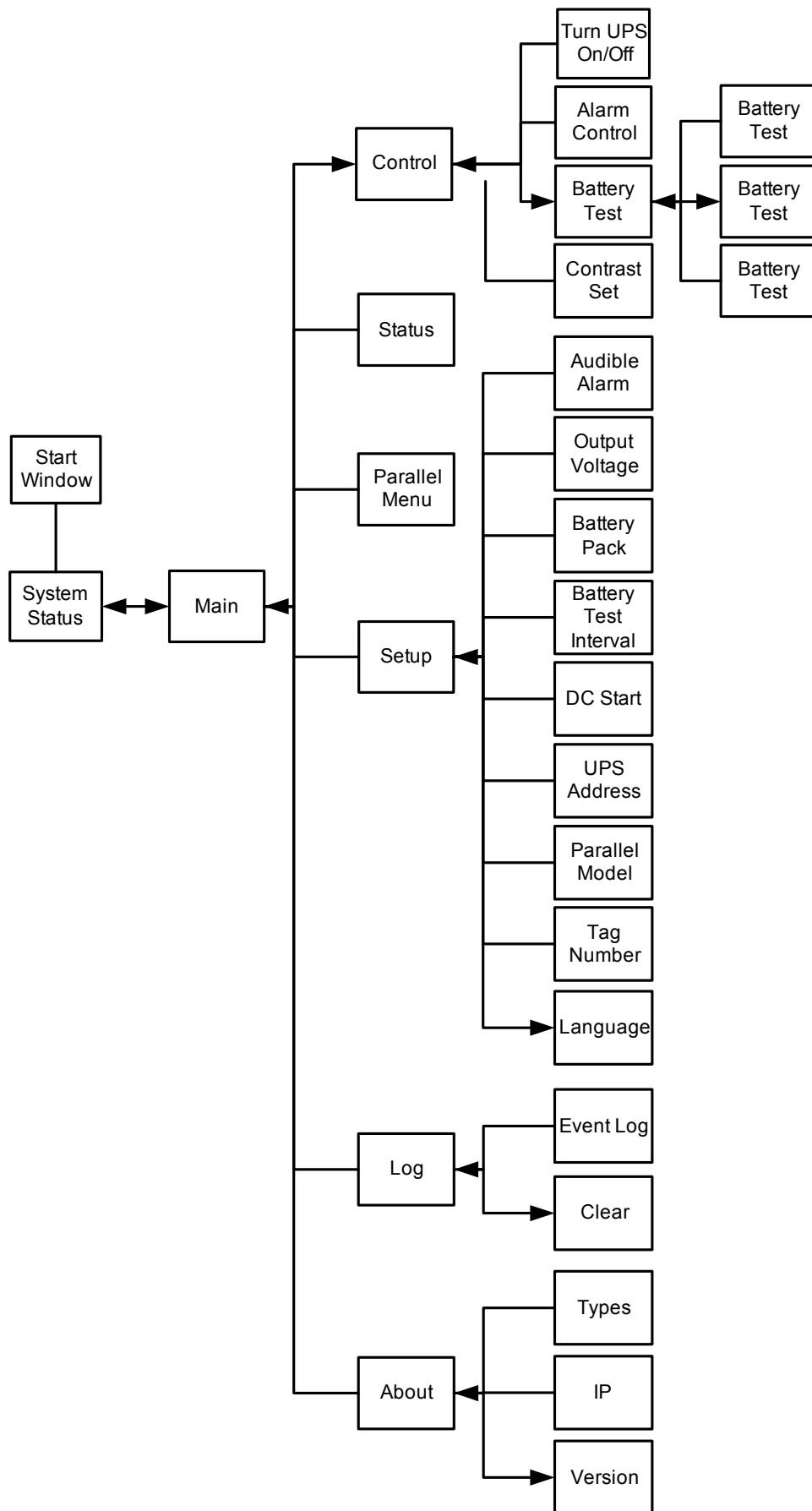

Table 3 Displayed text—system block and main menu

Item # and Name		Description	
Status Menu	Measure value	Unit	
	Output Volt	V	
	Output Freq	0.1Hz	
	Output Current	A	
	Output Watt	W	
	Output VA	VA	
	Output Load	%	
	Input Volt	V	
	L2 Input Volt	N/A	
	L3 Input Volt	N/A	
	Input Freq	0.1Hz	
	Back Voltage	V	
	Batt Capacity	%	
	Backup Time	min:sec	
	Run Time	day:hr:min:sec	
	Tag Number		
Setup Menu	Setting item		Setting (level 1)
		Audible alarm	Disable/Enable
		Output voltage	208/220/230/240V
		Battery pack	1-3 ¹
		Battery Test interval	
		DC start	Disable/Enable
		Tag Number	00000-99999
		Language	English/French/Spanish/German/Italian/ Russian
Logging Menu		Event and time *	
		Clear event log	
	* : Max 4 fault event record		
Firmware Version	Type of UPS	Liebert GXT 10KVA	Liebert® GXT3-10000T220™ Capacity 10KVA
	Internet IP	Web: www.liebert.com	
	Software version	Display Firmware version	DSP Firmware version
Start Window		10kVA UPS Self testing please wait	
		Wait about 6 sec	
Main Menu		Control	
		Status	
		Setup	
		Log	
		About	

Table 3 Displayed text—system block and main menu (continued)

Item # and Name		Description	
Control Menu		Turn UPS ON/OFF	Turn UPS to ONLINE
			Turn UPS to BYPASS
			Turn UPS to shutdown
			Turn UPS to no output
		Alarm control	Alarm ON
			Alarm OFF
		Batt Test	Batt Test
			Cancel Battery Test
			Battery Test Report
		Contrast	Darker
			Lighter
Battery Test Report	Test in progress	Test to Low-Battery	
	Test OK!	Cancel Battery test	
	Test fail	Battery Test report	
	Test stop by user		
	Test unknown		

1. For setup parameters regarding battery pack quantity, refer to **4.2.2 - Battery Setup Parameters**

4.2.2 Battery Setup Parameters

Table 4 Battery setup parameters

Parameter	Internal Battery (X = Integrated)	Quantity External Battery Cabinets	Quantity 12V Battery Blocks in Sum
1	X	—	20
2	X	1	60
3	X	2	100

4.2.3 Warning Indicators

If a warning indication appears, the UPS continues to operate. The warning message alternates with UPS mode once a second.

The various possible warning indicators are listed in the following table:

Table 5 Warning indicators

Warning	Cause	Corrective steps
1	Batt undervolt.	N/A
2	Utility failure	N/A
4	Over temp. 65	Reduce load

4.2.4 Fault Indicators

If a fault occurs, the UPS automatically switches to BYPASS mode, ONLY in case of a battery disconnect fault will the original operating mode be maintained. The fault message alternates with UPS mode once a second, the red Fault LED illuminates on the control panel and the buzzer sounds continuously. If a fault occurs, proceed as follows:

Buzzer alarm operation—The buzzer alarm can be switched On or Off.

Clear fault—Present fault condition can be reset if fault condition is cleared, either automatically or by the operator/technician.

Fault information—A maximum of 4 fault events may be displayed in this window. All fault displays include: the nature of the fault event, and the time it occurred; the time is relative to the UPS operating time.

Display faults—The various possible fault indicators are listed in the following table.

Table 6 Fault indicators

Fault	Cause	Corrective steps
1.	DC BUS fault	Call customer service
2.	Inverter fault	Call customer service
3.	Overtemperature	Reduce load
4.	Batt over volt.	Call customer service
5.	Batt. mode overload	Reduce load
6.	Output overload	Reduce load
7.	Output short	Call customer service
8.	Fan lock fault	Call customer service
9.	Batt. Disconnect	Check battery connector
10.	Charger failure	Call customer service
11.	ESD activated	NA
12.	Parallel fault	Call customer service
13.	Internal fault	Call customer service
14.	Output failure	Call customer service

4.3 Initial UPS Startup Procedure

1. Inspect all power connections to ensure they are correct and secure.
2. Open external circuit breakers/fused disconnects to the connected loads.
3. Close all upstream circuit breakers and fused disconnects.
4. Use a voltmeter to verify proper input voltage is present on the UPS and Bypass input terminals. See **Table 9** for the range.
5. Close the input breakers on the rear panel of the UPS (UPS input and Bypass input).
6. Turn the Maintenance Bypass Breaker to the Bypass position (remove the cover plate if attached).
7. Use a voltmeter to verify that the proper output voltage is present on the UPS output terminals. See **Table 9** for the range.
8. Turn the Maintenance Bypass Breaker to the Off position and reinstall the cover plate..



NOTE

The maintenance bypass breaker cover must be installed behind the captive screw and the screw must be tightened for the UPS to operate on inverter mode.

9. Use a voltmeter to verify the output voltage is NOT present on UPS output terminals.
10. Use the LCD display and control buttons to start the UPS, refer to **4.2.1 - Controls and Messages**.
11. Use a voltmeter to verify proper output voltage is present on UPS output terminals. See **Table 9** for range.



CAUTION

Before reinstalling the hardwire terminal protective panel, follow the shutdown procedure in **4.4 - UPS Shutdown Procedure**

12. Open all upstream circuit breakers and fused disconnects.
13. Reinstall the hardwire terminal protective panel.

4.4 UPS Shutdown Procedure



NOTE

Carrying out this procedure will interrupt the supply to the load.

1. Press the Menu button, select Control and press the Enter key ↵.
2. Select Turn UPS On/Off and press the Enter key ↵.
The LCD displays *Turn UPS to BYPASS*.
3. Press the Enter key ↵ to switch off the inverter.
4. Open any external circuit breakers/fused disconnects connecting the load (if present).
5. Switch both Input circuit breakers to the Off position.
6. Ensure all circuit breakers/fused disconnects upstream of the UPS are open.
7. Ensure that all LEDs on the control panel are extinguished.

The UPS is now completely shut down.

4.5 Maintenance Bypass Procedure

1. Press the Menu button, select Control and press the Enter key ↵.
2. Select Turn UPS On/Off and press the Enter key ↵.
The LCD displays *Turn UPS to BYPASS*. The UPS is now on Internal Bypass Mode.
3. Press the Enter key ↵ to switch off the inverter (see **Figure 10**).
4. Remove the safety cover from the Maintenance Bypass Breaker and turn UPS to BYPASS.



NOTE

At this point the load is no longer protected against interruptions and disturbances on the utility supply.

The UPS is now in Maintenance Bypass Mode. The Bypass LED on the front panel is illuminated (amber) and the load is supplied directly from the utility.

4.6 Return from Maintenance Bypass

1. Ensure all switches and circuit breakers upstream of the UPS are closed.
2. Ensure that both input circuit breakers are in the On position.
3. Turn the Maintenance breaker from BYPASS to UPS and replace the cover.
The load now is supplied via electronic bypass.
4. Press the Menu button, select Control and press the Enter key ↵.
5. Select Turn UPS On/Off and press the Enter key ↵.
The LCD displays *Turn UPS to ONLINE*.
6. Press the Enter key ↵ to switch on the inverter.

The UPS is now in online operation.

4.7 Maintenance Breaker, Off Position

- Move the breaker to the Off position to transfer the load from the UPS to utility.



WARNING

The output breaker on this unit does not protect every output configuration. Power to the load could be supplied immediately when the output is enabled. (Figure 9 illustrates the location of the output breaker in the output configuration.)

4.8 Self-Tests

4.8.1 Lamp Test



NOTE

This test involves putting the Liebert® GXT3-10000T220™ into bypass mode. The load is not protected against any utility disturbances or interruptions while the UPS is in bypass mode.

1. With the Liebert GXT3-10000T220 connected to the utility, press the Menu button, select Control and press OK.
2. Select Turn UPS On/Off and press OK.
3. The LCD will show *Turn UPS to BYPASS*.
4. Press OK to off the inverter to Bypass mode.
5. A single acoustic signal confirms the operation.
6. Select Turn UPS On/Off and press OK to place the UPS back in Normal Mode operation. The UPS performs the test during Start-up.

4.8.2 Battery Test



NOTE

During the test an acoustic signal will be heard as though the device is operating in battery mode.

1. Press the Menu button.
2. Select SETUP and press OK.
3. Select BATT TEST and press OK.

A single acoustic signal confirms the operation and the load will be supplied by the battery.

If the test is successful, the BATT LED will stop flashing and the UPS will return to Line mode. If the UPS circuitry detects a battery malfunction, Liebert GXT3-10000T220 will display an alarm (see 4.2.1 - Controls and Messages).

5.0 MAINTENANCE

5.1 Test, Replacement and Disposal of Batteries

The Liebert® GXT3™ is designed to allow the user to replace the internal battery pack safely. Refer to **Table 7** for internal battery pack part numbers for Liebert GXT3 UPS and Liebert External Battery Cabinets:

Table 7 Replacement battery pack

Unit Type and Model #	Replacement Internal Battery Pack Model Number	Quantity Required
Liebert UPS GXT3-10000T220	GXT3-240BATAKIT	2
Liebert External Battery Cabinet GXT3-240VBATTCE	GXT3-240BATAKIT	2

Read all safety cautions before proceeding. Contact your local dealer or Emerson representative to obtain the part number and pricing of the appropriate replacement battery pack.

Disposal of the UPS and batteries should be carried out by a certified disposal company—observe all local regulations and laws. Lead-acid batteries are classified as harmful toxic waste and as such the law demands that they be disposed of by an authorized recycling centre.

The typical battery lifecycle is 3 to 5 years at an ambient temperature of 25 C, but is also dependent on the frequency and duration of utility failures.

The BATTERY TEST (see **4.8.2 - Battery Test**) should be run periodically (6 to 12 months) to ascertain the general condition of the batteries and ensure maximum run time.

5.2 Storage

For extended storage at ambient temperatures cooler than 25°C (77°F), the batteries should be charged for 24 hours once every six months.

Connect the UPS to a utility outlet socket having a ground (earth) connection and ensure the miniature circuit breaker is closed. If charging batteries with fixed utility connections, make connections in accordance with **3.0 - Installation**.

After 24 hours, disconnect the UPS from the utility supply.

5.3 Cleaning

The UPS may be cleaned by wiping it off with a dry cloth. Do not use liquids or solvents.

6.0 COMMUNICATION

6.1 Communication Interface Port

The Liebert® GXT3™ UPS has a terminal block on the rear of the UPS unit. Several signals are provided on this port and are assigned as follows.

6.2 Dry Contact

The Dry Contact includes eight pins, as shown and defined in **Figure 12**.

Figure 12 Dry contact pin layout

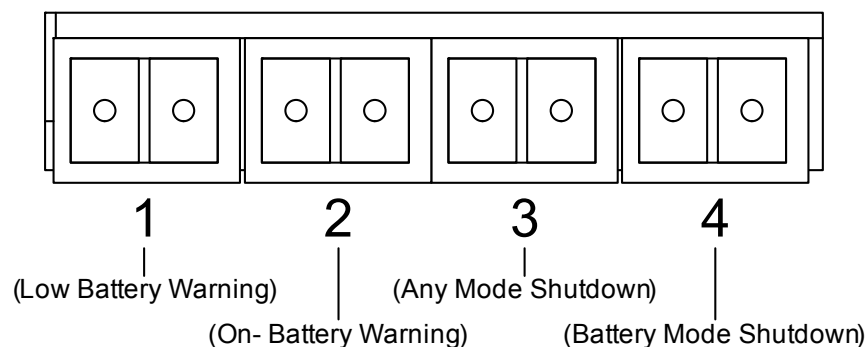

6.2.1 Any Mode Shutdown

The purpose of Any Mode Shutdown is to shut down the UPS output by turning Off the rectifier, inverter and static switch so that there is no power to the loads.

Any Mode Shutdown can be operated locally or remotely:

- Local Any Mode Shutdown can be performed by shorting the pins in Set 3.
- Remote Any Mode Shutdown can be performed using a switch connected to the pins in Set 3 and mounted at a remote location.

Activation of the Any Mode Shutdown will be logged as an event in the event history log.



NOTE

Remote Power Off will be performed either by NO or NC contact of Any Mode Shutdown.

The current limited source (+12VDC, 50mA) will be available from UPS.

The connection to UPS for remote connection will be via terminal block connector.

Any Mode Shutdown wiring must conform to all national, regional and local wiring codes and laws.



WARNING

When the Auto-enable output option is selected and the UPS output is disabled using the pins in Set 3, the Liebert GXT3-G's output can turn On automatically and without warning if the connection of the pins in Set 3 is changed.

6.2.2 Battery Mode Shutdown

Battery Mode Shutdown permits shutting down the UPS by turning off the rectifier, inverter and static switch so that there is no power to the load when the UPS is On Battery. The auxiliary power for the UPS will still be active.

Battery Mode Shutdown can be performed locally or remotely:

- Local Battery Mode shutdown can be performed by shorting the pins in Set 4.
- Remote Battery Mode Shutdown can be performed using a switch connected to the pins in Set 4 and mounted at remote location.

Activation of the Battery Mode Shutdown will be logged as an event in the event history log.



NOTE

Remote Power Off will be performed by NO contact.

The current limited source (+12VDC, 50mA) will be available from UPS.

The connection to the Liebert® GXT3™ for remote connection will be via terminal block connector.

Battery Mode Shutdown wiring must conform to all national, regional and local wiring codes and laws.

This signal must last for 1.5 seconds or longer.

A battery shutdown signal will not cause an immediate shutdown. It will start a 2-minute shutdown timer. This timer cannot be stopped once triggered. If the utility power returns during this countdown, the Liebert GXT3 will still shut down and must remain shut down for 10 seconds. Whether the UPS turns back On when the power is restored depends on the auto-restart setting.

6.2.3 On Battery

On Battery signal is a Normally Open (NO) dry contact. When the UPS is supplying output power from the battery this dry contact will be closed.

6.2.4 Low Battery

Low Battery signal is a Normally Open (NO) dry contact. When the UPS is supplying output power from the battery and has reached the Low Battery Warning time selected in the configuration program, this dry contact will be closed.



NOTE

The rated values for the dry contacts are:

- *Rated Voltage: 30V (AC or DC)*
- *Rated Current: 300mA*

6.3 Liebert IntelliSlot® Communication Cards

The Liebert IntelliSlot port accepts three optional cards:

- Liebert IntelliSlot SNMP Card
- Liebert IntelliSlot Relay Card
- Liebert IntelliSlot 485 Card.

The Liebert IntelliSlot SNMP Card provides SNMP monitoring and control of the UPS across the network.

The Liebert IntelliSlot Relay Card provides dry contact relay outputs for custom-wired applications and delivers support for built-in shutdown for AS/400 systems.

The Liebert IntelliSlot 485 Card is used to connect the UPS and computer system.

Follow instructions provided with the Liebert IntelliSlot card to configure Liebert MultiLink®, the UPS or any additional ancillary product for the Liebert GXT3. These instructions are available at

multilink.liebert.com

6.3.1 Liebert® MultiLink®

Liebert MultiLink continually monitors the UPS and can shut down your computer or server in the event of an extended power failure.

Liebert MultiLink can also be configured for use without the USB cable when the Liebert IntelliSlot® SNMP/Web card is installed in the UPS. Additionally, Liebert MultiLink can be configured to coordinate shutdown across the network with other computers running Liebert MultiLink when you purchase a Liebert MultiLink License Kit. For more information about the Liebert IntelliSlot SNMP/Web Card and Liebert MultiLink License Kits, visit our Web site (www.liebert.com) or contact your local dealer or Emerson representative.

Several option cards are available for use in the Liebert IntelliSlot port of the Liebert GXT3™. The Liebert IntelliSlot SNMP/Web Card provides SNMP and Web-based monitoring and control of the UPS across the network.

The Liebert IntelliSlot MultiPort 4 Card allows installing Liebert MultiLink software on four computers and coordinate shutdown in the event of a power failure.

The Liebert IntelliSlot Relay Card provides dry contact relay outputs for custom wired applications and delivers support for built-in shutdown for AS/400 systems.



CAUTION

To maintain safety (SELV) barriers and for electromagnetic compatibility, signal cables should be shielded and run separate from all other power cables, where applicable.

6.4 Remote Emergency Power Off

The UPS is equipped with a Remote Emergency Power Off (REPO) connector.

The user must supply a means of interfacing with the REPO circuit to allow disconnecting the UPS input feeder breaker to remove all sources of power to the UPS and connected equipment to comply with national and local wiring codes and regulations.

REPO switch connection diagram

UPS ships with REPO jumper installed allowing the UPS to operate

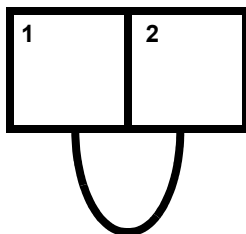

Normally closed switch system
(fail-safe)

Opening the REPO connection will disable the UPS. Manual restart using the front panel is required after the REPO connection is closed again.

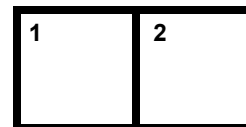

CAUTION

To maintain safety (SELV) barriers and electromagnetic compatibility, signal cables should be shielded and run separately from power cables.

7.0 TROUBLESHOOTING

If any technical problems should occur, check the following before contacting Liebert® technical support:

- Is the utility voltage present at the UPS input?
- Has the input fuse blown or have the circuit breakers tripped?
- Has the UPS startup procedure been followed correctly?

When contacting Liebert technical support, have the following information available:

- Device model number
- Serial number (from the nameplate)
- Exact description of the problem (what loads are being operated, does the problem occur regularly or sporadically, etc.)

For descriptions of the indicators mentioned in the following table, see **4.2.1 - Controls and Messages**.

Table 8 Troubleshooting guide

Problem	Possible Cause	Solution
No display No alarm (UPS switched Off)	Utility mains switched off	Switch on utility breaker
	No mains voltage present	Have utility mains inspected by a qualified technician
	Input fuse blown or input circuit breaker tripped	Replace with fuse of same type or switch on circuit breaker. If the problem persists, contact technical support.
UPS on LED does not light up, alarm beeps sound at intervals	No utility mains voltage present	Have utility mains inspected by a qualified technician
UPS on LED does not illuminate when utility mains voltage present, acoustic alarm active at intervals	Input fuse defective or input circuit breaker tripped	Replace with fuse of same type or switch on circuit breaker. If the problem persists, contact technical support
FAULT LED illuminates, alarm sounding constantly	UPS error	Contact technical support
	Overheating	Decrease ambient temperature
Battery Run time less than specified	The battery breaker is open, in the OFF position	Move the battery breaker to the ON position
	Batteries are not fully charged	Charge batteries (see Battery Test on page 19) and test backup time. If the problem persists, contact technical support.
	Batteries are defective	Contact technical support
	Charging device is defective	Contact technical support
OVERLOAD message displayed	Overload at UPS output	Reduce load to the permissible value
No communication between UPS and PC	Wrong serial connection cable	Check whether the correct cable has been used (standard modem/null modem cables are not permissible)
	Interface on the PC is being used by another process or is defective	Check whether other software/service is accessing the interface on the PC; try selecting a different serial interface
	Interference on the data cable	Lay cable differently/Reinstall cabling

8.0 SPECIFICATIONS

Table 9 Liebert® GXT3™ specifications

Model Rating, VA (W)	10,000 (9000)
Dimensions, in. (mm)	
Unit, W x D x H	31.5 x 11.81 x 26.57 (800 x 300 x 675)
Shipping, W x D x H	41.8 x 16.7 x 34 (1062 x 426 x 866)
Weight, lb (kg)	
Unit	308 (140)
Shipping	428 (194)
Input AC Parameters	
Nominal Operating Frequency	50 or 60Hz (Factory Default = 60)
Factory Default VAC	120/208 at 120 degrees
User-Configurable VAC	120 / 208 / 220 / 240
Operating Voltage Range Without Battery Operation	100 - 185 \pm 5VAC
Maximum Allowable VAC	280
Input Frequency Without Battery Operation	40 - 70Hz
Input Power Connection	BYP, L1, L2, GND
Output AC Parameters	
Factory Default, VAC	208
Output Connections	Hardwire Terminal Block Output: (GEC, X1, X2, X3, X4, GND) Bypass: L1, L2, GND
Frequency	50Hz or 60Hz, Nominal
Waveform	Sinewave
Main Mode Overload	>200% for 5 cycles; 151 - 200% for 1 second; 131-150% 10 seconds; 105 - 130% 1 minute
Battery Parameters	
Type	Valve-regulated, non-spillable, lead acid
Quantity x V	20 x 12V
Battery Mfr. / Part #	CSB HR1234R or Panasonic UP-RW1245
Backup Time	See Table 11
Recharge Time (Internal Batteries)	3 hr. to 90% capacity after full discharge into 100% load
Bypass Protection Limits	
Maximum Bypass Current	50A
Disable Bypass Operation	If input voltage exceeds \pm 10% of the nominal voltage
Re-Enable Bypass Operation	If input voltage returns to within \pm 8% of nominal output voltage
Disable Bypass Operation	When the input frequency prevents synchronous operation
Environmental	
Operating Temperature, °F (°C)	32 to 86 (0 to 30) with 0.9 pf 86 to 104 (30 to 40) with 0.8pf
Storage Temperature, °F (°C)	5 to 122 (-15 to 50)
Transportation, °F (°C)	
Relative Humidity	0-95% non-condensing
Operating Elevation	Up to 3281 ft (1000m) at 80°F (27°C) without derating
Audible Noise	<55 dBA at 3.3ft (1m) from rear; <50 dBA at 3.3ft (1m) from front or sides
Agency	
Safety	UL 1778, c-UL
RFI/EMI	FCC Part 15, Subpart B, Class A
Surge Immunity	IEC/EN 61000-4-5, ANSI C62.41 (for North America)
Transportation	ISTA Procedure 1B

Table 10 Battery cabinet specifications

Model Number	GXT3-240TBATTCE	
Dimensions, W x D x H, in. (mm)		
Unit	31.5 x 11.81 x 26.57 (800 x 300 x 675)	
Shipping	41.8 x 16.7 x 34 (1062 x 426 x 866)	
Weight, lb (kg)		
Unit	243 (110)	
Shipping	309 (140)	
Internal Battery Parameters		
Type	Valve-regulated, non-spillable, lead acid	
Quantity x V	2 x 20 x 12V	
Battery Manufacturer, Part #	CSB HR1234R or Panasonic UP-RW1245	
Temperature Limits, Batteries Only, °F (°C)	32 to 104 (0 to 40)	
Backup Time	See Table 11	
Environmental		
Operating Temp, °F (°C)	32 to 80 (0 to 27)	
Storage Temp	5 to 104 (-15 to 40)	
Transportation Temp, °F (°C)	5 to 122 (-15 to 50)	
Relative Humidity	0-95% non-condensing	
Operating Elevation	Up to 3281 ft (1000m) at 80°F (27°C) without derating	
Agency		
Safety	UL 1778, c-UL Listed	
Transportation	ISTA Procedure 1B	

Table 11 Typical battery run times for the Liebert® GXT3-10000T230™

Number of Batteries, Battery Cabinets	Load %									
	10%	20%	30%	40%	50%	60%	70%	80%	90%	100%
Internal Battery	81	39	22	15	11	8	6	5	4	3
Internal Battery + 1 External Battery Cabinet	190	127	81	60	46	39	32	26	22	18
Internal Battery + 2 External Battery Cabinets	316	162	136	106	82	69	52	48	44	39

Approximate discharge times are at 77°F (25°C) with a 100% resistive load.

9.0 PRODUCT WARRANTY REGISTRATION

To register for warranty protection:

- Visit the Quick Links section of Liebert's Web site at:
<http://www.liebert.com>
- Click on **Product Warranty Registration** and fill in the form.

If you have any questions, please contact us at:

- US: 800-222-5877
- Outside the US: 614-841-6755
liebert.upstech@emerson.com

Ensuring The High Availability Of Mission-Critical Data And Applications.

Emerson Network Power, a business of Emerson (NYSE:EMR), is the global leader in enabling *Business-Critical Continuity™* from grid to chip for telecommunication networks, data centers, health care and industrial facilities. Emerson Network Power provides innovative solutions and expertise in areas including AC and DC power and precision cooling systems, embedded computing and power, integrated racks and enclosures, power switching and controls, infrastructure management, and connectivity. All solutions are supported globally by local Emerson Network Power service technicians. Liebert AC power, precision cooling and monitoring products and services from Emerson Network Power deliver Efficiency Without Compromise™ by helping customers optimize their data center infrastructure to reduce costs and deliver high availability.

While every precaution has been taken to ensure the accuracy and completeness of this literature, Liebert Corporation assumes no responsibility and disclaims all liability for damages resulting from use of this information or for any errors or omissions.

© 2010 Liebert Corporation

All rights reserved throughout the world. Specifications subject to change without notice.

® Liebert is a registered trademark of Liebert Corporation.

All names referred to are trademarks or registered trademarks of their respective owners.

SL-23187_REV1_04-12

Technical Support / Service

Web Site

www.liebert.com

Monitoring

liebert.monitoring@emerson.com

800-222-5877

Outside North America: +00800 1155 4499

Single-Phase UPS & Server Cabinets

liebert.upstech@emerson.com

800-222-5877

Outside North America: +00800 1155 4499

Three-Phase UPS & Power Systems

800-543-2378

Outside North America: 614-841-6598

Environmental Systems

800-543-2778

Outside the United States: 614-888-0246

Locations

United States

1050 Dearborn Drive

P.O. Box 29186

Columbus, OH 43229

Europe

Via Leonardo Da Vinci 8

Zona Industriale Tognana

35028 Piove Di Sacco (PD) Italy

+39 049 9719 111

Fax: +39 049 5841 257

Asia

29/F, The Orient Square Building

F. Ortigas Jr. Road, Ortigas Center

Pasig City 1605

Philippines

+63 2 687 6615

Fax: +63 2 730 9572

Emerson Network Power.

The global leader in enabling *Business-Critical Continuity™*

- | | | | |
|----------------|--|------------------------------|-------------------------------|
| ■ AC Power | ■ Embedded Computing | ■ Outside Plant | ■ Racks & Integrated Cabinets |
| ■ Connectivity | ■ Embedded Power | ■ Power Switching & Controls | ■ Services |
| ■ DC Power | ■ Infrastructure Management & Monitoring | ■ Precision Cooling | ■ Surge Protection |