

\$1.00

OWNER'S GUIDE

ASSEMBLY • OPERATION • MAINTENANCE • PARTS

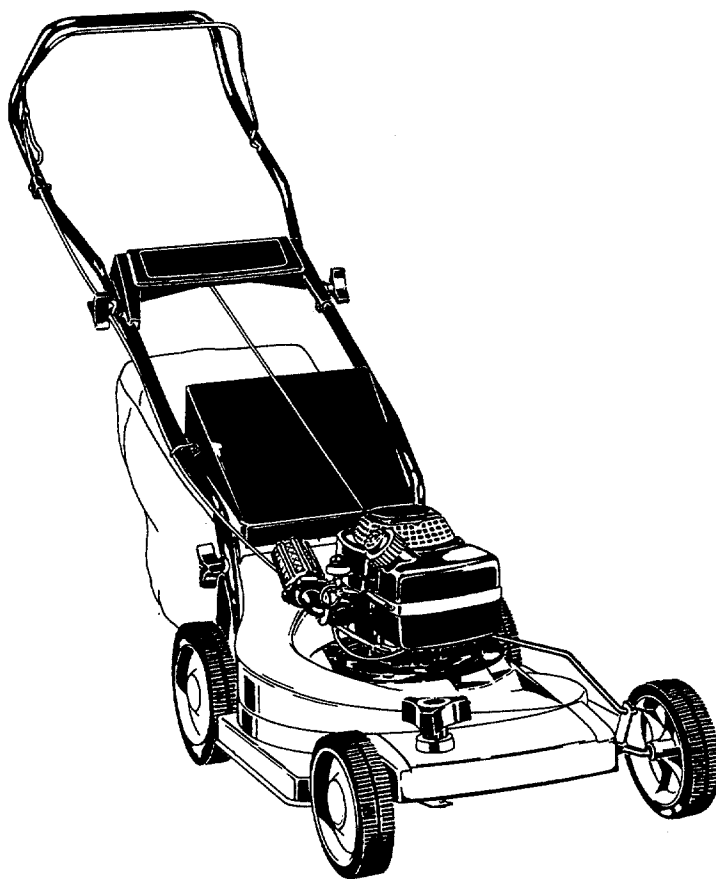

16"
ROTARY
MOWER

Model Number
110-127R000

Important: Read Safety Rules and Instructions Carefully

INDEX

Slope Gauge	3
Contents of Hardware Pack	4
Safety Rules	5
Assembly	6
Operation	7
Maintenance	9
Service and Adjustments	10
Storage	11
Service Recommendations	12
Trouble Shooting	13
Replacement Parts	14, 15
Parts Information	Back Cover

Dear Customer,

So often throughout the year we are all in a rush to meet our daily obligations.

However, we at MTD Products Inc are taking a quick moment out to say...

"Thank you for your business."

Sincerely,
MTD PRODUCTS INC



INSTRUCTIONS GIVEN WITH THIS SYMBOL ARE FOR PERSONAL SAFETY. BE SURE TO FOLLOW THEM.

The use of any accessory on this Rotary Mower other than those manufactured by the mower manufacturer is **not** recommended.



WARNING: DO NOT operate the mower without the entire grass catcher or chute deflector in place. DO NOT operate the mower without the protective shield on the rear of the deck in place.

NOTE: Under normal usage bag material is subject to wear and should be checked periodically. Be sure any replacement bag complies with the mower manufacturer's recommendations. For replacement bags, use only factory authorized replacement bag.

WARNING: This unit is equipped with an internal combustion engine and should not be used on or near any unimproved forest-covered, brush-covered or grass-covered land unless the engine's exhaust system is equipped with a spark arrester meeting applicable local or state laws (if any). If a spark arrester is used, it should be maintained in effective working order by the operator.

In the State of California the above is required by law (Section 4442 of the California Public Resources Code). Other states may have similar laws. Federal laws apply on federal lands. A spark arrester for the muffler is available through your nearest engine authorized service dealer.

USE THIS SHEET AS A GUIDE TO DETERMINE SLOPES WHERE YOU MAY NOT OPERATE SAFELY.

SLOPE GAUGE

(Keep this sheet in a safe place for future reference.)

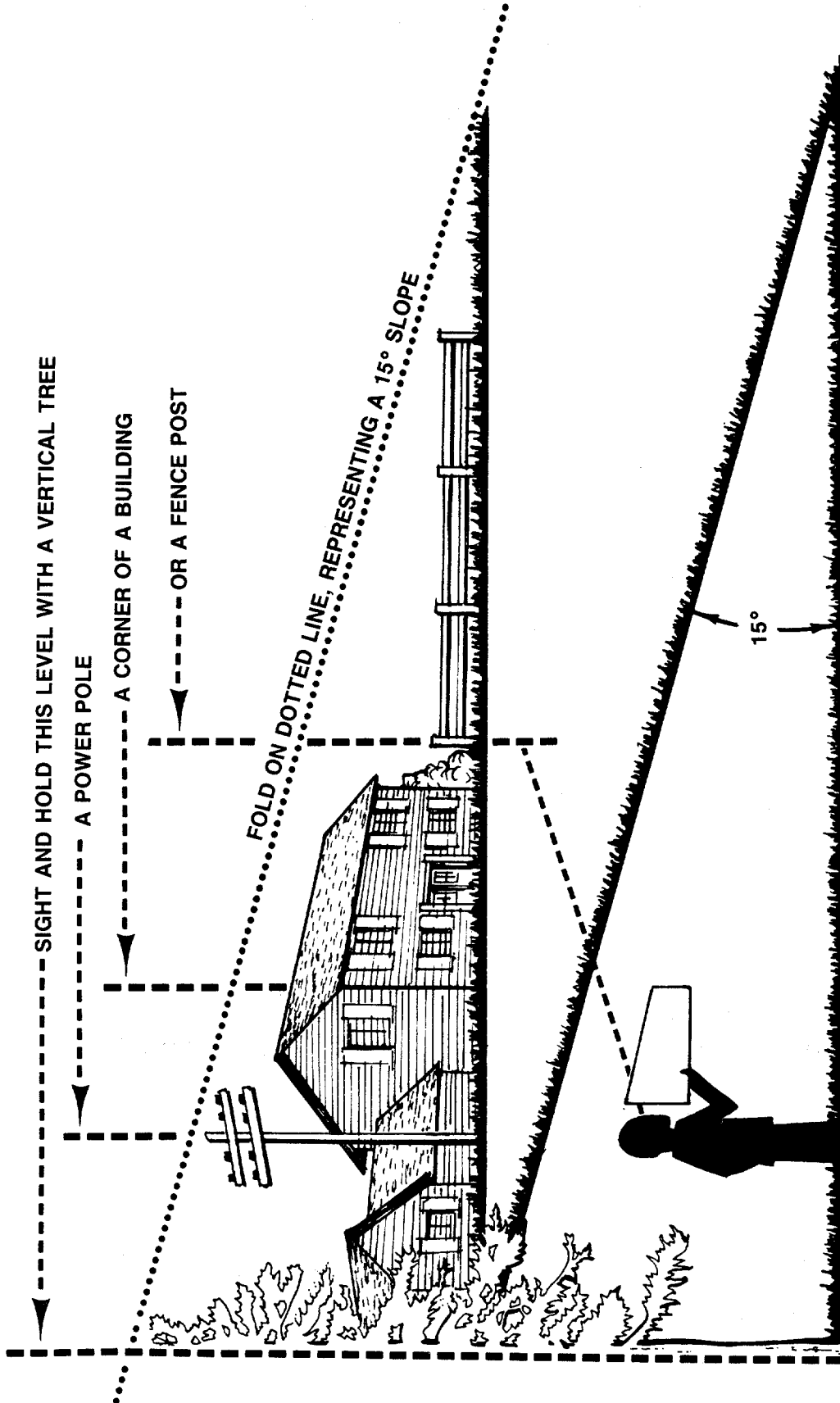

Do not mow on inclines with a slope in excess of 15 degrees (a rise of approximately 2½ feet every 10 feet). A riding mower could overturn and cause serious injury. If operating a walk-behind mower on such a slope, it is extremely difficult to maintain your footing and you could slip, resulting in serious injury.

Operate RIDING mowers up and down slopes, never across the face of slopes.

Operate WALK-BEHIND mowers across the face of slopes, never up and down slopes.

Remove this sheet from your owner's manual and lay the hardware on the illustration for identification purposes. After assembly, keep the Slope Gauge which is on the reverse side of this sheet for future use.

HARDWARE PACK CONTENTS

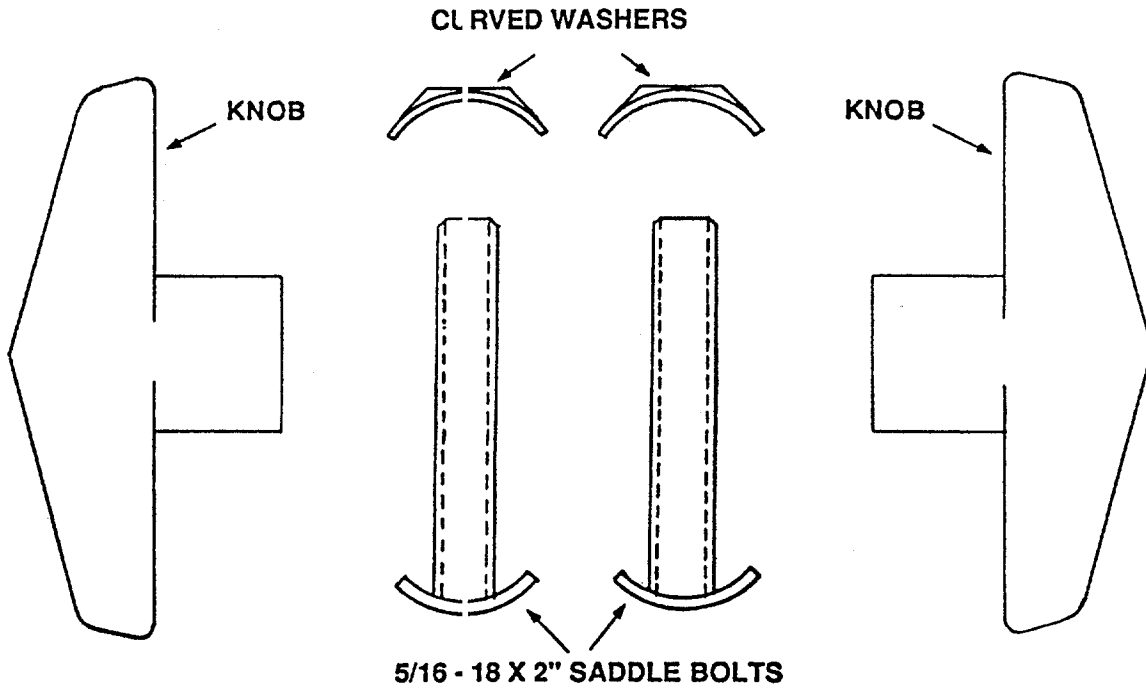

#10 SHEET METAL SCREWS

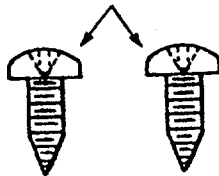

PLASTIC CABLE TIE



Cut A

This Line

SAFETY RULES



CAUTION: ALWAYS DISCONNECT SPARK PLUG WIRE AND PLACE WIRE WHERE IT CANNOT CONTACT SPARK PLUG TO PREVENT ACCIDENTAL STARTING WHEN SETTING-UP, TRANSPORTING, ADJUSTING OR MAKING REPAIRS TO YOUR MOWER.



IMPORTANT

FEDERAL REGULATIONS REQUIRE OPERATOR PRESENCE BLADE STOP CONTROLS TO MINIMIZE THE RISK OF CONTACT INJURY. YOUR MOWER IS EQUIPPED WITH SUCH CONTROLS. DO NOT ATTEMPT TO DEFEAT THE FUNCTION OF THE OPERATOR PRESENCE CONTROL UNDER ANY CIRCUMSTANCES.

TRAINING:

- Read the owner's manual carefully. Become familiar with the controls and know how to operate this mower properly. Learn how to stop the mower quickly.
- DO NOT allow children to use this mower. Never allow adults to use the mower without proper instructions.
- Keep the area of operation clear of all persons, especially small children and pets.
- Use the mower only as the manufacturer intended and as described in this manual.
- When not using your mower, store it indoors in a dry, high or locked-up place - out of reach of children.
- DO NOT operate mower if it has been dropped or damaged in any manner. Always have damage repaired before using the mower.
- DO NOT use accessory attachments not recommended by the manufacturer - it may be hazardous.

PREPARATION:

- Objects struck by the lawn mower will be thrown and can cause severe injury to persons. Always check the area to be mowed and clear it of all stones, sticks, wires, bones, etc.
- Dress properly - Wear only solid shoes when mowing. Never mow when barefoot or wearing open sandals.
- Always wear safety glasses or eye shields when starting and while using your lawn mower.
- DO NOT fill gas tank when the engine is running, indoors or when engine is hot. Allow the engine to cool for several minutes before filling the gas tank. Clean off any spilled gasoline before starting the engine.
- Never make wheel height adjustments while the engine is running.
- Mow only in daylight or good artificial light.
- DO NOT operate mower in wet grass. Always be sure of your footing - keep a firm hold on the handles and walk-never run.

OPERATION:

- DO NOT change the governor settings or overspeed the engine.
- DO NOT put hands or feet near or under rotating parts. Keep clear of the discharge opening at all times.

- Stop the engine whenever you leave the mower, before crossing drives, walks or roads.
- DO NOT continue to run your mower if you hit a foreign object. Stop the engine, make absolutely sure the blade and all moving parts have stopped, disconnect the spark plug wire from the spark plug to prevent accidental starting, then inspect the mower for damage and repair before restarting and operating the mower.
- If mower should start to vibrate heavily, stop the engine, check for the cause and repair. Remember, heavy vibration is generally a sign of trouble.
- Stop the engine, wait for blade and all moving parts to stop, before cleaning, unclogging chute, removing grass catcher, repairing or inspecting the mower. Always disconnect the spark plug wire and keep away from plug to prevent accidental starting.
- DO NOT run engine indoors - exhaust fumes are dangerous.
- Never cut grass by pulling the mower towards you. Mow grass across the face of slopes, never up and down or you could lose your footing. DO NOT mow excessively steep slopes. Use caution when operating the mower on uneven terrain or when changing direction - maintain good footing.
- Never operate the mower without proper guards, plates or other safety devices in place.

MAINTENANCE AND STORAGE:

- Check the blade and the engine mounting bolts often to be sure they are tightened properly.
- Check all bolts, nuts and screws at frequent intervals for proper tightness to be sure mower is in safe working condition.
- Never store mower with fuel in the tank inside a building where ignition sources are present such as hot water heater and space heaters, clothes dryers, and the like.
- Allow engine to cool before storing in any enclosure.
- To reduce fire hazard, keep the engine free of grass, leaves or excessive grease and oil.
- If grass catcher is used with your mower, check it often for deterioration and wear and replace worn bags. Use only replacement bags that are recommended by and comply with specifications of the manufacturer of your mower.
- Keep a sharp blade on your mower.



LOOK FOR THIS SYMBOL TO POINT OUT IMPORTANT SAFETY PRECAUTIONS. IT MEANS-ATTENTION!!! BECOME ALERT!!! YOUR SAFETY IS INVOLVED.

ASSEMBLY

Your lawn mower has been completely assembled at the factory except for the upper handle, trimplate and grass catcher.

TO REMOVE MOWER FROM CARTON

- Remove loose parts if included with mower, (i.e. trimplate and hardware pack, etc.).
- Cut down corners on one end of carton and lay end down flat.
- Remove packing material.
- Roll mower out of carton and check carton thoroughly for loose parts.

HOW TO SET-UP YOUR LAWN MOWER

ATTACH UPPER HANDLE (See Fig. 1)

- Unfold lower handle rearward into operating position. **BE CAREFUL NOT TO PINCH OR KINK THE ENGINE CONTROL CABLE.** Tighten knob securely on right side of lower handle.
- Position upper handle so operator presence control bar is on top and assemble to lower handle with saddle bolts, curved washers and knobs as shown.
- Tighten knobs securely.
- Secure engine cable to lower handle with plastic tie (See Fig. 5).

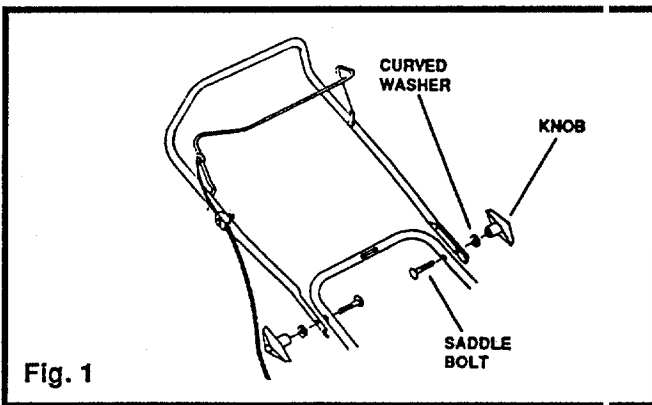

Fig. 1

ATTACH TRIMPLATE (See Fig. 2)

- Attach trimplate to lower handle with two (2) #10 sheet metal screws and tighten securely.

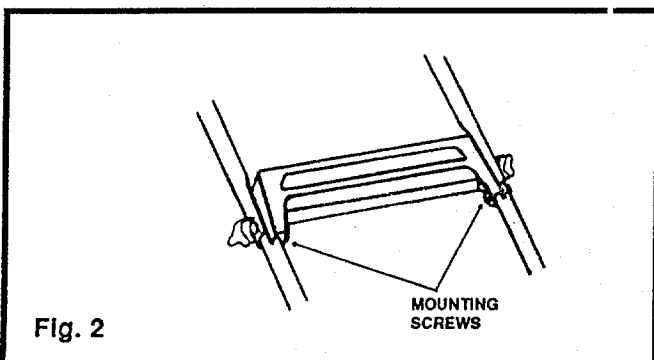

Fig. 2

ASSEMBLE GRASS CATCHER (See Fig. 3)



CAUTION: DO NOT RUN YOUR LAWN MOWER WITHOUT THE CHUTE DOOR OR APPROVED GRASS CATCHER IN PLACE.

- With frame handle upwards, slip frame inside of bag so plastic bag panel is at bottom.
- Snap sleeves around bag opening onto catcher frame as shown.

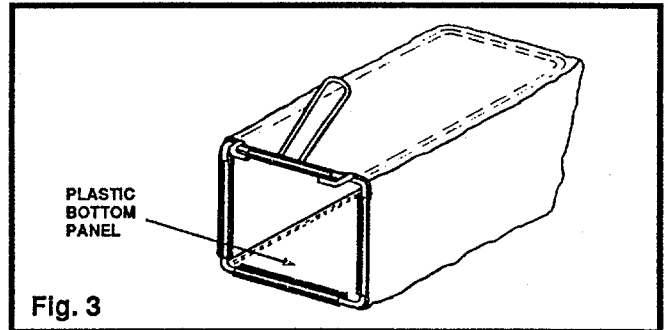

Fig. 3

TO ATTACH GRASS CATCHER (See Fig. 4)

- Place grass catcher on the ground behind the lawn mower.
- Stand on the left side of the mower and open chute door with your left hand.
- With your right hand, reach through lower handle to lift grass catcher and push forward to hook frame onto deck mounting ears.
- After catcher is positioned snugly on mower, release chute door and allow it to rest on catcher handle.

TO REMOVE GRASS CATCHER

- Simply lift up chute door and pull catcher up and away from mower.

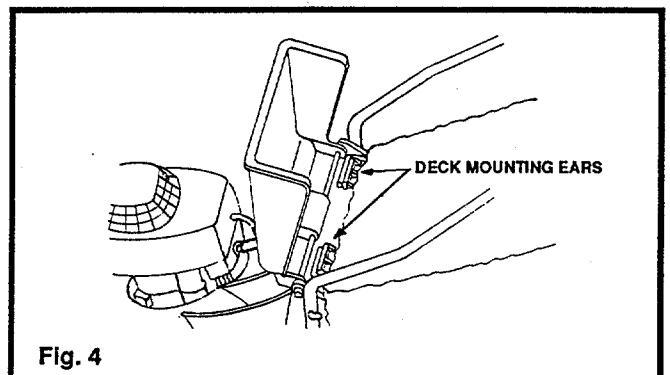

Fig. 4



CAUTION: UNDER NORMAL USAGE, THE CATCHER MATERIAL IS SUBJECT TO DETERIORATION AND WEAR AND SHOULD, THEREFORE, BE CHECKED FREQUENTLY FOR REPLACEMENT. ANY REPLACEMENT CATCHER SHOULD BE CHECKED TO ENSURE COMPLIANCE WITH ORIGINAL MANUFACTURER SPECIFICATIONS.

OPERATION

KNOW YOUR LAWN MOWER

READ THIS OWNER'S MANUAL AND SAFETY RULES BEFORE OPERATING YOUR ROTARY MOWER. Compare the illustrations with your Rotary Mower to familiarize yourself with the location of various controls and adjustments. Save this manual for future reference.

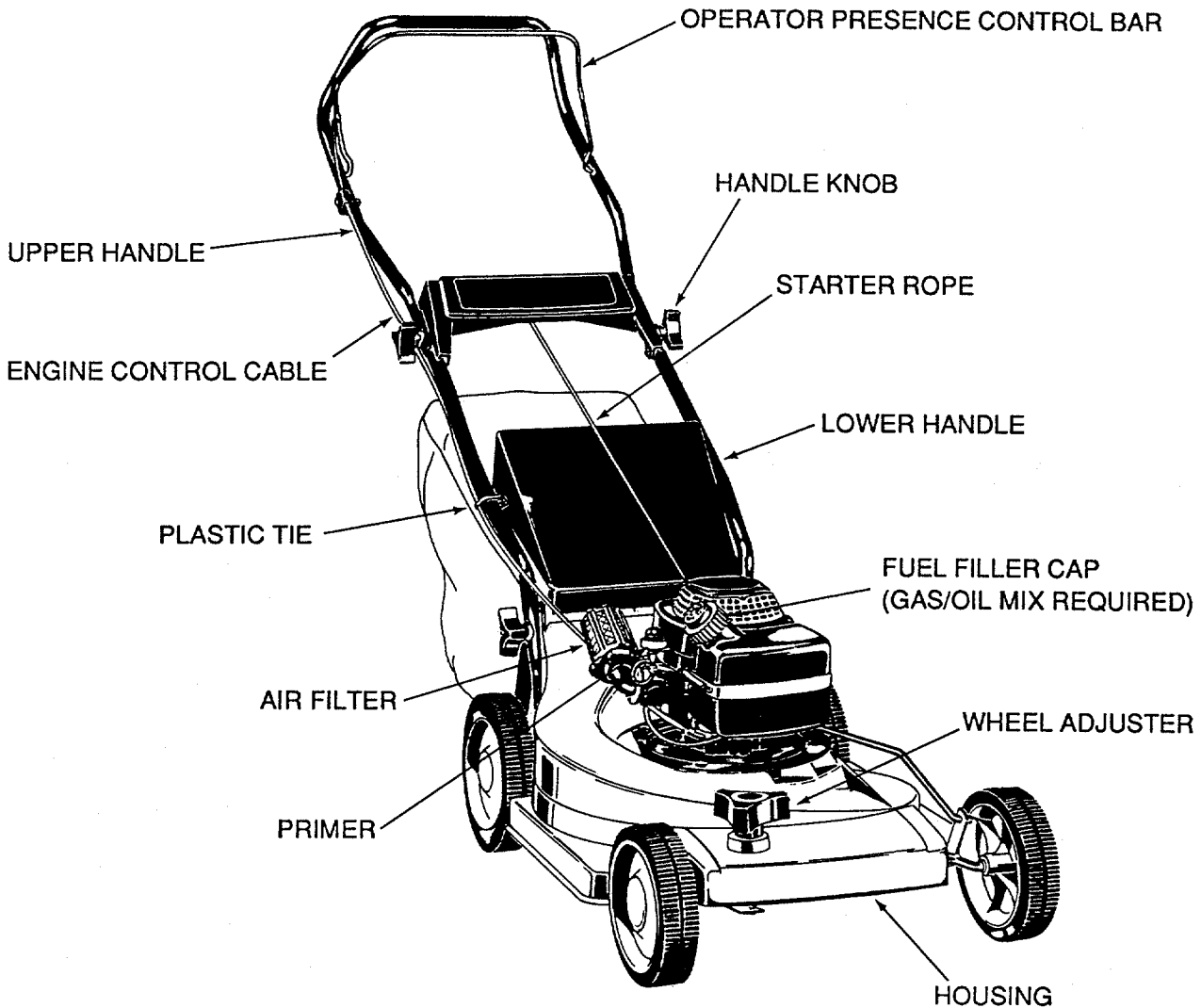

Fig. 5

MEETS CPSC SAFETY REQUIREMENTS

Our Rotary Walk-Behind Power Mowers conform to the safety standards of the American National Standards Institute, and the U.S. Consumer Product Safety Commission. The blade turns when the engine is running.

OPERATOR PRESENCE CONTROL BAR - must be held down to the handle to start and run the engine. Release to stop the engine.

PRIMER - pumps additional fuel from the carburetor to the cylinder for use when starting a cold engine.

STARTER ROPE - used for starting the engine.

OPERATION

BEFORE USING YOUR LAWN MOWER, ALWAYS REFER TO THE "SAFETY RULES" AS SHOWN ON PAGE 5 OF THIS MANUAL. ALWAYS BE CAREFUL



The operation of any Lawn Mower can result in foreign objects being thrown into the eyes, which can result in severe eye damage. Always wear safety glasses or eye shields before starting power tool operation or while performing any adjustments or repairs. We recommend wide vision safety mask for over spectacles or standard glasses available at your nearest distributor.

HOW TO USE YOUR MOWER

OPERATOR PRESENCE CONTROL BAR

Your mower has a control bar which requires the operator to be behind the handle to start and run the mower. When the operator releases the control bar the engine will stop and an internal brake helps the blade to stop quickly.

When the operator leaves the operating position to remove the grass catcher, change the cutting height, pick up sticks or other objects in the way, the engine will stop automatically when the control bar is released.

ADJUST CUTTING HEIGHT (See Fig. 6)

WARNING: TURN OFF ENGINE AND DISCONNECT SPARK PLUG BEFORE ADJUSTING WHEELS.

- Turn "DIAL ADJUST" knob clockwise to lower cutting height and counter clockwise to raise cutting height.

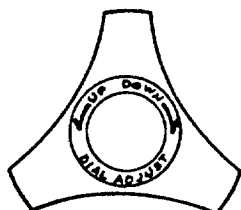

Fig. 6

NOTE: The cutting height range is approximately 7/8" to 3-1/4". The heights are measured from the ground to the blade tip with the engine not running. These heights are approximate and may vary depending upon soil conditions, height of grass and types of grass being mowed.

- The average lawn should be cut approx. 1-1/2" to 2 inches during the cool season and over 2 inches during hot months. For healthier and better looking lawns, mow often and after moderate growth.

BEFORE STARTING ENGINE

OIL & GAS MIXING

- Use a clean, high quality 2 cycle oil. DO NOT use multi-viscosity oils. Such oils may not provide adequate lubrication and additives in the oil may cause fouling of the spark plug resulting in difficult or non-starting of the engine. DISREGARD THE MIXING INSTRUCTIONS ON THE OIL CONTAINER. Follow the instructions below.
- Use fresh, clean, unleaded automotive gasoline. (Leaded gasoline and oil mix can be used). DO NOT USE PREMIUM OR HIGH OCTANE GASOLINE.

WARNING: Experience indicates that alcohol blended fuels (called gasohol or using ethanol or methanol) can attract moisture which leads to separation and formation of acids during storage. Acidic gas can damage the fuel system of an engine while in storage. To avoid engine problems, the fuel system should be emptied before storage for 30 days or longer. Drain the gas tank, start the engine and let it run until the fuel lines and carburetor are empty. Use fresh fuel next season. See Storage Instructions for additional information. Never use engine or carburetor cleaner products in the fuel tank or permanent damage may occur.

- **TO MIX OIL & GASOLINE** - To assure thorough mixing of oil and gasoline, fill an approved, clean container with recommended gasoline to one quarter full. Add recommended oil per 24:1 mix ratio. (One gallon of gasoline requires 5 ounces of oil).
- Screw cap tightly on container and shake vigorously. Then unscrew cap and fill container with gasoline until full. Once oil and gasoline are mixed they will not separate.
- DO NOT MIX OIL AND GASOLINE DIRECTLY IN THE ENGINE FUEL TANK. This will allow oil to enter the carburetor which will cause engine to be inoperative.

TO START ENGINE

- Connect spark plug wire to spark plug.
- PRIME ENGINE (See Fig. 5 on page 7) -
 - A. To start a new engine, or one that has run out of fuel, push primer 12 to 15 times to fill fuel lines and carburetor. Use firm full pushes.
 - B. To start a cold engine which has been run previously, but not emptied of fuel, push primer 1 time using a full push.

OPERATION

TO START ENGINE (Cont.)

- C. To start a warm engine, priming is not usually necessary. (If engine does not start after three pulls of the starter, push primer 1 time using a full push).
- Hold operator presence control bar down to the handle and pull starter handle quickly. Do not allow starter rope to snap back.
 - To "STOP" engine, release operator presence control bar.

NOTE: In cooler weather it may be necessary to use 2 pushes and repeat priming steps between pulls. In warmer weather over priming may cause flooding and engine will not start. If you do flood engine wait a few minutes before attempting to start and DO NOT repeat priming steps.

MOWING TIPS

- Under certain conditions, such as very tall grass, it may be necessary to raise the height of cut to reduce pushing effort and to keep from overloading the engine and leaving clumps of grass clippings.
- For extremely heavy cutting, reduce the width of cut.
- Pores in cloth grass catchers can become filled with dirt and dust with use and catchers will collect less grass. To prevent this, regularly hose catcher off with water and let dry before using.

MAINTENANCE

GENERAL RECOMMENDATION

- Once a year you should replace the spark plug, air filter, and check blade for wear. A new spark plug and air filter assures proper air-fuel mixture and helps your engine run better and last longer.
- Follow the Service Recommendation Schedule on page 12.

MOWER

BLADE CARE

Your mower will work better with a sharp blade.



CAUTION: DISCONNECT SPARK PLUG WIRE FROM SPARK PLUG AND PLACE WIRE WHERE IT CANNOT COME IN CONTACT WITH THE SPARK PLUG.

TO REMOVE BLADE (SEE FIG. 7):

- Turn mower on its side. Make sure air filter and carburetor are up.
- Use a block of wood between blade and mower housing to prevent blade from turning when bolt is removed. Protect your hands with gloves and/or wrap blade with heavy cloth.
- Remove blade bolt by turning counterclockwise. Use a 9/16" box or open-end wrench.

NOTE: Check the blade bolt lock washer at each removal for damage and replace if necessary. The lock washer should be replaced after every three (3) blade removals to insure proper tightness.

TO REPLACE BLADE (SEE FIG. 7):

- Make sure key is in slot in crankshaft.
- Put blade adaptor on engine crankshaft.
- Fit blade in adaptor. Be sure trailing edge of blade is up towards engine.
- Assemble retainer plate, lock washer (undamaged) and blade bolt.
- Use block of wood to hold blade and tighten bolt clockwise. The recommended torque is 35 - 40 ft. lbs.

NOTE: The bolt used to secure the blade to engine is specially heat treated. Do not substitute (See Repair Parts).



CAUTION: A LOOSE BLADE CAN BE DANGEROUS AND MAY MAKE THE ENGINE HARD TO START.

Use only an original manufacturer's replacement blade to get the best cutting results.

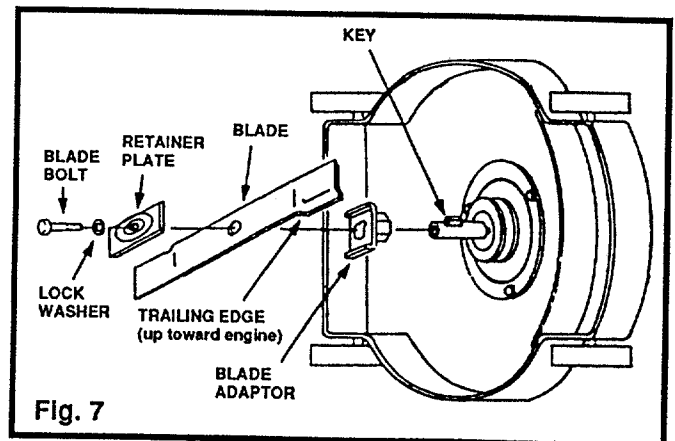

MAINTENANCE

NOTE: We do not recommend sharpening the blade - but if you do, be sure blade is balanced.

TO SHARPEN BLADE:

- The blade can be sharpened with a file or on a grinding wheel. Do not attempt to sharpen while on the mower.
- Care should be taken to keep the blade balanced. An unbalanced blade will cause excessive vibration when running and eventual damage to mower and engine.
- To check blade balance, drive a nail into a beam or wall. Leave about one inch of the straight nail exposed. Place center hole of blade over the head of the nail. If blade is balanced, it should remain in a horizontal position. If either end of the blade moves downward, blade is not balanced. Sharpen the heavy end until the blade is balanced.

ENGINE

SPARK PLUG

Change your spark plug each year to make your engine start easier and run better. Set spark plug gap at .025 inch.

AIR FILTER

Your engine will not run properly and may be damaged by using a dirty air filter.

Replace the air filter every year, more often if you mow in very dusty, dirty conditions. Do not wash air filter. Filters are available at your nearest Tecumseh Dealer.

CLEANING



CAUTION: DISCONNECT SPARK PLUG WIRE FROM SPARK PLUG AND PLACE WIRE WHERE IT CANNOT COME IN CONTACT WITH THE SPARK PLUG.

- Turn mower on its side with carburetor up.
- Clean the underside of your mower by scraping to remove build-up of grass and trash.

NOTE: We recommend that you clean the underside of your mower after each use.

- Clean your mower and engine often to keep build-up of trash from accumulating around engine. A clogged engine runs hotter and shortens engine life.

NOTE: We DO NOT recommend using a garden hose to clean mower unless the electrical system, muffler, air filter and carburetor are covered to keep water out. Water in engine can result in shortening engine life.

SERVICE AND ADJUSTMENTS

TO ADJUST CUTTING HEIGHT

See "ADJUST CUTTING HEIGHT" in operation section of manual.

CARBURETOR

Your carburetor has a non-adjustable fixed main jet for mixture control. If your engine does not operate properly due to suspected carburetor problems, take your mower to a authorized Service Center for repair and adjustment.

ENGINE SPEED

Your engine speed has been factory set. Do not attempt to increase engine speed or it may result in personal injury. If you believe that the engine is running too fast or too slow, take your mower to an authorized Service Center for repair and adjustment.

REAR TRAIL SHIELD

The rear trail shield, attached between the rear wheels of your mower, is provided to minimize the possibility that objects will be thrown out the rear of the mower into the operator mowing position. If the shield becomes damaged, it should be replaced.

STORAGE

Your mower and engine should be prepared for off-season storage as follows:

MOWER

- Clean underside of mower housing (See "CLEANING" in maintenance section of manual).
- Inspect and replace/sharpen blade, if required (See "BLADE CARE" in maintenance section of manual).
- Lubricate as shown in Service Recommendation chart on page 12 of manual.

HANDLE (See Fig. 8)

You can fold your mower handle for storage as shown.

- Loosen the two (2) hand knobs on sides of the handle and let the upper handle fold down to the rear.
- Loosen knob securing lower handle and pivot entire handle assembly forward and allow it to rest on mower.

CAUTION: When folding handle for storage or transportation, be careful not to bend or kink the engine control cable.

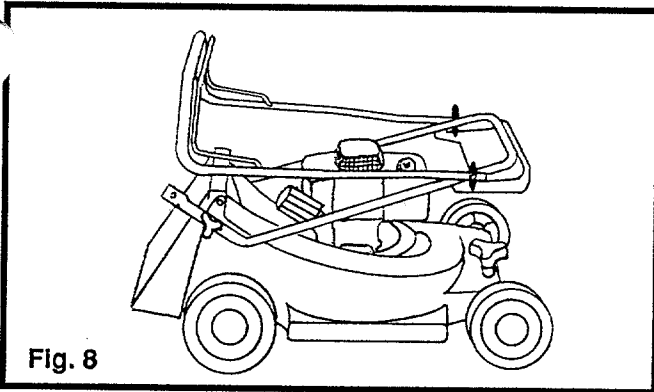

Fig. 8



CAUTION: NEVER STORE THE LAWN MOWER WITH GASOLINE IN THE TANK INSIDE A BUILDING WHERE FUMES MAY REACH AN OPEN FLAME OR SPARK. ALLOW THE ENGINE TO COOL BEFORE STORING IN ANY ENCLOSURE.

ENGINE

Drain fuel and run engine until fuel system is empty.

IMPORTANT: IT IS IMPORTANT TO PREVENT GUM DEPOSITS FROM FORMING IN ESSENTIAL FUEL SYSTEM PARTS SUCH AS CARBURETOR, FUEL FILTER, FUEL HOSE, OR TANK DURING STORAGE. ALSO, EXPERIENCE INDICATES THAT ALCOHOL BLENDED FUELS (CALLED GASOHOL OR USING ETHANOL OR METHANOL) CAN ATTRACT MOISTURE WHICH LEADS TO SEPARATION AND FORMATION OF ACIDS DURING STORAGE. ACIDIC GAS CAN DAMAGE THE FUEL SYSTEM OF AN ENGINE WHILE IN STORAGE.

OTHER

- Do not store gasoline from one season to another.
- Replace your gasoline can if your can starts to rust. Rust and/or dirt in your gasoline can cause problems.
- Do not store your mower under any plastic cover. Plastic cannot breathe which allows condensation to form and cause the metal components of your mower to rust.

SERVICE RECOMMENDATIONS

SERVICE RECORD <small>Fill in Dates as you complete regular service</small>	SCHEDULE		SERVICE DATES					
	Every 25 Hours	Every Use						
Blade Replaced	✓							
Blade Lock Washer Checked/ Replaced (See "BLADE CARE")								
Air Cleaner Replaced	✓							
Spark Plug Replaced	✓							
Lubricate Mower	✓							
Cleaning		✓						
Grass Catcher	✓							
Muffler	✓							

✓ - CHECK

LUBRICATION

ENGINE

Your mower has a 2-cycle engine. The engine is lubricated by the oil you mix with the gasoline.

WHEELS

DO NOT oil or grease the wheel bearings. Viscous lubricants will attract dust and dirt that will shorten the life of the self-lubricating wheel bearings. If you feel the wheels must be lubricated, use only a dry, silicone type lubricant sparingly.

TROUBLE SHOOTING POINTS

PROBLEM	CAUSE	CORRECTION
Does not start	<ol style="list-style-type: none"> 1. Dirty Air Filter. 2. Out of fuel. 3. Stale fuel. 4. Spark plug wire is disconnected. 5. Bad spark plug. 6. Water in fuel. 7. Improper mixture of gasoline and oil. 8. Loose blade. 9. Operator Presence Control Bar in released position. 10. Operator Presence Control Bar defective. 	<ol style="list-style-type: none"> 1. Replace Air Filter 2. Fill fuel tank. 3. Drain fuel tank and refill with mixture of fresh gasoline and oil. 4. Connect wire to spark plug. 5. Replace spark plug. 6. Drain fuel tank and refill with mixture of fresh gasoline and oil. 7. Drain fuel tank and refill with proper mixture of gasoline and oil. 8. Tighten blade bolt (Check lock washer). 9. Depress Operator Presence Control Bar. 10. Replace Control Bar.
Loss of Power	<ol style="list-style-type: none"> 1. Cutting too much grass. 2. Dirty Air Filter. 3. Build-up of grass, leaves and trash under mower. 	<ol style="list-style-type: none"> 1. Set in "Higher Cut" position. 2. Replace Air Filter. 3. Disconnect spark plug wire and clean underside of mower housing.
Poor cut - Uneven	<ol style="list-style-type: none"> 1. Worn, bent or loose blade. 2. Build-up of grass, leaves and trash under mower. 	<ol style="list-style-type: none"> 1. Replace blade. Tighten blade bolt. 2. Disconnect spark plug wire and clean underside of mower housing.
Too much Vibration	<ol style="list-style-type: none"> 1. Worn, bent or loose blade. 2. Bent engine crankshaft. 	<ol style="list-style-type: none"> 1. Replace blade. Tighten blade bolt. 2. Contact authorized Service Department.
Starter Rope Hard to Pull	<ol style="list-style-type: none"> 1. Engine brake is on when Operator Presence Control Bar is released. 2. Bent engine crankshaft. 3. Blade dragging in grass. 	<ol style="list-style-type: none"> 1. Depress Operator Presence Control Bar to upper handle before pulling on starter rope. 2. Contact authorized Service Department. 3. Get over low grass and/or hard surface to start engine.
Hard to Push	<ol style="list-style-type: none"> 1. High grass or cutting height too low. 2. Rear of mower housing/blade dragging in heavy grass. 	<ol style="list-style-type: none"> 1. Raise cutting height. 2. Raise cutting height.

Model 127R

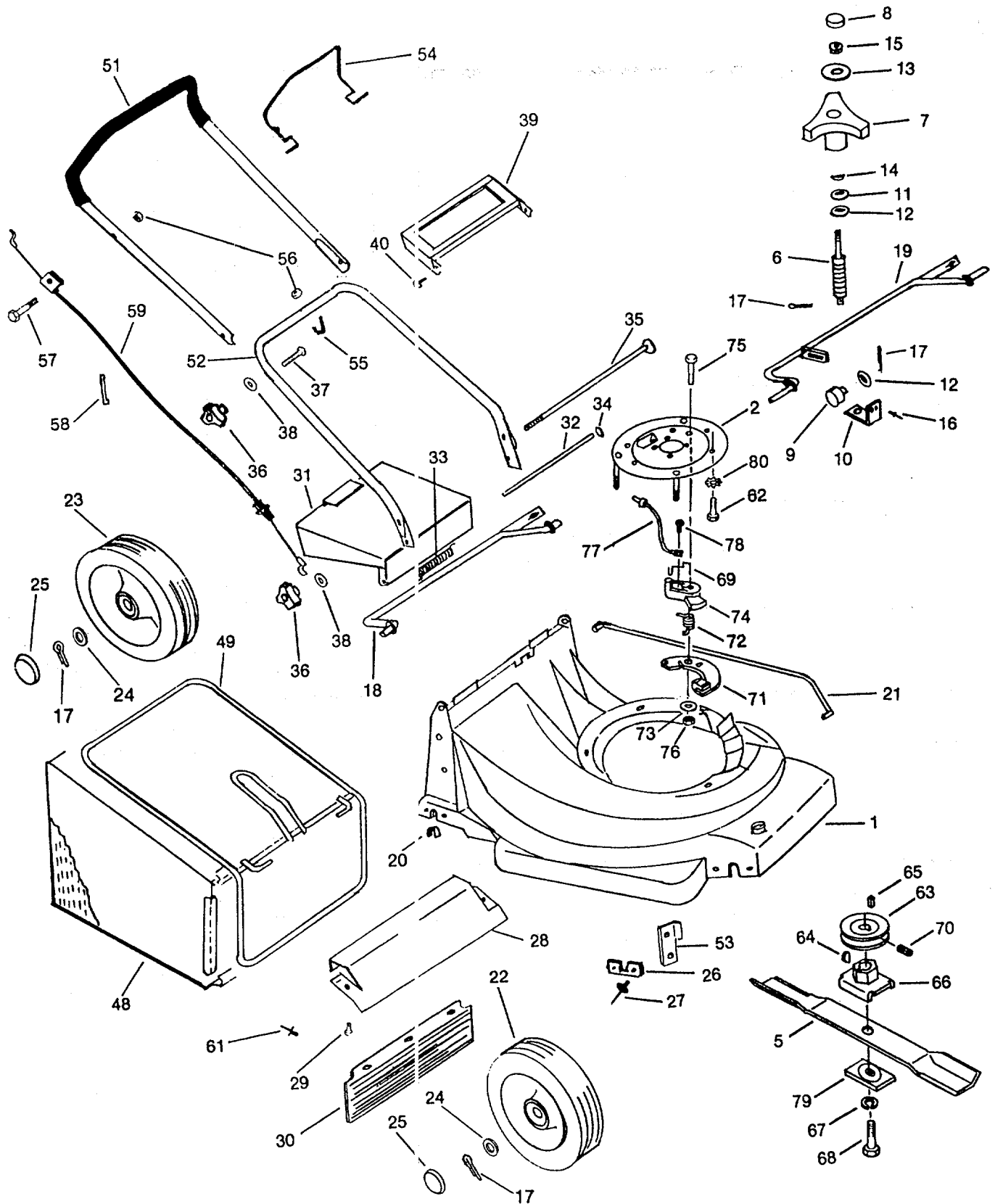

Model 127R

PARTS LIST FOR MODEL 127R ROTARY MOWER

REF. NO.	PART NO.	CODE	DESCRIPTION	REF. NO.	PART NO.	CODE	DESCRIPTION
1	706-13761-01-60	N	Deck—16" Molded	38	706-10057-01	N	Saddle Washer
2	706-13859-02-90	N	Plate Assembly—Engine Mtg.	39	706-10320-01-90	N	Trimplate
5	706-13813-00-08	N	Blade—16"	40	706-10125-12	N	Screw #10 x 3/4"
6	706-13768	N	Adjuster Screw	48	706-13826-01	N	Grass Bag
7	706-13764-00-90	N	Knob—Height Adjust	49	706-13769-02	N	Frame Assembly—Grass Bag
8	706-13854	N	Plug—Height Adjust Knob	51	706-13820-01	N	Upper Handle w/Foam Grip
9	706-13767	N	Trunnion—Height Adjust	52	706-13830-02-91	N	Lower Handle
10	706-13860	N	Bracket—Screw Brace	53	706-13971-00-90	N	Brace—Front Axle
11	706-13876	N	Washer (Special)	54	706-13840-00-90	N	Lever—Engine Control
12	706-13877	N	Washer (Special)	55	706-10616	N	Rope Guide (J-Bolt)
13	706-13878	N	Washer (Special)	56	706-11909	N	L-Nut 1/4-20 Thd.
15	706-13845	N	Nut—Metric (Special)	57	710-0106	N	Hex Bolt 1/4-20 x 1-1/4" *
16	706-10676	N	Blind Rivet 3/16"	58	706-10065	N	Plastic Tie
17	714-0507	N	Cotter Pin 3/32 x 3/4"	59	706-13816	N	Cable—Engine Control
18	706-13810-05-90	N	Rear Axle Assembly	61	706-13218	N	Blind Rivet
19	706-13810-06-90	N	Front Axle Assembly	62	710-0258	N	Engine Mtg. Bolt
20	706-13875-01	N	Bushing—Axle	63	706-13856	N	Pulley—Brake
21	706-13842-00-90	N	Link Rod	64	706-13988	N	Square Key
22	734-1658	N	Wheel—6"	65	714-0138	N	Woodruff Key #6
23	734-1659	N	Wheel—7"	66	706-13807-01-05	N	Adapter—Blade Mtg.
24	736-0185	N	Fl-Wash. 3/8"	67	736-0217	N	L-Wash. 3/8" I.D.
25	706-10740	N	Hub Cap	68	706-10006-16	N	Blade Bolt (Special)
26	706-13858	N	Retainer—Front Axle	69	706-13863-01	N	Spring—Contact
27	706-13821	N	Blind Rivet 5/32"	70	706-16118	N	Set Scr. 5/16-18 x 3/8"
28	706-13766-01-90	N	Support—Deck & Trail Shield	71	706-13806-02	N	Arm Assembly—Brake
29	706-13822	N	Screw—Metric (Special)	72	706-13865-02	N	Spring—Brake Arm
30	706-13872	N	Trail Shield	73	706-15829	N	Fl-Wash. 3/8"
31	706-14388-00-90	N	Rear Door Assembly	74	706-13815-01	N	Housing—Spring
32	706-13849	N	Hinge Pin	75	710-0347	N	Hex Bolt 3/8-16 x 1-3/4"
33	706-14389	N	Spring—Rear Door	76	712-0430	N	L-Nut 3/8-16 Thd.
34	706-13843	N	Retainer—Push Nut (Special)	77	706-13915	N	Wire Assembly—Eng. Control
35	706-13848-01	N	Pin—Handle	78	706-11785-06	N	Screw #6-20 x 3/8"
36	706-10488	N	Knob—Handle	79	706-10110-00-05	N	Retainer Plate
37	706-10072-32	N	Saddle Bolt	80	736-0498	N	Int. L-Wash. 5/16" I.D.

*For faster service obtain standard nuts, bolts and washers locally. If these items cannot be obtained locally, order by part number and size as shown on parts list.



Specifications subject to change without notice or obligation.

NOTE: The engine is not under warranty by the mower manufacturer. . . If repairs or service is needed on the engine, please contact your nearest authorized engine service outlet. Check the "Yellow Pages" of your telephone book under "Engines—Gasoline."



PARTS INFORMATION

POWER EQUIPMENT PARTS AND SERVICE

Parts and service are available through the authorized service firms listed below. All orders should specify the model number of your unit, part numbers, description of parts and the quantity of each part required.

NOTE: If any parts are found to be missing or defective upon assembly of this unit, write to advise the factory so that immediate replacement can be made.

ARKANSAS	NORTH LITTLE ROCK
Sutton's Lawn Mower Shop	5301 Roundtop Drive Box 368, Rt. 4 72117
CALIFORNIA	PORTERVILLE
Billious	75 North D Street 93257
COLORADO	DENVER
Spitzer Industrial Products Co.	6601 N. Washington St. 80229
FLORIDA	JACKSONVILLE
Radco Distributors	4909 Victor St. Box 5459 32207
	HIALEAH
Small Eng. Dist.	7995 W. 26th Court 33016
ILLINOIS	LYONS
Keen Edge Co.	8615 Ogden Ave. 60534
INDIANA	ELKHART
Parts & Sales Inc.	2101 Industrial Pkwy. Box 277 46516
IOWA	DUBUQUE
Power Lawn & Garden Equip.	2551 J.F. Kennedy 52001
MARYLAND	BELTSVILLE
Center Supply Co.	6802 Industrial Dr. #208 20705
MASSACHUSETTS	SPRINGFIELD
Morton B. Collins Co.	300 Birnie Ave. 01107
MICHIGAN	MOUNT CLEMENS
Power Equipment Dist.	340 Hubbard 48043
MINNESOTA	PLYMOUTH
Hance Distributing Inc.	12795 16th Ave. North 55441
MISSOURI	EARTH CITY
Oscar Wilson Engine & Parts	4159 Shoreline Dr. 63045
	KANSAS CITY
Automotive Equip. Service	3117 Holmes St. 64109
NEW YORK	CARTHAGE
Gamble Dist., Inc.	West End Ave. Box 389 13619

BRIGGS AND STRATTON, TECUMSEH AND PEERLESS PARTS AND SERVICE

Briggs & Stratton, Tecumseh and Peerless parts and service should be handled by your nearest authorized engine service firm. Check the yellow pages of your telephone directory under the listing **Engines—Gasoline**, Briggs & Stratton or Tecumseh Lauson.

NORTH CAROLINA	BROWNS SUMMIT
Dixie Sales Company	5920 Summit Ave. 27214
OHIO	CARROLL
Stebe's Mid-State Mower Supply	Box 366, 71 High St. 43112
	CLEVELAND
Bleckrie, Inc.	7900 Lorain Ave. 44102
	WADSWORTH
National Central	687 Seville Rd. 44281
	YOUNGSTOWN
Burton Supply Co.	1301 Logan Ave. Box 929 44501
PENNSYLVANIA	HARRISBURG
EECO Inc.	4021 N. 6th St. 17110
	PITTSBURGH
Bluemont Co.	11101 Frankstown Rd. 15235
	PUNXSUTAWNEY
Frank Roberts & Sons	R.D. 2 15767
	SCRANTON
Scranton Auto Ignition Co.	1133-35 Wyoming Ave. 18509
TENNESSEE	KNOXVILLE
Ace Distributors	2103 Magnolia 37917
	NASHVILLE
Chilton Air Cooled Engine	319 4th Ave. S. 37210
TEXAS	DALLAS
Marr Brothers, Inc.	423 E. Jefferson 7520
UTAH	SALT LAKE CITY
Powered Products	1661 N. Beck St. 84116
VIRGINIA	ASHLAND
RBI Corp.	101 Cedar Ridge Dr. 23005
WASHINGTON	SEATTLE
Equip. Northwest	1410 14th Ave. 98122
WISCONSIN	MILWAUKEE
Wisconsin Magneto Inc.	4727 N. Teutonia St. 53209
PUERTO RICO	RAMEY
Island Distribution Center	102 N. St. 00604

WARRANTY PARTS AND SERVICE POLICY

(0689)

The purpose of warranty is to protect the customer from defects in workmanship and materials, defects which are NOT detected at the time of manufacture. It does not provide for the unlimited and unrestricted replacement of parts. Use and maintenance are the responsibility of the customer. The manufacturer cannot assume responsibility or conditions over which it has no control. Simply put, if it's the manufacturer's fault, it's the manufacturer's responsibility; if it's the customer's fault, it's the customer's responsibility.

CLAIMS AGAINST THE MANUFACTURER'S WARRANTY INCLUDES:

1. Replacement of Missing Parts on new equipment.
2. Replacement of Defective Parts within the warranty period.
3. Repair of Defects within the warranty period.

All claims MUST be substantiated with the following information:

1. Model Number, Serial Number and/or Date Code of unit involved.
2. Date unit was purchased.
3. Date of Failure.
4. Nature of Failure.