



3 YEAR LIMITED WARRANTY
MOTOR BASE PARTS ONLY
1 YEAR PARTS AND LABOR
ON TOTAL UNIT

THE ULTIMATE QUIET BEVERAGE BLENDER

LO MÁXIMO DE LICUADORAS SILENCIOSAS PARA BEBIDAS

With 34 blender programs, the Blending Station Advance has been programmed for perfection – each program combines the right speed and timing to eliminate guesswork and to create quality drinks! A streamlined cover saves counter space while minimizing sound for an improved customer experience.

Con 34 programas, se programó la Blending Station Advance para la perfección.

¡Cada programa combina la velocidad y el tiempo exacta para eliminar el trabajo a ciegas y para crear bebidas de alta calidad! Una cubierta aerodinámica le ahorra espacio en el mostrador mientras minimiza el sonido y mejora la experiencia del cliente.

BLENDING STATION® ADVANCE

BLENDING STATION® ADVANCE: THE ULTIMATE, QUIET BEVERAGE BLENDER

BLENDING STATION ADVANCE: LO MÁXIMO DE LICUADORAS SILENCIOSAS PARA BEBIDAS

POWERFUL ≈3 PEAK HP MOTOR

PODEROSO MOTOR
DE ≈3 HP (PICO)



- Unmatched performance for coffee, smoothie, and ice cream shops
- Reliably and quickly blends dense ingredients without overheating
- Rendimiento incomparable para las cafeteras, los restaurantes y las heladerías
- Licua ingredientes espesos con rapidez sin problemas de sobrecalentamiento

VARIABLE SPEED CONTROL

CONTROL DE VELOCIDAD
VARIABLE



- 93 speeds for the ultimate in blending flexibility
- Easy control and versatility at the touch of a button
- 93 velocidades para máxima flexibilidad
- Control y versatilidad al simple toque de un botón.

34 OPTIMIZED PROGRAMS WITH AUTOMATIC SHUT-OFF

34 PROGRAMAS OPTIMIZADOS
CON APAGADO AUTOMÁTICO



- Programs automated for the best blending quality and consistency
- Automatic shut-off gives operators the freedom to serve other customers for improved speed of service
- Programas automatizados para la mejor calidad y consistencia de licuar
- El apagado automático le permite servirles a varios clientes y así mejorar la calidad del servicio

COMPACT SOUND COVER

CUBIERTA COMPACTA
Y ACÚSTICA



- Unique cover hinge design saves counter space
- Made of a durable material to minimize noise and improve customer experience
- Bisagra con diseño especial en la cubierta le ahorra espacio en el mostrador
- Fabricada de material duradero para minimizar el sonido y mejorar la experiencia del cliente

SPECIFICATIONS FOR #36006

Motor:..... ≈ 3 peak HP
 Electrical:..... 120V, 50/60 Hz, 15 Amps
 Pack: Includes 1 Blending Station Advance with 48 oz. / 1.4 Ltr. high-impact, clear / stackable XP Container and Blade
 Net Weight:..... 19.5 lbs. / 8.9 kg
 Product Dimensions:.. 19.375 in. / 49.21 cm HIGH
 9.25 in. / 23.49 cm WIDE
 10 in. / 25.59 cm DEEP

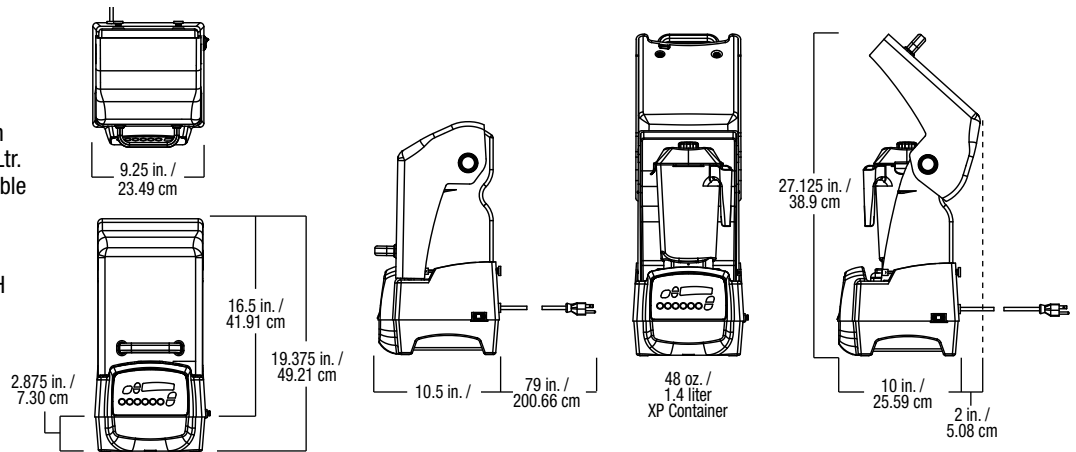

WARRANTY: In the United States and Canada, the Blending Station Advance is backed by a three-year limited warranty on motor base parts and a one-year limited warranty on parts and labor on the full unit. See the Owner's Manual for details. For more information regarding this warranty, please contact Customer Service at 440-235-0214. If purchased outside the U.S. or Canada, please contact your authorized Vita-Mix Distributor.



For more information, contact your local foodservice distributor below.



VITA-MIX HAS
THE PERFECT
PRODUCT FOR
YOUR BUSINESS.

www.vitamix.com/blendingstation

USA, CANADA AND LATIN AMERICA:
 Tel: 440-235-0214
 800-4DRINK4
 Fax: 440-235-9670
 E-mail: foodservice@vitamix.com

ALL OTHER COUNTRIES:
 Tel: +1.440.782.2450
 Fax: +1.440.782.2220
 E-mail: international@vitamix.com