



**Wireless Thermo Clock
Model : RMR602A**

User Manual



21

CONTENTS

Contents	1
Introduction	2
About Oregon Scientific	2
Product Overview	3
Front View	3
Back View	4
Remote Sensor	5
Getting Started	6
Batteries	6
Change Settings	6
Table Stand or Wall Mount	6
Remote Sensor	6
Setup Sensor	7
Data Transmission	8
Search for Sensor	8
Clock	8
Turn Atomic Clock ON/OFF	9
Set Clock	9
Switch Clock Display	9
Alarm	9
View Alarm Settings	9
Set Alarm	9
Activate Alarm	9
Stop Alarm	9
Temperature	10
Select Temperature Unit	10
Minimum / Maximum Records	10
Reset System	10
Safety and Care	10
Warnings	11
Troubleshooting	11
Specifications	12
Main Unit Dimensions	12
Remote Sensor Dimensions	12
Temperature	12
Remote Sensor	12
Clock	12
Power	12
FCC Statement	13

INTRODUCTION

Thank you for selecting the Oregon Scientific™ Wireless Thermo Clock (RMR602A). This device bundles precise time keeping, alarm, and temperature monitoring features into a single tool you can use from the convenience of your home.

In this box, you will find:

- Main unit
- Remote sensor

Keep this manual handy as you use your new product. It contains practical step-by-step instructions, as well as technical specifications and warnings you should know.

ABOUT OREGON SCIENTIFIC

Visit our website (www.oregonscientific.com) to learn more about other Oregon Scientific products such as digital cameras, hand-held organizers, health and fitness gear, and projection clocks. The website also includes contact information for our customer service department, in case you need to reach us.

PRODUCT OVERVIEW

FRONT VIEW

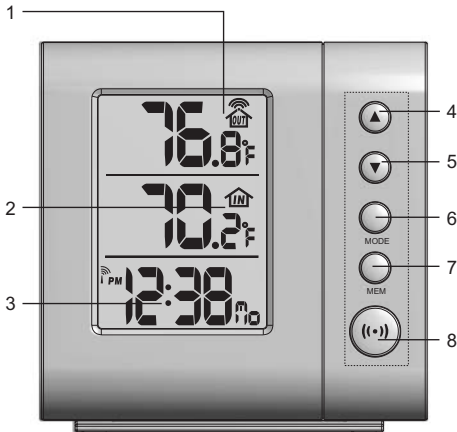

1. **Outdoor Temperature Area:** Readings, sensor battery and reception status
2. **Indoor Temperature Area:** Readings and main unit battery status.
3. **Clock / Alarm Area:** Time, day of week, month, date, alarm
4. **▲:** Press to increase setting or enable Atomic Clock signal reception / alarm
5. **▼:** Press to decrease setting or disable Atomic Clock signal reception / alarm
6. **MODE:** Press to change display / settings
7. **MEM:** Press to view current or saved max / min temperature readings
8. **((.)):** Press to view alarm settings



EN

BACK VIEW

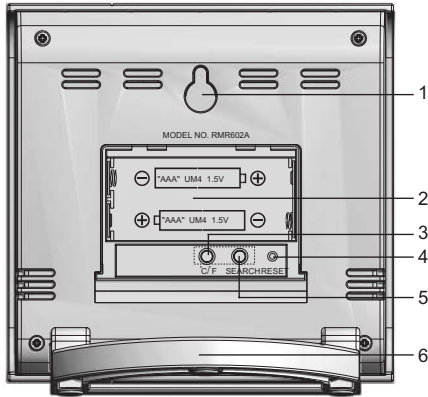

1. Wall mount
2. Battery compartment
3. °C / °F switch
4. **RESET** hole
5. **SEARCH** button
6. Table stand



Σ

REMOTE SENSOR

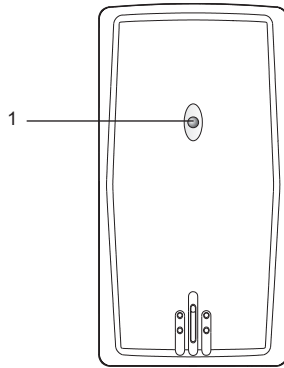

1. LED Status indicator

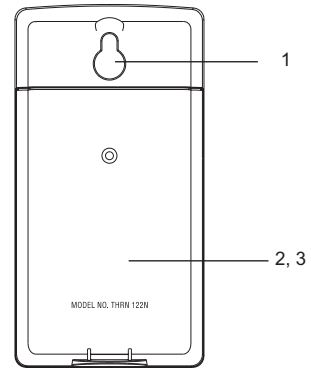

1. Wall mount hole
2. Battery compartment
3. Battery compartment cover

GETTING STARTED

BATTERIES

Batteries are not supplied with this product. You will need to purchase 2 x UM-4 (AAA) 1.5V alkaline batteries for the main unit, and 2 x UM-3 (AA) 1.5V alkaline batteries for the remote sensor.

Insert batteries before first use, matching the polarity as shown in the battery compartment. For best results, install batteries in the remote sensor before the main unit. Press **RESET** after each battery change.

NOTE Do not use rechargeable batteries.

 shows when batteries are low.

UNIT	 LOCATION
Main	Indoor Temperature Area
Remote	Outdoor Temperature Area.

CHANGE SETTINGS

1. Press and hold **MODE** for 2 seconds to enter setting mode.
2. Press **UP** or **DOWN** to change settings.
3. Press **MODE** to confirm.

TABLE STAND OR WALL MOUNT

Use the stand on the back of the product, or mount it on a wall with a nail.



REMOTE SENSOR

This product is shipped with a remote sensor that collects temperature readings. Only one sensor can be used with this product.



7

SETUP SENSOR

1. Open the remote sensor battery compartment with a small Phillips screwdriver.
2. Insert the batteries, matching the polarity as shown in the battery compartment.
3. Place the sensor near the main unit. Press **RESET**, then **SEARCH**, on the main unit to initiate signal sending between the sensor and the main unit. The reception icon on the main unit will blink for approximately 3 minutes while it is searching for the sensor. (Refer to the Sensor Data Transmission section for more information.)
4. Close the remote sensor battery compartment.
5. Secure the sensor in the desired location using the wall mount or table stand.

For best results:

- Insert the batteries before you mount the sensor.
- Place the sensor out of direct sunlight and moisture.
- Do not place the sensor more than 30 meters (98 feet) from the main (indoor) unit.
- Position the sensor so that it faces the main (indoor) unit, minimizing obstructions such as doors, walls, and furniture.
- Place the sensor in a location with a clear view to the sky, away from metallic or electronic objects.
- Position the sensor close to the main unit during cold winter months as below-freezing temperatures may affect battery performance and signal transmission.

You may need to experiment with various locations to get the best results.



DATA TRANSMISSION

Data is sent from the sensor(s) every 78 seconds. The reception icon shown in the Outdoor Temperature Area shows the status.

ICON	DESCRIPTION
	Main unit is searching for sensor.
	Sensor signal is steady.
--- shows	The sensor cannot be found. Search for the sensor or check batteries.

SEARCH FOR SENSOR

To search for the sensor, press **SEARCH**. The **SEARCH** button is located in the main unit battery compartment.

NOTE If the sensor is still not found, check the batteries, obstructions, and remote unit location.

NOTE Signals from household devices such as doorbells, electronic garage doors, and home security systems may cause temporary reception failure. This is normal and does not affect general product performance. The reception will resume once the interference ends.

CLOCK

This product has two displays: Clock with day of week in German, English, French, Italian, or Spanish, and Calendar display with month and date. The time is automatically updated by the US Atomic Clock in Boulder, Colorado unless you disable this feature. Signals are collected by the main unit when it is within 1500 km (932 miles) of a signal.

Initial reception takes 2 - 10 minutes, and is initiated when you first setup the unit, and whenever you press **RESET**. Once complete, the reception icon will stop blinking. The icon is shown in the Clock Area.

Strong signal	Weak signal	No signal

To force a manual search for Atomic Clock signals, press and hold **UP** for 2 seconds. If no signal is found, check the batteries.

NOTE If the Atomic Clock signal is received and the hour is incorrect, use the "hour offset" feature to adjust it to the right value. Please see "SET CLOCK" on pg. 9 for instructions.



25

TURN ATOMIC CLOCK ON/OFF

Perform this step if you cannot receive Atomic Clock signals. Press and hold **DOWN** for 2 seconds. Then, manually set the clock following the "Set Clock" instructions (below).



The signal icon indicates that the Atomic Clock feature is ON. No icon means that it is OFF.

SET CLOCK

You only need to do this if you have disabled the Atomic Clock feature (for example, if you are too far from or cannot receive a signal).

1. Press and hold **MODE** for 2 seconds. The Clock Area will blink.
2. Select the hour offset (-9 to +9), hour display format (12 or 24 hour), hour, minute, year, month, day, and language. Press **UP** or **DOWN** to change the setting. Press **MODE** to confirm.

NOTE The language options are (D) German, (E) English, (F) French, (I) Italian, and (S) Spanish.

SWITCH CLOCK DISPLAY

Press **MODE** to toggle between Calendar and Clock display with Hour Offset, Seconds, or Weekday.

ALARM

This product has 2 alarms: a Single Alarm and a Weekday Alarm. The Single Alarm can be set to go off at a specific time for a one-time event (for example, if you are napping on Saturday). The Weekday Alarm will sound at the same time Monday - Friday (but not on weekends).

VIEW ALARM SETTINGS

Press **((.))** to display the Alarm settings you wish to view: **☞** Weekday or **☞** Single.

SET ALARM

1. Press **((.))** to display the type of Alarm you wish to set: **☞** Weekday or **☞** Single.
2. Press and hold **((.))** again for 2 seconds. The Alarm settings will blink.
3. Select the hour and minute. Press **UP** or **DOWN** to change settings. Press **((.))** to confirm.

ACTIVATE ALARM

Press **▲** or **▼** to activate or deactivate the Alarm. --- indicates that the alarm is deactivated.

STOP ALARM

To stop the alarm from ringing, press **((.))**.



MEM

TEMPERATURE

This product can display current, maximum, and minimum temperature readings collected by the main unit (indoor) and remote sensor (outdoor).

Outdoor temperature data collected by the remote sensor is updated every 78 seconds.

SELECT TEMPERATURE UNIT

Press the °C / °F button to switch between temperature units. The button is located in the battery compartment.

MINIMUM / MAXIMUM RECORDS



Press **MEM** to toggle between current, maximum (MAX) and minimum (MIN) records.

To clear the records, press and hold **MEM** for 2 seconds. The current temperature readings will be shown as the minimum and maximum records.

RESET SYSTEM

The **RESET** button is located in the battery compartments for the main unit. Press **RESET** when you change the batteries and whenever performance is not behaving as expected (for example, unable to establish radio frequency link with remote sensor or radio-controlled clock).

NOTE When you press **RESET**, all settings will return to default value, and you will lose all stored information.

SAFETY AND CARE



Clean the product with a slightly damp cloth and alcohol - free mild detergent. Avoid dropping the product or placing it in a high-traffic location.



WARNINGS

This product is designed to give you years of service if handled properly. Observe the following guidelines:

- Never immerse the product in water. This can cause electrical shock and damage the product.
- Do not subject the main unit to extreme force, shock, or fluctuations in temperature or humidity.
- Do not tamper with the internal components.
- Do not mix new and old batteries or batteries of different types.
- Do not use rechargeable batteries with this product.
- Remove the batteries if storing this product for a long period of time.
- Do not scratch the LCD display.

Do not make any changes or modifications to this product. Unauthorized changes may void your right to use the product. The technical specification of this product and contents of this user guide are subject to change without notice. Images not drawn to scale.

TROUBLESHOOTING

Check here before contacting our customer service department.

Problem	Symptom	Remedy
Calendar	Strange date / month	Change language (→ 9)
Clock	Cannot adjust clock	Disable Atomic Clock (→ 9)
	Cannot auto-synch	<ol style="list-style-type: none"> 1. Adjust batteries. (→ 6) 2. Press RESET (→ 10) 3. Manually activate Atomic Clock feature (→ 9)
Temp	Shows "LLL" or "HHH"	Temperature is out-of-range
Remote sensor	Cannot locate remote sensor	Check batteries (→ 6)
		Check location (→ 7)
	Data does not match main unit	Initiate a manual sensor search (→ 8)

SPECIFICATIONS

MAIN UNIT DIMENSIONS

L x W x H	100 x 47 x 99 mm (3.94 x 1.85 x 3.90 inches)
Weight	4.80 ounces with battery

REMOTE SENSOR DIMENSIONS

L x W x H	96 x 50 x 28 mm (3.8 x 2.0 x 1.1 inches)
Weight	1.62 ounce without battery

TEMPERATURE

Unit	°C or °F
Indoor Range	-5 °C to 50 °C (23 °F to 122 °F)
Outdoor Range	-20 °C to 60 °C (-4 °F to 140 °F)
Resolution	0.1 °C (0.2° F)
Memory	Min / Max

REMOTE SENSOR

RF frequency	433 MHz
Range	30 meters (98 feet) with no obstructions
Transmission	every 78 seconds

CLOCK

Atomic Clock	Auto or manual (disabled)
Clock display	HH:MM:SS
Hour format	12hr AM/PM or 24hr
Hour offset	+/- 9 hours
Calendar	MM/DD; weekday in 5 languages (D, E, F, I, S)
Alarm	Weekday and Single; 2- minute crescendo

POWER

Main unit batteries	2 x UM-4 (AAA) 1.5V alkaline
Sensor batteries	2 x UM-3 (AA) 1.5V alkaline





FCC STATEMENT

This device complies with Part 15 of the FCC Rules. Operation is subject to the following two conditions:
(1) This device may not cause harmful interference, and
(2) This device must accept any interference received, including interference that may cause undesired operation.

Warning: Changes or modifications to this unit not expressly approved by the party responsible for compliance could void the user's authority to operate the equipment.

NOTE: This equipment has been tested and found to comply with the limits for a Class B digital device, pursuant to Part 15 of the FCC Rules. These limits are designed to provide reasonable protection against harmful interference in a residential installation. This equipment generates, uses and can radiate radio frequency energy and, if not installed and used in accordance with the instructions, may cause harmful interference to radio communications.

However, there is no guarantee that interference will not occur in a particular installation. If this equipment does cause harmful interference to radio or television reception, which can be determined by turning the equipment off and on, the user is encouraged to try to correct the interference by one or more of the following measures:

- 
- 
- Reorient or relocate the receiving antenna.
 - Increase the separation between the equipment and receiver.
 - Connect the equipment into an outlet on a circuit different from that to which the receiver is connected.
 - Consult the dealer or an experienced radio/TV technician for help.

EN

DECLARATION OF CONFORMITY

The information below is not to be used as contact for support or sales. Please call our customer service number (listed on our website at www.oregonscientific.com, or on the warranty card for this product) for all inquiries instead.

We

Name: Oregon Scientific, Inc.
Address: 19861 SW 95th Place, Tualatin,
Oregon 97062 USA
Telephone No.: 1-800-853-8883
Fax No.: 1-503-684-8883

declare that the product

Product No.: RMR602A
Product Name: Wireless Thermo Clock
Manufacturer: IDT Technology Limited
Address: Block C, 9/F, Kaiser Estate,
Phase 1, 41 Man Yue St.,
Hung Hom, Kowloon,
Hong Kong

is in conformity with Part 15 of the FCC Rules. Operation is subject to the following two conditions:

- 1) This device may not cause harmful interference.
- 2) This device must accept any interference received, including interference that may cause undesired operation.



© 2004 Oregon Scientific. All rights reserved.

P/N.: 086-003350-010



RMR602A lab test back cover

1

Black



12/29/03, 10:23 PM