



Instruction Manual For Baldor Grinders

SAFETY NOTICE:

WARNING statements describe conditions that may lead to personnel injury including potentially fatal injuries if the machine is not properly used and warnings are not properly followed.

Caution statements describe conditions that may lead to equipment damage.

Electrical shock can cause serious or fatal injury. Only qualified personnel should install, maintain or troubleshoot this equipment.

- WARNING:** Do not operate this grinder until you are sure that you are completely familiar with the safe operation of the grinder, all accessories and safety equipment. Improper use can lead to severe injury. This manual defines proper use of this equipment. Before using this equipment for any other use, please consult Baldor. Contact Baldor if you do not understand any procedure or operation concerning this grinder or this manual.
- WARNING:** Prevent electrical shock hazard and accidental machine operation. Always disconnect grinder from the power source before servicing, changing accessories (such as wheels, tool rest, spark arrestor, etc.) or before performing maintenance.
- WARNING:** Avoid accidental starting. Make sure switch is in “OFF” position before connecting to power source.
- WARNING:** Be sure the system is properly grounded before applying power. Do not apply power before you ensure that grounds are connected. Electrical shock can cause serious or fatal injury. Follow the National Electrical Code (NEC) and local codes for the safe installation of this equipment.
- WARNING:** Always use safety glasses with side shields (or full face shield) when operating grinder. Do not use ordinary eyeglasses. Also use face or dust mask if cutting operation is dusty.
- WARNING:** Unsuitable accessories or attachments added to this machine can create hazards. Baldor accessories are specifically designed to be used with this grinder. Use accessories or attachments only in the proper intended manner. Accessories or attachments obtained from another source may cause hazards. Consult the manufacturer before use.
- WARNING:** Keep guards in place and in working order. Guards are design to prevent injury. Never operate this equipment if a guard is damaged, missing or improperly installed.
- WARNING:** Remove adjusting keys and wrenches from this product after use. Check to see that keys and adjusting wrenches are removed from grinder before turning it on. Projectiles can cause severe injury to yourself or others.
- WARNING:** Keep work area clean and well lighted. Clutter and poor lighting invites accidents.
- WARNING:** Don't use in dangerous environment. Don't use grinders in damp or wet locations, or expose them to rain. Electrical shock can cause serious or fatal injury. Follow the National Electrical Code (NEC) and local codes for the safe installation of this equipment.
- WARNING:** Do not wear loose clothing, neckties, rings, bracelets, or other jewelry to get caught in moving parts. Nonslip footwear is recommended. Wear protective hair covering to contain long hair.
- WARNING:** Don't over reach. Keep proper footing and balance at all times. A rotating wheel or belt can catch an article of clothing and cause personnel injury.
- WARNING:** Secure work. Use clamps to secure the work piece when practical. It's safer than using your hand and it keeps hands away from wheel.
- WARNING:** When starting a grinder for the first time, or after installing a replacement grinding wheel, it is most important that the operator stand aside for at least one minute of rotation at full speed. This is the correct practice since grinding wheels can disintegrate if they have received damage during shipping or handling.
- WARNING:** Always have the grinder switch in the “OFF” position when changing the position of the pivot arm. Do not attempt to change the pivot arm position while the belt is moving as this will create a hazardous situation for the operator.

SAFETY NOTICE Continued

- WARNING:** Never install a wheel that is damaged, such as a chip or crack on any surface. A damaged wheel can disintegrate while rotating at a high RPM or when work is placed against the wheel. This can severely harm the operator or others in the area.
- WARNING:** Check damaged parts. Before further use of the grinder, a guard or other part that is damaged should be carefully checked to assure that it will operate properly and perform its intended function. Check for alignment of moving parts, binding of moving parts, breakage of parts, mounting, and any other conditions that may affect its operation. A guard or other part that is damaged should be properly repaired or replaced.
- WARNING:** Use proper extension cord. Make sure your extension cord is in good condition. When using an extension cord, be sure it is rated for the voltage and current rating of your product. An undersized cord will cause a drop in line voltage resulting in loss of power and overheating. Table 1 shows the correct wire size to use depending on cord length and nameplate ampere rating. If in doubt, use the next heavier gauge. The smaller the AWG gauge number, the heavier the cord.
- WARNING:** Dust created during grinding, sawing, power sanding, drilling, and other activities may contain chemicals known to the State of California to cause cancer, birth defects or other reproductive harm.
- WARNING:** Keep children and visitors away. Remove starter keys turn off master switches. Padlock equipment or work area when not in use.
- WARNING:** Never leave grinder running unattended. Always turn power off after use.
- Caution:** Don't force grinder. It will do the job better and safer at the feed rate for which it was designed.
- Caution:** Use right tool. Don't force tool or attachment to do a job for which it was not designed.
- Caution:** Maintain grinder with care. Keep grinder clean for best and safest performance.

Always use guard and eyeshield. Operating the grinder without the guard and eyeshield or with damaged guard and eyeshield must not be attempted because of the hazard this introduces.

Do not overtighten wheel nut. A damaged grinding wheel can disintegrate in all directions. An overtightened wheel nut can stress the grinding wheel and cause it to disintegrate during operation. Wheel nut should be tightened just enough to prevent grinding wheel from slipping on shaft when grinding. Use only flanges furnished with this grinder. The flanges furnished with the grinder are designed to grip the grinding wheel without introducing excessive stresses in the wheel.

Replace a cracked or chipped wheel immediately. A cracked wheel will disintegrate when operated, causing a hazard to operator and nearby personnel. If a wheel has a chip or crack on any surface, do not use it.

Maintain $\frac{1}{8}$ " or less clearance between tool rest and wheel. This clearance is necessary to prevent the work piece from becoming wedged between the wheel and tool rest and restricting nip areas in the machine.

Grind on grinding face (periphery) of wheels only. Grinding on side of wheel weakens the wheel and may cause wheel breakage. Also, grinding on the side of wheel introduces an additional hazard due to absence of a tool rest.

SAFETY NOTICE Continued

Use wheels rated at or over rated grinder RPM shown in the following table.

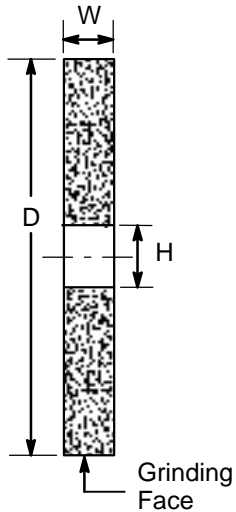

Grinder Wheel

"D" Diameter (inches)	Wheel Size		No Load RPM (on Nameplate)
	"W" Width (inches)	"H" Arbor Diameter (inches)	
6"	3/4"	1/2"	1800
6"	3/4"	1/2"	3600
7"	1"	5/8"	1800
7"	1"	5/8"	3600
8"	1"	3/4"	1800
8"	1"	3/4"	3600
10"	1"	7/8"	1800
12"	2"	1-1/4"	1800
14"	3"	1-1/4"	1800

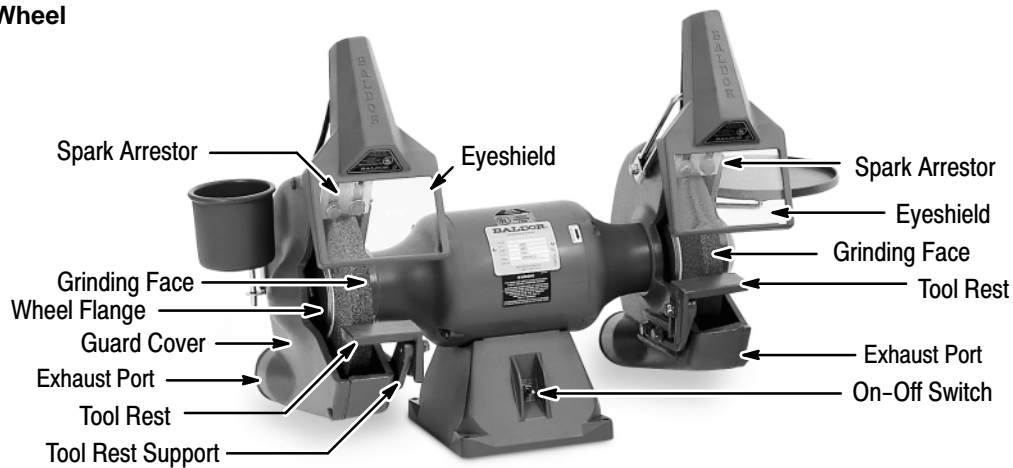

Installation

When you receive your unit, there are several things you should do immediately.

1. Observe the condition of the shipping container and report any damage immediately to the commercial carrier that delivered the product.
2. Verify that the part number you received is the same as the part number listed on your purchase order.

WARNING:

When starting a grinder for the first time, or after installing a replacement grinding wheel, it is most important that the operator stand aside for at least one minute of rotation at full speed. This is the correct practice since grinding wheels can disintegrate if they have received damage during shipping or handling.

3. Mount grinder on solid bench. The grinder must be securely bolted to a rigid mounting surface. If a pedestal is used, first bolt pedestal securely to floor and then bolt grinder to pedestal.
4. Check grinder nameplate to make certain the rating is correct for the power source, voltage and frequency. See electrical and grounding instructions for electrical service connection.
5. Adjust spark arrestor for approximately 1/16" clearance between it and grinding wheel. Maintain 1/8" or less clearance between spark arrestor and wheel as wheel wears.
6. Adjust angle of tool rest on support to desired position and tighten nut securely. Adjust tool rest support on guard to attain approximately 1/16" clearance between tool rest and grinding wheel and tighten nut securely. Maintain 1/8" or less clearance between tool rest and wheel.
7. Adjust eyeshield to position aligning center of eyeshield in line of sight to tool rest.

Electrical Instructions

Single phase grinders are rated dual voltage. Some single phase grinders are equipped with cord and grounding type plug for 115 volts. To use with a different voltage, see instructions provided to make wiring changes. All attachment plugs and any receptacles must be replaced with devices rated for the voltage for which the grinder is reconnected. Table 1 indicates the minimum wire size. Be sure to comply with NEC and local wiring codes.

Three phase grinders are normally dual voltage and must be wired for the proper voltage and rotation direction (connections are inside conduit box). Connect phase sequence so that the wheel moves down toward top surface of tool rest as viewed from front of grinder. Wheel must rotate toward tool rest. Be sure all electrical connections are secured and properly insulated. For your safety, be certain grinder is properly grounded.

Grounding Instructions

WARNING: **Be sure the system is properly grounded before applying power. Do not apply power before you ensure that grounds are connected. Electrical shock can cause serious or fatal injury. Follow the National Electrical Code (NEC) and local codes for the safe installation of this equipment.**

1. **All grounded, cord-connected grinders:**

In the event of a malfunction or breakdown, grounding provides a path of least resistance for electric current to reduce the risk of electric shock. This grinder is equipped with an electric cord having an equipment-grounding conductor and a grounding plug. The plug must be plugged into a matching outlet that is properly installed and grounded in accordance with all local codes and ordinances. Do not modify the plug provided. If it will not fit the outlet, have the proper outlet installed by a qualified electrician.

Improper connection of the equipment-grounding conductor can result in a risk of electric shock. The "Green" insulated wire (with or without yellow stripes) is the equipment-grounding conductor. If repair or replacement of the electric cord is necessary, do not connect the equipment-grounding conductor to a live terminal. Check with a qualified electrician or serviceman if the grounding instructions are not completely understood, or if in doubt as to whether the tool is properly grounded.

Use only 3-wire extension cords that have 3-prong grounding plugs and 3-pole receptacles that accept the tool's plug.

Repair or replace damaged or worn cord immediately.

2. Grounded, cord-connected grinders intended for use on a supply circuit having a nominal rating less than 150 volts:

This grinder is intended for use on a circuit that has an outlet that looks like the one illustrated in Figure A. The tool has a grounding plug that looks like the plug illustrated in Figure A. A temporary adapter, which looks like the adapter illustrated in Figures B and C, may be used (except in Canada) to connect this plug to a 2-pole receptacle as shown in Figure B if a properly grounded outlet is not available. The temporary adapter should be used only until a properly grounded outlet can be installed by a qualified electrician. The green-colored rigid ear, lug, etc. extending from the adapter must be connected to a permanent ground such as a properly grounded outlet box.

3. Grounded, cord-connected tools intended for use on a supply circuit having a nominal rating between 150–250 volts, inclusive:

This grinder is intended for use on a circuit that has an outlet that looks like the one illustrated in Figure D. The grinder has a grounding plug that looks like the plug illustrated in Figure D. Make sure the grinder is connected to an outlet having the same configuration as the plug. No adapter is available, or should be used, with this grinder. If the grinder must be reconnected for use on a different type of electric outlet, the reconnection should be made by qualified service personnel; and after reconnection, the grinder should comply with all local codes and ordinances.

Grounding Instructions Continued

4. Permanently connected grinders:
This grinder should be connected to a grounded, metal, permanent wiring system; or to a system having an equipment-grounding conductor.

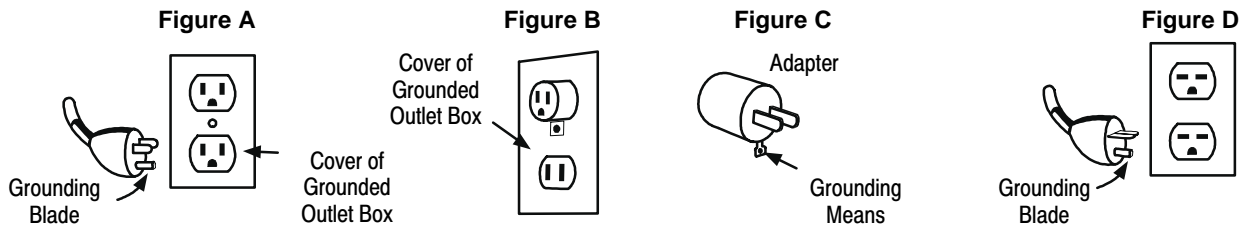

Operation

WARNING: Do not operate this grinder until you are sure that you are completely familiar with the safe operation of the grinder, all accessories and safety equipment. Improper use can lead to severe injury. This manual defines proper use of this equipment. Before using this equipment for any other use, please consult Baldor. Contact Baldor if you do not understand any procedure or operation concerning this grinder or this manual.

WARNING: When starting a grinder for the first time, or after installing a replacement grinding wheel, it is most important that the operator stand aside for at least one minute of rotation at full speed. This is the correct practice since grinding wheels can disintegrate if they have received damage during shipping or handling.

Check that the On-Off switch is in the "OFF" position, and the grinding wheel and wheel move freely. When starting the grinder for the first time or after replacing a wheel, it is important that the operator stand aside for at least one minute of operation at speed. This will ensure that operation will be safe from debris. After connecting grinder to power source, turn switch on. Grinder should come up to speed smoothly and without vibration. If grinder does not, shut grinder off immediately and determine reason.

As grinding wheel wears, maintain $\frac{1}{8}$ " or less clearance between tool rest and grinding wheel and spark arrestor and grinding wheel.

Grind on grinding face (periphery) of wheels only.

Maintenance

WARNING: Prevent electrical shock hazard and accidental machine operation. Always disconnect grinder from the power source before servicing, changing accessories (such as wheels, tool rest, spark arrestor, etc.) or before performing maintenance.

WARNING: Never install a wheel that is damaged, such as a chip or crack on any surface. A damaged wheel can disintegrate while rotating at a high RPM or when work is placed against the wheel. This can severely harm the operator or others in the area.

Replace worn grinding wheel as necessary. The grinding wheel should be replaced after the diameter is reduced by 2 inches from original size. When replacing a worn wheel, remove all grinding dust from wheel guard.

Motor and pulley bearings are lubricated for life and do not require additional lubrication.

Replacement wheels may be purchased directly from your local industrial supply dealers, abrasive dealers, tool dealers, etc.

Remove grinding dust from exhaust ports to prevent accumulation.

Replace damaged parts immediately to maintain safety of machine.

Table 1 Minimum Gauge Wire Size

Ampere Rating		Volts	Total Length of Cord (Cord + Extension, in Feet)			
		115V	25	50	100	150
		230V	50	100	200	300
More Than	Not More Than	AWG				
0	6		18	16	16	14
6	10		18	16	14	12
10	12		16	16	14	12
12	16		14	12	Not Recommended	

LIMITED WARRANTY

Unless otherwise provided, Baldor grinders are warranted against defects in Baldor workmanship and materials for a period of Thirty-Six months. All warranty claims must be submitted to a Baldor repair facility prior to the expiration of the warranty period. Baldor shall have no responsibility or liability for any defect, latent or otherwise, discovered after the expiration of the warranty period provided herein. Extended warranties are available for certain Baldor products. These warranties are described in Baldor's catalog and other sales literature. Extended warranties are subject to the terms and conditions of this Limited Warranty as modified by the additional terms of the extended warranty. If a Baldor product is defective due to Baldor workmanship or materials and the defect occurs during the warranty period, then Baldor will either repair the product or replace it with a new one, whichever Baldor believes to be appropriate under the circumstances. Warranty service is available for all Baldor products from Baldor's Customer Service Department in Fort Smith, Arkansas, and from Baldor repair facilities. A list of Baldor's repair facilities may be obtained by contacting Baldor at: Baldor Electric Company, 5711 R.S. Boreham, Jr. St., Fort Smith, Arkansas, 479-646-4711 (phone), 479-648-5792 (fax). All Baldor products requiring warranty service shall be transported or shipped freight pre-paid, at the risk of the party requiring warranty service, to Baldor's Customer Service Department in Fort Smith, Arkansas or to a Baldor repair facility. Written notification of the alleged defect in addition to a description of the manner in which the Baldor grinder is used, and the name, address and telephone number of the party requiring warranty service must be included. Baldor is not responsible for removal and shipment of the Baldor product to the service center nor for the reinstallation of the Baldor product upon its return to the party requiring warranty service. Customers who are unable to take or ship the Baldor product to a Baldor repair facility, or who desire a repair to be made by other than a Baldor repair facility, should contact Baldor's Customer Service Department at 479-646-4711. Repair by anyone other than a Baldor repair facility must be approved in writing by Baldor in advance of such service. Problems with Baldor products can be due to improper maintenance, faulty installation, non-Baldor additions or modifications, or other problems not due to defects in Baldor workmanship or materials. If a Baldor repair facility determines that the problem with a Baldor product is not due to defects in Baldor workmanship or materials, then the party requiring warranty service will be responsible for the cost of any necessary repairs. Parties requiring warranty service not satisfied with a determination that a problem is outside of warranty coverage should contact Baldor's Customer Service Department at 479-646-4711 for further consideration.

EXCEPT FOR THE EXPRESS WARRANTY SET FORTH ABOVE, BALDOR DISCLAIMS ALL OTHER EXPRESS AND IMPLIED WARRANTIES INCLUDING THE IMPLIED WARRANTIES OF FITNESS FOR A PARTICULAR PURPOSE AND MERCHANTABILITY. NO OTHER WARRANTY, EXPRESS OR IMPLIED, WHETHER OR NOT SIMILAR IN NATURE TO ANY OTHER WARRANTY PROVIDED HEREIN, SHALL EXIST WITH RESPECT TO THE GOODS SOLD UNDER THE PROVISIONS OF THESE TERMS AND CONDITIONS. ALL OTHER SUCH WARRANTIES ARE HEREBY EXPRESSLY WAIVED BY THE BUYER. UNDER NO CIRCUMSTANCES SHALL BALDOR BE LIABLE OR RESPONSIBLE IN ANY MANNER WHATSOEVER FOR ANY INCIDENTAL, CONSEQUENTIAL OR PUNITIVE DAMAGES, OR ANTICIPATED PROFITS RESULTING FROM THE DEFECT, REMOVAL REINSTALLATION, SHIPMENT OR OTHERWISE.

This is the sole warranty of Baldor and no other affirmations or promises made by Baldor shall be deemed to create an express or implied warranty. Baldor has not authorized anyone to make any representations or warranties other than the warranty contained herein.



P.O. Box 2400 Ft. Smith, AR 72902-2400
(479) 646-4711 Fax (479) 648-5792
www.baldor.com