

PARTS MANUAL

Model

R1210

Generator

PUB-GP0724
Rev. 8/98

HOW TO USE THIS PARTS CATALOG

1. Reference numbers with an asterisk



Reference numbers marked with an asterisk indicate that the particular part is available only as a complete set or assembly.

Example :

If the reference number is marked with an asterisk and the description of the part states that certain items are included, this means that those included items cannot be ordered separately and must be purchased as a complete assembly.

2. Description of interchangeability and execution columns



Example : Interchangeability column

-  Items interchangeable between the new and old parts.
-  Items not interchangeable between the new and old parts.
-  Items conditionally interchangeable between the new and old parts which are subject to the description in the execution column.

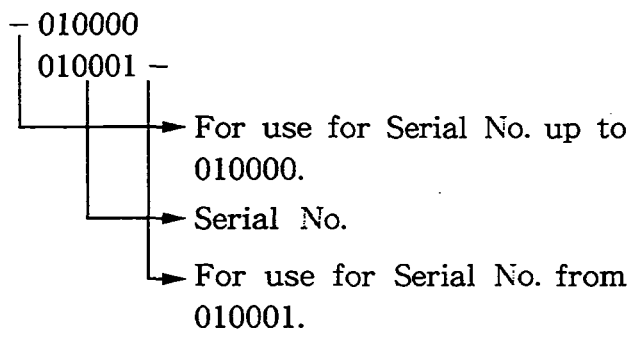
Example : Execution column



Example : Interchangeable

Part Number		Execution	Explanation
Part B Part A		020000 -	This indicates that Part A changed to Part B for generators with serial numbers from 20000, and that they are interchangeable.
Part C Part B Part A		020000 - 015000 -	This indicates that Part A changed to Part B for generators with serial numbers from 15000, and that they are not interchangeable. Also, Part B changed to Part C for generators with serial numbers from 20000 and that they are interchangeable.
Part A		020000 -	This indicates that Part A is a new part for generators with serial numbers with from 20000.
Part B		- 030000	This indicates that Part B is no longer used for generator with serial numbers from 30001.
Part B Part A		020000 -	This indicates that Part A changed to Part B for generators with serial numbers from 20000, and that they are conditionally interchangeable. (See NOTE described at the end of the section.)

3. The contents of this parts catalog are subject to revision without notice.
To INSURE PROMPT AND ACCURATE SERVICE, ALSO THE FOLLOWING INFORMATION MUST BE GIVEN.

1. State exactly the quantity of each part and its part numbers.
2. Clearly state whether parts are to be shipped by express, freight or parcel post.
3. State the exact mailing address.

CONTENTS

	Page
GENERATOR PARTS	
FIG. 1 FUEL TANK.....	1
FIG. 2-1 CONTROL PANEL (STD RECEPTACLE TYPE).....	3
FIG. 3 GENERATOR.....	15
FIG. 4 COVER.....	17
 ENGINE PARTS	
FIG. 5-1 CRANKCASE (WITHOUT OIL SENSOR).....	19
FIG. 5-2 CRANKCASE (WITH OIL SENSOR).....	21
FIG. 6 CRANKSHAFT, PISTON and CAMSHAFT.....	23
FIG. 7 GOVERNOR.....	25
FIG. 8 BLOWER HOUSING and MUFFLER.....	27
FIG. 9 AIR CLEANER and CARBURETOR.....	29
FIG. 10 MAGNETO.....	31
FIG. 11 RECOIL STARTER.....	33

FIG. 1 FUEL TANK

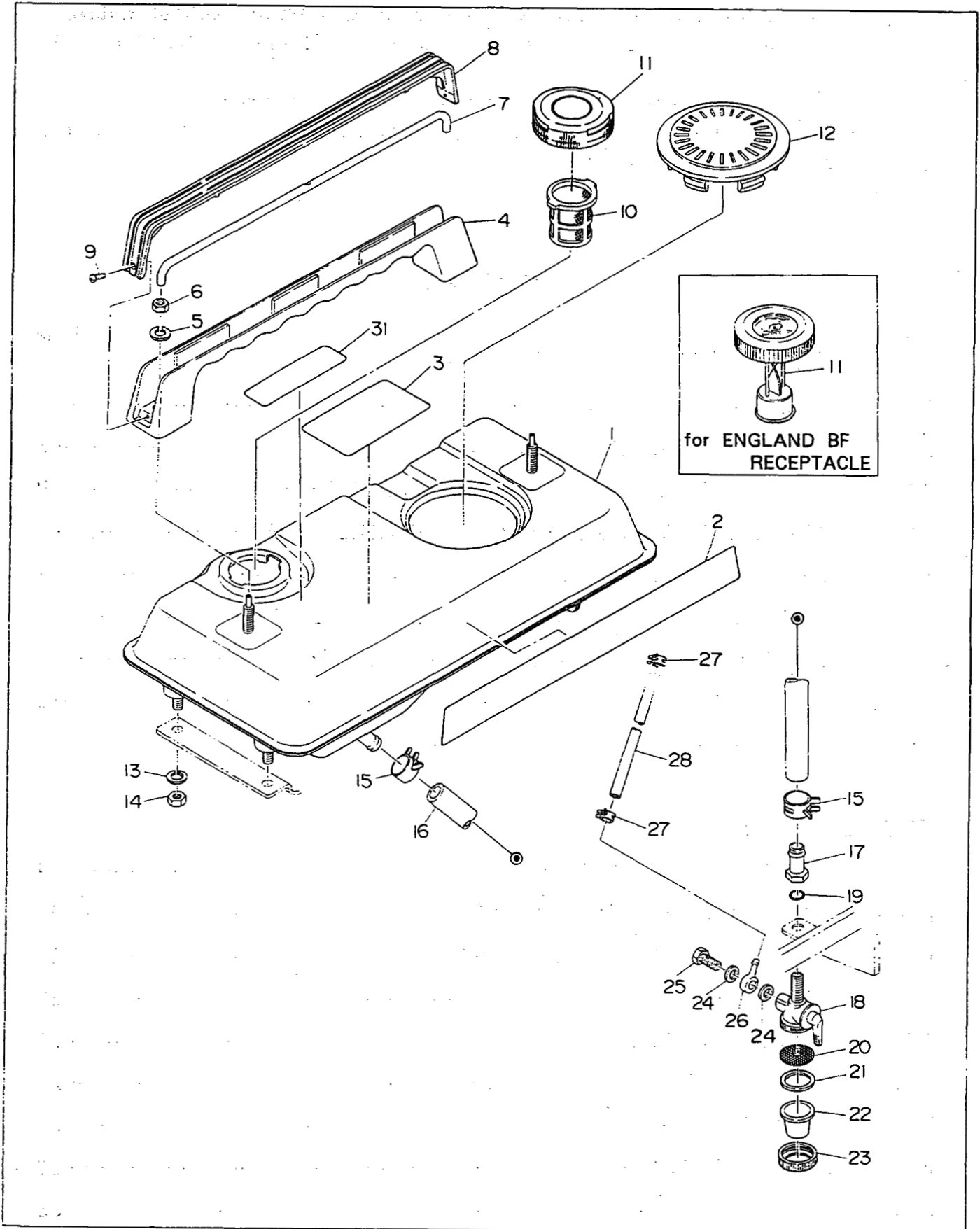

FIG. 2-1 CONTROL PANEL (STD RECEPTACLE TYPE)

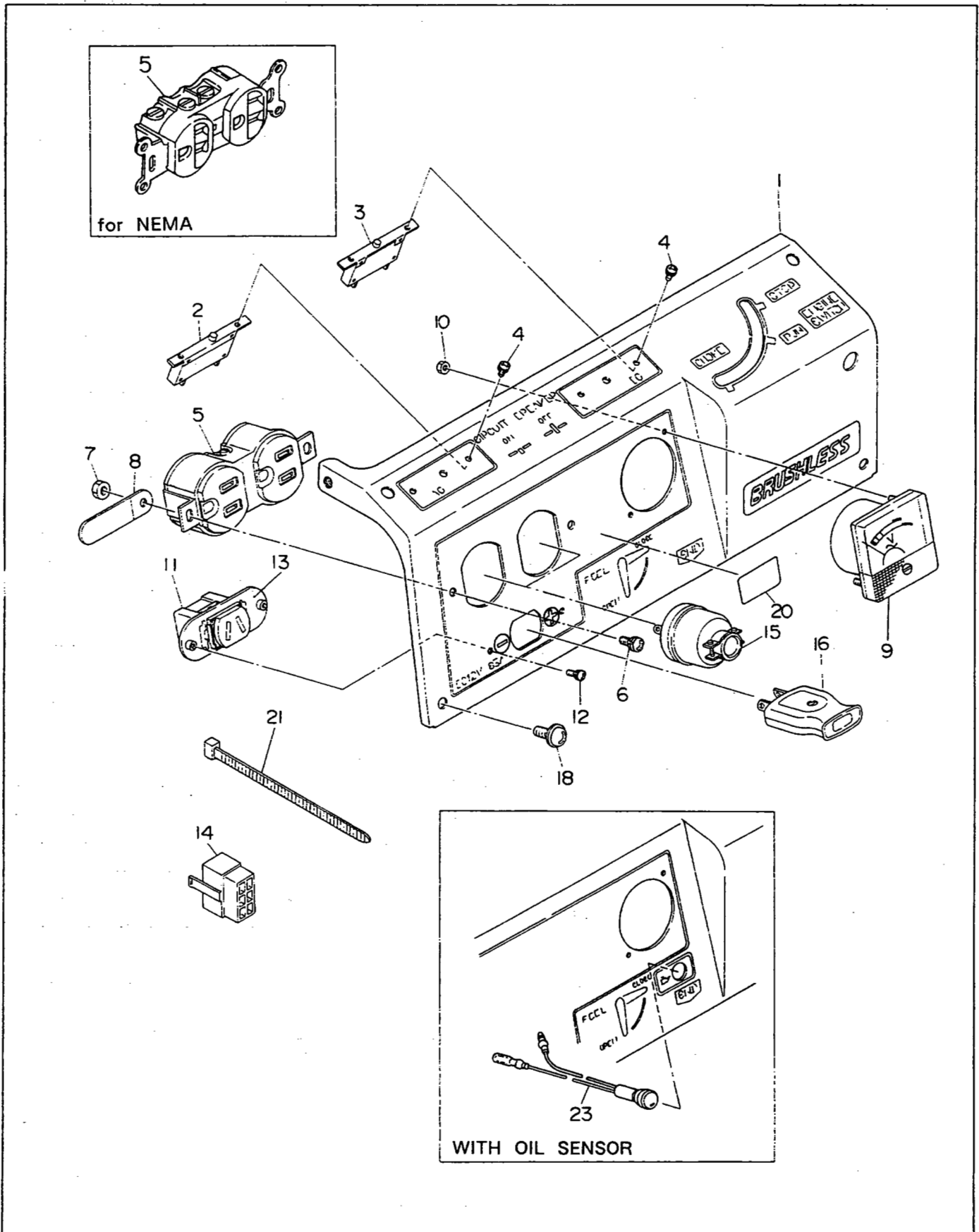

FIG. 2-1 CONTROL PANEL (STD RECEPTACLE TYPE)

Ref. No.	Parts Number	Description	Qty	r Interchangeability	
					Execution
1	350-41802-01	CONTROL PANEL, compl.	1		
1	350-41808-01	CONTROL PANEL, compl. for CHINA, 50Hz-220V	1		
1	350-42502-01	CONTROL PANEL, compl. with oil sensor for 60Hz-110V	1		
2	351-45624-08	CIRCUIT BREAKER (AC) for 8A, 50Hz-110V, 60Hz-120V	1		
2	352-45620-08	CIRCUIT BREAKER (AC) for 10A, 60Hz-110V	1		
2	350-40605-08	CIRCUIT BREAKER (AC) for 5A, 60Hz-220V	1		
2	376-42001-08	CIRCUIT BREAKER (AC) for 3.15A, 50Hz-240V	1		
2	377-42000-08	CIRCUIT BREAKER (AC) for 3.5A, 50Hz-220V, 230V	1		
3	352-45620-08	CIRCUIT BREAKER (DC) for 10A	1		
4	004-35030-60	SCREW and WASHER ASS'Y	4		
5	378-45736-08	AC RECEPTACLE, 250V-15A	1		
5	378-45737-08	AC RECEPTACLE, 125V-15A	1		
5	356-45712-08	AC RECEPTACLE, for NEMA, 125V-15A	1		
6	004-35041-00	SCREW and WASHER ASS'Y	2		
7	002-17040-00	NUT	2		
8	350-21053-08	CLAMP	1		
9	391-47800-01	AC VOLTMETER, for 110, 120V	1		
9	391-47900-01	AC VOLTMETER, for 220, 230, 240V	1		
10	002-17030-00	NUT	2		
11	350-40602-08	DC RECEPTACLE, 250V-10A	1		
12	004-35030-80	SCREW and WASHER ASS'Y	2		
13	350-40603-08	DC RECEPTACLE BASE	1		
14	353-54300-08	CONNECTOR (6P)	1		
15	358-95001-03	AC PLUG, RECEPTACLE for 250V-15A	2		
15	358-95002-03	AC PLUG, RECEPTACLE for 125V-15A	2		
16	358-95003-03	DC PLUG	1		
18	013-10500-20	SCREW and WASHER ASS'Y	4		
20	350-95101-03	LABEL (50Hz-220V)	1		
20	350-95102-03	LABEL (50Hz-230V)	1		
20	350-95103-03	LABEL (50Hz-240V)	1		
20	350-95104-03	LABEL (50Hz-110V)	1		
20	350-95107-03	LABEL (60Hz-110V)	1		
20	350-95108-03	LABEL (60Hz-120V)	1		
20	350-95109-03	LABEL (60Hz-220V)	1		
21	056-30000-20	WIRE BAND	3		
23	227-77002-00	LED LAMP ASS'Y, for oil sensor	1		

FIG. 3 GENERATOR

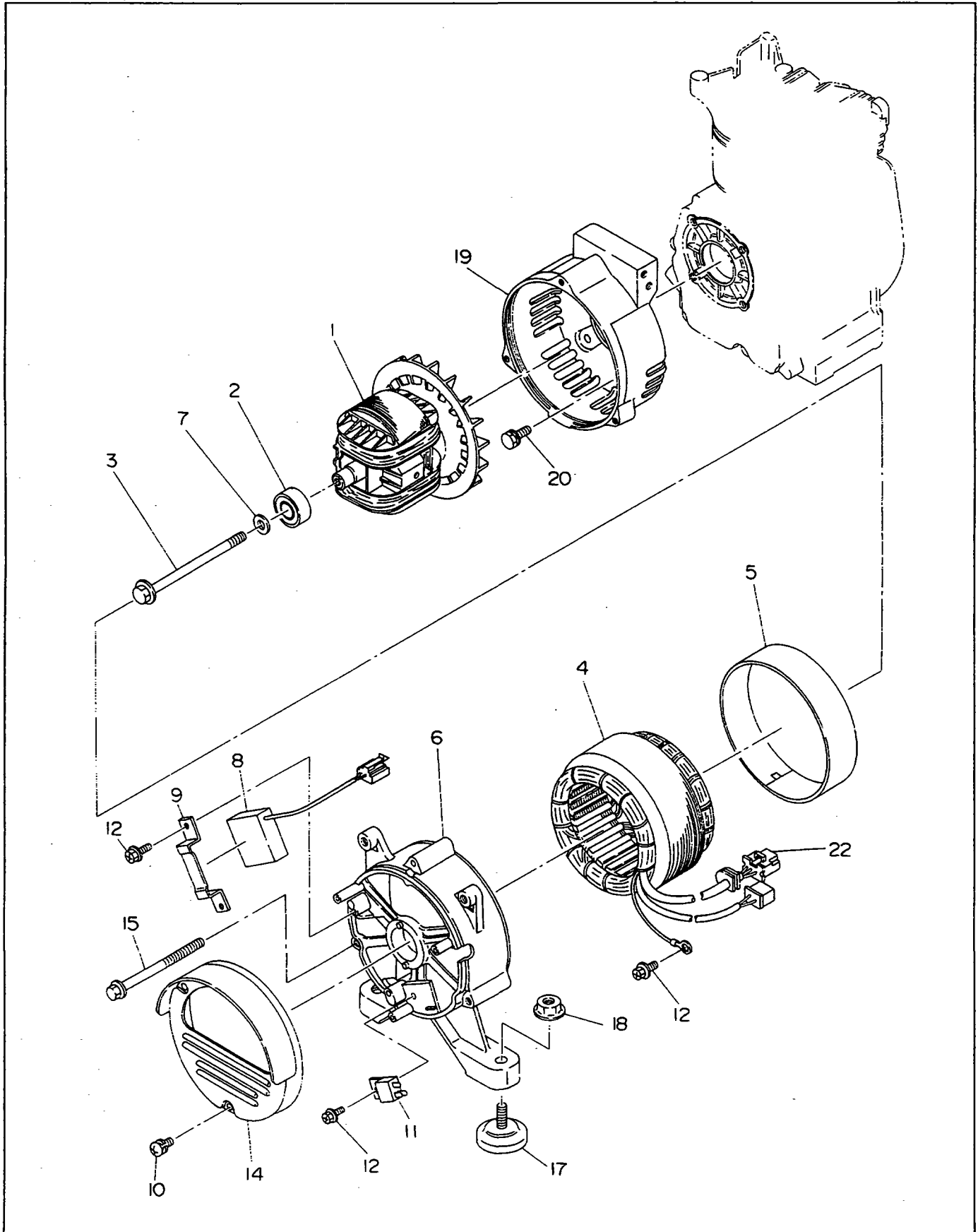

FIG. 4 COVER

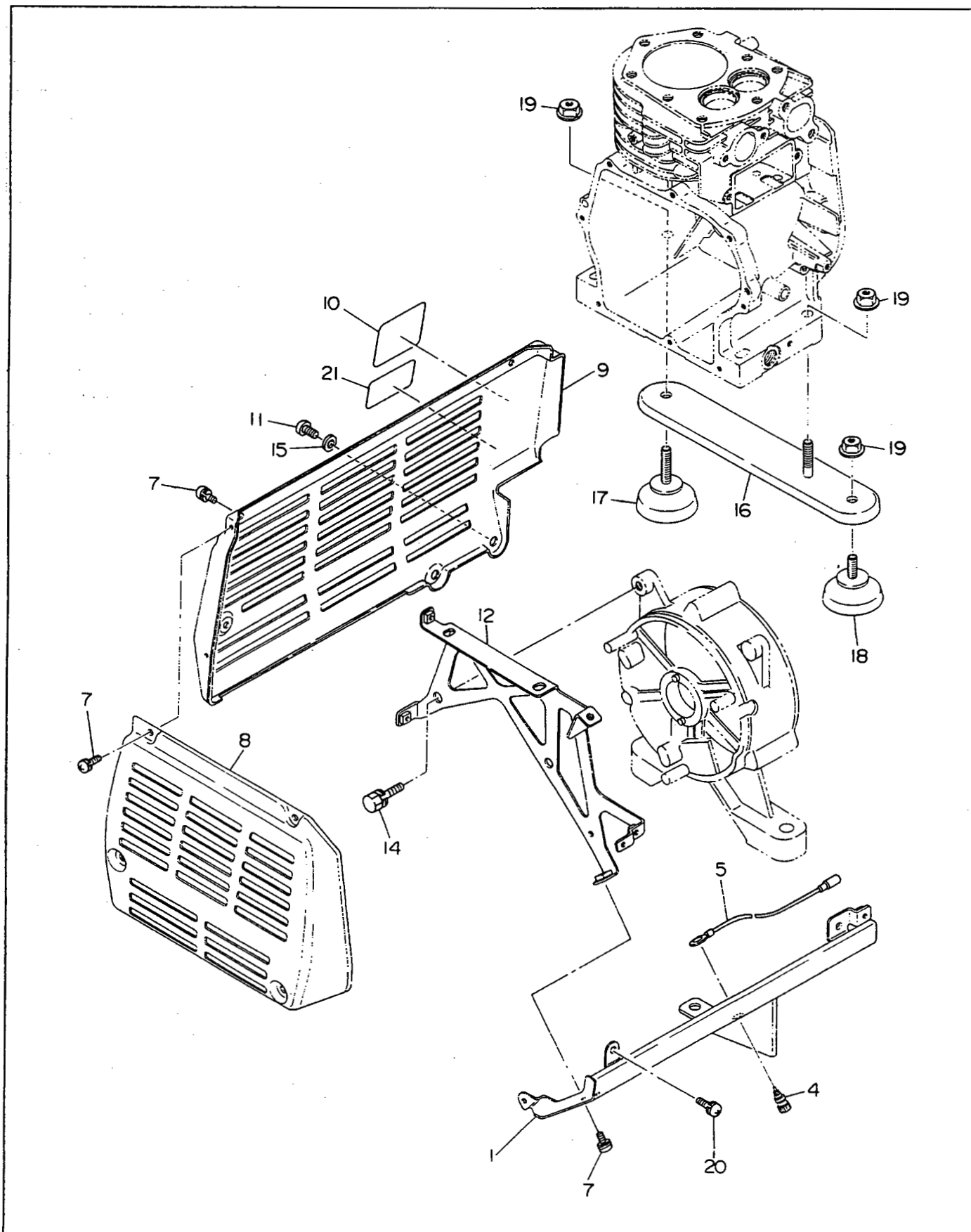

FIG. 5-1 CRANKCASE (WITHOUT OIL SENSOR)

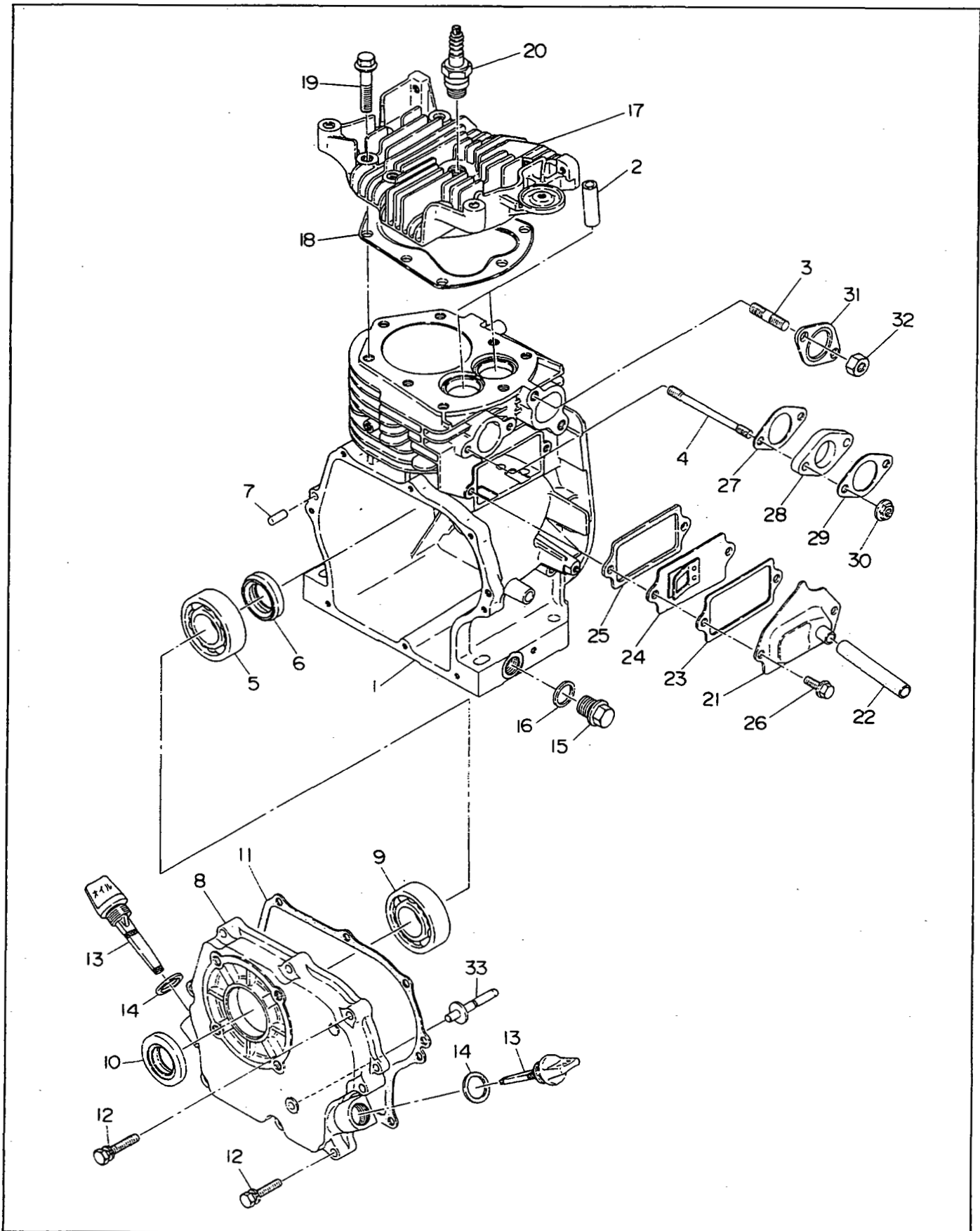

FIG. 5-2 CRANKCASE (WITH OIL SENSOR)

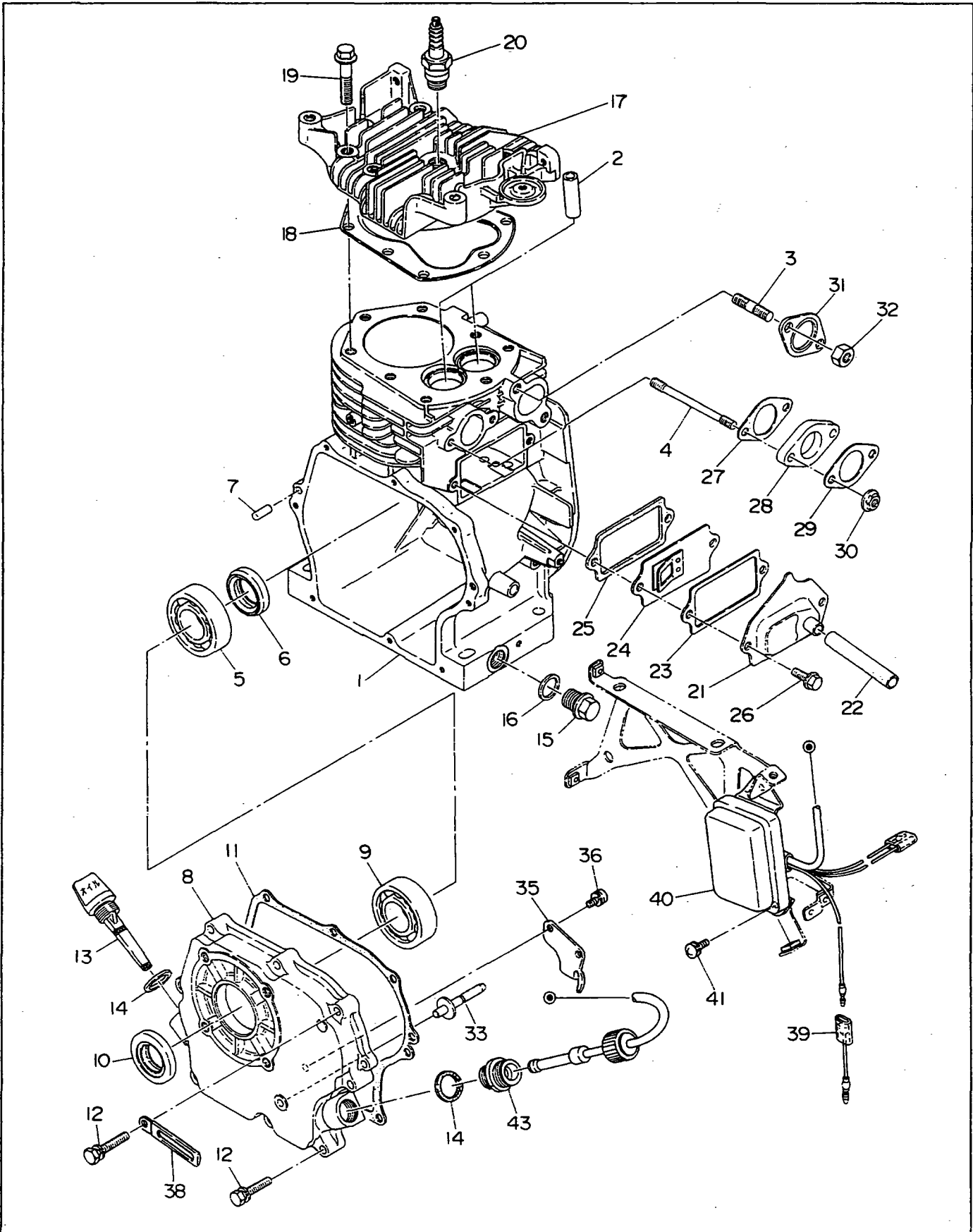

FIG. 5-2 CRANKCASE (WITH OIL SENSOR)

Ref. No.	Parts Number	Description	Q'ty	Execution
* 1	226-10101-21	CRANKCASE, compl. Includes items 2 thru 7	1	
2	227-14202-03	VALVE GUIDE, over size	2	
3	010-50802-50	STUD	2	
4	010-50601-20	STUD	2	
5	060-02500-10	BALL BEARING (BB-6205C3)	1	
6	044-02501-50	OIL SEAL (TB-25 ϕ \times 38 ϕ \times 7)	1	
7	031-00600-20	DOWEL PIN	2	
* 8	227-11006-01	MAIN BEARING COVER, compl. Includes items 9,10 and 33	1	
9	060-02500-10	BALL BEARING (BB-6205C3)	1	
10	044-02501-60	OIL SEAL (TB-25 ϕ \times 41.24 ϕ \times 7.3)	1	
11	227-16001-03	GASKET, bearing cover	1	
12	013-00600-40	BOLT and WASHER ASS'Y	8	
13	227-63601-03	OIL GAUGE	1	
14	021-31600-10	GASKET	2	
15	040-11400-30	PLUG	2	
16	021-11400-20	GASKET	2	
17	226-13101-13	CYLINDER HEAD	1	
18	226-15001-11	GASKET, compl. head	1	
19	011-00800-10	FLANGE BOLT	8	
20	065-01401-50	SPARK PLUG (NGK BR6HS)	1	
21	227-14301-01	TAPPET COVER, compl.	1	
22	085-10800-00	RUBBER PIPE (8 ϕ \times 11 ϕ \times 75mm)	1	
23	227-16006-03	GASKET, tappet cover	1	
24	227-14401-01	BREATHER PLATE, compl.	1	
25	227-16007-03	GASKET, breather plate	1	
26	011-00600-20	FLANGE BOLT	2	
27	227-35901-03	GASKET, insulator	1	
28	227-32901-13	INSULATOR	1	
29	227-35904-03	GASKET 2, insulator	1	
30	002-38060-00	FLANGE NUT	2	
31	226-35201-01	GASKET, compl. exhaust	1	
32	002-19080-00	NUT	2	
35	227-17501-03	OIL SHELTER	1	
36	004-35040-80	SCREW and WASHER ASS'Y	2	
38	056-60002-50	CLAMP	1	
39	214-73122-01	WIRE 22, compl.	1	
40	227-76015-01	OIL LEVEL SENSOR, compl.	1	
41	004-36061-20	SCREW and WASHER ASS'Y	2	
43	227-76210-03	JOINT	1	
*	226-99001-07	GASKET SET, Includes items 11,14,18,23,25,27,29 and 31	1	

FIG. 6 CRANKSHAFT, PISTON and CAMSHAFT

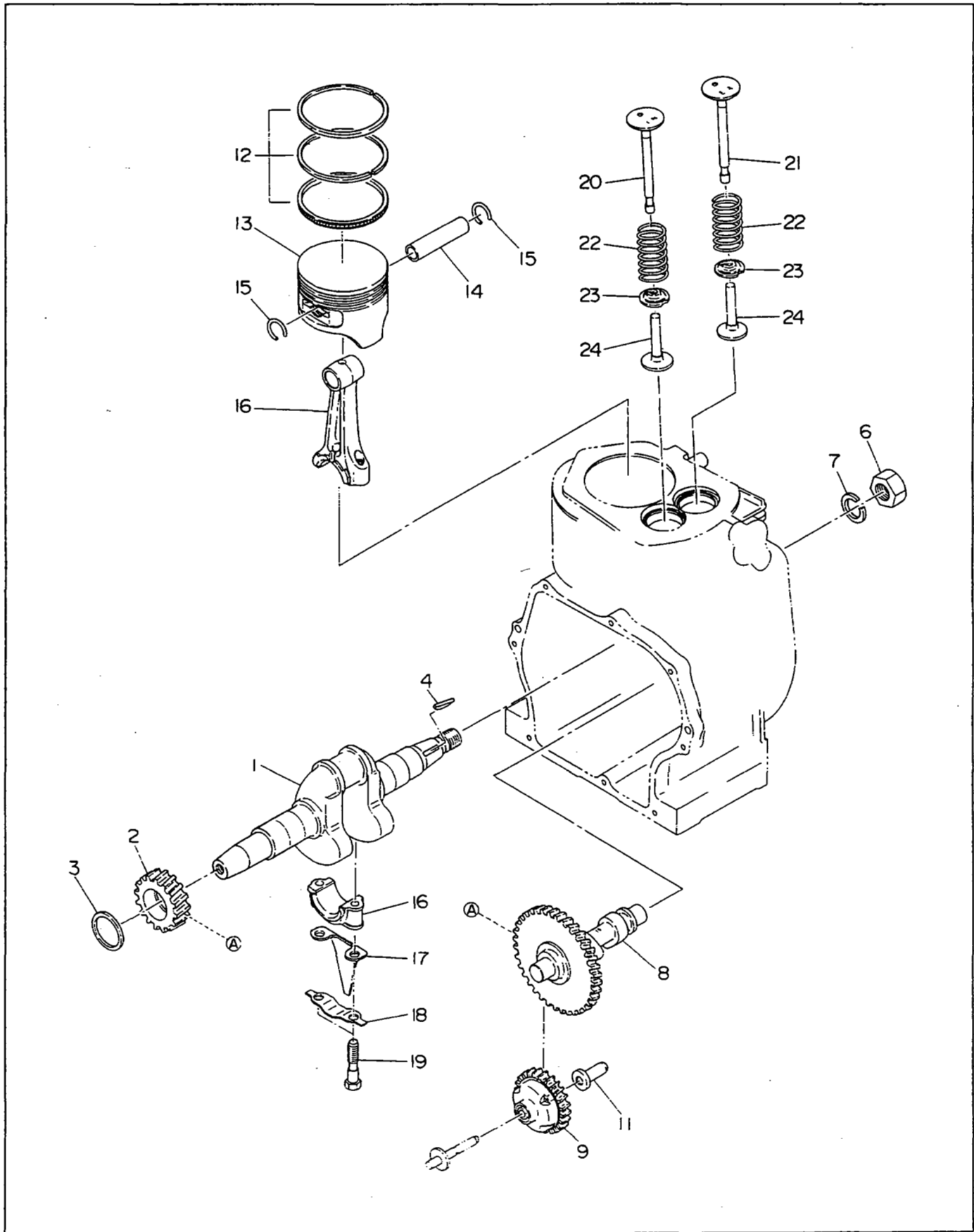

FIG. 7 GOVERNOR

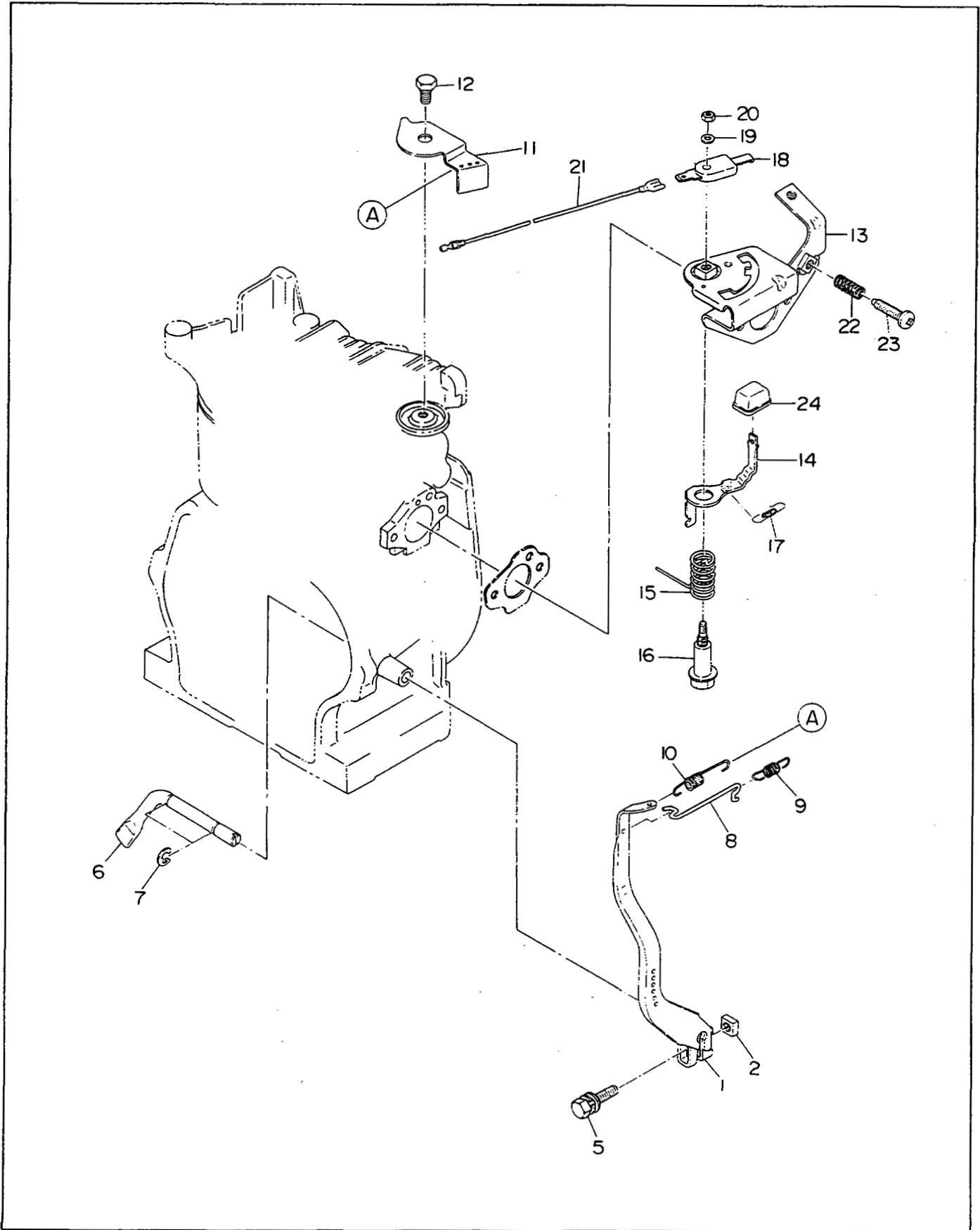

FIG. 8 BLOWER HOUSING and MUFFLER

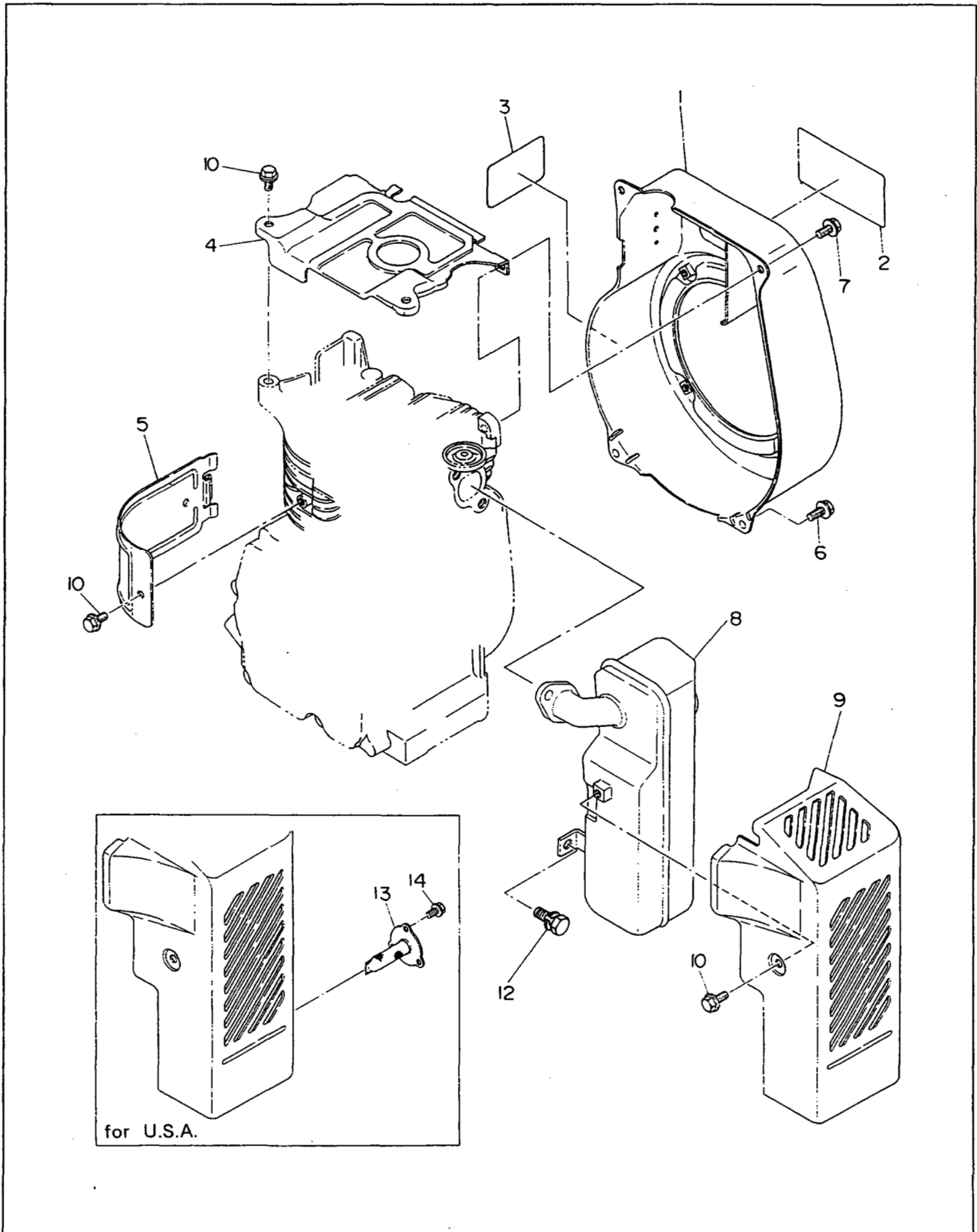

FIG. 9 CARBURETOR and AIR CLEANER

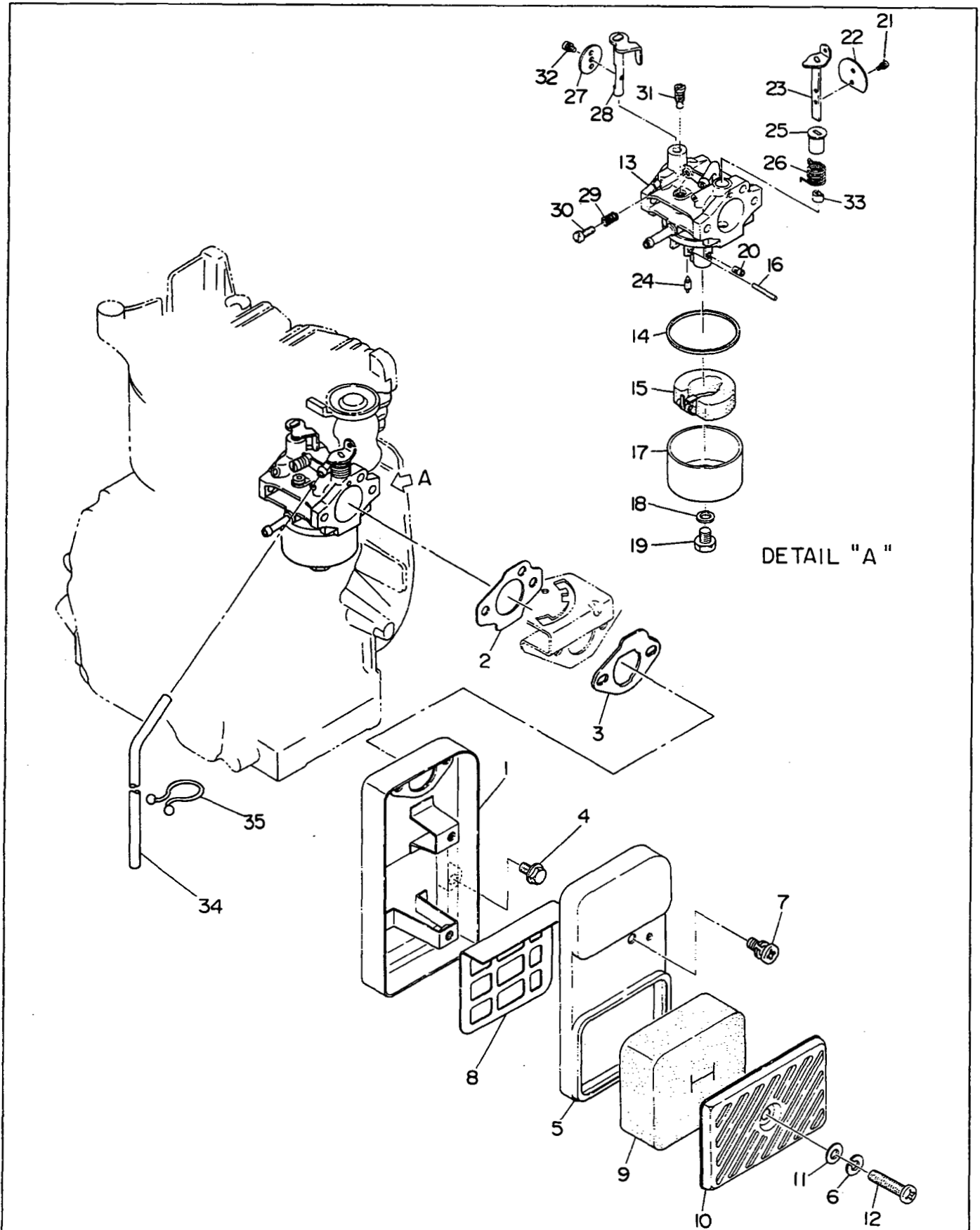

FIG. 10 MAGNETO

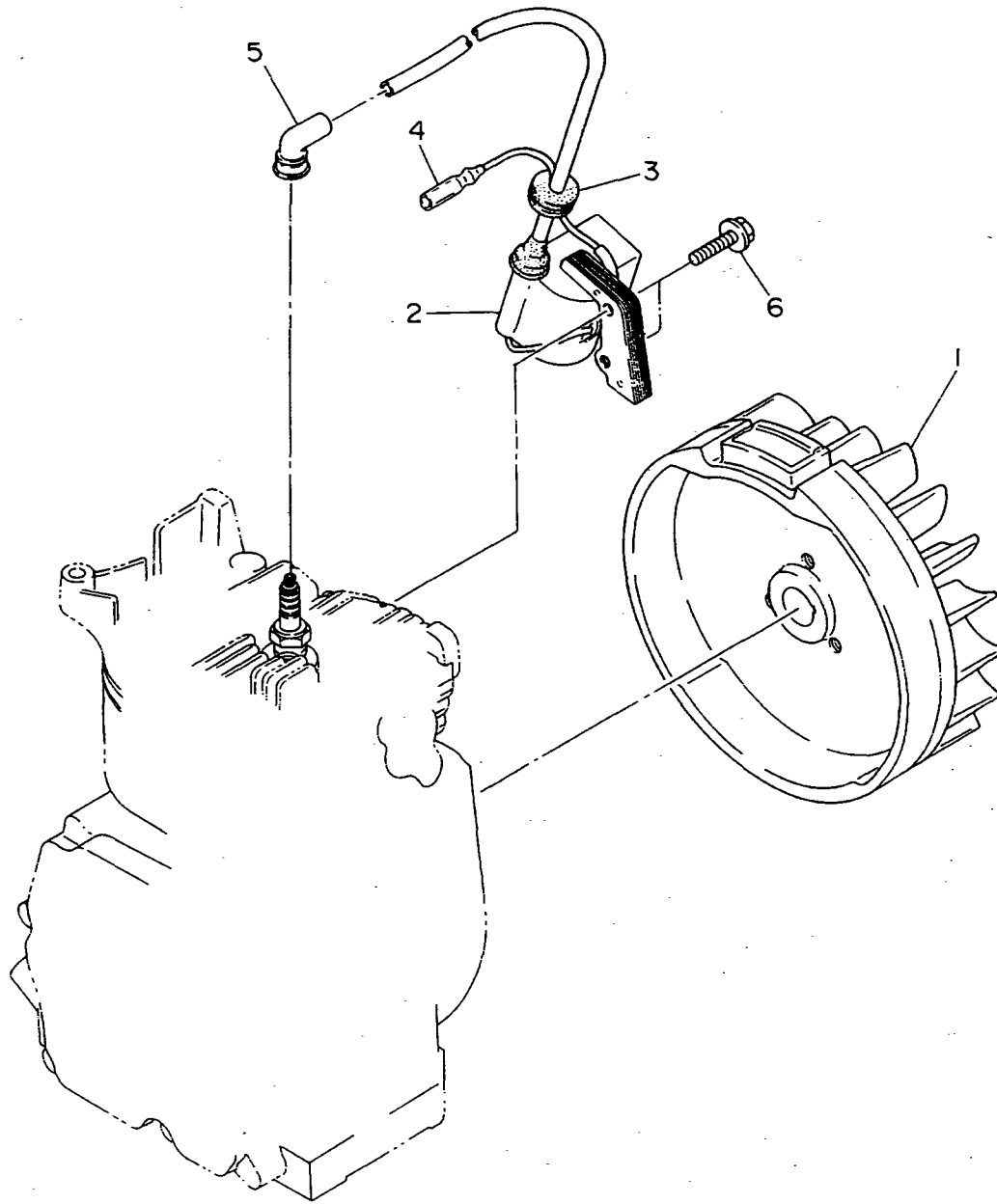
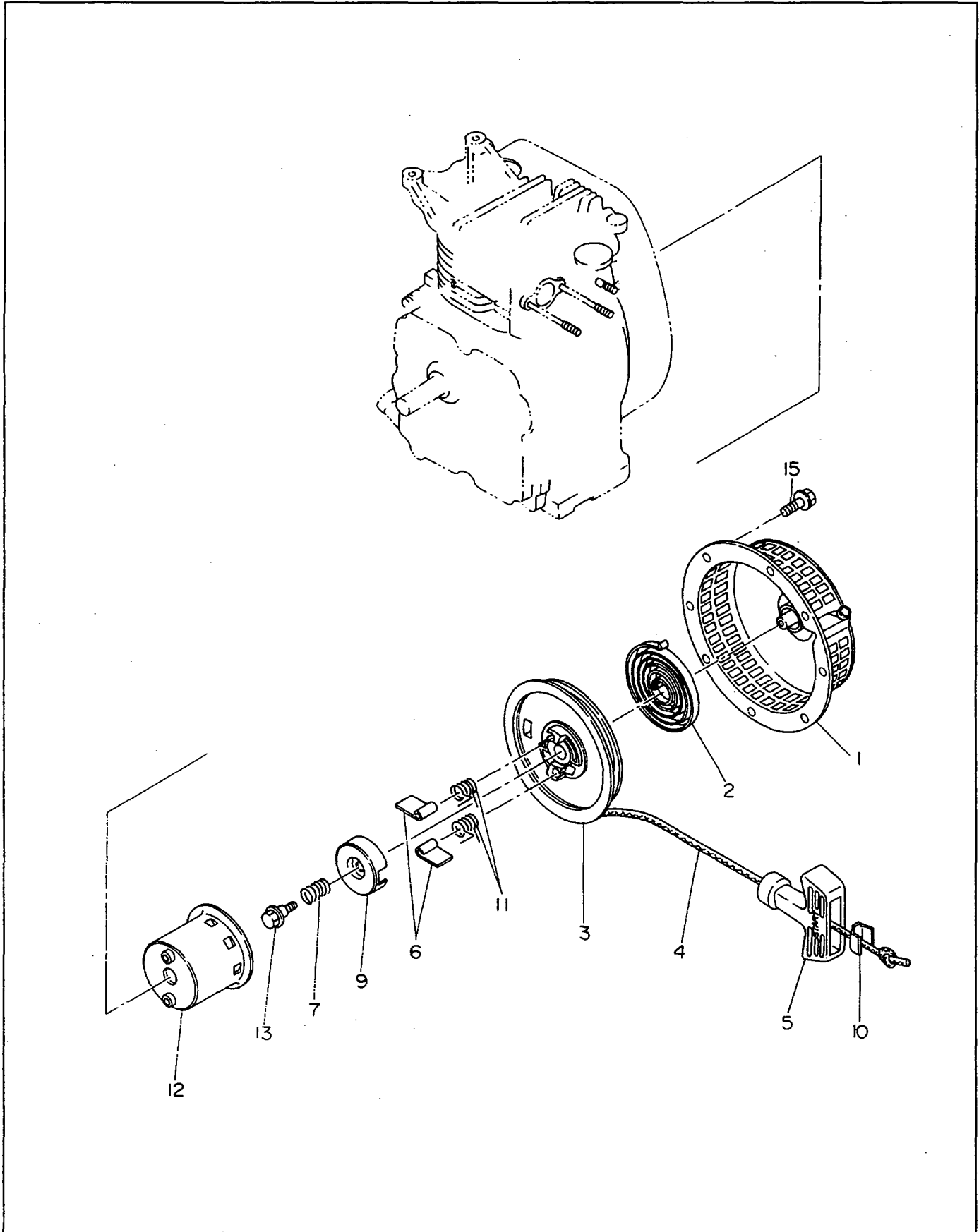

FIG. 11 RECOIL STARTER



Robin America, Inc.

940 Lively Blvd. • Wood Dale, IL 60191 • Phone: 630-350-8200 • Fax: 630-350-8212
e-mail: sales@robinamerica.com • www.robinamerica.com

PRINTED IN THE USA

Robin America, Inc.

