

# Hamilton Beach®

## *Stand Mixer*

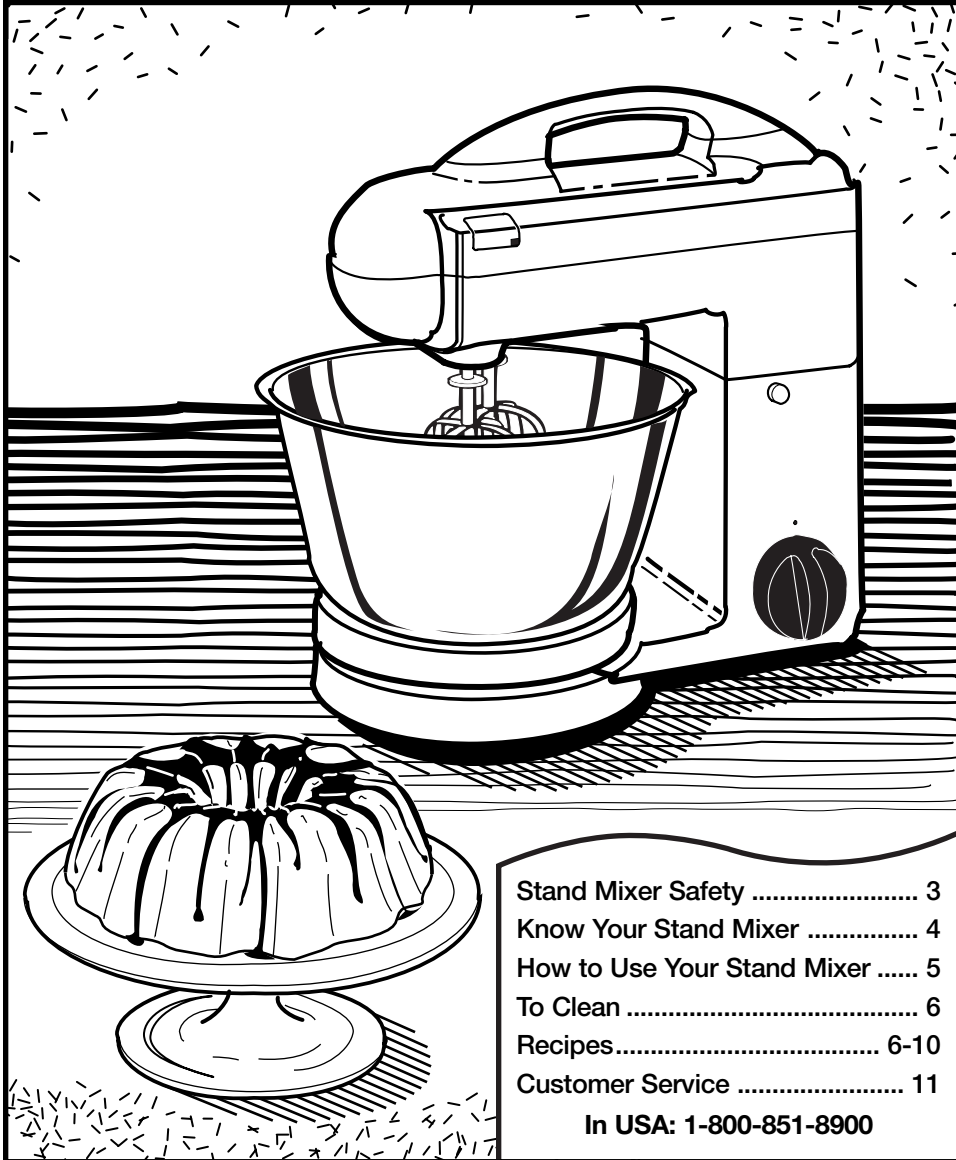

Stand Mixer Safety .....	3
Know Your Stand Mixer .....	4
How to Use Your Stand Mixer .....	5
To Clean .....	6
Recipes.....	6-10
Customer Service .....	11

**In USA: 1-800-851-8900**

840082000

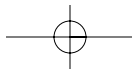
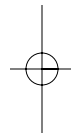
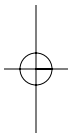

# Stand Mixer Safety

## IMPORTANT SAFEGUARDS

When using electric appliances, basic safety precautions should always be followed, including the following:

1. Read all instructions.
2. To protect against risk of electrical shock, do not put cord, plug, or Mixer body in water or other liquid.
3. Close supervision is necessary when any appliance is used by or near children.
4. Unplug from outlet when not in use, before putting on or taking off parts, and before cleaning.
5. Remove beaters and other attachments from Mixer before washing.
6. Do not operate any appliance with a damaged cord or plug or after the appliance malfunctions or is dropped or damaged in any manner. Call our toll-free customer service number for information on examination, repair, or electrical or mechanical adjustment.
7. The use of attachments not recommended or sold by Hamilton Beach/Proctor-Silex, Inc. for use with this model may cause fire, electric shock or injury.
8. Avoid contacting moving parts. Keep hands, hair, and clothing, as well as spatulas and other utensils, away from beaters during operation to reduce risk of injury to persons, and/or damage to Mixer.
9. Do not use outdoors.
10. Do not let cord hang over edge of table or counter. Do not let cord contact hot surfaces, including stove.
11. Do not place on or near a hot gas or electric burner, or in a heated oven.
12. Check that control is off before plugging cord into wall outlet. To disconnect, turn control to OFF, then remove plug from wall outlet.
13. Do not use appliance for other than intended purpose.

## SAVE THESE INSTRUCTIONS

### Consumer Safety Information

This appliance is intended for household use only.

This appliance is equipped with a polarized plug. This type of plug has one blade wider than the other. The plug will fit into an electrical outlet only one way. This is a safety feature intended to help reduce the risk of electrical shock. If you are unable to insert the plug into the outlet, try reversing the plug. If the plug should still fail to fit, contact a qualified electrician to replace the obsolete outlet. Do not attempt to defeat the safety purpose of the polarized plug by modifying the plug in any way.

The length of the cord used on this appliance was selected to reduce the hazards of becoming tangled in, or tripping over a longer cord. If a longer cord is necessary an approved extension cord may be used. The electrical rating of the extension cord must be equal to or greater than the rating of the stand mixer. Care must be taken to arrange the extension cord so that it will not drape over the countertop or tabletop where it can be pulled on by children or accidentally tripped over.

# Know Your Stand Mixer

## Parts and Features

### 1. Mixer Head

### 2. Beater Eject Button

This button allows finger-tip release of all attachments. Fully depress button to eject attachments.

### 3. Mixer Release Button

This button locks the Mixer Head down to ensure thorough mixing. When the Mixer Head is raised it also locks it in the upright position. Hold the Mixer Head when lowering it into the bowl.

Do not press the Mixer Release Button and let Mixer Head fall into bowl.

### 4. Sensor Speed™ Control

### 5. 2-Position Turntable

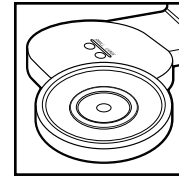

The turntable places large or small bowls close to the attachments to minimize having to scrape the sides of the bowls. It is important to have the turntable in proper position to ensure thorough mixing, kneading, and whisking.

### 6. Cord Storage

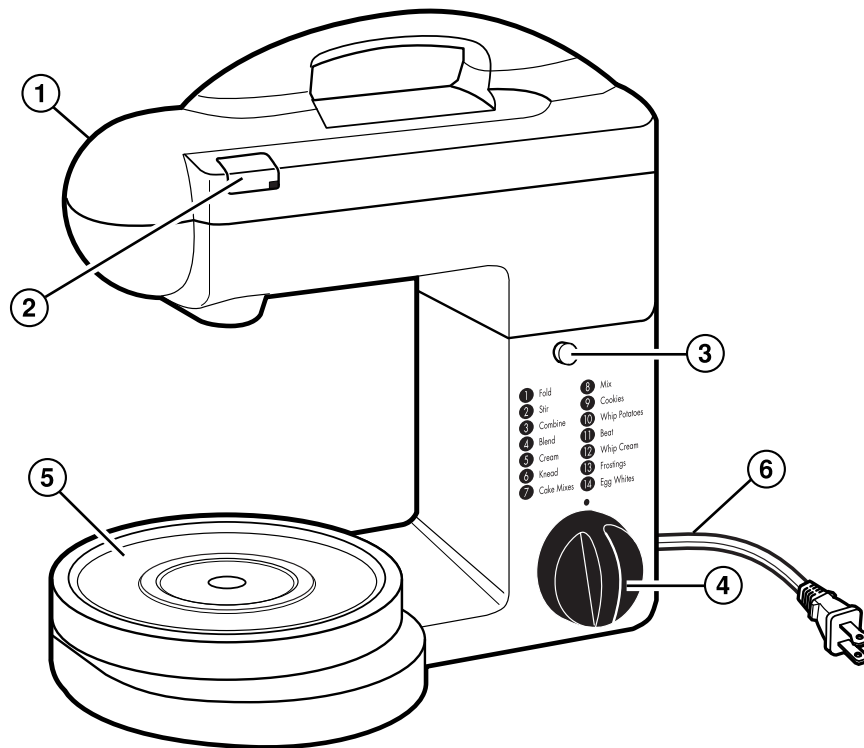

## How to Insert Attachments

Each set of attachments must be inserted into the proper hole in the Mixer Head. They are not interchangeable; there is a right and a left. Beneath the collar is etched a small R or L. This indicates the correct hole to place attachment. The "RIGHT" side of the Mixer is the side with the Sensor Speed control. The beater marked R, with

the flat bottom, should be placed in the hole on the right side of the Mixer first. Insert attachment into hole and turn slowly until tabs slip into slots in hole. Push in until attachment locks in place. Then insert the beater marked L, with the rounded bottom. If difficult to insert, turn beater one quarter turn and try again.

### Mixer Head Graphics

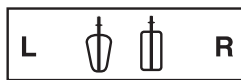

## How To Use Your Stand Mixer

1. Before using, wash bowls and attachments in hot, soapy water. Rinse and dry.
2. Make sure the Mixer is turned to OFF and unplugged.
3. Place small post on bottom of Turntable in hole on Mixer Base that matches bowl to be used.
4. Press the Mixer Release button and raise the Mixer Head up.
5. The beaters and dough hooks must be inserted into specific holes in the Mixer Head. See "How to Insert Attachments."
6. Place bowl onto Turntable. To lower Mixer Head, first raise Mixer Head slightly and press Mixer Release button to release. Lower into bowl. When lowered, the Mixer Head automatically locks into place.
7. Plug cord into electrical outlet. Select desired speed. Prepare recipe according to instructions.
8. When finished, turn Sensor Speed Control to OFF. Unplug from outlet.
9. Press Mixer Head release button, raise Mixer Head until locked into place.
10. Press Beater Eject Button to remove attachments.

## Sensor Speed™ Guide

This is an illustration of the Sensor Speed Guide on your Mixer. The guide may help you select a speed for most mixing tasks. These guides are recommendations. Please adjust Mixer speed as needed.

1 Fold	8 Mix
2 Stir	9 Cookies
3 Combine	10 Whip Potatoes
4 Blend	11 Beat
5 Cream	12 Whip Cream
6 Knead	13 Frostings
7 Cake Mixes	14 Egg Whites

## Notes About Your Stand Mixer

- The Mixer Head locks down for thorough mixing. However, there will be some “bouncing” of the Mixer Head during heavy mixing or kneading. This is caused by the flexibility designed into the Mixer.
- If a spoon is accidentally caught in attachments or the motor stalls, the Mixer will automatically shut off. If this happens, turn Mixer off, then unplug. Clear obstruction. Let motor cool for 5 minutes before continuing.
- Always stay near Mixer during use. The speed of turning bowls should always be monitored.

### *Hints!*

Follow these helpful hints when mixing thin batters:

- Use medium speeds.
- Bowl may not automatically rotate. Simply rotate bowl by hand.
- Scrape sides of bowl with spatula frequently.
- When whipping cream, eggs or liquids, use the smaller bowl and higher speeds.

## To Clean

1. Make sure Sensor Speed Control is turned to OFF and Mixer is unplugged.
2. Raise Mixer Head to up locked position.
3. Press Beater Eject Button to eject attachments.
4. Bowls, beaters, and dough hooks may be washed in hot, soapy water or in automatic dishwasher.
5. Wipe Head, Base, and Turntable of Mixer with a damp cloth.

## Recipes

Check our Web site at [www.hamiltonbeach.com](http://www.hamiltonbeach.com) for more recipes.

### A Few Words About Baking Bread...

All of our recipes were tested using all-purpose flour. Bread flour can also be used.

Most of these recipes call for shaping bread into a loaf and baking in a loaf pan. However, bread can be shaped into any shape and baked in almost any pan. The only thing this affects is the baking time.

All of the yeast bread recipes were made using the dough hooks on **Knead (6)**.

### *Bread Tips!*

- When yeast is dissolved in warm water, the water temperature should be 105° to 115°F. This is usually very warm tap water.
- Bread rises best in a moist, warm environment. For a perfect place to raise bread, place bread in a microwave oven or regular oven with a pan of steaming water. Do not turn oven on, but close the door.

## Basic White Bread

---

2 packages active dry yeast	3 tablespoons sugar
2½ cups warm water	2 teaspoons salt
3 tablespoons butter or margarine, melted	6 to 7 cups all-purpose flour

Using dough hooks, in large mixing bowl combine yeast and ½ cup of warm water. **Knead (6)** until dissolved. Add remaining warm water, butter, sugar, and salt. Add 6 cups of flour and **Knead (6)** until blended. Add enough of remaining flour and continue to knead until dough forms a smooth ball that is slightly sticky to the touch. Place dough in large, greased bowl. Cover and let rise until double in size, about 1 hour. Punch dough down, divide in half, and shape into loaves. Place loaves into two 9x5-inch greased loaf pans and let rise until double in size, about 1 hour. Bake at 350°F for 40 minutes.

## 100% Whole Wheat Bread

---

2 packages active dry yeast	1 teaspoon salt
2 cups warm water	1 egg
⅓ cup vegetable oil	6 to 7 cups whole wheat flour
⅓ cup honey	

In a large bowl, sprinkle yeast over water and let stand 5 to 10 minutes or until foamy. Stir to mix, then add oil, honey, salt, and egg. Add 3 cups of the flour and, using dough hooks, **Knead (6)** for about 1 minute. Let stand about 20 minutes until bubbly and starting to rise. Add 3 more cups flour and **Knead (6)** until mixed. Add enough of remaining flour and **Knead (6)** until dough forms a smooth ball that is slightly sticky to the touch. Place dough in large, greased bowl. Cover and let rise 30 minutes or until double. Punch down and let rise 1 hour. Punch down. Divide into two pieces and shape into loaves. Let rise 30 minutes or until double. Bake at 400°F for 25 minutes.

## Honey Wheat Bread

---

2 packages active dry yeast	¼ cup honey
½ cup warm water	2 teaspoons salt
1¾ cups milk	3 cups whole wheat flour
¼ cup butter or margarine, melted	2 to 3 cups all-purpose flour

In a large mixing bowl, combine yeast and water. Stir until dissolved. Add milk, butter, honey, and salt. Stir until mixed. Add whole wheat flour and 2 cups of all-purpose flour and, using dough hooks, **Knead (6)** until blended. Add enough of remaining flour, and continue kneading, until dough forms a smooth ball that is slightly sticky to the touch. Place dough in large greased bowl and cover with a towel. Let rise until double in size, about an hour. Punch dough down, divide in half, and shape into loaves. Place loaves into 2 9x5-inch greased loaf pans and let rise until double in size, about 1 hour. Bake at 350°F about 35 minutes.

## Dinner Pan Rolls

½ cup warm water	¼ cup sugar
1 package active dry yeast	1 egg
½ cup warm milk	1½ teaspoon salt
¼ cup vegetable oil	3½ to 4 cups all-purpose flour

In large mixing bowl, dissolve yeast in warm water. Add milk, oil, sugar, egg, salt, and 2 cups flour. Using dough hooks, **Knead (6)** until blended. Add 1 more cup flour and **Knead (6)**. Add remaining flour as needed until a ball of dough forms and is slightly sticky to the touch. Place dough in greased bowl and cover with a towel. Let rise 45 minutes. Punch dough down and pat into a greased 9x13-inch pan. Using a sharp knife, cut almost through dough into squares. Brush cuts with melted butter. Let rise until double in size, about 1 hour. Bake at 400°F for 20 to 25 minutes.

## Onion Herb Bread

2 packages active dry yeast	3 tablespoons sugar
½ cup warm water	1 teaspoon salt
2 tablespoons vegetable oil	½ teaspoon dried dill
½ cup finely chopped onion	¼ teaspoon ground sage
1½ cups milk	¾ cup yellow cornmeal
2 tablespoons dried parsley flakes	4 cups whole wheat flour

In a small bowl, dissolve yeast in water. In a small pan, saute onion in oil until tender. In large mixing bowl, combine onion, milk, parsley, sugar, salt, dill, sage, and dissolved yeast. Stir to mix. Add cornmeal and 3 cups of the flour. Using dough hooks, **Knead (6)** until mixed. Add enough of remaining flour until dough forms a smooth ball that is slightly sticky to the touch. Place dough in large, greased bowl. Cover and let rise until double in size. Punch down dough then divide in half. Shape into 2 loaves. Cover and let rise about 40 minutes or until double in size. Bake at 350°F for 45 minutes.

## Bran Raisin Muffins

½ cup vegetable shortening	1 teaspoon salt
½ cup sugar	2 cups buttermilk
½ cup dark brown sugar	(or see substitute below)
2 eggs	5 cups bran flakes
2½ cups all-purpose flour	1 cup raisins
2½ teaspoons baking soda	

(To make a substitute for 2 cups buttermilk, put 2 tablespoons lemon juice or vinegar in a 2 cup measure. Fill to 2 cups with milk.)

In a large bowl, using beaters, **Cream (5)** together shortening and sugars. Add eggs and blend. Stir together flour, baking soda, and salt. Alternately add flour mixture and buttermilk to mixture in mixing bowl then **Mix (8)**. Reduce to **Fold (1)** and add bran flakes and raisins. Spoon into greased muffin pans. Bake at 400°F for 20 minutes. Yield: 2 dozen.



## Mashed Potatoes

1½ pounds all-purpose white potatoes	1 tablespoon butter or margarine, room temperature
5-ounce can evaporated fat-free milk	¼ teaspoon salt
	¼ teaspoon pepper

Wash potatoes and peel if desired. Cut into pieces the size of golf balls. Place in saucepan and cover with water. Bring to a boil and let cook 15 to 20 minutes or until fork tender. Drain. Heat the evaporated milk. In mixing bowl, place potatoes, heated milk, butter, salt and pepper. Using beaters, **Mix (8)** until combined then increase to **Whip Potatoes (10)** until smooth.

## White Chocolate Cheesecake

6 ounces white chocolate, chopped	3 8-ounce packages cream cheese, room temperature
2 cups vanilla wafer crumbs	4 eggs
¼ cup butter or margarine, melted	1 teaspoon vanilla extract
1 tablespoon all-purpose flour	
¾ cup sugar	

In top of a double boiler, over simmering water, melt white chocolate. Set aside and cool slightly.

In a small bowl, combine vanilla wafer crumbs and butter. Press onto bottom and up sides of 9-inch springform pan. Stir flour into sugar. In a large mixing bowl, using beaters, **Beat (11)** cream cheese. Add sugar/flour mixture and **Blend (4)** until smooth. Add eggs, one at a time, and **Beat (11)** until smooth. Add vanilla and melted chocolate and **Mix (8)**. Pour into prepared pan. Bake in preheated 350°F oven for 45 to 50 minutes or until edges are set. Center will be shaky. Cool then refrigerate at least 4 hours before serving. May be prepared 1 to 2 days in advance.

## Dark Chocolate Walnut Cake

<b>Cake:</b>	<b>Glaze:</b>
8 ounces semi-sweet baking chocolate	3 ounces semi-sweet baking chocolate
5 eggs, separated	¼ cup milk
1 cup (2 sticks) butter or margarine	
1 cup sugar	
2 tablespoons flour	
3 tablespoons unsweetened baking cocoa	
1 cup finely ground walnuts	

In the top of a double boiler, over simmering water, melt chocolate. Set aside and cool slightly.

Using beaters, beat the egg whites in a small mixing bowl on **Egg Whites (14)** until stiff but not dry. Set aside. In large mixing bowl **Cream (5)** butter and sugar until fluffy. Add egg yolks, one at a time. Reduce speed to **Blend (4)**. Combine flour and cocoa, then add flour mixture to butter/egg mixture and mix until blended. Add melted chocolate and nuts. Reduce to **Fold (1)** and add half of beaten egg whites. Fold in remaining egg whites by hand. Pour mixture into greased and floured tube or bundt pan. Bake at 350°F for 50 minutes. The cake will not rise to the top of the pan. A crust will form on the top but the center will be moist. Cool in pan 10 minutes then turn out onto cooling rack. The cake will fall. Let cool completely then drizzle with glaze.

**To make glaze**, combine chocolate and milk in a small saucepan over low heat. Stir occasionally until melted, then spoon over top of cake, letting glaze drip down sides.

## Sour Cream Pound Cake

1 cup (2 sticks) butter or margarine	3 cups all-purpose flour
½ cup vegetable	1 8-ounce container sour cream
2½ cups sugar	2 teaspoons vanilla
5 eggs	

In a large mixing bowl, using beaters **Cream (5)** butter, shortening, and sugar. Add eggs. Reduce speed to **Blend (4)** then add flour, sour cream, and vanilla. Mix until well blended. Spoon into greased and floured tube or bundt pan. Bake at 325°F for 1½ hours or until the cake tests down with a toothpick.

## Ginger Cookie Bars

¾ cup vegetable shortening	2 teaspoons baking soda
1 cup sugar	1 teaspoon ground cinnamon
¼ cup molasses	½ teaspoon ground cloves
1 egg	½ teaspoon ground ginger
½ teaspoon vanilla	½ teaspoon salt
2 cups flour	

In a mixing bowl, using beaters combine shortening, sugar, molasses, egg, and vanilla. **Cream (5)** until smooth. Add flour, baking soda, cinnamon, cloves, ginger, and salt. **Stir (2)** until blended. Spread in an ungreased 15x10x1-inch baking pan. Bake at 375°F for 12 minutes or until lightly browned. Do not overbake. Cool on a wire rack before cutting. Makes about 4 dozen bars.

## Brown Sugar Butterscotch Cookies

1 cup butter, room temperature	½ teaspoon salt
1 cup white sugar	1 teaspoon baking soda
1 cup brown sugar	4 cups crispy rice cereal
2 eggs	2 cups butterscotch chips
2 teaspoon vanilla	
2½ cups flour	

In a large mixing bowl, using beaters **Cream (5)** butter and sugars. Add eggs and vanilla and continue mixing. Add flour, salt, and baking soda and **Mix (8)** until just mixed. Add rice cereal and chips and mix on speed 8 until mixed. Drop by spoonfuls onto cookie sheet. Bake at 350°F for 12 to 15 minutes or until lightly browned. Makes 6 dozen.

# Customer Service

If you have a question about your stand mixer, call our toll-free customer service number. Before calling, please note the model, type, and series numbers and fill in that information below. These numbers can be found on the bottom of your stand mixer. This information will help us answer your question much more quickly.

**MODEL:** \_\_\_\_\_ **TYPE:** \_\_\_\_\_ **SERIES:** \_\_\_\_\_

## LIMITED WARRANTY

This product is warranted to be free from defects in material and workmanship for a period of two (2) years for Hamilton Beach Portfolio products or one (1) year for Hamilton Beach products from the date of original purchase, except as noted below. During this period, we will repair or replace this product, at our option, at no cost. THE FOREGOING WARRANTY IS IN LIEU OF ANY OTHER WARRANTY, WHETHER EXPRESS OR IMPLIED, WRITTEN OR ORAL INCLUDING ANY WARRANTY OF MERCHANTABILITY OR FITNESS FOR A PARTICULAR PURPOSE. ANY LIABILITY IS EXPRESSLY LIMITED TO AN AMOUNT EQUAL TO THE PURCHASE PRICE PAID, AND ALL CLAIMS FOR SPECIAL, INCIDENTAL AND CONSEQUENTIAL DAMAGES ARE HEREBY EXCLUDED. There is no warranty with respect to the following, which may be supplied with this product: glass parts, glass containers, cutter/strainer, blades, and/or agitators. This warranty extends only to the original consumer purchaser and does not cover a defect resulting from abuse, misuse, neglect, use for commercial purposes, or any use not in conformity with the printed directions. This warranty gives you specific legal rights, and you may also have other legal rights which vary from state to state, or province to province. Some states or provinces do not allow limitations on implied warranties or special, incidental or consequential damages, so the foregoing limitations may not apply to you.

If you have a claim under this warranty, DO NOT RETURN THE APPLIANCE TO THE STORE! Please call our CUSTOMER SERVICE NUMBER. (For faster service please have model, series, and type numbers ready for operator to assist you.)

## CUSTOMER SERVICE NUMBERS

In the U.S. 1-800-851-8900

In Canada 1-800-267-2826

Web site address: [www.hamiltonbeach.com](http://www.hamiltonbeach.com)

**KEEP THESE NUMBERS FOR FUTURE REFERENCE!**

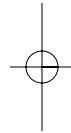
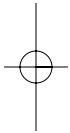

HAMILTON BEACH  PROCTOR-SILEX, INC.  
263 Yadkin Road  
Southern Pines, North Carolina 28387

PROCTOR-SILEX CANADA, INC.  
Picton, Ontario K0K 2T0

Web site address: [www.hamiltonbeach.com](http://www.hamiltonbeach.com)

