

Hoshizaki America, Inc.

Modular Crescent Cuber

Models

KML-250MAH

KML-250MWH



“A Superior Degree
of Reliability”

www.hoshizaki.com

PARTS LIST



Number: 71192
Issued: 9-18-2001
Revised: 12-29-2009

CONTENTS

Auxiliary Codes.....	3
Note About Ordering Parts	3
Material Abbreviations	4
A. Ice Cuber Assembly	5
KML-250MAH.....	5
KML-250MWH.....	8
B. Refrigeration Circuit	11
KML-250MAH.....	11
KML-250MWH.....	14
C. Water Circuit	17
D. Control Box Assembly.....	21
E. Label Location.....	24
F. Top Panel Assembly	26
G. Front Panel Assembly.....	27
H. Accessories & Packaging	28

Auxiliary Codes

KML-250MAH	L-0	May 2001
	M-0	January 2002
	M-1	April 2002
	M-2	July 2002
	N-0	December 2002
	N-1	March 2003
	P-0	December 2003
	P-1	June 2004
	Q-0	December 2004
	R-0	December 2005
	S-1	January 2007
	S-2	December 2007
	T-0	January 2008
	U-0	January 2009
U-1	July 2009	

KML-250MWH	L-1	October 2001
	M-0	December 2001
	M-1	March 2002
	M-2	July 2002
	N-0	January 2003
	N-1	March 2003
	P-0	December 2003
	Q-0	January 2005
	R-0	January 2006
	S-1	January 2007
	S-2	December 2007
	T-0	January 2008
	U-0	January 2009
	U-1	July 2009

Auxiliary Code Breakdown

The auxiliary code is the first two characters in the serial number. The first character indicates the year. Years progress or regress in alphabetical order. The series runs from "A" through "V" and the letters "I" and "O" are skipped. The second character indicates significant part changes within a year. Base is "0" and this number advances for each change. In cases where there is a letter in parentheses, this designates the month. This is the last character in the serial number. The series runs from "(A)" through "(M)" and the letter "(I)" is skipped. This designation is only included when identifying a parts change within an auxiliary code.

Note About Ordering Parts

Most assemblies cannot be ordered as complete units; parts in the assemblies generally must be ordered separately.

Material Abbreviations

ALUMINUM

AL = Aluminum

COPPER

CU = Copper

PLASTIC

ABS = Acrylonitrile -butadiene -styrene
AC = Polyacetal
EVA = Ethylene vinyl acetate
PA = Polyamide = Nylon
PC = Polycarbonate
PE = Polyethylene
PES = Polyester
PETP = Polyethylene terephthalate = Tetlon
PP = Polypropylene
PS = Polystyrene
PTFE = Polytetrafluoroethylene = Teflon
PUR = Polyurethane
PVC = Polyvinyl chloride

RUBBER

VN = Vinyl Nitrile
EPDM = EP rubber
NBR = Nitrile butadiene rubber
NR = Natural rubber
NP = Neoprene
SI.R = Silicone rubber
SY.R = Synthetic rubber
EPH = Epichlorohydrin

STEEL

GS = Galvanized steel
SS = Stainless steel
PS = Plated steel
PAS = Primed steel

A. Ice Cuber Assembly
KML-250MAH
 L-0 to U-1

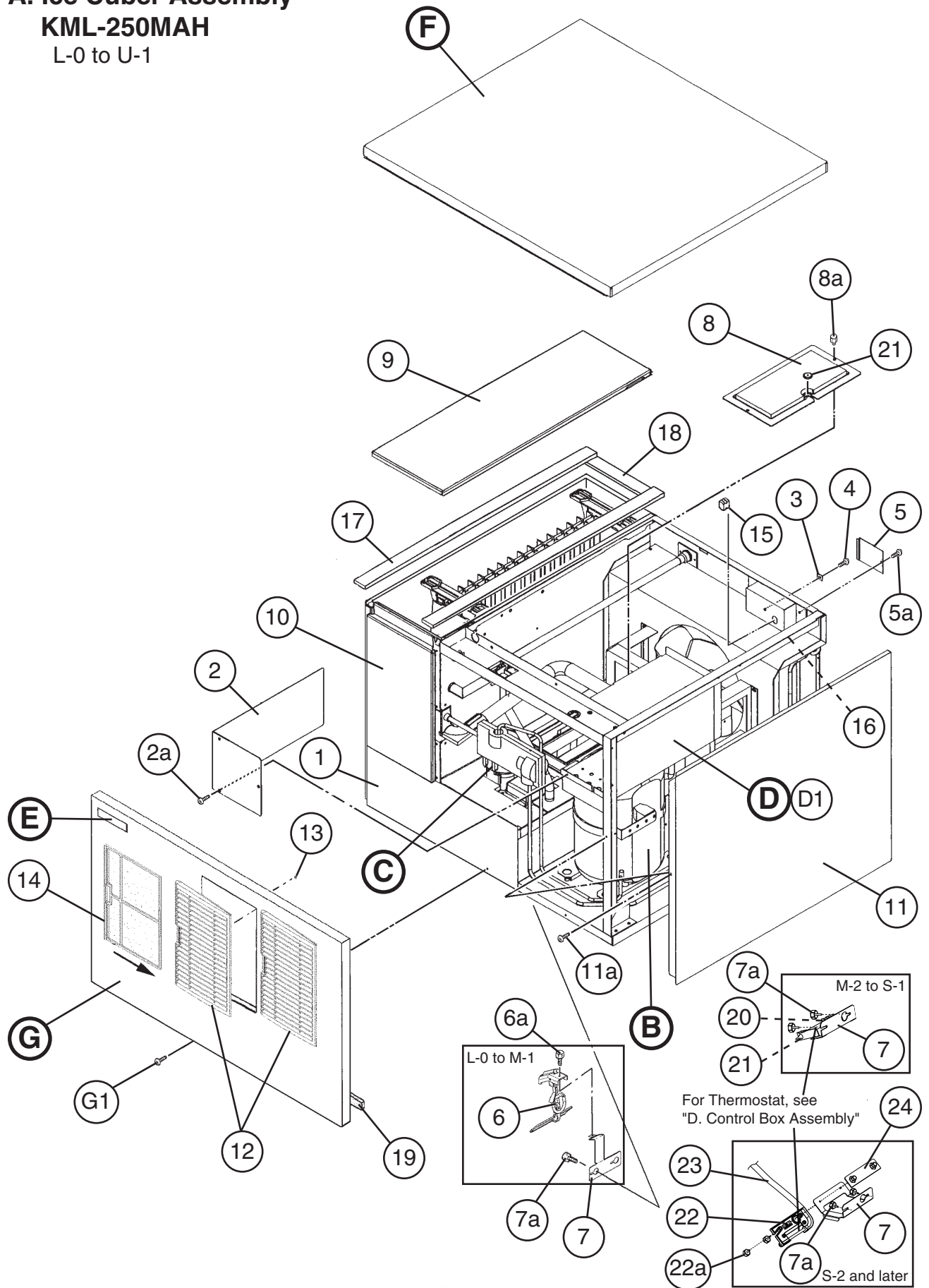

Title: **A. Ice Cuber Assembly** Model: **KML-250MAH**

Index No.	Description	Material or Model Number	Part Number	Required Number									
				L-0 M-0	M-1	M-2 to S-1	S-2 to U-0	U-1					
B	Refrigeration Circuit	-	1A0604A01	1	-								
			1A0604A02		1	1	1	1					
C	Water Circuit	-	1A0438A01	1	1	1	-						
			1A0438A02				1	-					
			1A0438A03						1				
D	Control Box Assembly	-	2A2291A01	1	1	-							
			2A2545A01			1	1	-					
			2A2545A02						1				
D1	T2 Screw	4x8	7P31-0408	3	3	3	3	3					
E	Label Location	-	3A2043A01	1	1	-							
			3A2427A01			1	1	-					
			3A5423A01						1				
F	Top Panel Assembly	-	3A1862A01	1	1	1	1	1					
G	Front Panel Assembly	-	3A1859A01	1	1	1	1	1					
G1	Truss Head Screw	4x8, SS	7C32-0408	1	1	1	1	1					
1	Evaporator Case	-	2A2238G01	1	1	1	1	1					
2	Control Box Cover	GS	3A1828-01	1	1	-							
			3A2371-01			1	1	1					
2a	T2 Screw	4x8	7P31-0408	3	3	3	3	3					
3	Square Washer	Brass	433537-02	1	1	1	1	1					
4	Screw-Grounding	Brass	433304-02	1	1	1	1	1					
5	Junction Box Cover	GS	433410-01	1	1	1	1	1					
5a	T2 Screw	4x8	7P31-0408	1	1	1	1	1					
6	Mechanical Bin Control	-	4A2430-01	1	1	-							
6a	Thumbscrew	SS, ABS	4H3270G01	1	1	-							
7	Bracket (L)	-	3A1433-01	1	1	-							
	Thermostat Extension Bracket	SS	4A1722-01			1	-						
			4A4358-01				1	1					
7a	Thumbscrew	SS, ABS	415949G09	2	2	2	-						
			415949G10				2	-					
			415949G08						2				
8	Bin Control Cover	GS	3A0664G01	1	1	1	1	1					
8a	Thumbscrew	SS, ABS	415949G04	2	2	2	-						
			415949G08					2	2				
9	Top Insulation	PP	215730G01	1	1	1	1	1					
10	Front Insulation	-	2A0664G01	1	1	1	1	1					
11	Side Panel (R)	SS	2A2111G01	1	1	1	1	1					
11a	T2 Screw	4x8, SS	7P32-0408	1	1	1	1	1					
12	Louver	ABS	1A0548-01	2	2	2	2	2					
13	Push Retainer	-	4A2414-01	6	6	6	6	6					
14	Air Filter	ABS	2A2063G01	2	2	2	2	2					
15	Bushing	SR-30-1	420472-03	1	1	1	1	1					
16	Wire Saddle	VWS4238-C	4A0338-02	2	2	2	2	2					
17	Gasket	L=655	4A0808L02	2	2	2	2	2					
18	Gasket	L=190	4A0808L02	1	1	1	1	1					
19	Gasket	L=762	4A0808L02	1	1	1	1	1					

Title: A. Ice Cuber Assembly Model: KML-250MAH												
Index No.	Description	Material or Model Number	Part Number	Required Number								
				L-0 M-0	M-1	M-2 to S-1	S-2 to U-0	U-1				
20	Spacer	PE	443545-01			1	-					
21	Capillary Ring	EP Rubber	425307-01			2	1	1				
22	Bulb Holder	-	3A3903-01				1	1				
22a	Thumbscrew	SS, ABS	415949G11				2	-				
			415949G10					2				
23	Silicone Hose	L=310	773013812				1	1				
24	NSF Plate	-	4A4401G01				1	1				

A. Ice Cuber Assembly
KML-250MWH
 L-1 to U-1

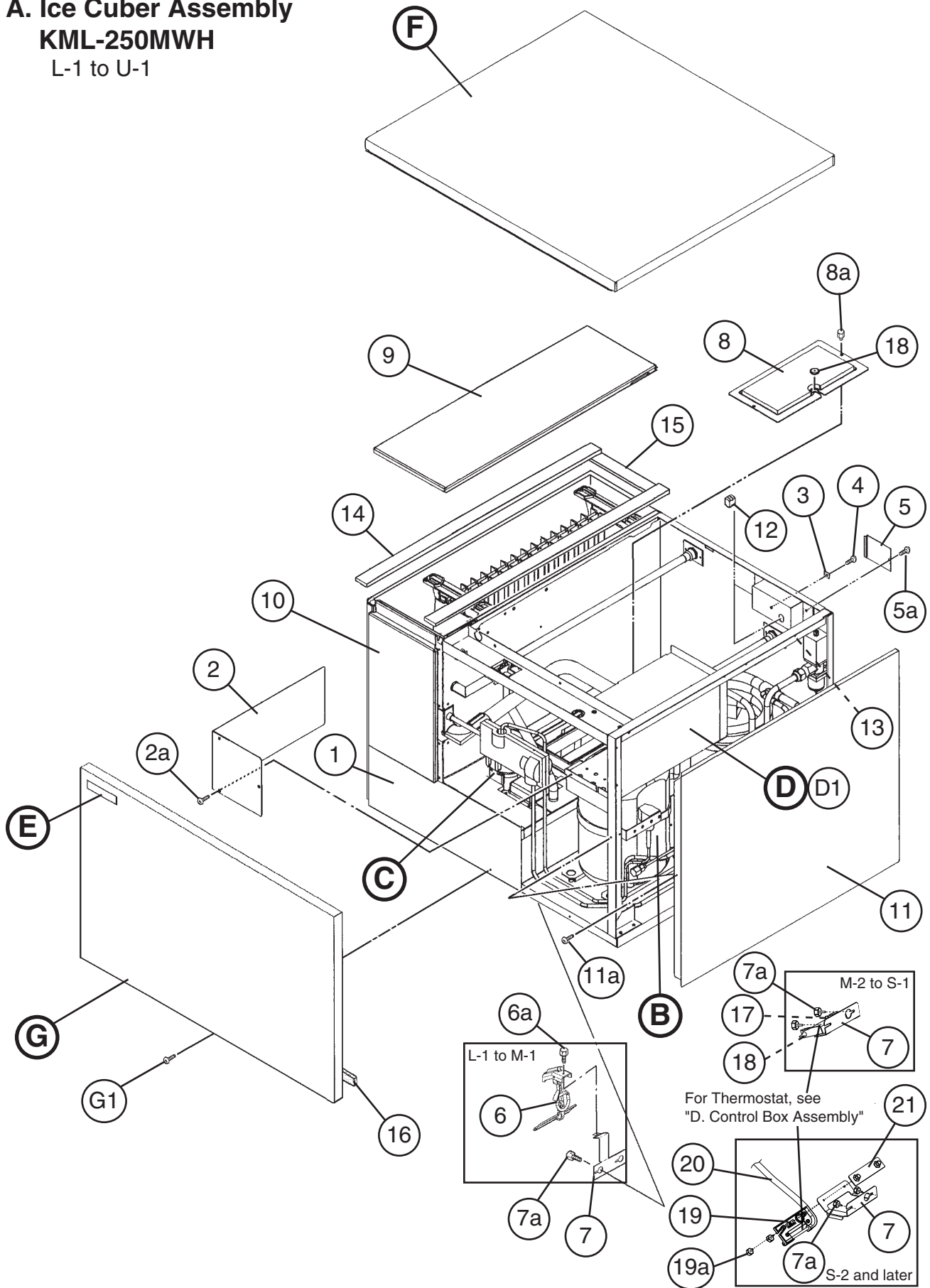

Title: **A. Ice Cuber Assembly** Model: **KML-250MWH**

Index No.	Description	Material or Model Number	Part Number	Required Number													
				L-1 M-0	M-1	M-2 to S-1	S-2 to U-0	U-1									
B	Refrigeration Circuit	-	1A0634A01	1	-												
			1A0634A02		1	1	1	1	1								
C	Water Circuit	-	1A0438A01	1	1	1	-										
			1A0438A02				1	-									
			1A0438A03						1								
D	Control Box Assembly	-	2A2291A01	1	1	-											
			2A2545A01			1	1	-									
			2A2545A02							1							
D1	T2 Screw	4x8	7P31-0408	3	3	3	3	3									
E	Label Location	-	3A1988A01	1	1	-											
			3A2428A01			1	1	-									
			3A5424A01							1							
F	Top Panel Assembly	-	3A1862A01	1	1	1	1	1									
G	Front Panel Assembly	-	3A1859A02	1	1	1	1	1									
G1	Truss Head Screw	4x8, SS	7C32-0408	1	1	1	1	1									
1	Evaporator Case	-	2A2238G01	1	1	1	1	1									
2	Control Box Cover	GS	3A1828-01	1	1	-											
			3A2371-01			1	1	1									
2a	T2 Screw	4x8	7P31-0408	3	3	3	3	3									
3	Square Washer	Brass	433537-02	1	1	1	1	1									
4	Screw-Grounding	Brass	433304-02	1	1	1	1	1									
5	Junction Box Cover	GS	433410-01	1	1	1	1	1									
5a	T2 Screw	4x8	7P31-0408	1	1	1	1	1									
6	Mechanical Bin Control	-	4A2430-01	1	1	-											
6a	Thumbscrew	SS, ABS	4H3270G01	1	1	-											
7	Bracket (L)	-	3A1433-01	1	1	-											
	Thermostat Extension Bracket	SS	4A1722-01			1	-										
			4A4358-01					1	1								
7a	Thumbscrew	SS, ABS	415949G09	2	2	2	-										
			415949G10				2	-									
			415949G08						2								
8	Bin Control Cover	GS	3A0664G01	1	1	1	1	1									
8a	Thumbscrew	SS, ABS	415949G04	2	2	2	-										
			415949G08					2	2								
9	Top Insulation	PP	215730G01	1	1	1	1	1									
10	Front Insulation	-	2A0664G01	1	1	1	1	1									
11	Side Panel (R)	SS	2A2111G01	1	1	1	1	1									
11a	T2 Screw	4x8, SS	7P32-0408	1	1	1	1	1									
12	Bushing	SR-30-1	420472-03	1	1	1	1	1									
13	Wire Saddle	VWS4238-C	4A0338-02	2	2	2	2	2									
14	Gasket	L=655	4A0808L02	2	2	2	2	2									
15	Gasket	L=190	4A0808L02	1	1	1	1	1									
16	Gasket	L=762	4A0808L02	1	1	1	1	1									
17	Spacer	PE	443545-01			1	-										
18	Capillary Ring	EP Rubber	425307-01			2	1	1									

Title: **A. Ice Cuber Assembly** Model: **KML-250MWH**

Index No.	Description	Material or Model Number	Part Number	Required Number									
				L-1 M-0	M-1	M-2 to S-1	S-2 to U-0	U-1					
19	Bulb Holder	-	3A3903-01				1	1					
19a	Thumbscrew	SS, ABS	415949G11				2	-					
			415949G10					2					
20	Silicone Hose	L=310	773013812				1	1					
21	NSF Plate	-	4A4401G01				1	1					

B. Refrigeration Circuit
KML-250MAH
 L-1 to U-1

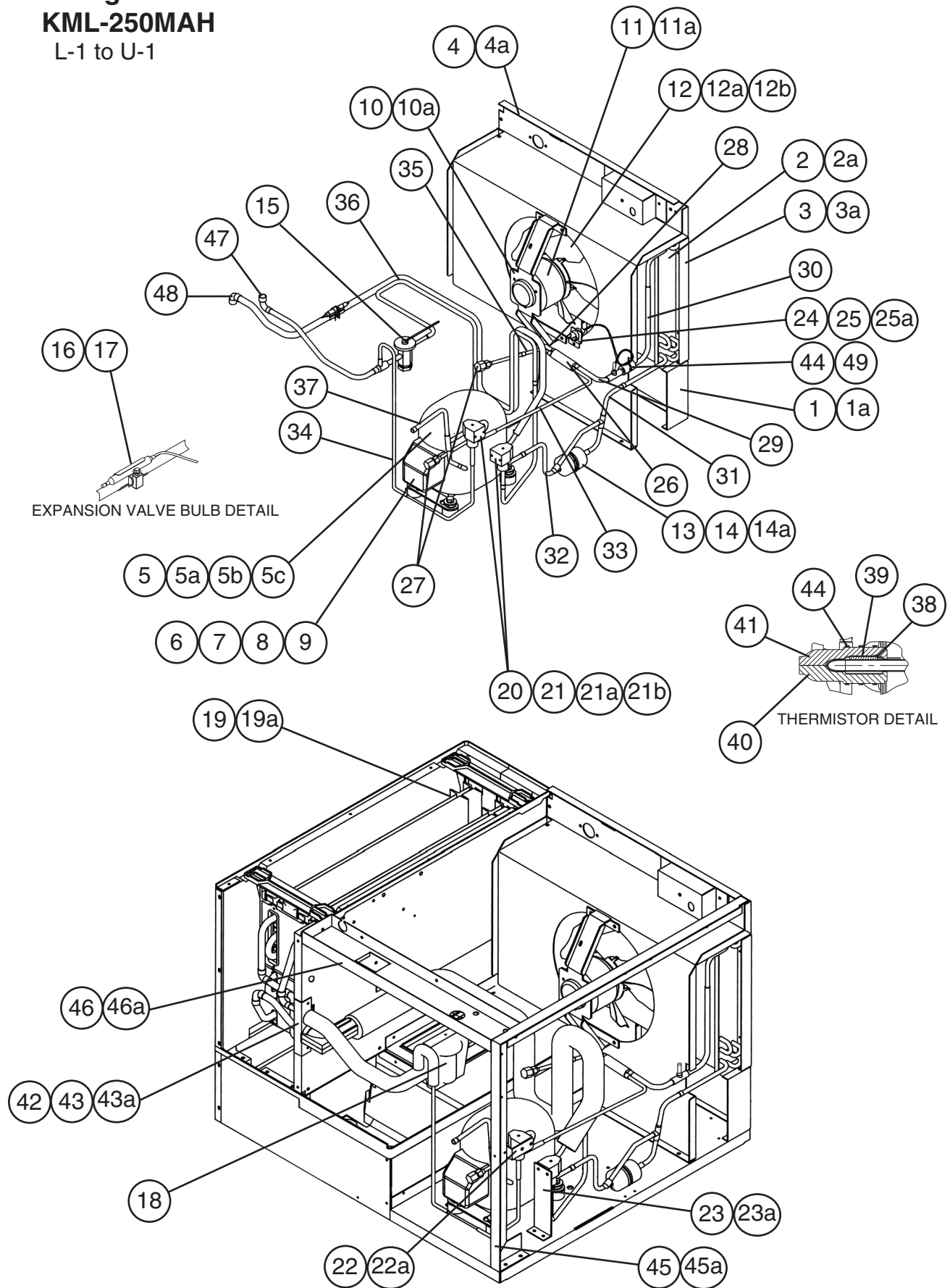

Title: B. Refrigeration Circuit Model: KML-250MAH											
Index No.	Description	Material or Model Number	Part Number	Required Number							
				L-0 M-0	M-1 to S-1	S-2 to U-1					
1	Condenser Support	GS	3A0589-01	1	1	1					
1a	T2 Screw	4x8	7P31-0408	5	5	5					
2	Condenser	-	2A0779-01	1	1	1					
2a	T2 Screw	4x8	7P31-0408	3	3	3					
3	Barrier	GS	4A0932-01	1	1	1					
3a	T2 Screw	4x8	7P31-0408	2	2	2					
4	Shroud	GS	3A1977G01	1	1	1					
4a	T2 Screw	4x8	7P31-0408	5	5	5					
5	Compressor	ASE32C3E- CAA-254	4A2456-01	1	1	1					
5a	Spacer	-	4A2500-01	4	4	4					
5b	Grommet	-	4A2281-01	4	4	4					
5c	Bolt	8x45	437889-02	4	4	4					
6	Terminal Cover	Compressor Accessory	4A2456F01	1	1	1					
7	Protector	Compressor Accessory	4A2989-01	1	1	1					
8	Protector Retainer	Compressor Accessory	4A2456F02	1	1	1					
9	Wire Kit	Compressor Accessory	4A2990-01	1	1	1					
10	Condenser Fan Motor Bracket	GS	3A1564-01	1	1	1					
10a	Hex Head Bolt w/Washer (LF)	5x12	7B0130512	4	4	4					
11	Fan Motor	SP-B25EM1	4A1179-01	1	1	1					
11a	Screw	-	436863-01	3	3	3					
12	Fan Blade	-	3A0438-01	1	1	1					
12a	Washer	-	435983-01	1	1	1					
12b	Hex Nut	-	4A1345-01	1	1	1					
13	Drier	-	4A1413-01	1	-						
			4A2666-01		1	1					
14	Drier Bracket	-	4A0807-01	1	-						
	Nylon Tie		8911-0301		1	1					
14a	T2 Screw	4x8	7P31-0408	2	-						
15	Expansion Valve	AN3/4SW65	4A1870-01	1	1	1					
16	Expansion Valve Holder	-	3A0112-01	1	1	1					
17	Clamp	SS	443461-02	1	1	1					
18	Expansion Valve Cover	-	4A1168-01	1	1	1					
19	Evaporator Assembly	-	2A0717G01	1	1	1					
19a	T2 Screw	4x16, SS	7P32-0416	4	4	4					
20	Valve Body-Hot Gas & Liquid Line	70	440352-01	2	2	2					
21	Coil-Valve	ABS-25-1-HD-2	440353-01	2	2	2					
21a	Bolt	-	440353F01	2	2	2					
21b	Truss Head Screw	4x8	7C31-0408	4	4	4					
22	Hot Gas Valve Bracket	-	4A1406-01	1	1	1					
22a	T2 Screw	4x8	7P31-0408	2	2	2					
23	Liquid Line Valve Bracket	-	436893-01	1	1	1					
23a	T2 Screw	4x8	7P31-0408	2	2	2					

Title: B. Refrigeration Circuit Model: KML-250MAH											
Index No.	Description	Material or Model Number	Part Number	Required Number							
				L-0 M-0	M-1 to S-1	S-2 to U-1					
24	Pressure Switch	ACB-1UB09	433441-07	1	1	1					
25	Pressure Switch Bracket	GS	434938-01	1	1	1					
25a	T2 Screw	4x8	7P31-0408	1	1	1					
26	Strainer	-	4A0397-01	1	1	1					
27	Access Valve	TCJ-2F20NHDU-1	457729-01	2	2	2					
28	Copper Tube (A)-High Side	Copper	3A2165-01	1	1	1					
29	Copper Tube (B)-High Side	Copper	4A2457-01	1	1	1					
30	Copper Tube (C)-High Side	Copper	3A1943G01	1	1	-					
			3A3140G01			1					
31	Copper Tube (D)-High Side	Copper	3A1311G01	1	-						
			3A2330G01		1	1					
32	Copper Tube-Line Valve	Copper	3A1948-01	1	-						
			3A2331-01		1	1					
33	Copper Tube (A)-Hot Gas	Copper	4A2321-01	1	1	1					
34	Copper Tube (B)-Hot Gas	Copper	2A1527G01	1	1	1					
35	Copper Tube-Access Valve	Copper	4A2462-01	1	1	1					
36	Heat Exchanger	Copper	2A2139G01	1	1	1					
37	Process Tube	Copper	3A1953G01	1	1	1					
38	Thermistor	-	429006-03	1	1	1					
39	Holder-Thermistor	Copper	427430-01	1	1	1					
40	Insulation-Thermistor (A)	PE FOAM	439368-01	1	1	1					
41	Insulation-Thermistor (B)	PE FOAM	439368-02	1	1	1					
42	Insulated Rubber Tube	EPDM	4A1008G01	1	1	1					
43	Insulation Holder	SS	3A1084-01	1	1	1					
43a	T2 Screw	4x8	7P31-0408	2	2	2					
44	Cable Tie	-	7920-0010	14	14	14					
45	Frame (A)	GS	2A0645-01	1	1	1					
45a	T2 Screw	4x8	7P31-0408	4	4	4					
46	Frame (B)	GS	3A0595-01	1	1	1					
46a	T2 Screw	4x8	7P31-0408	4	4	4					
47	Elbow	COPPER	4A1059-01	1	1						
48	Elbow	COPPER	417395-03	1	1						
49	Insulation Tube	L=30	7762-1020	3	3						

B. Refrigeration Circuit
KML-250MWH
 L-1 to U-1

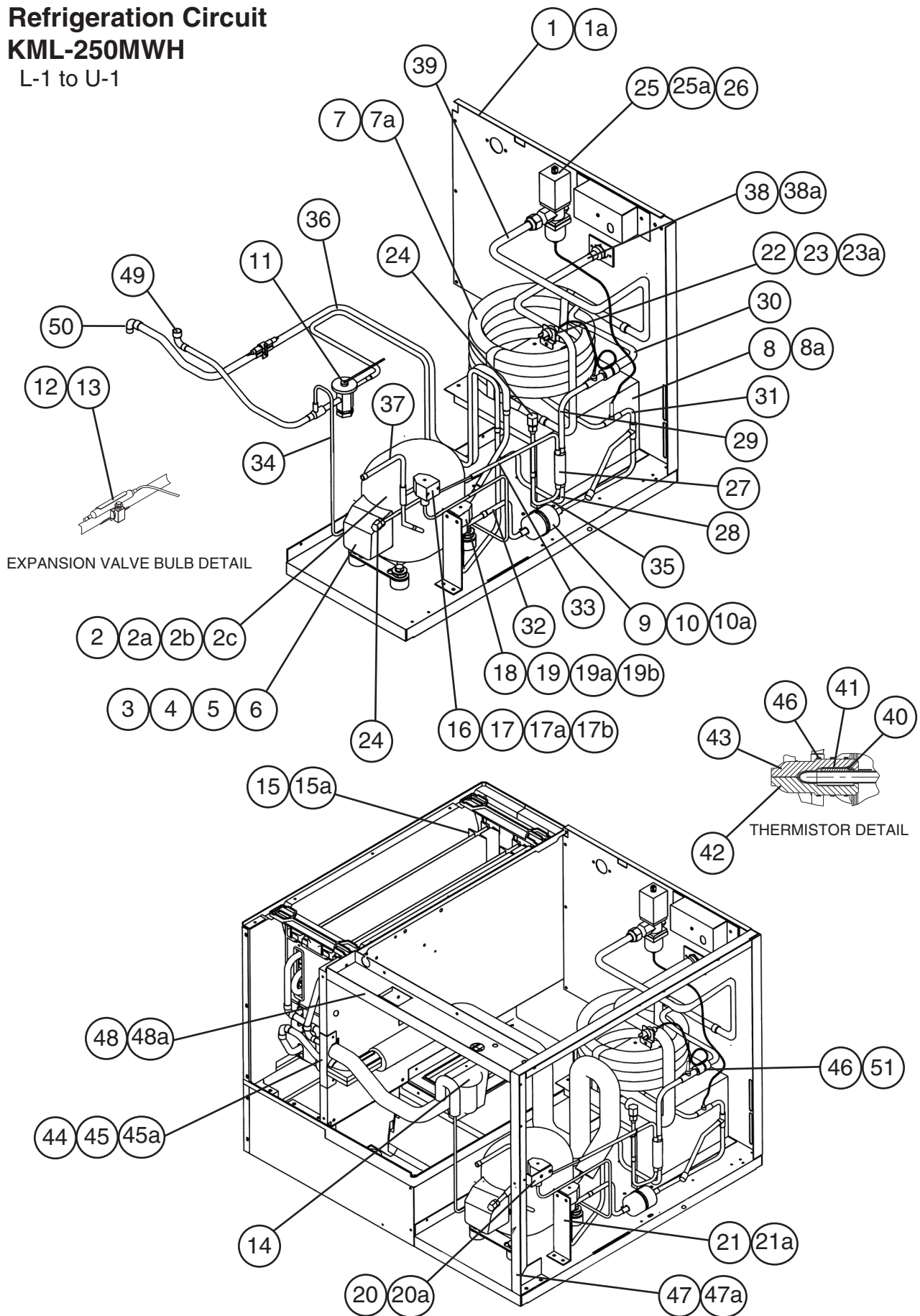

Title: B. Refrigeration Circuit Model: KML-250MWH											
Index No.	Description	Material or Model Number	Part Number	Required Number							
				L-1 M-0	M-1	M-2 to S-1	S-2 to U-1				
1	Rear Panel (B)	GS	3A0630G03	1	1	1	1				
1a	T2 Screw	4x8	7P31-0408	9	9	9	9				
2	Compressor	ASE32C3E-CAA-254	4A2456-01	1	1	1	1				
2a	Spacer	-	4A2500-01	4	4	4	4				
2b	Grommet	-	4A2281-01	4	4	4	4				
2c	Bolt	8x45	437889-02	4	4	4	4				
3	Terminal Cover	Compressor Accessory	4A2456F01	1	1	1	1				
4	Protector	Compressor Accessory	4A2989-01	1	1	1	1				
5	Protector Retainer	Compressor Accessory	4A2456F02	1	1	1	1				
6	Wire Kit	Compressor Accessory	4A2990-01	1	1	1	1				
7	Condenser	HS-0160	2A2359G01	1	1	1	1				
7a	Hex Head Bolt w/Washer (LF)	5x12	7B0130512	2	2	2	2				
8	Condenser Support	GS	2A2367-01	1	1	1	1				
8a	T2 Screw	4x8	7P31-0408	4	4	4	4				
9	Drier	-	4A1413-01	1	-						
			4A2666-01		1	1	1				
10	Drier Bracket	-	4A0807-01	1	-						
	Nylon Tie		8911-0301		1	1	1				
10a	T2 Screw	4x8	7P31-0408	2	-						
11	Expansion Valve	AN3/4SW65	4A1870-01	1	1	1	1				
12	Expansion Valve Holder	-	3A0112-01	1	1	1	1				
13	Clamp	SS	443461-02	1	1	1	1				
14	Expansion Valve Cover	-	4A1168-01	1	1	1	1				
15	Evaporator Assembly	-	2A0717G01	1	1	1	1				
15a	T2 Screw	4x16, SS	7P32-0416	4	4	4	4				
16	Valve Body-Hot Gas	-	3U0151-01	1	1	1	1				
17	Coil-Valve	ADS-15HDV-8	3U0151F01	1	1	1	1				
17a	Bolt	-	3U0151F02	1	1	1	1				
17b	Truss Head Screw	4x8	7C31-0408	2	2	2	2				
18	Valve Body-Liquid Line	70	440352-01	1	1	1	1				
19	Coil-Valve	ABS-25-1-HD-2	440353-01	1	1	1	1				
19a	Bolt	-	440353F01	1	1	1	1				
19b	Truss Head Screw	4x8	7C31-0408	2	2	2	2				
20	Hot Gas Valve Bracket	-	4A1406-01	1	1	1	1				
20a	T2 Screw	4x8	7P31-0408	2	2	2	2				
21	Liquid Line Valve Bracket	-	436893-01	1	1	1	1				
21a	T2 Screw	4x8	7P31-0408	2	2	2	2				
22	Pressure Switch	ACB-1UB04	433441-05	1	1	1	1				
23	Pressure Switch Bracket	GS	434938-01	1	1	1	1				
23a	T2 Screw	4x8	7P31-0408	1	1	1	1				
24	Access Valve	-	457729-01	2	2	2	2				

Title: B. Refrigeration Circuit Model: KML-250MWH												
Index No.	Description	Material or Model Number	Part Number	Required Number								
				L-1 M-0	M-1	M-2 to S-1	S-2 to U-1					
25	Water Regulator	V46DA-3	4A0911-03	1	1	-						
		V46DA-6	4A0911-06			1	1					
25a	Truss Head Screw	4x6	7C31-0406	2	2	2	2					
26	Male Connector	BRASS	4A1087-01	1	1	1	1					
27	Strainer	-	4A0397-01	1	1	1	1					
28	Copper Tube (A)-High Side	Copper	4A2522-01	1	1	1	1					
29	Copper Tube (B)-High Side	Copper	4A2659-01	1	1	1	1					
30	Copper Tube (C)-High Side	Copper	3A2147G01	1	1	1	-					
			3A3141G01				1					
31	Copper Tube (D)-High Side	Copper	3A2148G01	1	-							
			3A2148G02		1	1	1					
32	Copper Tube-Line Valve	Copper	3A1948-01	1	-							
			3A2331-01		1	1	1					
33	Copper Tube (A)-Hot Gas	Copper	3A1986-01	1	1	1	1					
34	Copper Tube (B)-Hot Gas	Copper	2A2256G01	1	1	1	1					
35	Copper Tube-Access Valve	Copper	4A2462-01	1	1	1	1					
36	Heat Exchanger	Copper	2A2139G01	1	1	1	1					
37	Process Tube	Copper	3A1953G01	1	1	1	1					
38	Copper Tube (A)	Copper	3A2174G01	1	1	1	1					
38a	T2 Screw	4x8	7P31-0408	2	2	2	2					
39	Copper Tube (B)	Copper	3A2149G01	1	1	1	1					
40	Thermistor	-	429006-03	1	1	1	1					
41	Holder-Thermistor	Copper	427430-01	1	1	1	1					
42	Insulation-Thermistor (A)	PE FOAM	439368-01	1	1	1	1					
43	Insulation-Thermistor (B)	PE FOAM	439368-02	1	1	1	1					
44	Insulated Rubber Tube	EPDM	4A1008G01	1	1	1	1					
45	Insulation Holder	SS	3A1084-01	1	1	1	1					
45a	T2 Screw	4x8	7P31-0408	2	2	2	2					
46	Cable Tie	-	7920-0010	14	14	14	14					
47	Frame (A)	GS	2A0645-01	1	1	1	1					
47a	T2 Screw	4x8	7P31-0408	4	4	4	4					
48	Frame (B)	GS	3A0595-01	1	1	1	1					
48a	T2 Screw	4x8	7P31-0408	4	4	4	4					
49	Elbow	COPPER	4A1059-01	1	1	1	1					
50	Elbow	COPPER	417395-03	1	1	1	1					
51	Insulation Tube	L=30	7762-1020	3	3	3	3					

C. Water Circuit
KML-250MAH, KML-250MWH
 L-0 to U-0

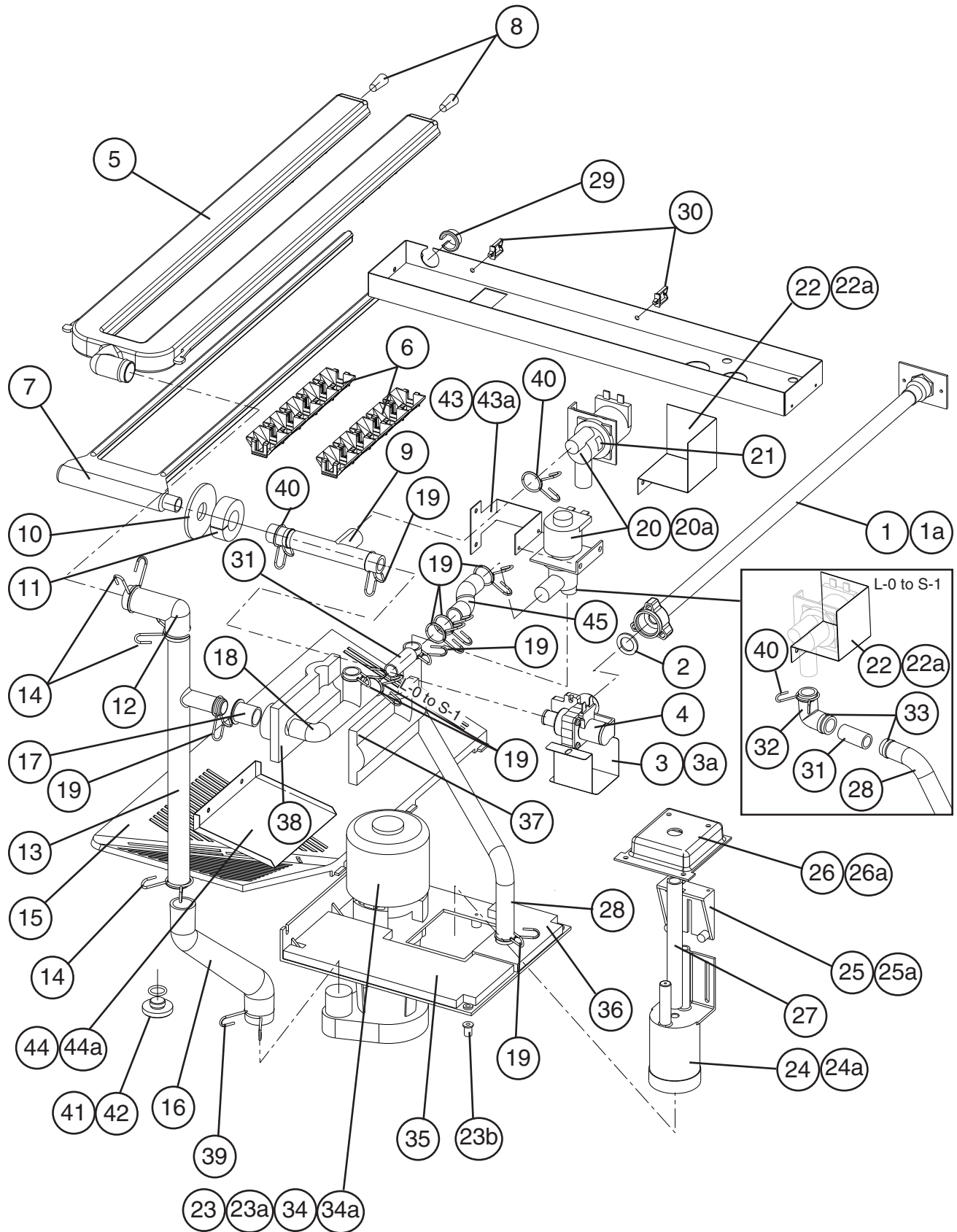

C. Water Circuit
KML-250MAH, KML-250MWH
 U-1

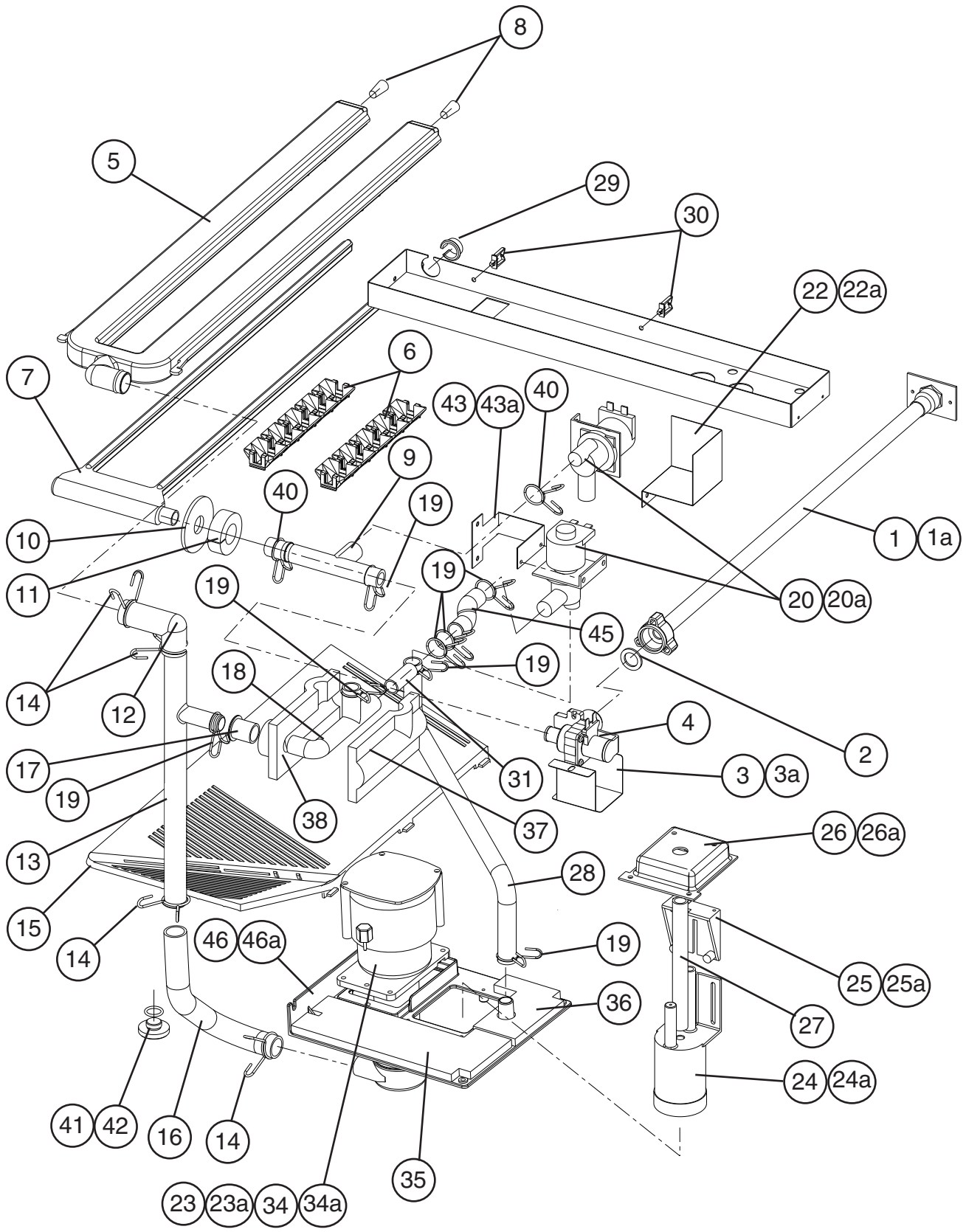

Title: **C. Water Circuit** Model: **KML-250MAH, KML-250MWH**

Index No.	Description	Material or Model Number	Part Number	Required Number										
				L-0 to R-0	S-1	S-2 T-0	U-0	U-1						
1	Water Supply Pipe	COPPER	4A0768G04	1	1	1	1	1						
1a	T2 Screw	4x8	7P31-0408	2	2	2	2	2						
2	Rubber Gasket	NR	413854-03	1	1	1	1	1						
3	Water Valve Bracket	GS	321443-01	1	1	1	1	1						
3a	T2 Screw	4x8	7P31-0408	1	1	1	1	1						
4	Water Valve	J248-072	3U0111-04	1	1	1	1	1						
5	Spray Tube	PE	1A0260-02	1	1	1	1	1						
6	Spray Guide	PE	208586-01	6	6	6	6	6						
7	Water Supply Tube	PE	2A0079-01	1	1	1	1	1						
8	Plug	-	4A0176-01	2	2	2	2	2						
9	Water Supply Tee	SANTOPRENE	4A1006-01	1	1	1	1	1						
10	Flange	EPDM	439267-01	1	1	1	1	1						
11	Insulation (E)	PE FOAM	4A0392-01	1	1	1	1	1						
12	Elbow	SANTOPRENE	4A0393-01	1	1	1	1	1						
13	Connecting Pipe	PE	3A1335-01	1	1	1	1	1						
14	Hose Clamp	25 mm, SS	427443-03	3	3	3	3	5						
15	Cube Guide	ABS	2A0660-01	1	1	1	1	1						
16	Pump Hose	EPDM	4A1007-01	1	1	1	1	-						
	Vinyl Hose	L=395	7716-2025					1						
17	Rubber Ring	EPDM	4A1004-01	1	1	1	1	1						
18	Bypass Hose	SANTOPRENE	4A1005-01	1	1	1	1	1						
19	Hose Clamp	SS, 18 mm	427443-05	5	5	8	8	8						
20	Solenoid Valve	207CB-GS1873	439322-01	2	2	-								
		DSVP12N-2LSX-120A-L1SR	4A3722-01			2	2	2						
20a	Truss Head Screw	4x8	7C31-0408	4	4	4	4	4						
21	Arrow Label	-	4A0096-01	1	1	-								
22	Solenoid Cover	GS	4A0996-01	2	2	1	1	1						
22a	T2 Screw	4x8	7P31-0408	4	4	2	2	2						
23	Pump Motor	SP-BG14LEJ16	2A0749-01	1	1	-								
		OSP-B15BEJ16	2A2861-01			1	1	-						
		PV-211BHZ1	4A4259-01					1						
23a	Truss Head Screw	4x16, SS	7C32-0416	4	4	4	4	-						
	Thumbscrew	-	415949G11					1						
23b	Wellnut	347011	4A1070-01	2	2	2	-							
24	Float Switch	163795	4A0886-01	1	-									
		213095	4A3624-01		1	1	1	1						
24a	T2 Screw	4x8, SS	7P32-0408	2	2	2	2	2						
25	Float Switch Bracket	ABS	327757-01	1	1	1	1	1						
25a	T2 Screw	4x12, SS	7P32-0412	2	2	2	2	2						
26	Float Switch Cover	ABS	3A0665-01	1	1	1	1	1						
26a	T2 Screw	4x12, SS	7P32-0412	3	3	3	3	3						
27	Vinyl Hose	L=150	7716-1216	1	1	1	1	1						
28	Vinyl Hose	L=275	7716-1519	1	1	-								
		L=320±5				1	1	1						
29	Bushing	OCB-875	428394-04	1	1	1	1	1						
30	Wire Saddle	-	4A0338-02	8	8	8	8	8						
31	Joint Pipe	-	439329-01	1	1	1	1	1						

Title: C. Water Circuit Model: KML-250MAH, KML-250MWH												
Index No.	Description	Material or Model Number	Part Number	Required Number								
				L-0 to R-0	S-1	S-2 T-0	U-0	U-1				
32	Elbow	-	433467-01	1	1	-						
33	Cable Tie	-	8911-0150	2	2	-						
34	Tooth Washer (Pump Motor Ground)	ZINC, M4	7R21-0400	1	1	1	1	1				
34a	T2 Screw (Pump Motor Ground)	4x8 SS	7P31-0408	1	1	1	1	1				
35	Insulation (A)-Pump Motor Bracket	PE FOAM	4A1052-01	1	1	1	1	-				
			4A4783-01					1				
36	Insulation (B)-Pump Motor Bracket	PE FOAM	4A1053-01	1	1	1	1	1				
37	Insulation (A1)-Bypass Hose	NP	4A1259-01	1	1	1	1	1				
38	Insulation (A2)-Bypass Hose	NP	4A1260-01	1	1	1	1	1				
39	Hose Clamp	27 mm, SS	427443-08	1	1	1	1	-				
40	Hose Clamp	20 mm, SS	427443-06	3	3	2	2	2				
41	Drain Plug	POLYACETAL	309246-01	1	1	1	1	1				
42	"O" Ring	1AP15	7611-P015	1	1	1	1	1				
43	Solenoid Valve Bracket	-	4A3137-01			1	1	1				
43a	T2 Screw	4x8	7P31-0408			2	2	2				
44	Barrier	-	4A2997-01			1	1	-				
44a	T2 Screw	4x8, SS	7P32-0408			2	2	-				
45	Vinyl Hose	L=55	7716-1519			1	1	1				
46	Pump Motor Bracket	-	2A4920G01					1				
46a	Truss Head Screw	4x16, SS	7C32-0416					4				

D. Control Box Assembly
KML-250MAH, KML-250MWH
 L-0 to M-1

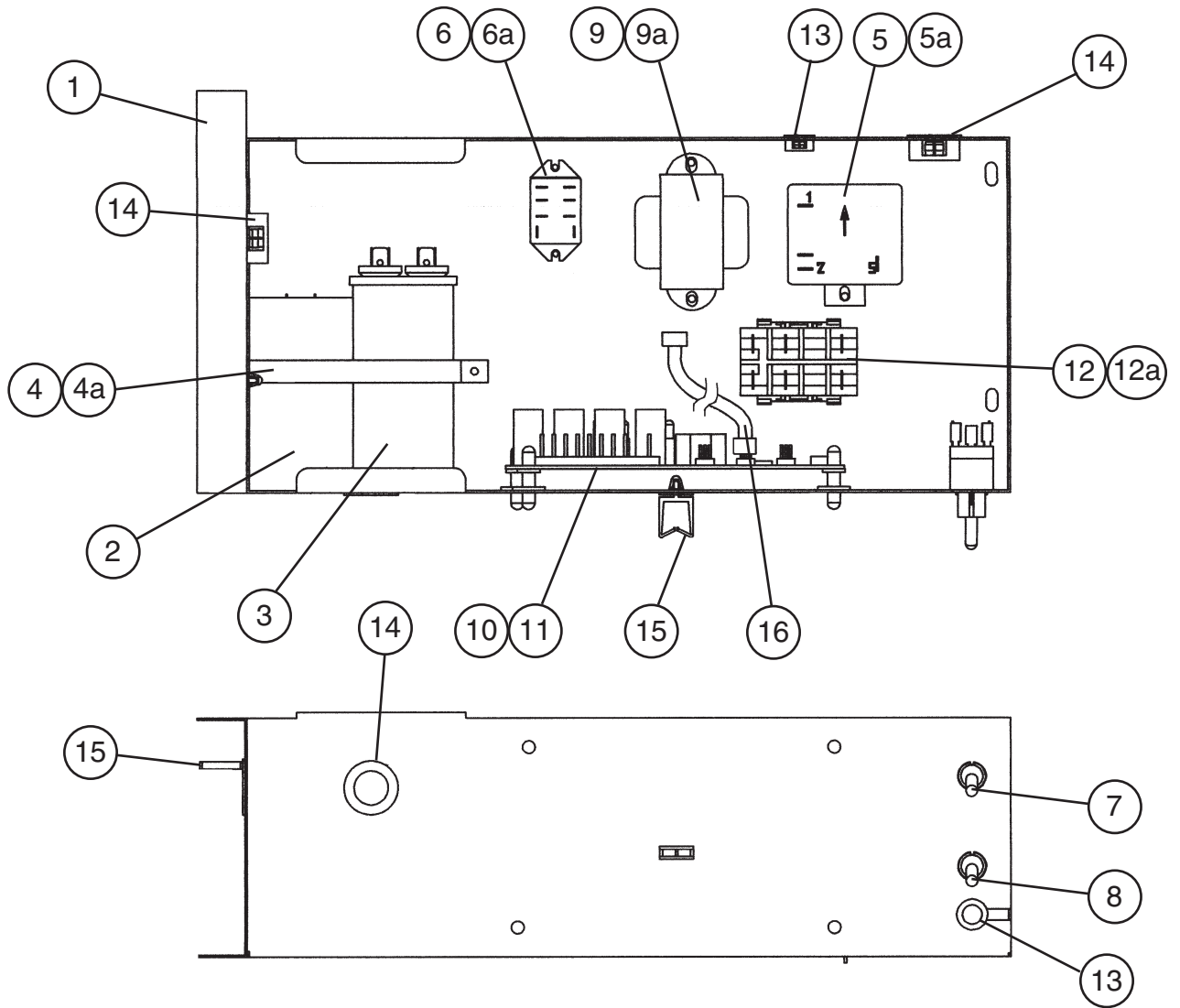

D. Control Box Assembly
KML-250MAH, KML-250MWH
 M-2 to U-1

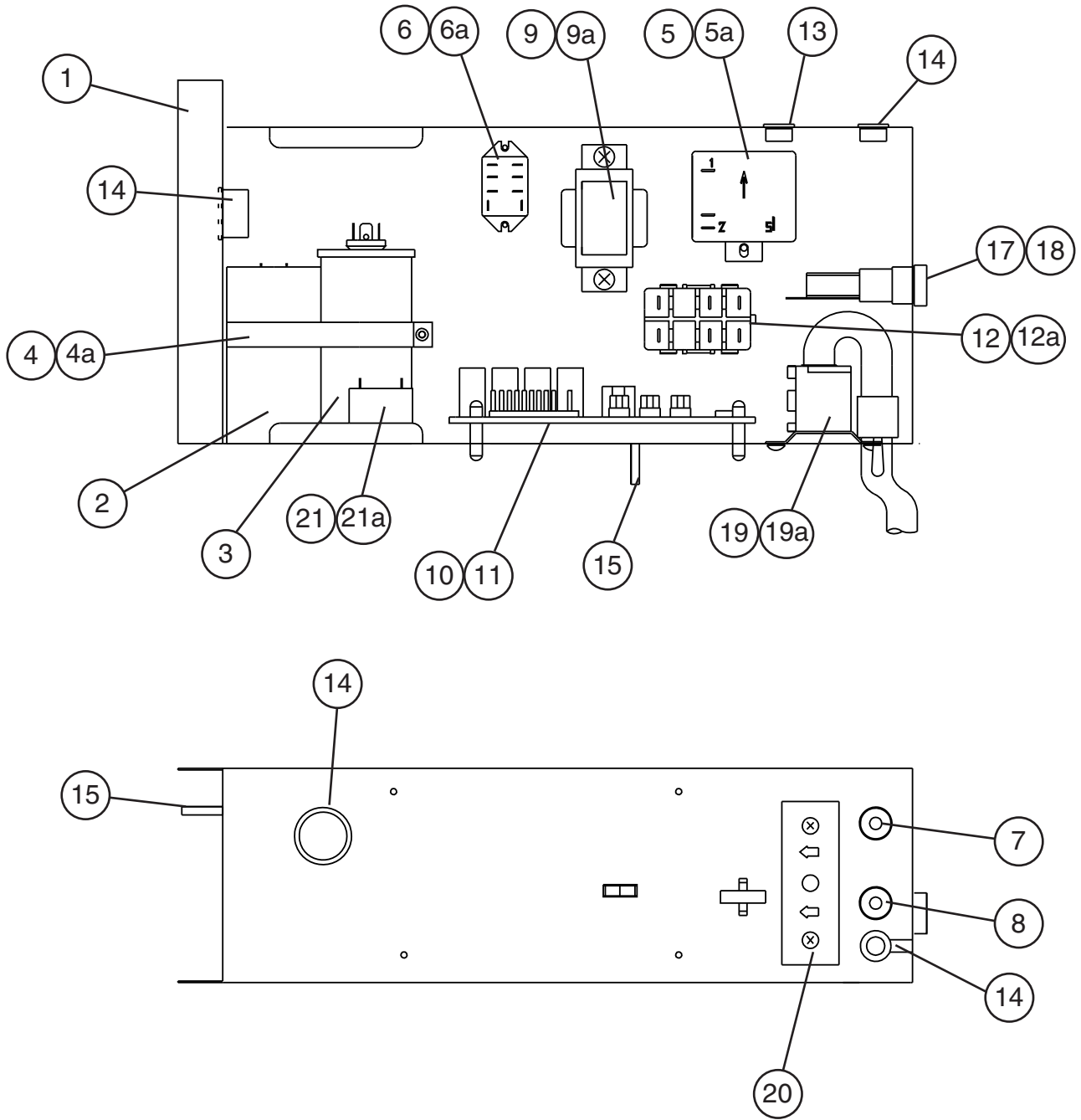

Title: **D. Control Box Assembly** Model: **KML-250MAH, KML-250MWH**

Index No.	Description	Material or Model Number	Part Number	Required Number									
				L-0 to M-1	M-2 to R-0 (F)	R-0 (G) to U-0	U-1						
1	Control Box	GS	3A1989G01	1	-								
			3A2372G01		1	-							
			3A2372G02				1	1					
2	Capacitor-Run	20MFD, 440 VAC	3A2005-01	1	1	1	1						
3	Capacitor-Start	72-86MFD, 330 VAC	3A1414-01	1	1	1	1						
4	Strap	GS	4A2262-03	1	-								
			4A2262-02			1	1	1					
4a	T2 Screw	4x8	7P31-0408	1	1	1	1						
5	Starter	3ARR3CT6U5	4A1107-14	1	1	1	1						
5a	T2 Screw	4x8	7P31-0408	1	1	1	1						
6	Relay-Drain	LY2F 120 VAC	406132-07	1	1	1	1						
6a	Tapping Screw	3x8	431415-01	2	2	2	2						
7	Toggle Switch-Control	8966K84	443119-01	1	1	1	1						
8	Toggle Switch-Service	8966K211	4A0985-01	1	1	1	1						
9	Transformer	26D285H	3A0172-01	1	1	1	1						
9a	T2 Screw	4x8	7P31-0408	2	2	2	2						
10	Control Board	HOS001A	2A1410-01	1	1	1	1						
11	Board Support	CBLS37-M	4A0336-03	4	4	4	4						
12	Magnetic Contactor	VC20	428393-01	1	1	1	1						
12a	T2 Screw	4x8	7P31-0408	2	2	2	2						
13	Bushing	OCB-500	428394-02	2	2	1	1						
14	Bushing	OCB-875	428394-04	3	3	4	4						
15	Wire Saddle	VWS4238-C	4A0338-02	2	2	2	2						
16	Resistor Wire Harness (for mechanical bin control)	-	4A2200G02	1	-								
17	Fuse Holder	HTB92I	4A0892-01		1	-							
		HTB82I	4A3449-01			1	1						
18	Fuse	AGC-10	4A0893-07		2	2	2						
19	Thermostat	YTB-3U112	4A2879-01		1	1	1						
19a	Truss Head Screw	4x8	7C31-0408		2	2	2						
20	Control Label	PES FILM	4A1758-01		1	1	1						
21	Capacitor-Water Pump	2.5MFD, 250 VAC	4A2128-05				1						
21a	T2 Screw	4x8	7P31-0408				1						

E. Label Location
KML-250MAH, KML-250MWH
 L-0 to U-1

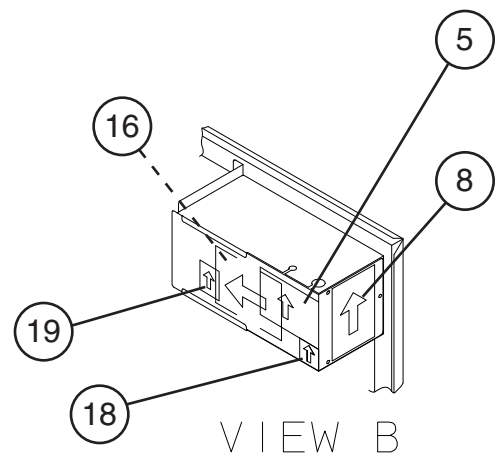
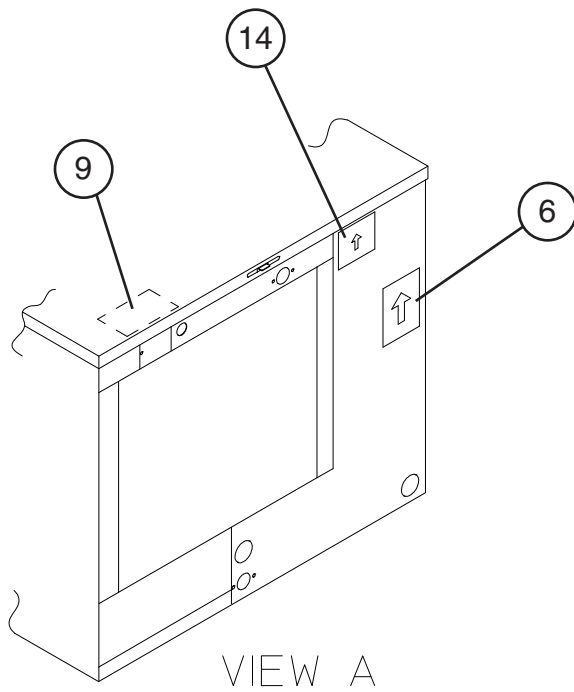
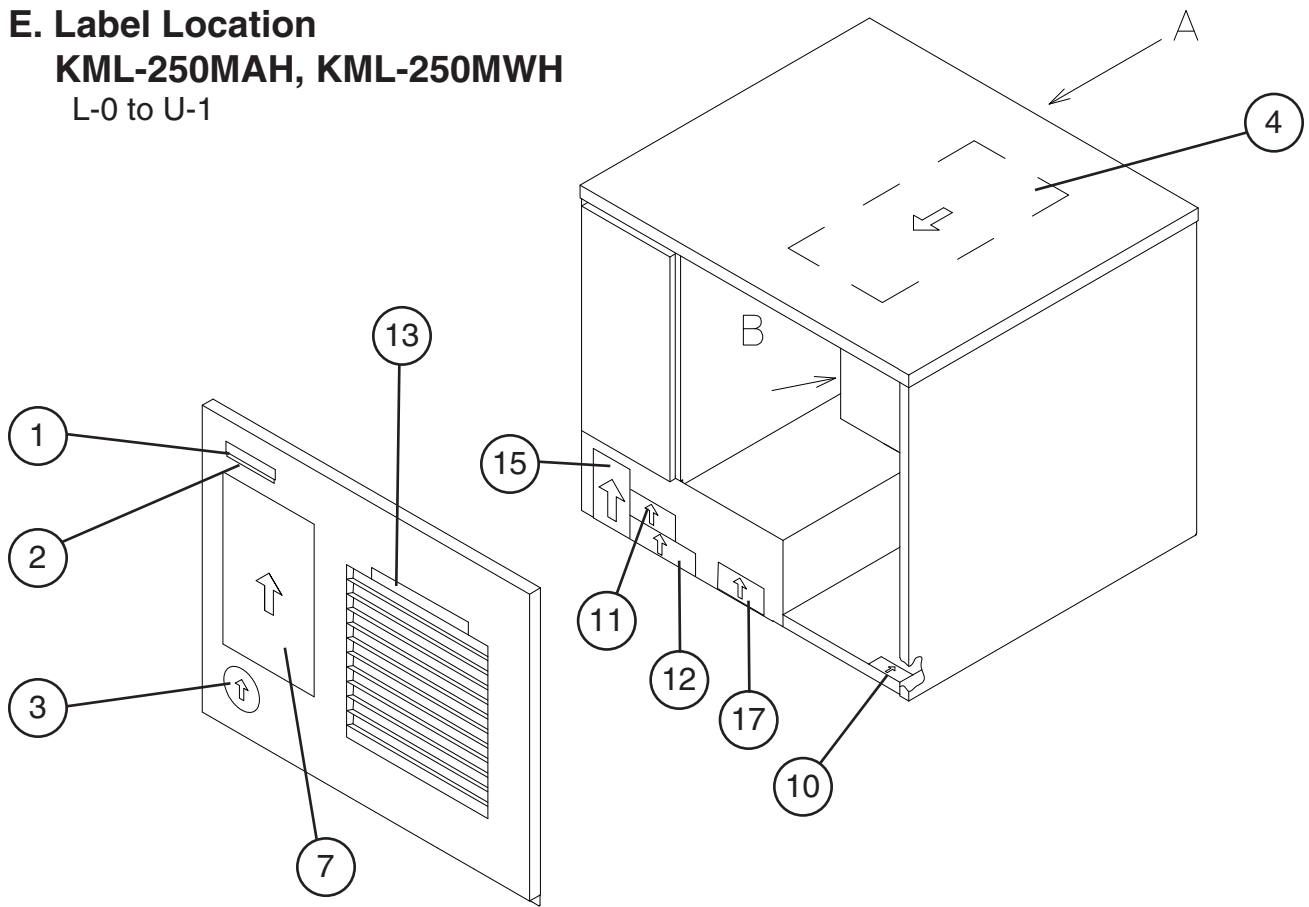

Title: E. Label Location Model: KML-250MAH, KML-250MWH													
Index No.	Description	Material or Model Number	Part Number	Required Number									
				L-0 to M-1	M-2 to T-0	U-0	U-1						
1	Emblem	PETP FILM	4A0560-01	1	1	1	1						
2	Model Number Label	KML-250MAH	4A2356-52	1	-								
		KML-250MWH	4A2356-53	1	-								
3	Label-Penguin-HA (R)	PETP FILM	4A0526-01	1	1	1	1						
4	Maintenance Label	PVC FILM	3A1873-01	1	1	-							
			3A4471-01			1	1						
5	Wiring Label	KML-250MAH	3A2057-01	1	-								
			3A2430-01		1	1	-						
			3A5421-01				1						
		KML-250MWH	3A1318-01	1	-								
			3A2430-01		1	1	-						
			3A5422-01					1					
6	Nameplate	KML-250MAH	4A2463-01	1	-								
			2A2599-01		1	1	-						
			2A5149-01				1						
		KML-250MWH	4A2531-01	1	-								
			2A2599-02		1	1	-						
2A5149-02					1								
7	Instruction Sheet	PAPER	2A2156-01	1	1	-							
			2A3845-01			1	-						
8	Manual Label	KML-250MAH	4A2549-01	1	-								
			4A2863-01		1	1	1						
		KML-250MWH	4A1090-01	1	-								
4A2863-01		1	1	1									
9	Tag-Warning: Electrical Connection	PAPER	435005-01	1	1	1	1						
10	Label-R404A	PES FILM	4A0960-01	1	1	1	1						
11	Caution Label (F)	KML-250MAH	439146-01	1	1	1	1						
12	Caution Label (K)	PVC FILM	439150-01	1	1	1	1						
13	Label-Air Filter	KML-250MAH	426177-01	1	1	1	1						
14	Instruction Label	PVC FILM	444575-01	1	1	1	1						
15	Rating Label	KML-250MAH	4A2464-01	1	-								
			2A2606-01		1	1	-						
			2A5150-01				1						
		KML-250MWH	4A2540-01	1	-								
			2A2606-02		1	1	-						
			2A5150-02					1					
16	Label-Control Board	PVC FILM	3A2220-01	1	1	1	1						
17	Label-Bin Control	-	4A2692-01	1	-								
18	Label-Fuse	PVC Film	4A2817-01		1	1	1						
19	Label-Alarm	PVC Film	4A3517-01		1	1	1						

F. Top Panel Assembly
KML-250MAH, KML-250MWH
 L-0 to U-1

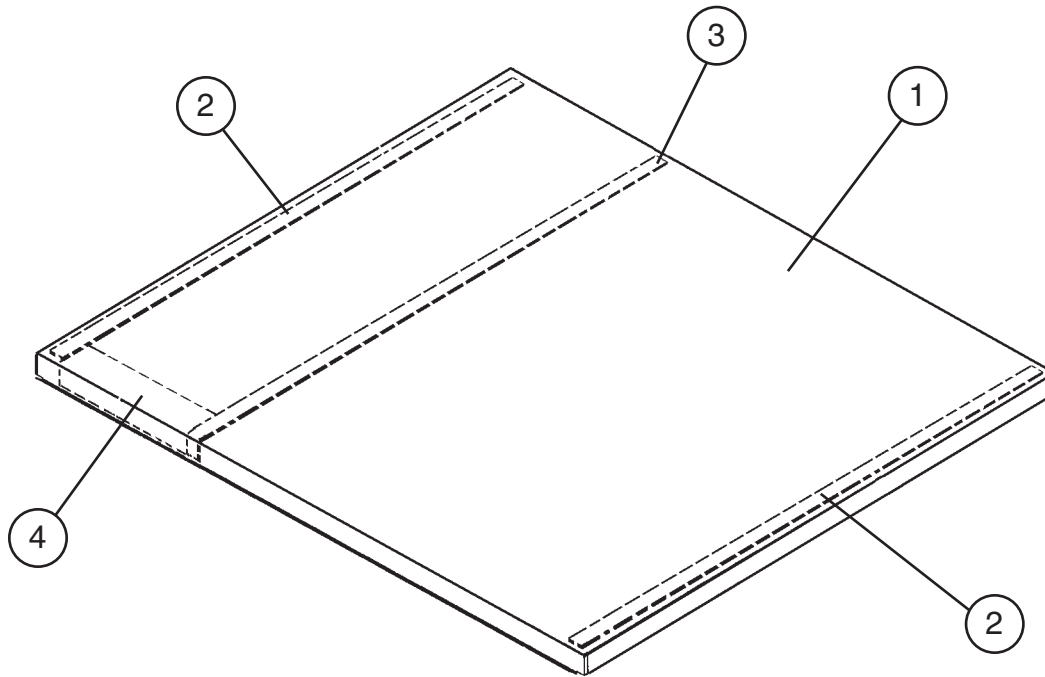

Title: F. Top Panel Assembly Model: KML-250MAH, KML-250MWH										
Index No.	Description	Material or Model Number	Part Number	Required Number						
				L-0 to U-1						
1	Top Panel	SS	2A2110-01	1						
2	Gasket	PVC	427014-04	2						
3	Gasket (A)	NORMOUNT V710	324859-03	1						
4	Insulation	PE FOAM	438012-01	1						

G. Front Panel Assembly
KML-250MAH, KM-250MWH
 L-0 to U-1

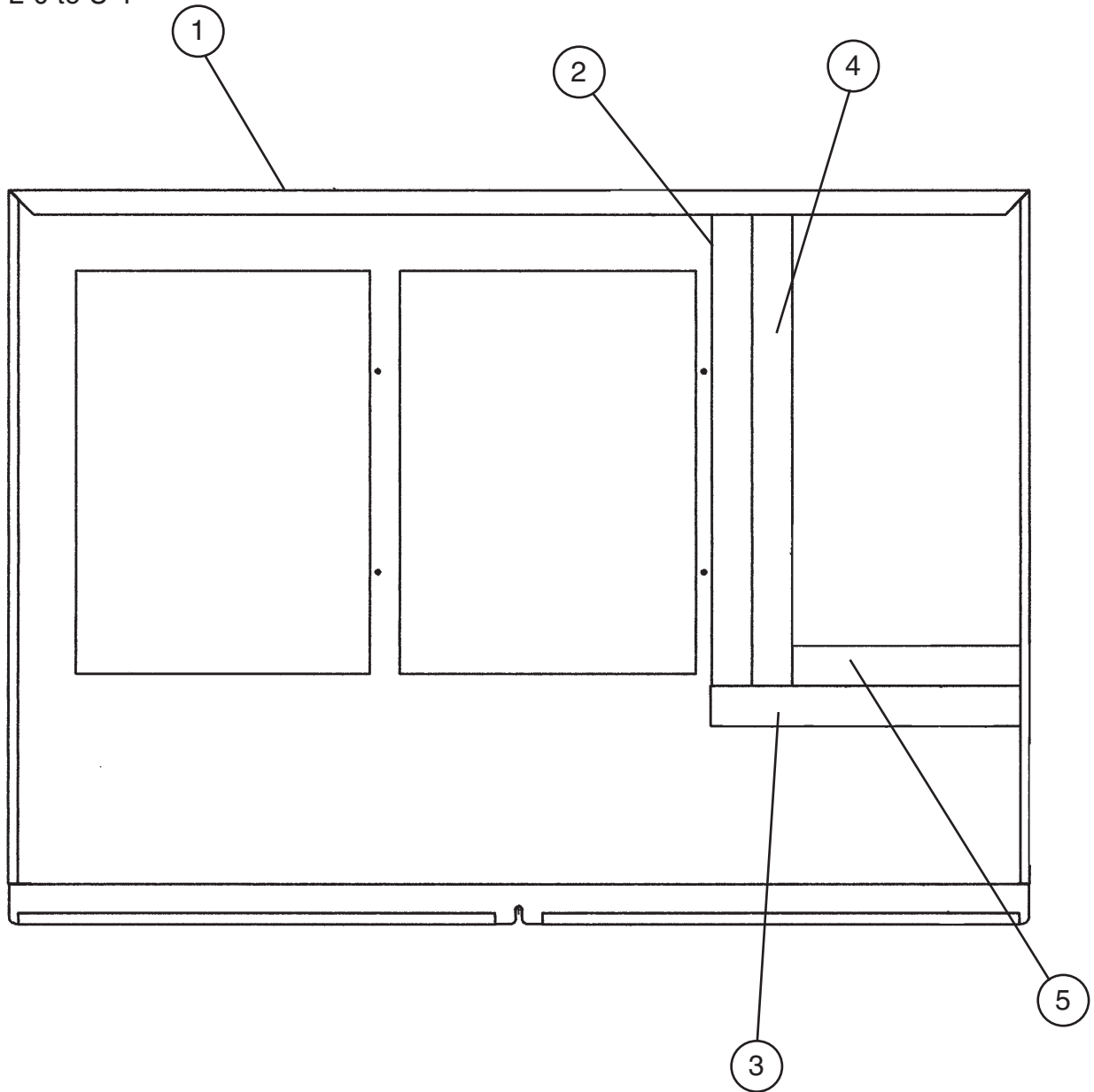

Title: G. Front Panel Assembly Model: KML-250MAH, KML-250MWH											
Index No.	Description	Material or Model Number	Part Number	Required Number							
				L-0 to U-1							
1	Front Panel (A)	KML-250MAH	2A2107-01	1							
		KML-250MWH SS	2A2107-02	1							
2	Foam Seal	L=370	4A0661L01	1							
3	Foam Seal	L=250	4A0661L01	1							
4	Foam Seal	L=370	4A1163L01	1							
5	Foam Seal	L=190	4A1163L01	1							

H. Accessories & Packaging
KML-250MAH, KML-250MWH
 L-0 to U-1

Title: H. Accessories & Packaging Model: KML-250MAH, KML-250MWH												
Index No.	Description	Material or Model Number	Part Number	Required Number								
				L-0 to U-1								
1	Instruction Manual	PAPER	91A1CE10D	1								
2	Universal Brace	GS	4A0363-01	2								
2a	Hex Head Bolt	5x12, SS	7B02-0512	2								
-	Packaging	-	2A2126A01									