

## TP-M140

MICRO CASSETTE RECORDER  
GRABADOR DE MICRO CASETES

OPERATING INSTRUCTIONS  
INSTRUCCIONES DE MANEJO  
MODE D'EMPLOI

AIWA CO.,LTD.

8B-HX7-901-01  
001106AYO-OX  
Printed in Hong Kong

**A**

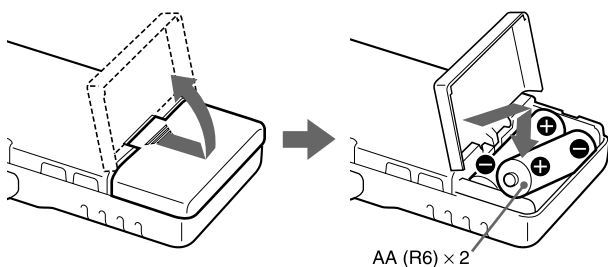

**B**

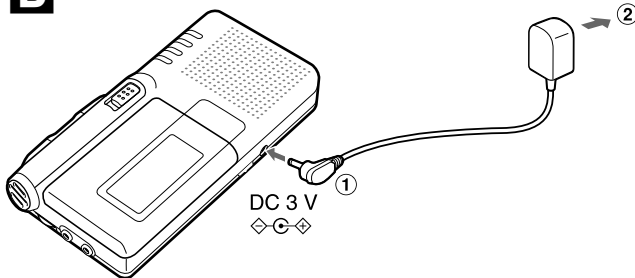

**C**

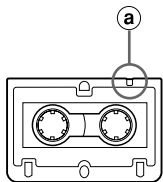

**D**

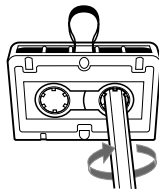

**E**

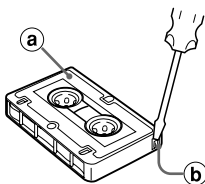

**F**

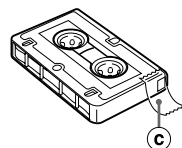

**G**



## OWNER'S RECORD

For your convenience, record the model number and the serial number (you will find it in the battery compartment of your set) in the space provided below. Please refer them when you contact your Aiwa dealer in case of difficulty.

Model No. TP-M140

Serial No.

## PRECAUTIONS

### To maintain good performance

- Do not use the unit in places which are extremely hot, cold, dusty or humid. In particular, do not keep the unit:
  - in a high humidity area such as a bathroom
  - near a heater
  - in an area exposed to direct sunlight (e.g., inside a parked car, where there could be a considerable rise in temperature)
- Keep cassette tapes, magnetic cards and other magnetic recorded materials away from the speaker as the recorded information may be erased or noise may occur on cassette tapes.
- Do not open the cassette holder during playback, recording, fast forwarding or rewinding.

## POWER SOURCE

### Using with dry cell batteries → **A**

Insert two size AA (R6) batteries with the **+** and **-** marks properly aligned.

### Battery replacement

Replace the batteries with new ones when the tape speed slows down, volume decreases or sound distorts.

### Battery life

Battery	Battery life (EIAJ Recording)
Manganese (R6P) batteries	Approx. 7 hrs.
Alkaline (LR6) batteries	Approx. 24 hrs.

Manganese (R6P) batteries

Approx. 7 hrs.

Alkaline (LR6) batteries

Approx. 24 hrs.

### Notes on dry cell batteries

- Make sure that the **+** and **-** marks are correctly aligned.
- Do not mix different types of batteries, or an old battery with a new one.
- Never recharge the batteries, apply heat to them, soak them in water, or take them apart.
- Remove the batteries if the unit is not used for a long time.
- If liquid leaks from the batteries, wipe thoroughly to remove.

### Using on AC house current → **B**

Contact your nearest Aiwa service personnel and purchase the AC adaptor Aiwa AC-D302.

① to the DC 3 V jack

② to a wall outlet

## MICRO CASSETTE TAPES

### Usable tapes

Use only micro cassette tapes with the **MICRO CASSETTE™** mark. The micro cassette has a small dent (a) on the A side so that you can distinguish the tape side even in a dark place. → **C**

### Tape slack → **D**

Take up any slack in the tape with a pencil or similar tool before use. Slack tape may break or jam in the mechanism.

### 90-minute or longer tapes

These are extremely thin and easily deformed or damaged. They are not recommended.

### To prevent accidental erasure → **E**

Break off the plastic tabs on the cassette tape after recording, with a screwdriver or other pointed tool.

Ⓐ Side A

Ⓑ Tab for side A

### To record on a cassette without tabs → **F**

Cover the tab openings with cellophane tape.

Ⓒ Cellophane tape

## MAINTENANCE

### To clean the head and tape paths → **G**

After every 10 hours of use, clean the head and tape paths with a head cleaning cassette or a cotton swab moistened with cleaning fluid or denatured alcohol. (These cleaning kits are commercially available.)

When cleaning with a cotton swab (a), wipe the recording/playback head (b), erasure head (c), pinchroller (d), and capstan (e).

### To clean the cabinet

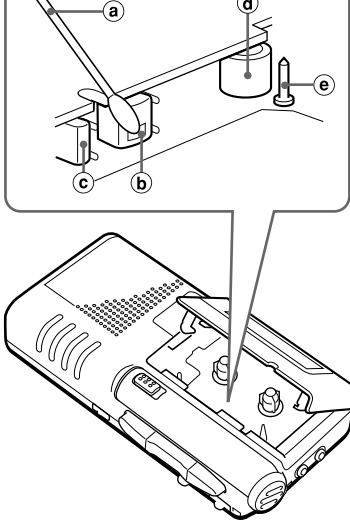

#### To clean the cabinet

Use a soft cloth lightly moistened with a mild detergent solution. Do not use strong solvents such as alcohol, benzine or thinner.

## SPECIFICATIONS

<b>Track system</b>	Micro cassette, 2 tracks 1 channel, monaural
<b>Usable tapes</b>	<b>MICRO CASSETTE™</b> (Normal position type)
<b>Frequency response</b>	250 – 5,000 Hz (2.4 cm/sec) EIAJ
<b>Tape speed</b>	2.4 cm/sec or 1.2 cm/sec switchable
<b>Microphone</b>	Electret condenser microphone (monaural)
<b>Maximum output</b>	170 mW (EIAJ/DC)
<b>Output jack</b>	EARPHONE jack (monaural mini-jack) (1)
<b>Input jack</b>	EXT MIC jack (monaural mini-jack)
<b>Other jack</b>	DC 3 V jack
<b>Speaker</b>	Diameter 36 mm, 4 ohms
<b>Recording system</b>	DC bias
<b>Erasing system</b>	Magnet erasure
<b>Power sources</b>	DC 3 V using two size AA (R6) batteries AC house current using an optional AC adaptor Aiwa AC-D302
<b>Maximum outside dimensions</b>	63.8 (W) × 122 (H) × 25.7 (D) mm (2 5/8 × 4 7/8 × 1 1/16 in)
<b>Weight</b>	Approx. 116 g (4.1 oz) (excluding batteries)
<b>Accessories</b>	Microcassette tape MC-60 (1) Size AA (LR6) dry cell batteries (2)

Specifications and external appearance are subject to change without notice.

### COPYRIGHT

Please check the laws on copyright relating to recordings from discs, radio or external tape for the country in which the machine is being used.

## TROUBLESHOOTING GUIDE

If the unit does not perform as expected, check the following table.

Symptoms	Causes
Tape does not move.	<ul style="list-style-type: none"> <li>The batteries are not inserted correctly.</li> <li>The batteries are worn out.</li> <li>The unit is in pause mode.</li> </ul>
Tape transport is unstable.	<ul style="list-style-type: none"> <li>There is slack in the tape.</li> <li>The pinch roller and capstan are dirty.</li> <li>The tape is damaged.</li> </ul>
There is no sound.	<ul style="list-style-type: none"> <li>The VOL control is turned down completely.</li> <li>The earphone is not connected firmly when listening with the earphone.</li> </ul>
The sound is too low or distorted.	<ul style="list-style-type: none"> <li>The recording/playback head is dirty.</li> <li>The batteries are worn out.</li> </ul>
The playback speed is not correct.	<ul style="list-style-type: none"> <li>The TAPE SPEED switch is set to the wrong position.</li> </ul>
Recording cannot be done.	<ul style="list-style-type: none"> <li>The erasure prevention tab on the recording side of the cassette has been removed.</li> </ul>
Tape stops during recording.	<ul style="list-style-type: none"> <li>Set the V-SENSOR switch to OFF when not using the V-SENSOR function.</li> </ul>

## INSERTING A CASSETTE → **H**

Open the cassette holder and insert a cassette with the recording/playback side **Ⓐ** facing the cassette holder.

## RECORDING FROM THE BUILT-IN MICROPHONE → **I**

- 1 Insert a cassette.**
- 2 Set the TAPE SPEED switch.**
  - 2.4: Normal recording
  - 1.2: Double time recording
  - E.g.) A 60-minute recording can be made using both sides of the MC-30 microcassette.
- 3 Press the ● button to start recording.**

The ◀ button is depressed simultaneously and the REC indicator lights. The indicator lights and goes out according to the voice input. Orient the built-in microphone to the sound source.

### Basic operation

<b>To stop recording</b>	Press the ■ button.
<b>To pause recording</b>	Set the PAUSE switch to <b>  </b> . The REC indicator lights. To resume recording, set the switch to OFF.

- The PAUSE switch is released automatically when the ■ button is pressed.

### When the end of the tape is reached

The tape stops and the ● and ◀ buttons are released automatically.

### To select the sensitivity of the microphone

Set the MIC SENS switch according to the location of recording.  
HIGH: When recording in a conference etc.  
LOW: When recording a dialogue nearby

### To monitor the sound that you are recording

Use the earphone referring to "Listening with the earphone" below. You cannot monitor the sound currently being recorded through the speaker.

### Note

The standard speed of the micro cassette recorder is 2.4 cm/sec. If you record a tape with the TAPE SPEED switch set to 1.2 and play it back on another micro cassette recorder, playback sound may not be correct.

## Recording from an external microphone → **J**

To record sound with more clarity, use an optional external microphone. The plug-in-and-power up type microphones can be used for this unit. Connect the microphone to the EXT MIC jack and set the microphone near the sound source.

### Note

When recording from an optional external microphone, move the microphone away from the main unit or the earphone to prevent howling.

## To record only above a preset sound level → **K**

Recording will start when the unit detects sound above a certain preset level. If the unit does not detect the sound for about 4 seconds, recording will pause. This prevents tape waste and empty recording.

- 1 Set the V-SENSOR\* switch to ON.**
- 2 Adjust the sensor level.**

Turn the VOL (V-SENSOR LEVEL) control in the direction of **Ⓐ** to lower the sensor level. General background noise will not be recorded, and only relatively loud sounds will be recorded.  
Turn the VOL (V-SENSOR LEVEL) control in the opposite direction of **Ⓑ** to increase the sensor level. Even relatively quiet sounds will be recorded.
- 3 Press the ● button to start recording.**

\* Voice Sensor Recording

### Sensor level adjustment

The ideal sensor level varies according to the loudness of the source sound. Experiment with the sensor level in advance to determine the optimum level before you start an important recording. Normally, align the white mark **Ⓒ** of the VOL (V-SENSOR LEVEL) control with the part **Ⓓ** first, then adjust it according to surrounding conditions.

### Note

When the recording resumes after sound detection, the very first sounds may not be recorded.

## To record from another unit → **L**

Connect the other unit to the EXT MIC jack of this unit, using the appropriate connecting cords.

- Ⓐ** To connect to stereo source equipment
- Ⓑ** To connect to monaural source equipment

### Note

- The connecting cords may vary according to the type of source equipment. Before connecting a unit, read the operating instructions of the connected unit.
- If the volume setting of the source equipment is too high, the recorded sound may be noisy or distorted. Be sure to set the volume of the source equipment to a moderate level.

**H**

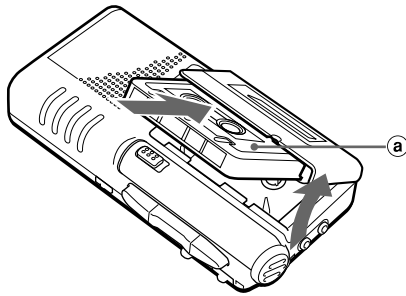

**I**

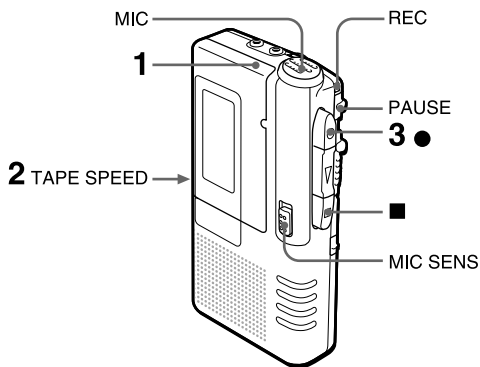

**J**

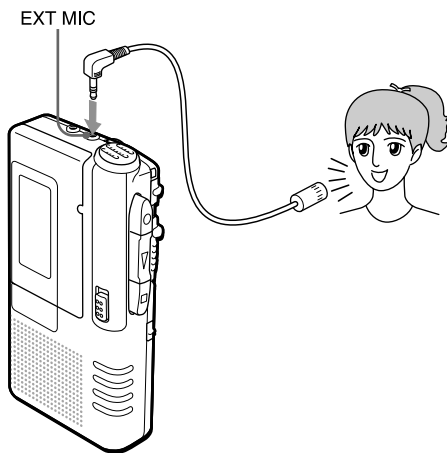

**K**

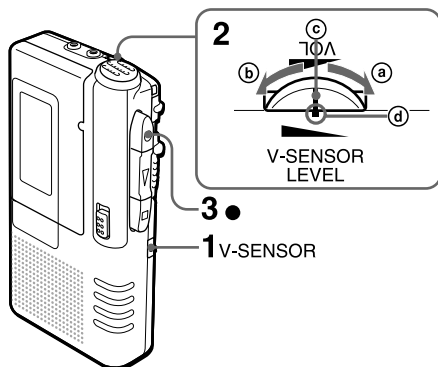

**L**

Attenuation Cable

## PLAYBACK → M

- 1 Insert a cassette.
- 2 Set the TAPE SPEED switch to the same position it was in during the recording.
- 3 Press the ◀ button to start playback.
- 4 Adjust the volume.

### Basic operation

To stop playback	Press the ■ button.
To pause playback	Set the PAUSE switch to II. To resume playback, set the switch to OFF.

- The PAUSE switch is released automatically when the ■ button is pressed.

### When the end of the tape is reached

The tape stops and the ◀ button is released automatically.

### To find the section you want to listen to

#### To fast forward/rewind

To fast forward: Slide the ◀◀FF/CUE/REW/REV▶▶ switch to ◀◀FF/CUE during stop mode.

To rewind: Slide the ◀◀FF/CUE/REW/REV▶▶ switch to REW/REV▶▶ during stop mode.

Press the ■ button at the desired point.

#### To search while monitoring high-speed sound

Keep the ◀◀FF/CUE/REW/REV▶▶ switch slid to ◀◀FF/CUE or REW/REV▶▶ during playback. When you reach the desired point, release the switch to resume playback.

### Listening with the earphone

Connect an optional earphone (3.5ø monaural mini-plug) to the EARPHONE jack. The sound does not come from the built-in speaker when the earphone is connected.

a

Attenuation Cable  
(Monaural mini-plug ↔ Stereo mini-plug)  
Cable de atenuación  
(mini-enchufe monoaural ↔ mini-enchufe estéreo)  
Câble d'atténuation  
(miniprise monoaural ↔ miniprise stéréo)



b

Attenuation Cable  
(Monaural mini-plug ↔ Monaural mini-plug)  
Cable de atenuación  
(mini-enchufe monoaural ↔ mini-enchufe monoaural)  
Câble d'atténuation  
(miniprise monoaural ↔ miniprise monoaural)

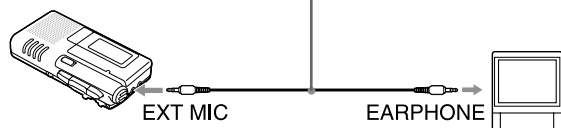

M

