

# FEATURES OF THE RHFE-1510F

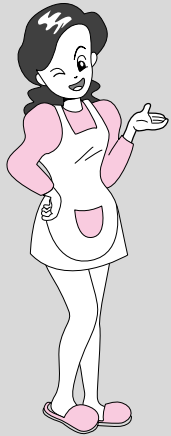

The new RHFE-1510F is the largest model in Rinnai's Forced Flued heater range. It has been developed for commercial installations, particularly those where there are obstructions at floor level which may impede the air flow from the downflow heaters in the range.

## CHARACTERISTICS

1. Input is 17.4kW (Output is approximately 13.6kW).  
The RHFE-1510F is suitable for heating large spaces such as offices, schools, rooms, etc.
2. The air discharge is at the top of the appliance, this helps to provide good air circulation in areas where obstructions such as desks and shelves would obstruct a downflow heater.
3. The horizontal louvres are manually adjustable, and the vertical louvres have an automatic 'swing' function which can be used to sweep the air flow from left to right, or can be stopped in a particular direction.
4. Ignition is electronic, with push button control.
5. Temperature control is by electronic thermostat.
6. The control panel door has a lock which can be used to prevent the controls being tampered with.
7. Air for combustion is taken from the outside, keeping the room air clean.

This heater must be installed correctly by an authorised person, and the installation must conform to local regulations, The installation must also comply with instructions supplied by Rinnai.

# CONTENTS

IMPORTANT NOTES .....	5
NAME AND FUNCTION OF EACH PART .....	11
OPERATION INSTRUCTIONS .....	12
PRODUCT INSTALLATION .....	15
MAINTENANCE .....	27
PRE SERVICE CHECK .....	28
TROUBLESHOOTING THE HEATER .....	29
SPECIFICATIONS .....	30
SERVICE CONTACT POINT .....	31



## Warranty

As the purchaser of this high quality Rinnai Space Heater you are provided with the following conditional warranty.

Heat Exchanger:	5 years*
All other Parts:	1 year
Labour:	1 year

\*Full Heat Exchanger replacement (parts only) in the first five years, thereafter reducing as follows, subject to conformity. A replacement heat exchanger will be supplied at the normal selling price less the following discounts.

Year 6:	80% discount
Year 7:	60% discount
Year 8:	40% discount
Year 9:	20% discount
Year 10:	10% discount

This warranty does not cover cleaning and normal wear and tear, calls of this nature may be chargeable. Please check the troubleshooting chart on page 29 before asking for a service call. You may be able to overcome the problem, or the heater may be operating normally. Service calls to a heater that is operating normally may be chargeable, even if the heater is under warranty.

The installer is responsible for the heater's correct installation.

### CONDITIONS

1. It is a condition of this warranty that the heater shall have been serviced annually during its lifetime by a suitably qualified engineer, and that it must have been installed and used in accordance with these instructions.
2. Failing to use genuine Rinnai spare parts, or attempting to repair the appliance yourself may invalidate the warranty.
3. The serial number of the heater must be supplied prior to any claim being processed.

## Installation Instructions

### IMPORTANT INFORMATION

1. Gas safety (Installation & Use) regulations 1998 are the 'Rules in force'. In your own interest and that of safety, it is law that all gas appliances are installed by competent persons in accordance with the above regulations. Failure to install appliances correctly could lead to prosecution. Other persons should NOT attempt to install this equipment.
  2. Unpack the appliance and check it carefully. If it appears to have any defects or damage DO NOT INSTALL, contact your supplier.
  3. The heater is intended to be used to raise the temperature in a room or office, etc. Do not use it for any other purpose without consulting Rinnai UK.
  4. This appliance is safe if correctly installed and sited. Please comply carefully with these instructions.
  5. This appliance is to be used with Natural Gas (G20) or Propane (G31) only. The data plate on the side of the unit will show which gas it is set up for.
  6. Installation must be carried out in accordance with the current issue of the following:
    - Building regulations issued by the Department of the Environment and Building Standards (Scotland) Regulations.
    - I.E.E. Wiring regulations for electrical installations.
    - Gas safety (Installation and Use) Regulations current issue.
    - BS 5871 part 1:2001
    - BS 5440 part 1 and 2
    - BS 6891
    - BS 5482
    - Local byelaws
    - Health and safety at work etc. Act 1974
    - Children and Young persons act 1933, revised 1952
- Such other specifications and regulations that may supersede or complement the above documents.

# IMPORTANT NOTES

## CAUTION

- Do not use for any other purpose except heating.



- These clearances should be maintained at all times.

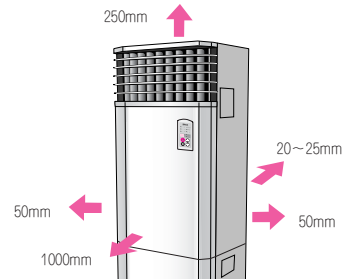

- Do not allow curtains or other flammable materials to come into contact with the unit.



- Keep flammable materials, trees, shrubs etc away from flue terminal.

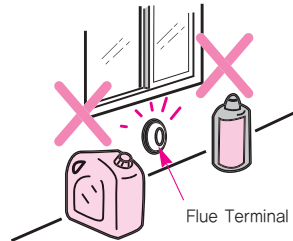

- Supervise children near unit.



- Do not allow young children or the infirm to sleep in front of the unit.

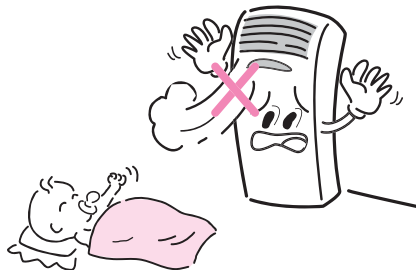

## CAUTION

- Do not allow children to 'post' articles in the louvres.



- Do not place any articles containing liquids on top of the unit.

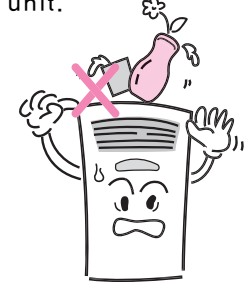

- Do not spray aerosols on the unit whilst it is in operation.

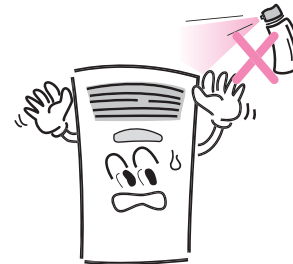

- Do not place articles on or against the unit.

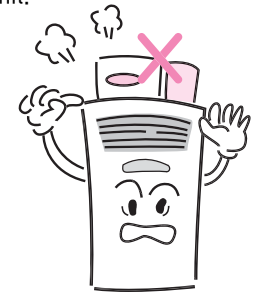

- If you smell gas, never turn ON or OFF a ventilator or other electrical appliance.

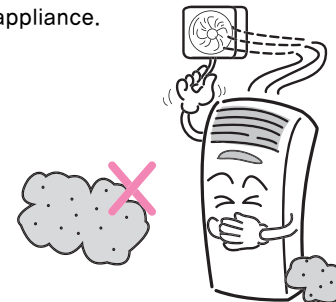

- Do not install heater under shelves or other fixtures where there is a danger of articles falling behind the appliance.

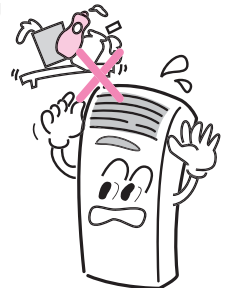

# Flue Terminal Position

## Minimum Distances

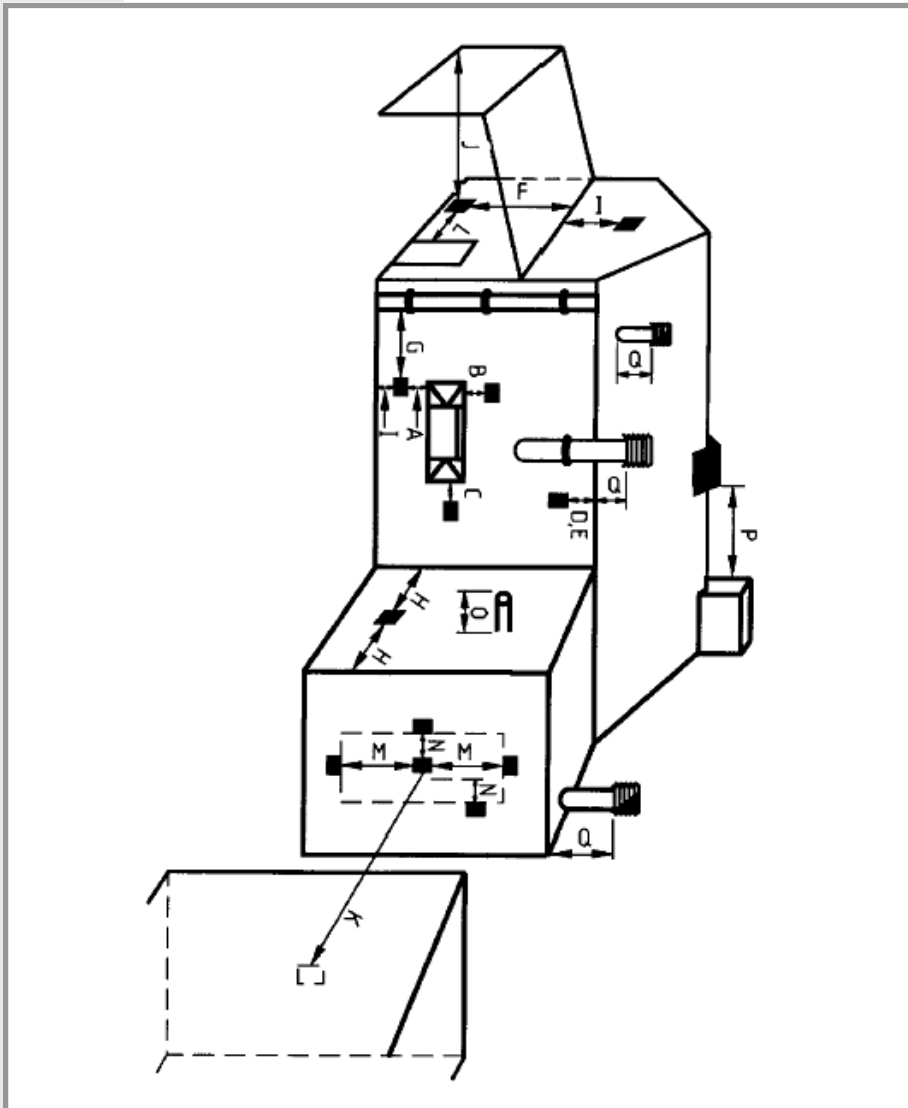

Dimension	Terminal Position	Distance
A	Directly below an opening, air brick, opening windows, etc.	300mm
B	Above an opening, air brick, opening window, etc.	300mm
C	Horizontally to an opening, air brick, opening window, etc.	300mm
D	Below gutters, soil pipes or drain pipes.	75mm
E	Below eaves.	200mm
F	Below balconies or car port roof.	200mm
G	From a vertical drain pipe or soil pipe.	150mm
H	From an internal or external corner.	200mm
I	Above ground, roof or balcony level.	300mm
J	From a surface facing the terminal.	600mm
K	From a terminal facing a terminal	1200mm
L	From an opening in a car port. ( e.g. door, window) into a dwelling	1200mm
M	Vertically from a terminal on the same wall.	1500mm
N	Horizontally from a terminal on the same wall.	300mm
O	From the wall on which the terminal is mounted	N/A
P	From a vertical structure on the roof.	N/A
Q	Above an intersection with roof.	N/A

## WARNING

### About parts and accessories

- Only use the parts designated for this product.

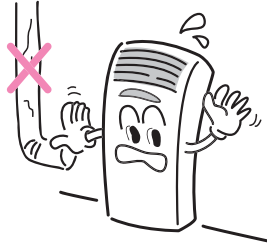

### Flue manifolds

- Flue terminal must be installed outside.
- Use it properly according to the instructions.

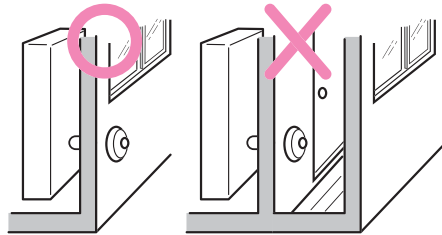

- Flue is not designed to be positioned under floor, or below the level of the heater.
  - Flue terminal must be kept clear of obstructions and plants because the combustion gases and vapour come out from flue terminal.
  - Flue terminal must be kept clear of bags or empty cans so it does not get blocked.

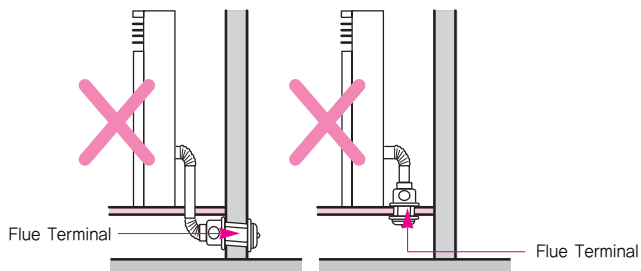

## WARNING

### Standard installation of Flue Manifolds

- Before installation, check that the gas type and pressure are compatible with the appliance.

- Standard installation of Flue Manifold
  - Diagram on the right shows minimum clearances and distances from obstructions.
  - Flue fittings must be positioned away from flammable materials and obstructions that effect surrounding airflow.
  - Install flue fittings at an angle of 2 degrees from the surface.

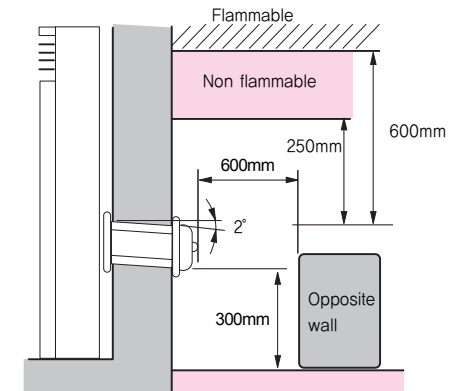

- Side clearances.

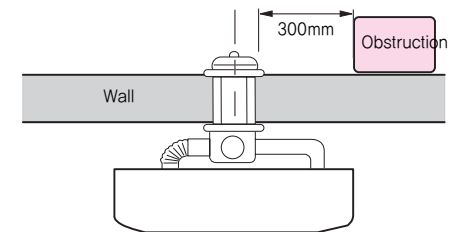

- Flue fittings must be positioned away from flammable materials.



# NAME AND FUNCTION OF EACH PART

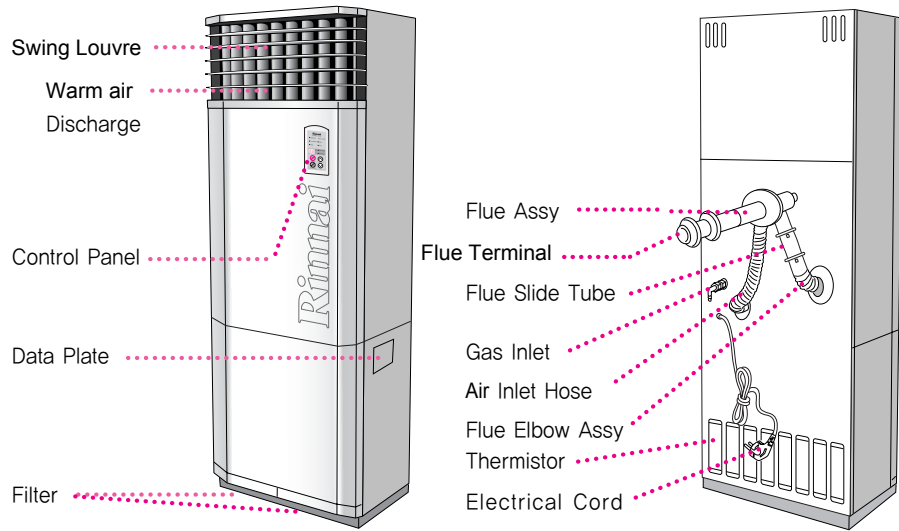

## OPERATION

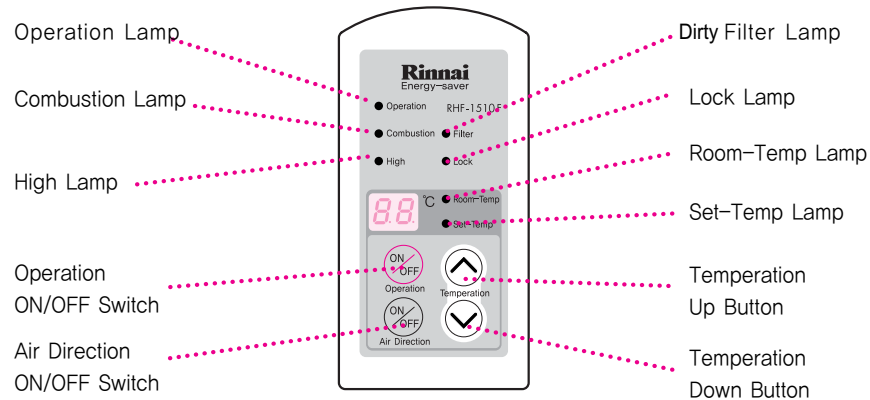

# OPERATION INSTRUCTIONS

## Caution

- Check points and preparations before use
  - Insert the power plug firmly in to the power point.
  - Alternatively, remove plug and wire into a double-pole switched, 3A fused, spur.
  - This product is for single phase 230V 50Hz.

※Keep the power cord away from the flue tube.

Open the gas valve fully.



## Heater Operation Instructions

### ■ Operation

- Push the operation ON/OFF switch.
- The operation lamp glows and the combustion fan rotates.
- After about 20 seconds, the combustion lamp glows.
- The warm air comes out within about 20 seconds after the combustion lamp starts to glow.
- In the early stage of operation, the heater runs in forced rapid mode for about 2 minutes.

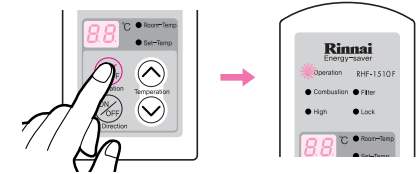

### ■ Stop

- Push the operation ON/OFF switch.
- The operation lamp will go out and the heater will stop.
- The fan will continue to run for 3–4 minutes until the heater is cool.

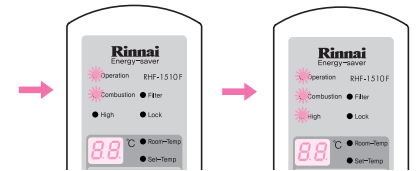

### ※Caution

- Do not turn the heater off by unplugging it from the power point or closing the inside gas valve during combustion. It can cause damage to the heater.

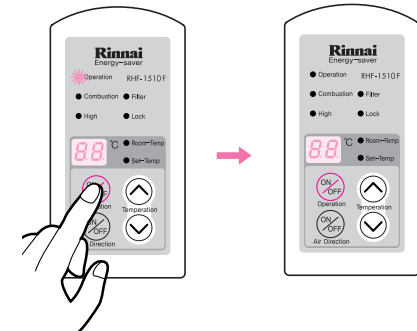

## Air direction adjustment

### ■ Air direction adjustment

- The direction of air can be adjusted from right to left, by using the air direction button.
- The direction of air flow can be set to a particular direction if required by simply pushing the air direction button at the point where the louvre blows the air in the direction you desire.
- Upwards or downwards air direction is adjusted by moving the 5 horizontal louvres manually.
- The degree of adjustment should be within 30 degrees upward or downward. If the louvres are adjusted in excess of 30 degrees, normal air discharge may be interrupted and can cause overheat.

#### ※Caution

- Adjust the horizontal louvres by grabbing the side edge of louvre if the unit is operating. Louvres may become extremely hot during heating, resulting in burns.

Upwards or downwards air direction is adjusted by manual operation.

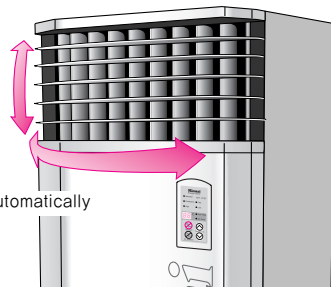

Air direction to the left or right is automatically adjusted by automatic swing louvres.

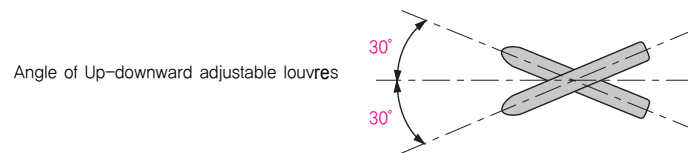

## Control Panel Lock Function Instructions

- Locking the control panel will prevent people tampering with the adjustments.
- If lock lamp is on, the control buttons will not alter the operation of the heater. (For Safety, if you push the stop button during operation, the heater will stop.)
- To alter the heater, you must cancel the lock function.

### ■ Instructions using the lock function

- Push the air direction button and temperature up button at the same time for 5 seconds. When the Lock lamp starts to glow the Lock function is set.

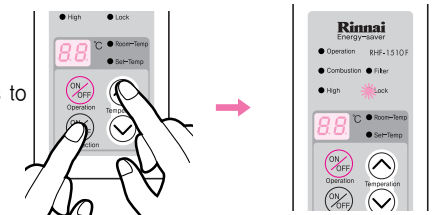

### ■ Cancelling Lock function

- Push the air direction button and temperature up button at the same time for 5 seconds when the lock function is on. The lock lamp will go off and the lock function is cancelled.

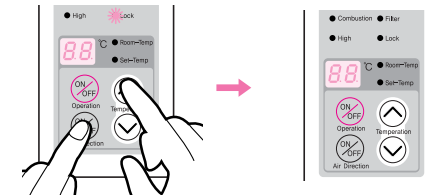

### ■ Setting Room Temperature

- Set the room temperature you desire using the temperature up button and temperature down button. (16°C– 30°C)

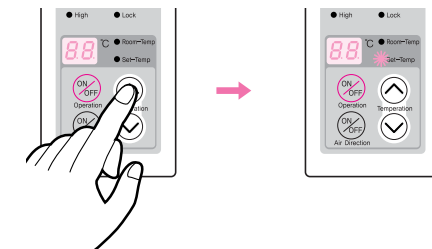

#### ※Caution

- The heater does not operate when the current temperature is higher than the desired temperature. If more heating is needed, push temperature up button to set the temperature higher than the current temperature.
- The current temperature of the heater is the temperature of air inlet so it does not always correspond with the room temperature. Adjust the temperature considering current temperature and sensible temperature.
- While the temperature is altered the set temp lamp will be lit and the set point will be displayed. After 5 seconds the current temp lamp will light and the current temperature will be displayed.





# P

## RODUCT INSTALLATION

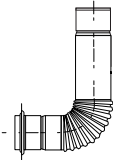
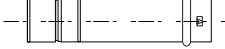
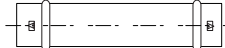
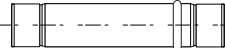
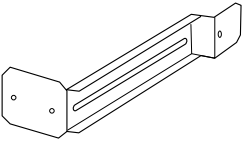
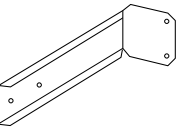
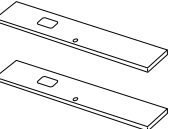
### Check the parts included in installation kit.

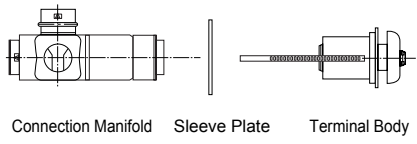
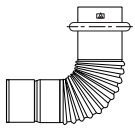
- Remove parts from carton and check that all parts shown below are included in the installation kit.
- Common parts

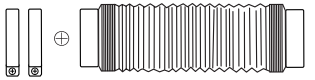
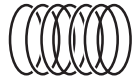
Parts	Shape	Quantity
Elbow Tube		1
Sliding Tube		1
Support Tube		1
Adapter Tube		1
Side Spacer Brackets		4
Wall Brackets		2
Back cover		2
Screws for back cover (M4 black screws)		10
Screws for side spacer brackets (M4 screws)		8
Screws for side spacer brackets and wall brackets (M5 black screws)		4

Parts	Shape	Quantity
Flue Manifold Terminal Set	 <p>Connection Manifold   Sleeve Plate   Terminal Body</p>	1
Elbow		1
Screws for Flue elbow (M4 screws)		3
Air Inlet Hose Ass'y		1
O-rings		7
Others	Concrete nails	 4
	15mm M4 screws	 3



## Product Installation

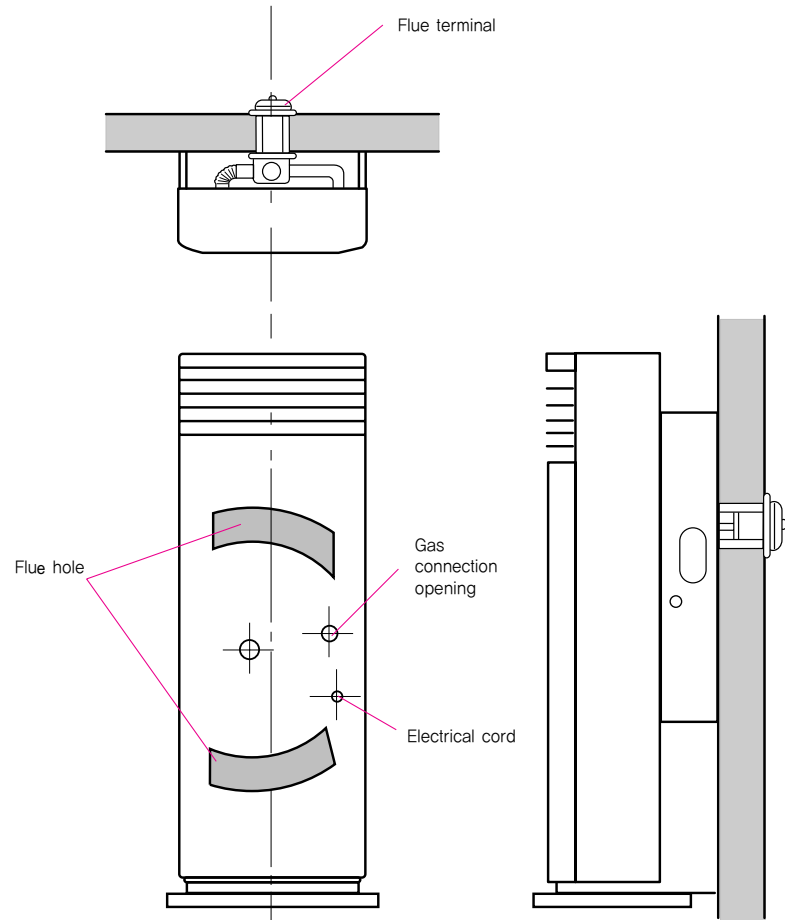

## Flue Manifold Position

- Check the following before drilling the flue hole.

### Flue Hole Position

- Centre of hole for flue manifold can be drilled anywhere within the shaded area. (When extending flue manifold, the method is different.)
- Attachable wall thickness is 240- 400 mm for standard flue manifold. Other than this thickness, optional extra flue manifold must be used.

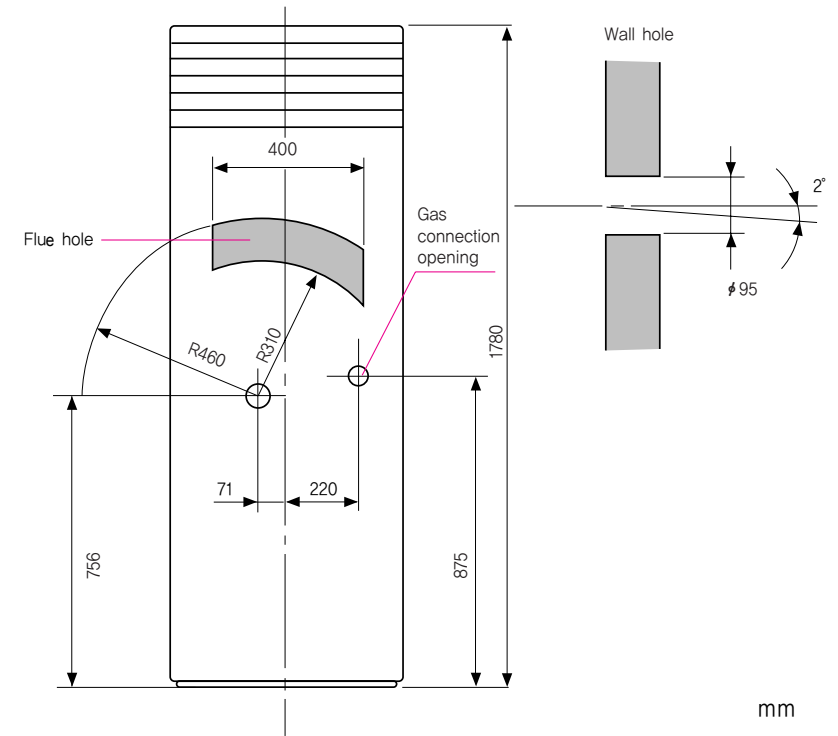

## Installation Procedure

- Flue Manifold and Product Installation

### FF type flue manifold connection

#### ■ Air inlet hose connection

- Connect flexible hose to heater and tighten band with screw driver.

- Connect air inlet hose to the flue manifold. Tighten band with screw driver to secure hose

※Do not bend the hose too much when connecting.

#### ■ Flue manifold connection

- Connect the extendable flue tube to the exhaust port of the flue manifold. Adjust the length of the extendable tube to meet exactly with the flue hole height. Pipe must not be extended beyond the Red line.

#### ■ Changing connection of flue manifold

- The manifold can be adjusted as shown, depending whether the position of the Flue is high or low. When connecting horizontally, connect flue manifold using the elbow as shown below right.

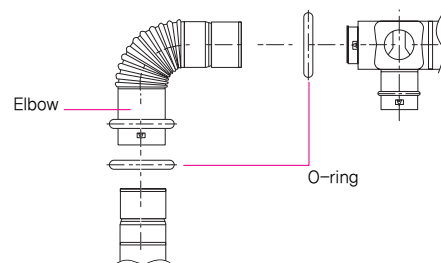
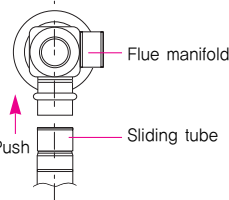
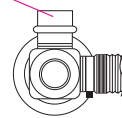
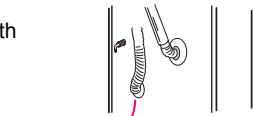

#### ■ Attach back spacer brackets

- Using the 8 screws provided, attach the 4 Back Spacer Brackets to the back of the heater.

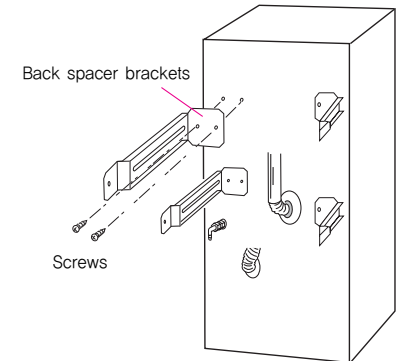

#### ■ Attach wall brackets, back spacer brackets.

- Using the 4 black M5 screws provided, attach the wall brackets to the top back spacer brackets.

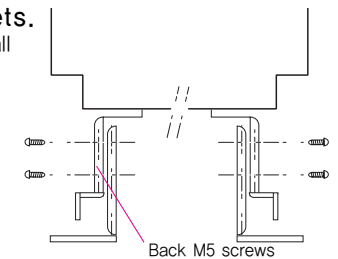

#### ■ Fixing the heater

- Find the location of each hole then fix the heater firmly with the screws provided.

#### ■ Attach Rear Side Covers

- Attach the left and right side rear covers provided with the heater.

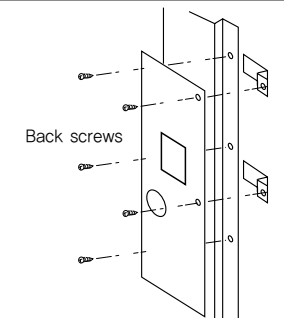

## Example of flue manifold installation

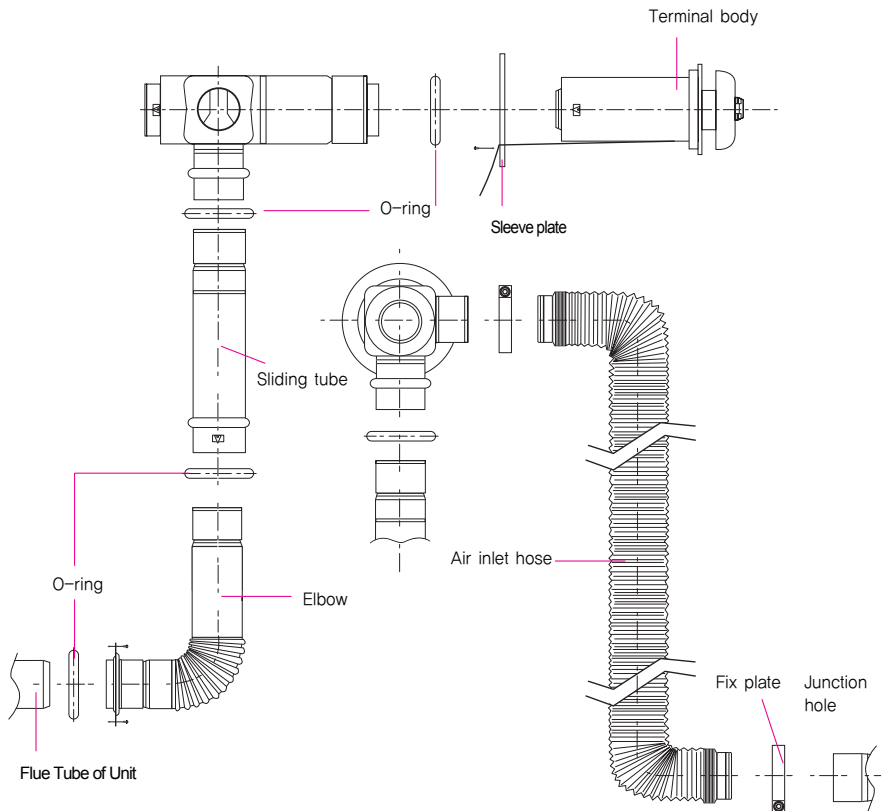

### Caution

- Put grease on connecting O-rings.
- Use the same air inlet hose length as the length of the flue manifold.

## Example of flue tube extension

### (Example1)

- Possible to change the direction of flue by changing the position of the stop end.

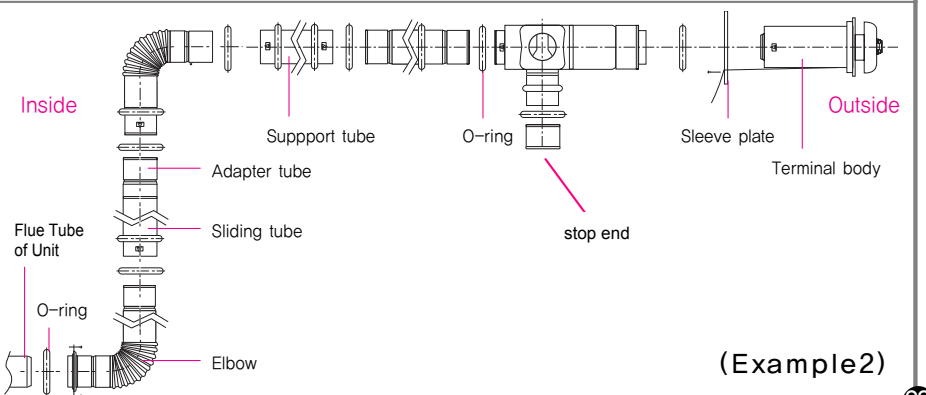
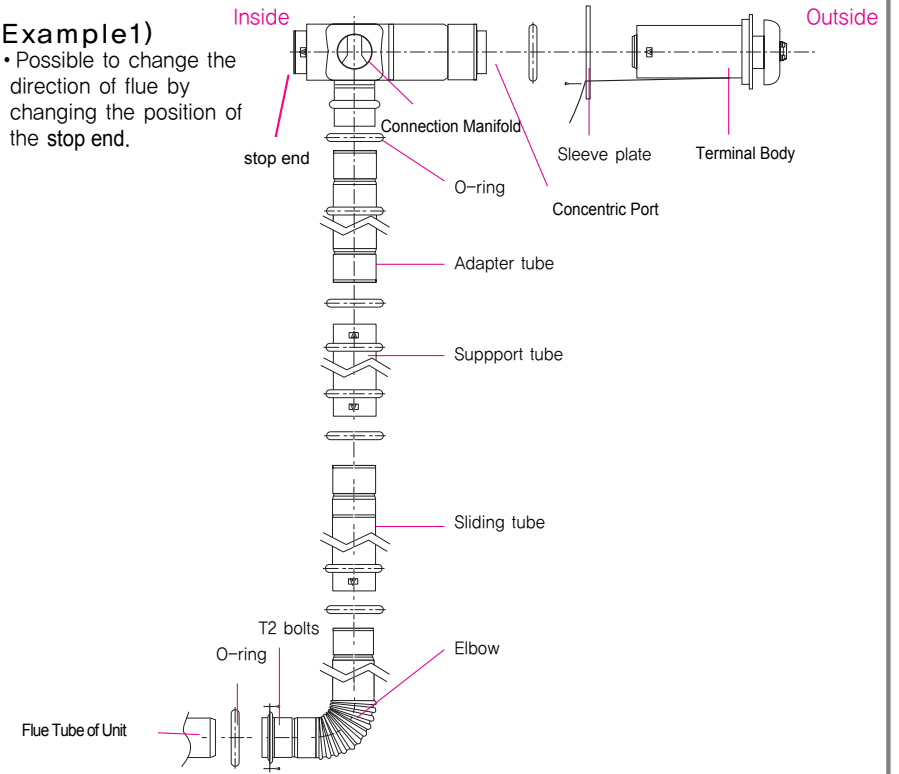

### (Example2)

## Flue Manifold Terminal Connection

### Handling Flue Manifold Terminal

#### ■ Separation of Flue Manifold Terminal

- Separate the Terminal into 3 parts; sleeve plate, connection manifold, and the terminal body.

This is done by pulling the outside terminal from the connection manifold, then pull sleeve off outer terminal. Spread springs out so they are slightly bigger than the hole.

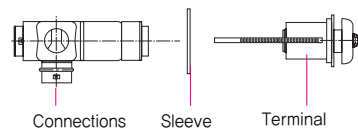

#### ■ Attaching terminal body

- Push the terminal body through from outside.
- Install the terminal body tilting at a slight angle to the surface and stick it firmly to the wall.
- Put silicon between the wall and the flue terminal so there is no gap after fixing the flue terminal.

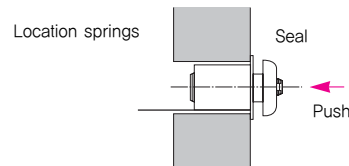

#### ■ Fixing the Terminal body

- Insert the sleeve plate over the spring loaded ties of the terminal body. Be careful not to damage the O-ring on the body.
- Pull the ties tight so the sleeve plate sticks to the wall then fix the ties on sleeve plate lugs. They will extend 2-3 slots past start point.
- Flange is marked This way up with an arrow or the word Top, and must be installed this way.
- Secure the sleeve to the wall using the 4 holes of the flange.
- After sleeve is secure, cut off the rest of the tie. (The parts that stick through to the inside.)
- Insert connection manifold into Sleeve. Secure with the 3 screws provided. The manifold can be turned to any angle.

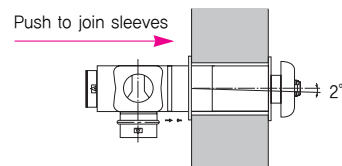
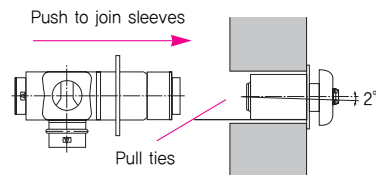

## Extension of Flue Manifold

### Caution

- Extension tube (optional extra) is needed for any extension.
- Maximum extension is 5m in length. This allows for a maximum of 3 bends.

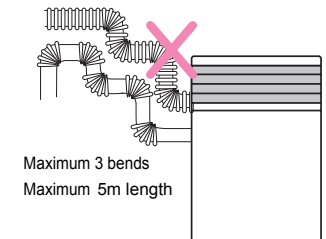

- Condensed water can form in the tube when extended. Make sure there are no low spots. Do not run the tube horizontally. If condensed water comes in to the heater, the water tray can overflow. Do not run flue more than 2m vertically.

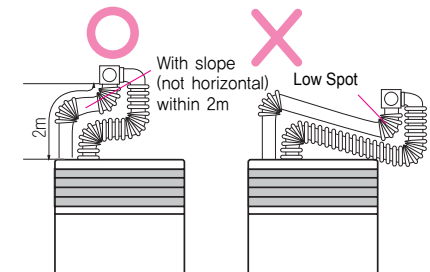

- Do not extend to places where you cannot see such as under floors, or over ceiling.

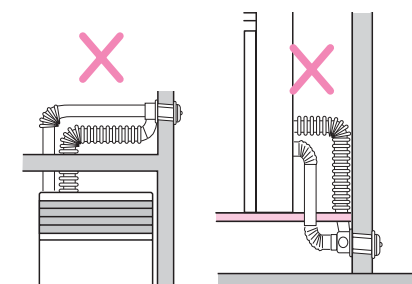

- The length of air inlet hose and the length of flue tube must be same.

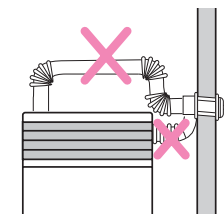

# T

## esting the Unit

Purge air and swarf from gas line.

- Connect gas (1/2 inch BSP). Connection can be easily reached from the top rear of the unit.
- Check for escapes, using soapy water after turning gas on.
- Remove fan filters.
- Remove front covers, 2 screws at the bottom of lower cover, 2 at bottom of upper cover.
- Remove inner right hand cover (5 screws).
- Remove test point screw, attach pressure gauge to test point, (on solenoid valve). Turn power on.

**(CAUTION: 240V inside unit).**

- Turn thermostat to 'HI', turn control to 'ON'. Unit should ignite within 10 seconds. (If unit does not ignite first time it will spark again after 10 seconds).
- If unit does not ignite, there may be air in the gas line. Turn control 'OFF' then 'ON' again.
- Check pressure compared to value on page 30, regulator is factory set, and should be correct.
- If pressure is incorrect, check supply before altering regulator.
- Turn control to 'OFF' position, remove pressure gauge and replace test point screw.
- Re-light unit, on 'HI' setting. Slide thermostat control slowly towards the 'LO' position, the heater will modulate down, then cut out. (Depending on the room temperature).
- Turn the power off.
- Replace the casing.
- Turn power on.
- Recheck operation.

# W

## iring Diagram

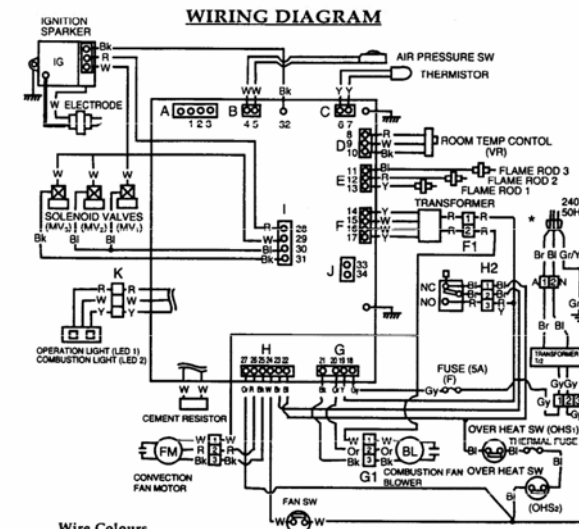

**Wire Colours**

R	:Red
Gy	:Grey
Bl	:Blue
W	:White
Pl	:Purple
Bk	:Black
Gr/Y	:Green/Yellow
Y	:Yellow
Or	:Orange
Pk	:Pink

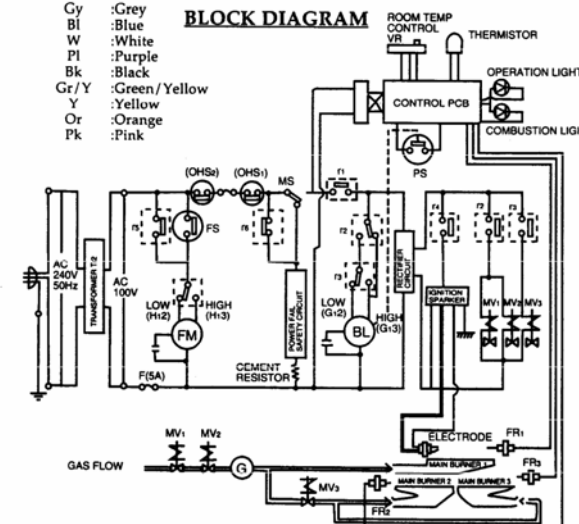

# Dip Switch Settings

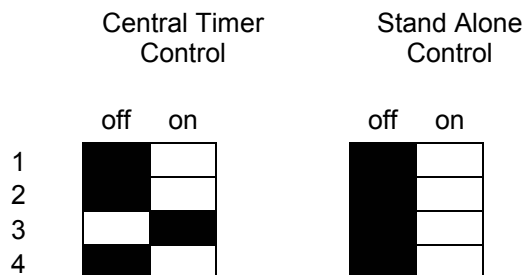

- 1 Computer Programming
- 2 Computer Programming
- 3 Central Control System
- 4 Emergency Cut Off

If controlled by a central timer, dip switch 3 must be in the ON position.

To use a time clock you will also require a transformer and sub PCB available from Rinnai.

When a time clock is used the appliance On/Off button will not operate.

If Emergency cutoff loses signal unit will stop.

Emergency Cut Off can not be used with Central Control System.

# Fault Codes

HI	Overheat Switch	Blocked Flue Terminal
		Blocked Air Filter
		Power Failure
		Warm Air Obstruction
		Gas Type
		Gas Pressure
		Convection Fan coil resistance
		PCB voltage to Convection Fan
		PCB voltage to Overheat Circuit
		Thermal Fuse Resistance
Overheat Switch Resistance		
CI	Room Temp Sensor Faulty	Room Temp Thermistor Resistance
C2	Overheat Temp Sensor Faulty	Overheat Thermistor Resistance
H6	Overheat	Thermal Fuse
dl	Sparker Failure	PCB
		Sparker input voltage
		Spark Gap
bl & Combustion Lamp	No Ignition	Flame Rod carboned up
		PCB
		Blocked burner ports
		Blocked Flue Terminal
		Gas Type
		Combustion Fan
		Gas Pressure
EO	Communication Error (Ghost Flame)	PCB
		Flame Sensor
		Sparker
b3 + Combustion Lamp	Flame Failure	Physical Blockages
		Flame Rod
n2	Air Proving Device	Blocked Flue
		Faulty PCB
		Combustion Fan
		Kinked/disconnected air tube
		Heat Exchanger Blocked
		Air Proving Sensor
n1	On/Off Button Faulty	Check On/Off switch
		sub PCB
		PCB

# M MAINTENANCE

## Caution

### ■ Fan filters

- To protect the fan from dust or lint, the RHF-1510 is fitted with 2 fan filters.
- unit and remove dust with a soft brush or vacuum cleaner.
- Replace filters after cleaning.
- Weekly cleaning is recommended during the heating season.

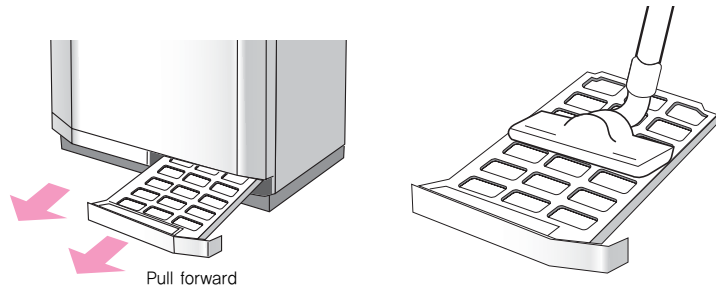

# P PRE SERVICE CHECK

- Before asking for service call please check the following.
- These points are part of the normal operation of the unit.

Problem	Cause and remedy
• The combustion lamp does not light on the first attempt after not using the heater for a long time or in early season.	Repeat the operation to discharge the air from the gas tube until ignition occurs.
• Smoke or strange smells are produced on the first trial light up after installation or in early season.	This is caused by dust on the heat exchanger, and will stop after a short time. Use it with ventilation for this time.
• Sharp clicking noises at ignition, when the unit cuts down on the thermostat, or goes out.	This is simply expansion noise from the heat exchanger.
• "Puck" noise during operation	This is the ignition noise.
• Warm air does not start when the burner lights.	The fan is started automatically after a short delay. This is to allow the heat exchanger to warm up, helping to avoid cold draughts.
• "Shee-"noise during operation	This is a gas passing noise.
• Metal squeaking noise after extinguishing, or after turning off.	This is a metal expansion/contraction noise due to heating/cooling of the parts inside the heater.
• Convection fan continues to run after turning off.	This is to remove the residual heat from the heat exchanger. The fan will stop when the unit cools down.
• Steam is discharged from the flue terminal.	High efficiency appliances tend to discharge water vapor on cold days. This is normal.
• Other cases than above, contact Rinnai UK.	



### Danger

Do not attempt to disassemble or repair the product unless trained to do so.

# TROUBLESHOOTING THE HEATER

Refer to the list below.

- It may not be broken.
- Please check this list before asking for service.
- If it does not work after checking, then call Rinnai UK.

Problem	Check point	Remedy
No operation lamp	<ul style="list-style-type: none"> <li>• Is the power plugged in</li> <li>• Is the circuit breaker or fuse disconnected</li> <li>• Is it during power cut</li> </ul>	<ul style="list-style-type: none"> <li>• Plug in</li> <li>• Check the fuse and the circuit breaker</li> <li>• Re-ignite manually after power is restored</li> </ul>
Burner does not ignite	<ul style="list-style-type: none"> <li>• Is the gas valve fully opened</li> <li>• Is there any air left in gas tube</li> </ul>	<ul style="list-style-type: none"> <li>• Open the valve fully</li> <li>• Repeat the run/stop manually and check the ignition operation</li> </ul>
Combustion stops during operation	<ul style="list-style-type: none"> <li>• Is there dust inside the filter</li> <li>• Is the louvre obstructed</li> <li>• Is the flue terminal obstructed</li> </ul>	<ul style="list-style-type: none"> <li>• Clean the filter</li> <li>• Check the louvre</li> <li>• Check the flue terminal</li> </ul>
Takes too long to warm the room	<ul style="list-style-type: none"> <li>• Is there dust inside the filter</li> <li>• Is the desired temperature setting too low</li> <li>• Is window or door opened</li> <li>• Is the louvre obstructed</li> <li>• Is the gas tube bent or cracked</li> <li>• Is the gas valve fully opened</li> <li>• Is there any obstruction within 1m in front of the heater</li> </ul>	<ul style="list-style-type: none"> <li>• Clean the filter</li> <li>• Set the desired temperature higher than the current temperature</li> <li>• Close the window or door</li> <li>• Remove the obstruction</li> <li>• Check the condition of the gas tube</li> <li>• Fully open the valve</li> <li>• Remove the obstruction</li> </ul>
Smell of gas	<ul style="list-style-type: none"> <li>• Is the gas tube connected firmly (Check if the gas escapes at the junction part)</li> </ul>	<ul style="list-style-type: none"> <li>• Immediately close the valve and ventilate the room and call for service</li> </ul>
“HH” mark on the temperature display lamp	<ul style="list-style-type: none"> <li>• Is there dust inside the filter</li> <li>• Is the louvre or air inlet obstructed</li> <li>• Is the gas connected properly</li> </ul>	<ul style="list-style-type: none"> <li>• Clean the filter</li> <li>• Remove the obstruction</li> <li>• Check the gas type on the name plate.</li> </ul>
“88”“88” mark on the temperature display lamp	<ul style="list-style-type: none"> <li>• Is the gas valve fully opened</li> <li>• Is there any air left in gas tube</li> </ul>	<ul style="list-style-type: none"> <li>• Open the valve fully</li> <li>• Repeat the run/stop manually and check the ignition operation</li> </ul>

# SPECIFICATIONS

Model	RHFE-1510F
DESCRIPTION	The Rinnai RHFE-1510F Forced Flue Fully Automatic Space Heater.
TYPE	Forced flue convection heater.
INPUT	17.4kW
GAS CONTROL	Rinnai electronic control. Rinnai solenoid valves.
AMBIENT(°C)	-5°C ~ 30°C
BURNER	Stainless steel, ribbon type.
GAS INLET	1/2 in BSP.
TEST POINT PRESSURE	G20 : 16.8mbar, G31 : 20.4mbar
FLUE	Forced flue (components supplied with heater).
FLUE TERMINATION	Supplied with heater.
IGNITION	Automatic flame sensing.
ELECTRICAL SUPPLY	230V, 50Hz. Replace only Rinnai part number.
FAN	Centrifugal 2 speed fan.

Rinnai is continually updating and improving products therefore specifications are subject to change without prior notice.



# SERVICE CONTACT POINT

Our service personnel are fully trained and equipped to give you the best service on your Rinnai appliance.

If you require service please ring the contact number on this page.

## **Rinnai** UK

9 Christleton Court  
Manor Park  
Runcorn  
WA7 1ST  
01928 531 870  
01928 531 880  
[www.rinnaiuk.com](http://www.rinnaiuk.com)

## Notes

**FORCED FLUE HEATER**  
**RHFE-1510F**  
**CUSTOMER OPERATING**  
**AND**  
**INSTALLATION INSTRUCTIONS**

**Rinnai**



Read the user's instructions before lighting the appliance.  
This appliance shall be installed in accordance with  
these Manufacturers Installation Instructions,  
Local Gas Fitting Regulations, any other relevant  
Statutory Regulation, and must be installed,  
serviced and removed by an authorised Person.