



Electro-Voice®

EQ-231

Stereo 31 Band 1/3 Octave Equalizer

OWNER'S OPERATION AND SERVICE INSTRUCTIONS

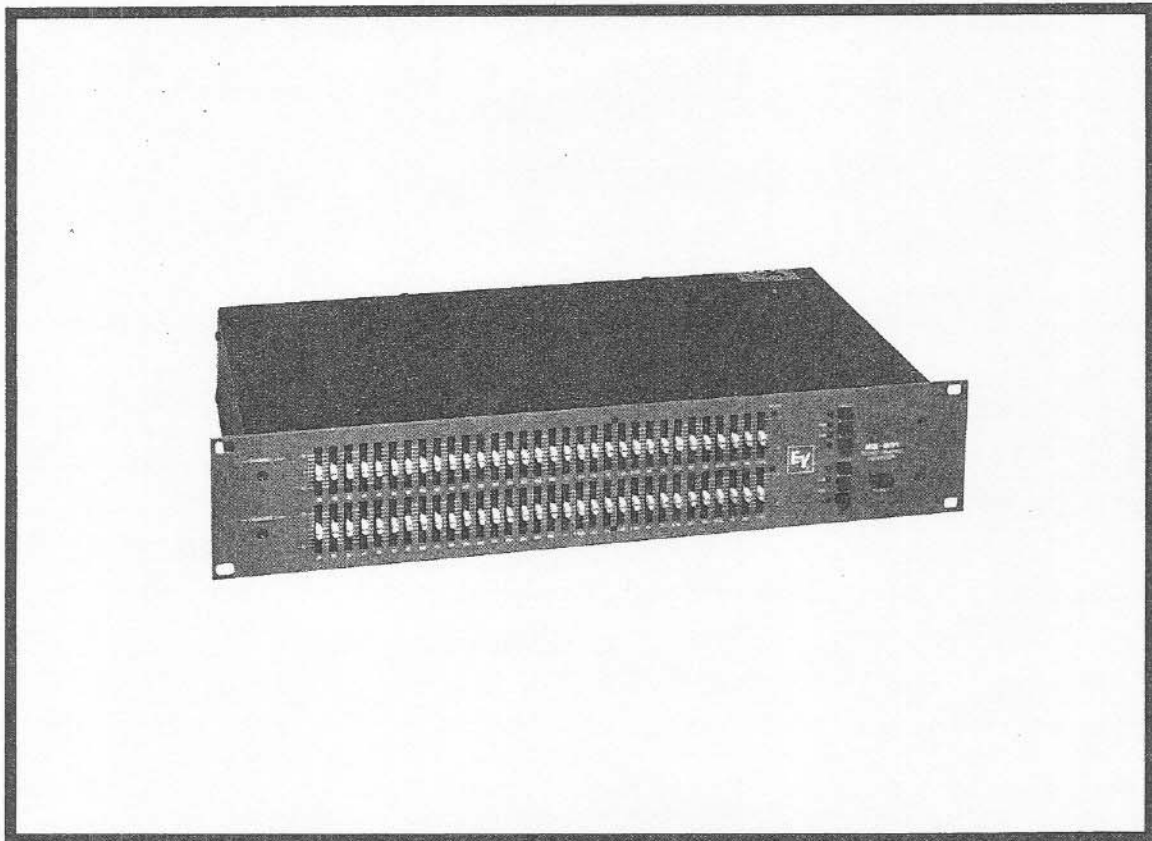

1 ELECTRICAL

1.1 115 Vac, 50/60 Hz Power Connections

The EQ-231 is provided with the primary of the power transformer selected for 115 Vac operation from the factory.

NOTE: Verify that the ac line voltage is in accordance with the selected voltage rating before connecting the equalizer to the ac line.

1.2 230 Vac, 50/60 Hz Power Connections

The EQ-231 may be powered from 230 Vac line voltages by removing the fuse holder from the power receptical and then pulling the fuse clip out, turning it 180 degrees and reinserting it, making sure 230 shows in the fuse holder window. Next remove the 500 ma. fuse and install the 315 ma. fuse (found in the bag marked European) and then place the holder back in the power receptical.

1.3 Fuse Replacement

If the fuse needs replacement, it must be replaced by one of the same type and rating for the power connections being used. See below:

500mA/250V SB (115 Vac line)
315mA/250V NB (230 Vac line)

2 INSTALLATION

2.1 Rack Mounting

The EQ-231 may be installed in a standard 19 inch equipment rack. It requires 3 1/2 inches of vertical rack space and mounting is accomplished by using the four rack mount screws provided.

2.2 Ventilation

The EQ-231 must be adequately ventilated to avoid excessive temperature rise. It should not be used in areas where the ambient temperature exceeds 50°C (122°F). To determine the ambient air temperature, operate the system in the rack until the temperature stabilizes. Measure the ambient air with a bulb-type thermometer held at the bottom of the upper-most unit. Do not let the thermometer touch the metal chassis because the chassis will be hotter than the ambient air. If the temperature exceeds 50°C (122°F), the equipment should be spaced at least 1 3/4 inches apart or a blower installed to provide sufficient air movement within the cabinet.

WARNING: Do not operate the equalizer within a completely closed, unventilated housing.

3 SIGNAL CONNECTIONS (Both Channels)

3.1 Input Connections

Balanced input connections may be made to either the XLR female connector or the balanced phone jack. For single-ended inputs, strap pins 1 and 3 on the XLR connector or when using the balanced phone jack, strap the ring to the sleeve. Refer to Figure 1 for typical input connections.

3.2 Output Connections

Output connections are made to either the XLR male connector or the single circuit phone jack. For balanced output use the XLR connector. For unbalanced output use the phone jack. Refer to Figure 2 for typical output connections.

4 OPERATION

4.1 Front and Rear Panel Controls

FRONT PANEL

- BOOST/CUT slider controls for frequency bands.
- PEAK. Peak indicator.
- LEVEL. Output level control.
- LO-CUT. Bass cut switch.
- EQ ON. Equalizer on/off switch.
- RANGE. Boost/Cut range switch.
- ON/OFF. Power switch.

REAR PANEL

- Electronically balanced inputs.
- Balanced/Unbalanced outputs.
- Ground-Lift-Switch.
- Fuse holder/ac line voltage selector.

4.2 BOOST/CUT Slider Adjustments

The primary tones of the bass drum, bass tuba, electric and acoustic bass guitar and the organ pedal clavier are affected mostly by the frequency bands 20 Hz through 100 Hz. In special cases the 63 Hz band can be used to filter out line hum (setting slider to max cut).

To modify lower vocals, drum fundamentals, upper bass, and lower bass instruments such as tuba and trombone use the frequency bands 125 Hz through 250 Hz. The 250 Hz band can be used for a slight boost, giving vocals added fullness where a degree of additional support is desired.

The frequency bands 315 Hz through 630 Hz affect the lower mid-range of musical material, such as the fundamental frequencies of voices, string and percussive instruments.

The frequency bands 800 Hz through 2 kHz and especially 1 kHz and 1.6 kHz bands enhance harmonics and fundamental frequencies of voices, strings, percussive, and keyboard instruments. These bands also accent the effects of flanging and phasing.

The 2.5 kHz through 6.3 kHz bands affect vocal fricatives, drums, and guitar. The use of these bands is highly dependent on the acoustical characteristics of the hall, its reverberation and sound absorption.

Cymbals and the synthesizer in particular will be markedly accentuated by boosts in the frequency bands 8 kHz through 20 kHz. By turning up the 8 kHz control, the presence of a singer's voice can, for example be reinforced. One possibility for reduction of noise in PA systems is to cut the 16 kHz and 20 kHz frequency range slightly.

4.3 PEAK Indicator

The PEAK indicator will light when the output level reaches a point 6dB below output clipping. The EQ-231 should be operated below this point.

4.4 LEVEL Control

The LEVEL control provides ± 6 dB or ± 12 dB of level control (from the detent position) only when all Boost/Cut sliders are in the detent position. The 6 and 12 dB ranges are determined by the RANGE switch.

4.5 LO-CUT Switch

When the LO-CUT switch is depressed the red LED will light, indicating the frequency response below 43 Hz will be rolled off at 18dB per octave.

4.6 EQ ON Switch

When the EQ ON switch is depressed the red LED will light, indicating the EQ is activated. In the EQ OFF position, it causes the equalizer to be bypassed.

4.7 RANGE Switch

When in the 6dB position (red LED on) it will allow the sliders to adjust the boost and cut by approximately ± 6 dB. The 12dB position (green LED on) will likewise allow approximately a ± 12 dB boost and cut adjustment.

4.8 POWER Switch

Power is turned on or off by this switch.

4.9 Ground-Lift-Switch

Slide switch for eliminating hum from ground loops. Disconnects circuit chassis. If several units are installed in one rack, the switch should be set to "GROUNDED" on only one of the units.

5 IN CASE OF PROBLEMS

Please check the following items:

1. Verify that the EQ-231 is properly connected to an ac power source and that the source is active.
2. Verify that the input connections are properly made. Refer to Figure 1.
3. Verify that the output connections are properly

made. Refer to Figure 2.

4. Check the input and output cables for proper wiring and continuity.
5. Check the signal source and the load.

Check that the EQ-ON switch is in the ON position.

Installation and Operating Instructions for the EQ-231 Stereo 31 Band 1/3 Octave Equalizer

6 SPECIFICATIONS (Both Channels)

Filter Type:	Variable Q Active filter set.	Controls:	<ul style="list-style-type: none">● 31 center detent slide controls at 1/3 octave center frequencies from 20 Hz to 20 kHz, with selectable $\pm 6\text{dB}$ or $\pm 12\text{dB}$ boost/cut.● LEVEL control with center detent● LO-CUT select switch● RANGE $\pm 6\text{dB}$ or $\pm 12\text{dB}$ select switch● EQ-ON Equalizer ON select switch● AC Power switch● Ground-Lift-Switch
Number of Bands:	31 bands at ISO center frequencies: 20 Hz, 25 Hz, 32 Hz, 40 Hz, 50 Hz, 63 Hz, 80 Hz, 100 Hz, 125 Hz, 160 Hz, 200 Hz, 250 Hz, 315 Hz, 400 Hz, 500 Hz, 630 Hz, 800 Hz, 1 kHz, 1.25 kHz, 1.6 kHz, 2 kHz, 2.5 kHz, 3.15 kHz, 4 kHz, 5 kHz, 6.3 kHz, 8 kHz, 10 kHz, 12.5 kHz, 16 kHz, 20 kHz	Connectors:	
Input: (Ref. 0dBu = 0.775V _{rms})		Input:	Female XLR (balanced) 1/4" Phone jack (balanced)
Type:	Electronically balanced	Output:	Male XLR (balanced) 1/4" Phone jack (unbalanced)
Impedance:	44K Ω balanced 22K Ω unbalanced	AC Power:	115, 230 Vac 50/60Hz 18 Watts
Normal level:	0dBu(0.775V _{rms})	Operating Temperature	
Maximum level:	+20dBu(7.75V _{rms})	Range:	Up to 50°C (122°F)
Output: (Ref. 0dBu = 0.775V _{rms})		Dimensions:	88 mm (3.46 in.) high; 483 mm (19.0 in.) wide; 235 mm (9.24 in.) deep
Type:	Electronically balanced	Net Weight:	4.0 kg (8.8 lbs)
Impedance:	120 Ω balanced 60 Ω unbalanced	Enclosure:	Rack Mount Chassis (1 3/4 inch rack space)
Maximum level:	20dBu	Accessories:	<ul style="list-style-type: none">● Power cord● One pkg. of mounting screws● One pkg. of rubber feet● One decal and fuse for 230 Vac line operation● One EQ-231 Installation and Operating Instructions
Load Impedance:	600 ohms or higher	Operating Gain:	0dB
Peak Indicator:	Red LED +14dBu(6dB before clipping)	Available Gain:	$\pm 6\text{dB}$ or $\pm 12\text{dB}$
Frequency Response: (Ref. 1 kHz = 0dBu)	Across 600 Ω Load 20 Hz-20 kHz $\pm 1\text{dB}$	High-Pass Filter:	Switch selectable with Cutoff below 43 Hz and a slope of 18dB per octave.
THD:	<0.01% from 20 kHz to 20 kHz, all bands at 0 dB	Noise:	<-90dBm A-wtd (500 kHz BW), all bands at 0dB

Electro-Voice continually strives to improve its products and their specifications. Therefore, all specifications are subject to change without notice.

ELECTRO-VOICE UNIFORM WARRANTY STATEMENT

Electro-Voice products are guaranteed against malfunction due to defects in materials or workmanship for a specified period, as noted in the individual product-line statement(s) below, or in the individual product data sheet or owner's manual, beginning with the date of original purchase. If such malfunctions occurs during the specified period, the product will be repaired or replaced (at our option) without charge. The product will be returned to the customer prepaid. **Exclusions and Limitations:** The Limited Warranty does not apply to: (a) exterior finish or appearance; (b) certain specific items described in the individual product-line statement(s) below, or in the individual product data sheet or owner's manual; (c) malfunction resulting from use or operation of the product other than as specified in the product data sheet or owner's manual; (d) malfunction resulting from misuse or abuse of the product; (e) malfunction occurring at any time after repairs have been made to the product by anyone other than Electro-Voice or any of its authorized service representatives. **Obtaining Warranty Service:** To obtain warranty service, a customer must deliver the product, prepaid, to Electro-Voice or any of its authorized service representatives together with proof of purchase of the product in the form of a bill of sale or receipted invoice. A list of authorized service representatives is available from Electro-Voice at 600 Cecil Street, Buchanan, MI 49107 (616/695-6831) and/or Electro-Voice West at 8234 Doe Avenue, Visalia, CA 93291 (209/651-7777). **Incidental and Consequential Damages Excluded:** Product repair or replacement and return to the customer are only remedies provided to the customer. Electro-Voice shall not be liable for any incidental or consequential damages including, without limitation, injury to persons or property or loss of use. Some states do not allow the exclusion or limitation of incidental or consequential damages so the above limitation or exclusion may not apply to you. **Other Rights:** This warranty gives you specific legal rights, and you may also have rights which vary from state to state.

Electro-Voice Electronics are guaranteed against malfunction due to defects in materials or workmanship for a period of three (3) years from date of original purchase. Additional details are included in the Uniform Limited Warranty statement.



EQ-231

STEREO

31 BAND 1/3 OCTAVE EQUALIZER

SERVICE INSTRUCTIONS

CAUTION

No user serviceable parts inside. Hazardous voltage and currents may be encountered within the chassis. The service information contained within this document is for use only by ELECTRO-VOICE authorized warranty stations and qualified service personnel. To avoid electric shock, DO NOT perform any servicing other than that contained in the Operating Instructions unless you are qualified to do so. Refer all servicing to qualified service personnel.

9 SERVICE INFORMATION

CAUTION: *No user serviceable parts inside. Hazardous voltages and currents may be encountered within the chassis. The service information contained within this document is for use only by ELECTRO-VOICE authorized warranty stations and qualified service personnel. To avoid electric shock DO NOT perform any servicing other than that contained in the Operating Instructions unless you are qualified to do so. Otherwise, refer all servicing to qualified service personnel.*

NOTE: *Modifications to ELECTRO-VOICE products are not recommended. Such modifications shall be at the sole expense of the person(s) or company responsible, and any damage resulting there from shall not be covered under warranty or otherwise.*

Figure 6 and figure 7 is the EQ-231 schematic. There are no internal adjustments which can be made.

9.1 Parts Ordering

To order replacement parts, look up the ordering number from the parts list and write or call:

Electro-Voice
600 Cecil Street
Buchanan, MI 49107 U.S.A.
(616) 695-6831
FAX(616) 695-1304
TWX: 810-270-3135

Electro-Voice West
8234 Doe Avenue
Visalia, CA 93291 U.S.A.
(209) 651-7777
FAX(209) 651-0164
TLX 172119

9.2 Factory Service

If factory service is required, ship the unit prepaid to:

Electro-Voice
600 Cecil Street
Buchanan, MI 49107 U.S.A

Electro-Voice West
8234 Doe Avenue
Visalia, CA 93291 U.S.A.

Enclose a note describing the problem in as much detail as possible. Include other helpful information such as test conditions, where used, how used, etc.

9.3 Technical Assistance

For applications assistance/technical information, write or call:

Electro-Voice
600 Cecil Street
Buchanan, MI 49107 U.S.A.
(616) 695-6831
FAX(616) 695-1304
TWX: 810-270-3135

Electro-Voice West
8234 Doe Avenue
Visalia, CA 93291 U.S.A.
(209) 651-7777
FAX(209) 651-0164
TLX 172119

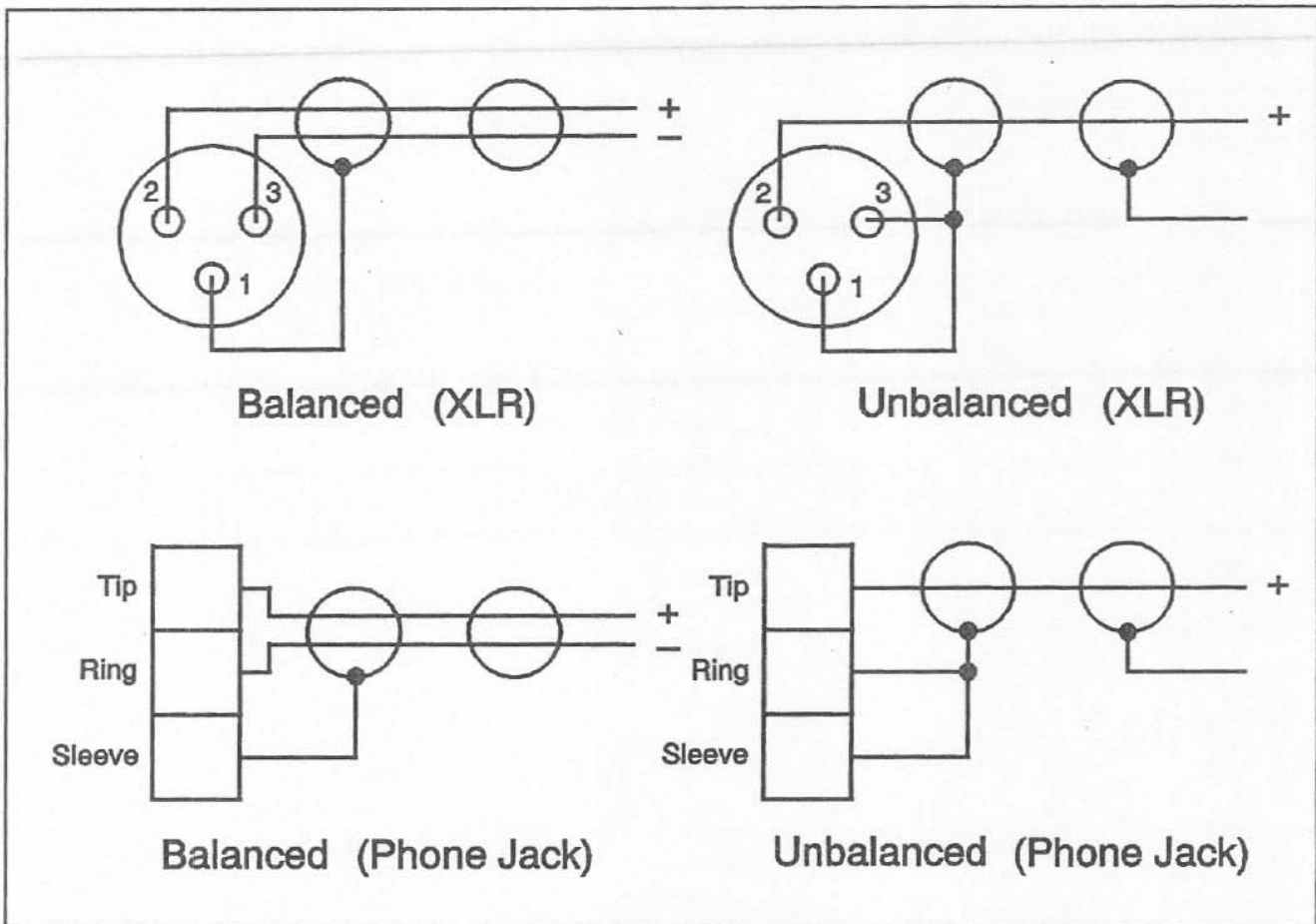

Figure 1 Input Connections

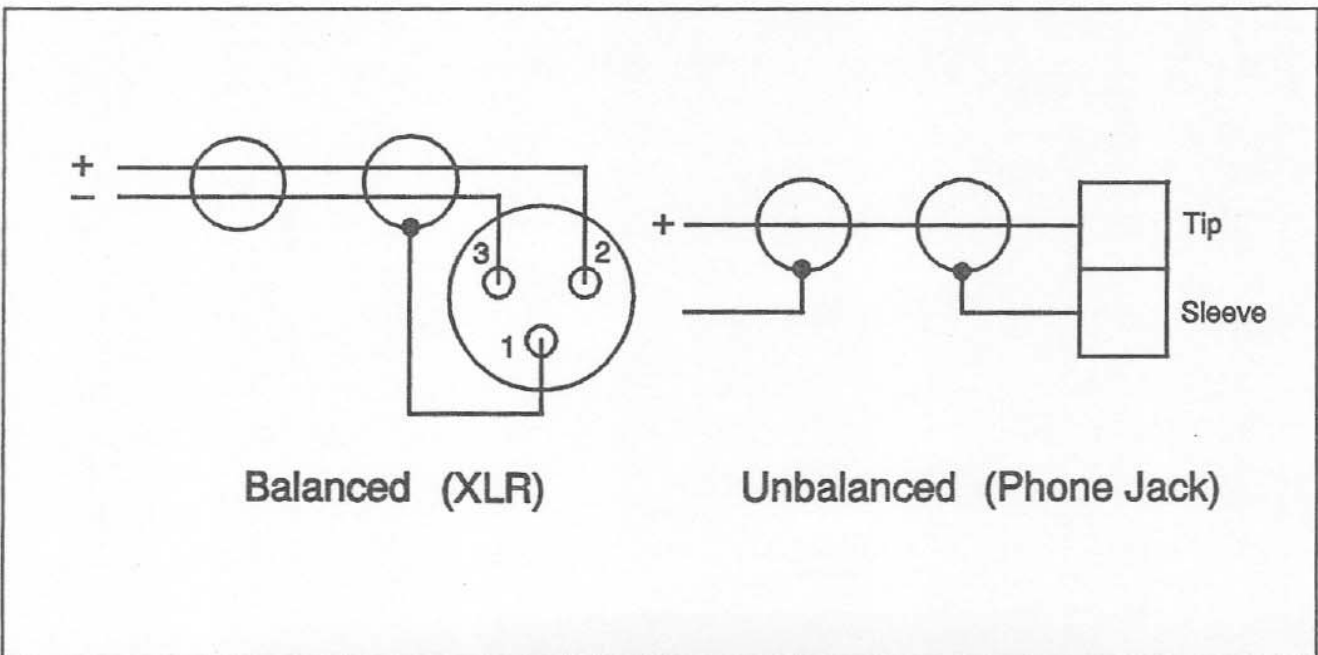
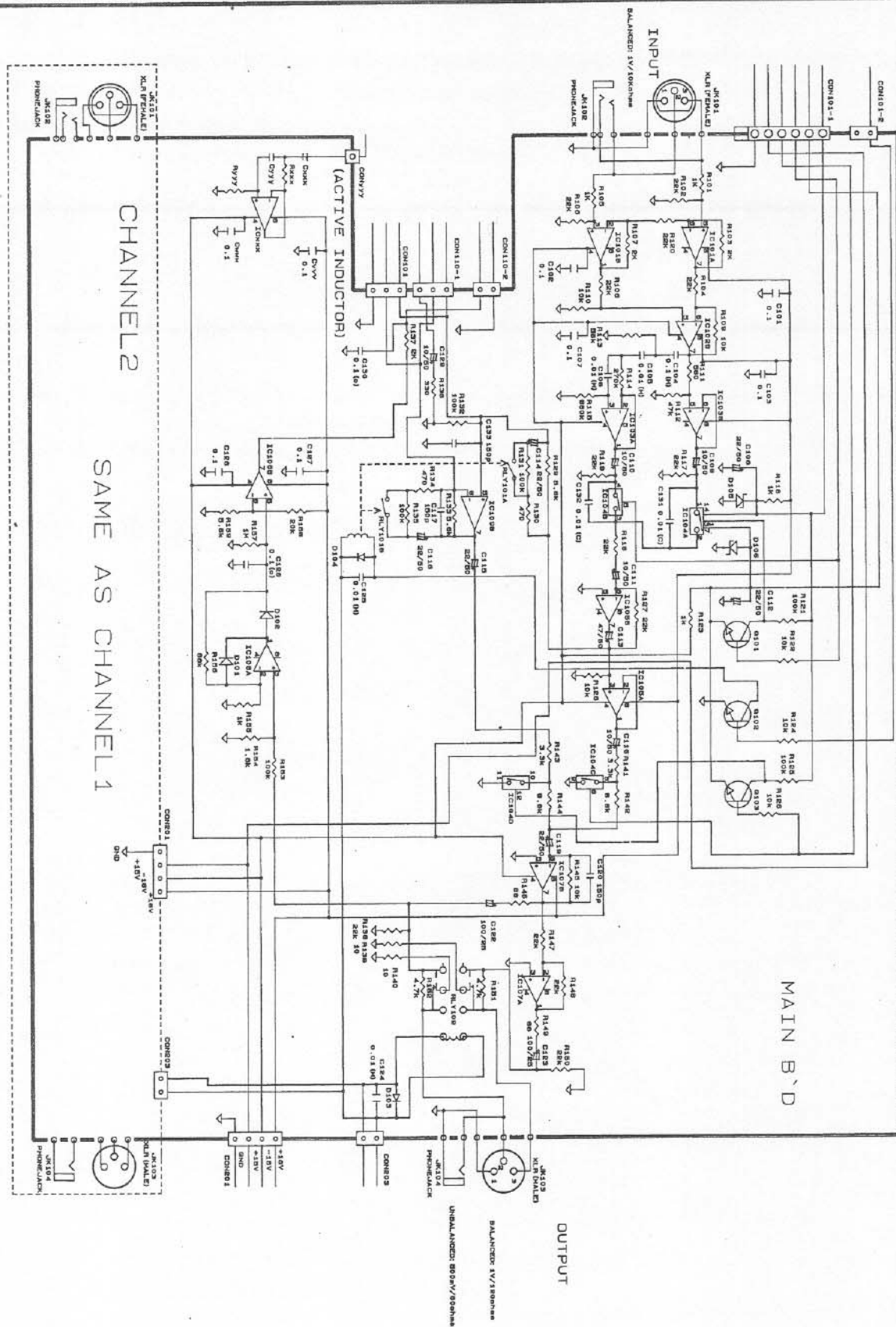

Figure 2 Output Connections

Installation and Operating Instructions for the EQ-231 Stereo 31 Band 1/3 Octave Equalizer



Schematic of EQ-231 Sheet 1 of 4

Installation and Operating Instructions for the EQ-231 Stereo 31 Band 1/3 Octave Equalizer

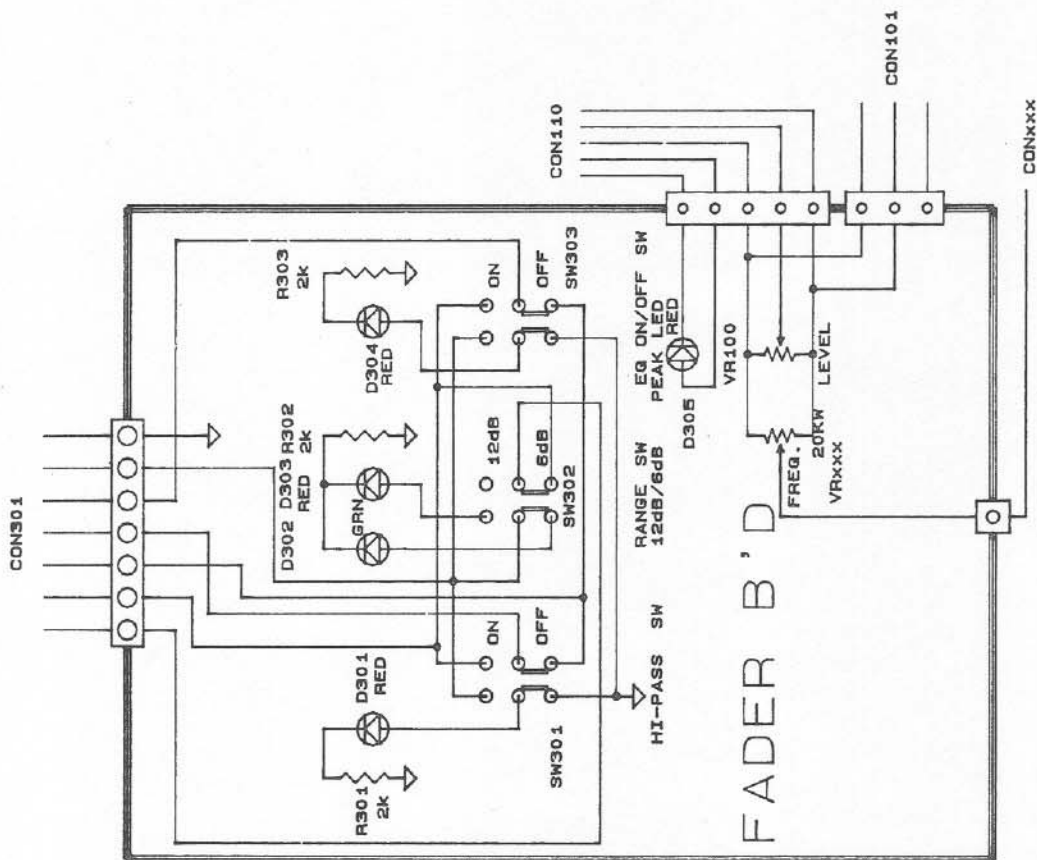
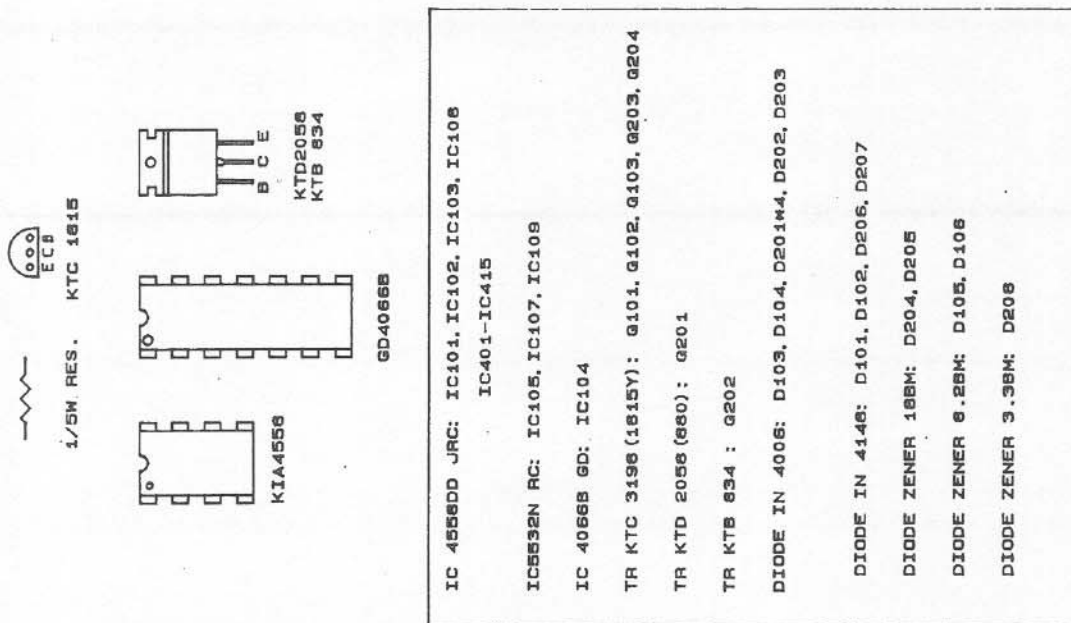

Schematic of EQ-231 Sheet 2 of 4

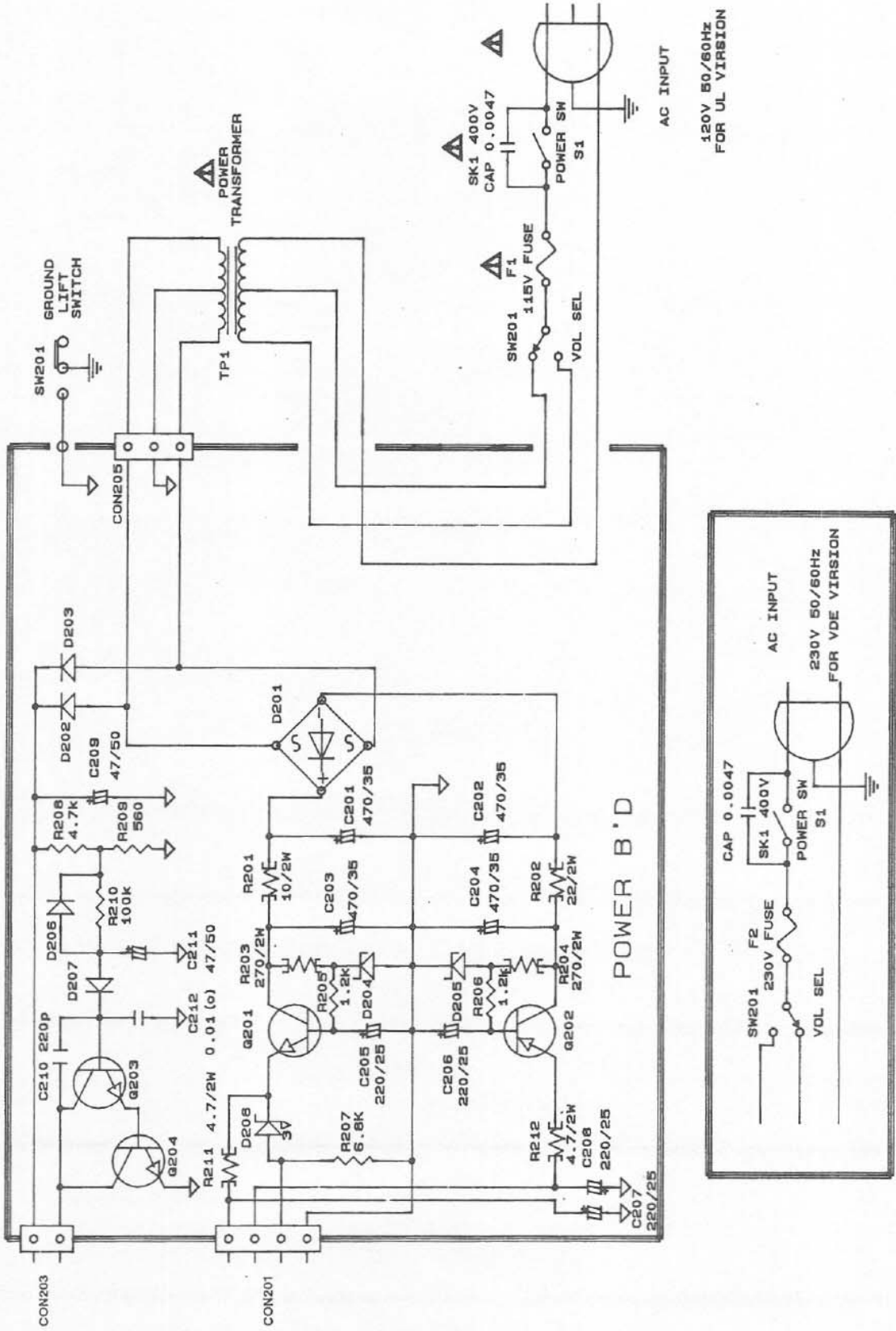

Schematic of EQ-231 Sheet 3 of 4

Installation and Operating Instructions for the EQ-231 Stereo 31 Band 1/3 Octave Equalizer

Parts Value for Active Inductor

Freq.	VRxxx	ICxxx	Cxxx	Cyyy	Cvyy	Cwww	Rxxx	Ryyy	CONxxx	CONyyy
20Hz	VR101	IC401b	C701: 2.2u	C702: 0.47u	C764	C763	R701: 309	R702: 196k	CON102	CON102
25Hz	VR102	IC401b	C703: 2.2u	C704: 0.47u			R703: 316	R704: 124k	CON102	CON102
32Hz	VR103	IC402b	C705: 2.2u	C706: 0.47u			R705: 301	R706: 78.7k	CON102	CON102
40Hz	VR104	IC402b	C707: 1.5u	C708: 0.33u			R707: 280	R708: 115k	CON102	CON102
50Hz	VR105	IC403b	C709: 1u	C710: 0.22u			R709: 287	R710: 158k	CON103	CON103
63Hz	VR106	IC403b	C711: 1u	C712: 0.15u			R711: 294	R712: 143k	CON103	CON103
80Hz	VR107	IC406b	C729: 0.82u	C730: 0.15u			R729: 287	R730: 110k	CON103	CON103
100Hz	VR108	IC406b	C731: 0.66u	C732: 0.1u			R731: 294	R732: 127k	CON103	CON103
125Hz	VR109	IC404b	C713: 0.47u	C714: 0.066u			R713: 287	R714: 178k	CON104	CON104
160Hz	VR110	IC404b	C715: 0.47u	C716: 0.066u			R715: 294	R716: 105k	CON104	CON104
200Hz	VR111	IC409b	C727: 0.33u	C728: 0.047u			R725: 287	R726: 105k	CON104	CON104
250Hz	VR112	IC409b	C725: 0.27u	C726: 0.066u			R727: 287	R728: 120k	CON104	CON104
315Hz	VR113	IC405b	C717: 0.22u	C718: 0.047u			R717: 242	R718: 102k	CON105	CON105
400Hz	VR114	IC405b	C719: 0.18u	C720: 0.033u			R719: 255	R720: 105k	CON105	CON105
500Hz	VR115	IC410b	C723: 0.15u	C724: 0.022u			R723: 280	R724: 110k	CON105	CON105

Freq.	VRxxx	ICxxx	Cxxx	Cyyy	Cvyy	Cwww	Rxxx	Ryyy	CONxxx; PINxxx
630Hz	VR116	IC410b	C721: 0.1u	C722: 0.022u			R721: 243	R722: 120k	CON105 CON105
800Hz	VR117	IC406b	C737: 0.1u	C738: 0.015u	C765	C767	R737: 255	R738: 102k	CON106 CON106
1K	VR118	IC406b	C739: 0.066u	C740: 0.01u			R739: 255	R740: 143k	CON106 CON106
1.25K	VR119	IC411b	C743: 0.066u	C744: 0.0082u			R743: 261	R744: 110k	CON106 CON106
1.6K	VR120	IC411b	C741: 0.047u	C742: 0.0066u			R741: 255	R742: 120k	CON106 CON106
2K	VR121	IC407b	C733: 0.033u	C734: 0.0056u			R733: 242	R734: 143k	CON107 CON107
2.5K	VR122	IC407b	C735: 0.033u	C736: 0.0047u			R735: 249	R736: 105k	CON107 CON107
3.15K	VR123	IC412b	C747: 0.022u	C748: 0.0033u		C766	R747: 232	R748: 127k	CON107 CON107
4K	VR124	IC412b	C745: 0.022u	C746: 0.0033u			R745: 255	R746: 82k	CON107 CON107
5K	VR125	IC413b	C749: 0.015u	C750: 0.0027u			R749: 243	R750: 102k	CON108 CON108
6.3K	VR126	IC413b	C751: 0.012u	C752: 0.0022u			R751: 220	R752: 110k	CON108 CON108
8K	VR127	IC414b	C753: 0.0082u	C754: 0.0018u			R753: 205	R754: 130k	CON108 CON108
10K	VR128	IC414b	C755: 0.0066u	C756: 0.0015u			R755: 215	R756: 115k	CON108 CON108
12.5K	VR129	IC102b	C761: 0.0056u	C762: 0.0015u			R761: 237	R762: 82k	CON109 CON109
16K	VR130	IC415b	C757: 0.0047u	C758: 0.001u			R757: 294	R758: 71.5k	CON109 CON109
20K	VR131	IC415b	C759: 0.0033u	C760: 820p			R759: 261	R760: 66.7k	CON109 CON109

Schematic of EQ-231 Sheet 4 of 4

Component Parts Listing for the EQ-231

Reference Designator	Ordering Number	Name and Description
C101, 102, 103, 107, 126, 127, 128, 130, 763, 764, 765, 766, 767	15-02-037884	Capacitor, .1 μ F, +80-20%, 50V, Axial Ceramic
C104, 721, 732, 737	15-06-037885	Capacitor, .1 μ F, 5%, 50V, Mylar
C105, 106, 124, 125, 740,	15-06-037208I	Capacitor, .01 μ F, 5%, 100V, Mylar
C108, 112, 114, 115, 116, 119	15-01-037886	Capacitor, 22 μ F, 50V Elect.
C109, 110, 111, 118, 129	15-01-037222	Capacitor, 10 μ F, 50V
C113	15-01-026641	Capacitor, 47 μ F, 50V
C117, 120, 133	15-02-037887	Capacitor, 150 PF, 10%, 50V, Axial Ceramic
C122, 123	15-01-038331	Capacitor, 100 μ F, 25V Elect.
C131, 132, 212	15-02-038072	Capacitor, .01 μ F, +80-20%, 25V, Axial Ceramic
C701, 703, 705	15-01-037888	Capacitor, 2.2 μ F, 50V Elect.
C702, 704, 706, 713, 715	15-06-037889	Capacitor, .47 μ F, 5%, 50V, Mylar
C707	15-01-037890	Capacitor, 1.5 μ F, 50v Elect.
C708, 727	15-06-037891	Capacitor, .33 μ F, 5%, 50V, Mylar
C709, 711	15-06-037892	Capacitor, 1 μ F, 5%, 50V, Mylar
C710, 717	15-06-037893	Capacitor, .22 μ F, 5%, 50V, Mylar
C712, 723, 730	15-06-037894	Capacitor, .15 μ F, 5%, 50V, Mylar
C714, 716, 728, 739, 743	15-06-037895	Capacitor, .068 μ F, 5%, 100V, Mylar
C718, 726, 741	15-06-037896	Capacitor, .047 μ F, 5%, 100V, Mylar
C719	15-06-037897	Capacitor, .18 μ F, 5%, 50V, Mylar
C720, 733, 735	15-06-037898	Capacitor, .033 μ F, 5%, 100V, Mylar
C722, 724, 745, 747	15-06-037211	Capacitor, .022 μ F, 5%, 100V, Mylar
C725	15-06-037899	Capacitor, .27 μ F, 5%, 50V, Mylar
C729	15-06-037900	Capacitor, .82 μ F, 5%, 50V, Mylar
C731	15-06-037901	Capacitor, .68 μ F, 5%, 50V, Mylar
C734, 761	15-06-037194	Capacitor, .0056 μ F, 5%, 100V, Mylar
C736, 757	15-06-037902	Capacitor, .0047 μ F, 5%, 100V, Mylar
C738, 749	15-06-037903	Capacitor, .015 μ F, 5%, 100V, Mylar
C742, 755	15-06-037207	Capacitor, .0068 μ F, 5%, 100V, Mylar
C744, 753	15-06-037904	Capacitor, .0082 μ F, 5%, 100V, Mylar
C746, 759	15-06-037140	Capacitor, .0033 μ F, 5%, 100V, Mylar
C748	15-06-037905	Capacitor, .0039 μ F, 5%, 100V, Mylar
C750	15-06-037906	Capacitor, .0027 μ F, 5%, 100V, Mylar
C751	15-06-037209	Capacitor, .012 μ F, 5%, 100V, Mylar
C752	15-06-037192	Capacitor, .0022 μ F, 5%, 100V, Mylar
C754	15-06-037139	Capacitor, .0018 μ F, 5%, 100V, Mylar
C756, 762	15-06-037190	Capacitor, .0015 μ F, 5%, 100V, Mylar
C758	15-06-037907	Capacitor, .001 μ F, 5%, 100v, Mylar
C760	15-02-037908	Capacitor, 820 PF, 10%, 50V, Axial Ceramic
C201, 202, 203, 204	15-01-037909	Capacitor, 470 μ F, 35V Elect.
C205, 206, 207, 208	15-01-037910	Capacitor, 220 μ F, 25V Elect.
C209, 211	15-01-037144	Capacitor, 47 μ F, 50V Elect.
C210	15-02-037911	Capacitor, 220 PF, 10%, 50V, Axial Ceramic
D101, 102, 206, 207	48-01-122601	Diode, 1N4148
D103, 104, 201-1, 201-2, 201-3, 201-4	48-01-027300	Diode, 1N4006
D105, 106	48-01-037912	Diode Zener, 8.2V, 5%, .5W
D204, 205	48-01-113386	Diode Zener, 18V, 5%, .5W

Installation and Operating Instructions for the EQ-231 Stereo 31 Band 1/3 Octave Equalizer

Reference Designator	Ordering Number	Name and Description
D208	48-01-037913	Diode Zener, 3.3V, 5%, .5W
D301, 303, 304, 305	39-01-037914	LED, Red, KLR124
D302	39-01-037915	LED, Green, EL 204GD
Q101, 102, 103, 203, 204	48-03-026624	Transistor, NPN, KTC 1815Y
Q201	48-03-037916	Transistor, NPN, KTD 2058Y
Q202	48-03-037917	Transistor, PNP, 834Y
R101, 105, 116, 123, 155	47-01-037121I	Resistor, 1 k Ω , \pm 5%, 1/5 W, C.F.
R102, 104, 106, 108, 117, 118, 119, 120, 127, 138, 147, 148, 150	47-01-037919	Resistor, 22 k Ω , \pm 5%, 1/5 W, C.F.
R103, 107, 137, 301, 302, 303	47-01-037920	Resistor, 2 k Ω , \pm 5%, 1/5 W, C.F.
R109, 110, 122, 124, 126, 128, 145	47-01-037169I	Resistor, 10 k Ω , \pm 5%, 1/5 W, C.F.
R111, 209	47-01-037423	Resistor, 560 Ω , \pm 5%, 1/5 W, C.F.
R112	47-01-037258	Resistor, 47 k Ω , \pm 5%, 1/5 W, C.F.
R113	47-01-037175	Resistor, 56 k Ω , \pm 5%, 1/5 W, C.F.
R114	47-01-037921	Resistor, 270 k Ω , \pm 5%, 1/5 W, C.F.
R115	47-01-037365	Resistor, 680 k Ω , \pm 5%, 1/5 W, C.F.
R121, 125, 131, 132, 135, 153, 210	47-01-037126	Resistor, 100 k Ω , \pm 5%, 1/5 W, C.F.
R129, 133, 159	47-01-037255	Resistor, 5.6 k Ω , \pm 5%, 1/5 W, C.F.
R130, 134	47-01-037210	Resistor, 470 Ω , \pm 5%, 1/5 W, C.F.
R136	47-01-037159	Resistor, 330 Ω , \pm 5%, 1/5 W, C.F.
R139, 140	47-01-102030	Resistor, 10 Ω , \pm 5%, 1/5 W, C.F.
R141, 143	47-01-037254	Resistor, 3.3 k Ω , \pm 5%, 1/5 W, C.F.
R142, 144, 207	47-01-037922	Resistor, 6.8 k Ω , \pm 5%, 1/5 W, C.F.
R146, 149	47-01-037422	Resistor, 68 Ω , \pm 5%, 1/5 W, C.F.
R151, 152, 208	47-01-037166	Resistor, 4.7 k Ω , \pm 5%, 1/5 W, C.F.
R154	47-01-037923	Resistor, 1.8 k Ω , \pm 5%, 1/5 W, C.F.
R156	47-01-037259	Resistor, 68 k Ω , \pm 5%, 1/5 W, C.F.
R157	47-01-108491	Resistor, 1 M Ω , \pm 5%, 1/5 W, C.F.
R158	47-01-037172	Resistor, 20 k Ω , \pm 5%, 1/5 W, C.F.
R701	47-03-038342	Resistor, 309 Ω , \pm 1%, 1/5 W, C.F.
R702	47-03-037925	Resistor, 196 k Ω , \pm 1%, 1/5 W, C.F.
R703	47-03-038341I	Resistor, 316 Ω , \pm 1%, 1/5 W, C.F.
R704	47-03-037926	Resistor, 124 k Ω , \pm 1%, 1/5 W, C.F.
R705	47-03-038340	Resistor, 301 Ω , \pm 1%, 1/5 W, C.F.
R706	47-03-037928	Resistor, 78.7 k Ω , \pm 1%, 1/5 W, C.F.
R707, 723	47-03-038339	Resistor, 280 Ω , \pm 1%, 1/5 W, C.F.
R708, 756	47-03-037930	Resistor, 115 k Ω , \pm 1%, 1/5 W, C.F.
R709, 713, 729	47-03-037927	Resistor, 287 Ω , \pm 1%, 1/5 W, C.F.
R710	47-03-037931	Resistor, 158 k Ω , \pm 1%, 1/5 W, C.F.
R711, 715, 731, 757	47-03-037932	Resistor, 294 Ω , \pm 1%, 1/5 W, C.F.
R712, 734, 740	47-03-037933	Resistor, 143 k Ω , \pm 1%, 1/5 W, C.F.
R714	47-03-037935	Resistor, 178 k Ω , \pm 1%, 1/5 W, C.F.
R716, 720, 728, 736	47-03-037198	Resistor, 105 k Ω , \pm 1%, 1/5 W, C.F.
R717, 733	47-03-037936	Resistor, 242 Ω , \pm 1%, 1/5 W, C.F.
R718, 738, 750	47-03-123017	Resistor, 102 k Ω , \pm 1%, 1/5 W, C.F.

Installation and Operating Instructions for the EQ-231 Stereo 31 Band 1/3 Octave Equalizer

Reference Designator	Ordering Number	Name and Description
R719, 737, 739, 741, 745	47-03-038337	Resistor, 255 Ω , $\pm 1\%$, 1/5 W, C.F.
R721, 749	47-03-038335	Resistor, 243 Ω , $\pm 1\%$, 1/5 W, C.F.
R722, 726, 742	47-03-037938	Resistor, 120 k Ω , $\pm 1\%$, 1/5 W, C.F.
R724, 730, 744, 752	47-03-121457	Resistor, 110 k Ω , $\pm 1\%$, 1/5 W, C.F.
R725, 727	47-03-038338	Resistor, 267 Ω , $\pm 1\%$, 1/5 W, C.F.
R732, 748	47-03-037940	Resistor, 127 k Ω , $\pm 1\%$, 1/5 W, C.F.
R735	47-03-038336	Resistor, 249 Ω , $\pm 1\%$, 1/5 W, C.F.
R743, 759	47-03-037976	Resistor, 261 Ω , $\pm 1\%$, 1/5 W, C.F.
R746, 762	47-03-037941	Resistor, 82 k Ω , $\pm 1\%$, 1/5 W, C.F.
R747	47-03-037937	Resistor, 232 Ω , $\pm 1\%$, 1/5 W, C.F.
R751	47-03-037943	Resistor, 220 Ω , $\pm 1\%$, 1/5 W, C.F.
R753	47-03-038332	Resistor, 205 Ω , $\pm 1\%$, 1/5 W, C.F.
R754	47-03-037945	Resistor, 130 k Ω , $\pm 1\%$, 1/5 W, C.F.
R755	47-03-038333	Resistor, 215 Ω , $\pm 1\%$, 1/5 W, C.F.
R758	47-03-037947	Resistor, 71.5 k Ω , $\pm 1\%$, 1/5 W, C.F.
R760	47-03-037948	Resistor, 88.7 k Ω , $\pm 1\%$, 1/5 W, C.F.
R761	47-03-038334	Resistor, 237 Ω , $\pm 1\%$, 1/5 W, C.F.
R201	47-01-037949	Resistor, 10 Ω , $\pm 5\%$, 2 W, M.O.
R202	47-01-037950	Resistor, 22 Ω , $\pm 5\%$, 2 W, M.O.
R203, 204	47-01-037951	Resistor, 270 Ω , $\pm 5\%$, 2 W, M.O.
R205, 206	47-01-037371	Resistor, 1.2 k Ω , $\pm 5\%$, 1/5 W, C.F.
R211, 212	47-01-038444	Resistor, 4.7 Ω , $\pm 5\%$, 2 W, M.O.
RLY101, 102	45-01-037394	Relay, RY24W
SK1	15-02-037953	Capacitor, .0047 μ F, 400V (Spark Killer)
SW1	51-02-037954	Switch, Power
SW201	51-02-037955	Switch, Slide, S.P.D.T.
SW301, 302, 303	51-02-037956	Switch, Push, 122SC
TP1	56-08-037957	Transformer, Power
VR100-VR131	47-06-037958	Potentiometer, Slider, 20 K Ω , RS2011106-20KW
F1	51-04-038446	Fuse, 0.5A/250V SB, 20 MM, UL/CSA
F2	51-04-038357	Fuse, 0.315A/250V NB, 20 MM, UL/CSA
AI1	21-02-037961	Receptacle, AC Power
AC1	60-06-124962	Cable, Power, 18GA 3 Cond. 120V
JACK101	21-01-037962	Jack, XLR (Female)
JACK102	21-01-037963	Jack, Phone
JACK103	21-01-037964	Jack, XLR (Male)
JACK104	21-01-037965	Jack, Phone (Mic) AM-8001
IC101, 102, 103, 108, 401-415	17-01-038348	Circuit, Integrated, 4558DD
IC105, 107, 109	17-01-038349	Circuit, Integrated, 5532N
IC104	17-01-038347	Circuit, Integrated, 4066B
	24-04-038353	Knob, (used on slider pots)
	24-04-038354	Knob, (used on SW301, 302, 303)
	24-04-038355	Knob, (used on SW1)