

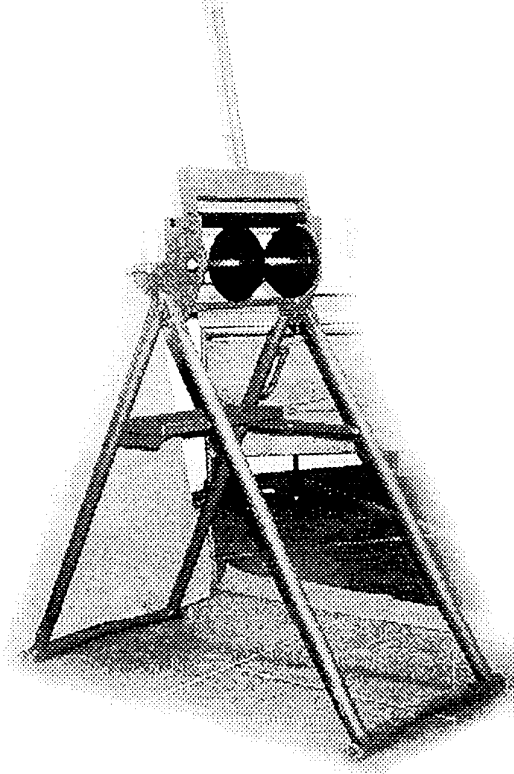

# CABLE TRAY BENDER AND VISE

## Model 43352

### ASSEMBLY AND OPERATING INSTRUCTIONS



3491 Mission Oaks Blvd., Camarillo, CA 93011  
Visit our Web site at <http://www.harborfreight.com>

Copyright © 2000 by Harbor Freight Tools. All rights reserved. No portion of this manual or any artwork contained herein may be reproduced in any shape or form without the express written consent of Harbor Freight Tools.

For technical questions please call 1-800-444-3353

## SPECIFICATIONS

ITEM	DESCRIPTION
Construction	1.263" Diameter Steel Tubing Frame 0.312" Steel Plate 1.116" Diameter Steel Tubing Handle 0.707" Diameter Steel Tubing Support Cast Aluminum Vise
Overall Dimensions	40" H x 20" W x 35-1/2" D
Tool Tray Dimensions	1-1/4" H x 15-1/2" W x 5-1/8" D
Net Weight	54 Lbs.
Maximum Metal Plate Capacity	13-3/4" Wide x 1/8" Thick
Minimum Diameter Capacity	2"
Maximum Length Capacity	12"
Assembly	Pre-Assembled

## SAVE THIS MANUAL

You will need the manual for the safety warnings and precautions, assembly instructions, operating and maintenance procedures, parts list and diagram. Keep your invoice with this manual. Write the invoice number on the inside of the front cover. Keep the manual and invoice in a safe and dry place for future reference.

## SAFETY WARNINGS AND PRECAUTIONS

1. **KEEP PRODUCT USAGE AREA CLEAN.** Cluttered areas invite injuries.
2. **KEEP CHILDREN AWAY FROM PRODUCT USAGE AREA.** Do not allow children to handle this product.
3. **DO NOT USE THE CABLE TRAY BENDER AND VISE IF UNDER THE INFLUENCE OF ALCOHOL OR DRUGS.** Read warning labels on prescriptions to determine if your judgement or reflexes are impaired while taking drugs. If there is any doubt, do not attempt to use this product.
4. **USE EYE PROTECTION.** Wear ANSI approved safety impact goggles. Goggles are available from Harbor Freight Tools.
5. **DRESS SAFELY.** Protective gloves and non-skid footwear or safety shoes should be used when working with the Cable Tray Bender and Vise. Do not wear loose clothing or jewelry as they can become caught in moving parts. Wear a protective hair covering to prevent long hair from becoming caught in the Cable Tray Bender and Vise.

6. **DO NOT OVERREACH.** Keep proper footing and balance at all times.
7. **STAY ALERT.** Watch what you are doing at all times. Use common sense. Do not operate the Cable Tray Bender and Vise when you are tired or distracted from the job at hand.
8. **CHECK FOR DAMAGED PARTS.** Before using the Cable Tray Bender and Vise, carefully check that it will operate properly and perform its intended function. Check for damaged parts and any other conditions that may affect its operation. Replace or repair damaged or worn parts immediately.
9. **REPLACEMENT PARTS AND ACCESSORIES.** When servicing, use only identical replacement parts. Only use accessories intended for use with this Cable Tray Bender and Vise. Approved accessories are available from Harbor Freight Tools.
10. **MAINTAIN CABLE TRAY BENDER AND VISE WITH CARE.** Keep this product clean and dry, and moving parts lightly lubricated for better and safer performance. Keep Handle dry, clean and free from oil, grease, and solvents.
11. **MAINTENANCE:** For your safety, service and maintenance should be performed regularly by a qualified technician
12. **USE THE RIGHT PRODUCT FOR THE RIGHT JOB.** There are certain applications for which this product was designed. Do not use this product for a purpose for which it was not intended.

## UNPACKING

When unpacking, check to make sure all parts shown on the Parts List (page #7) are included. If any parts are missing or broken, please call Harbor Freight Tools at the number shown on the cover of this manual as soon as possible.

## OPERATING INSTRUCTIONS

**NOTE: All parts below refer to the parts listed on page 7 of this manual.**

**NOTE: The Cable Bender and Vise produce bends in single flange cable trays, with flanges both inside and outside of the bend. When producing bends with the flange outward, the best results may be achieved without the use of the Bending Lever. In addition, most bending applications do not require the minimum radius of bends (refer to the following steps).**

**To Bend Tray — Flange Inward:**

1. Raise the Bending Lever (part #2) to a vertical position.
2. Insert tray under Bending Lever Roller (part #3) and Hinged Stop Bar (part #6).
3. Adjust Formers (part #5) to locate tray flanges in Former grooves.
4. Lower Bending Lever to rest on tray.
5. Apply even pressure through the Bending Lever until the required degree of bend is achieved.
6. Raise the Bending Lever to a vertical position. Release Hinged Stop Bar.

**To Bend Tray — Flange Outward:**

1. Place Bending Lever in a downward position.
2. Insert tray under Hinged Stop Bar. Remove tray flanges from Formers and remove tray from Cable Tray Bender and Vise.

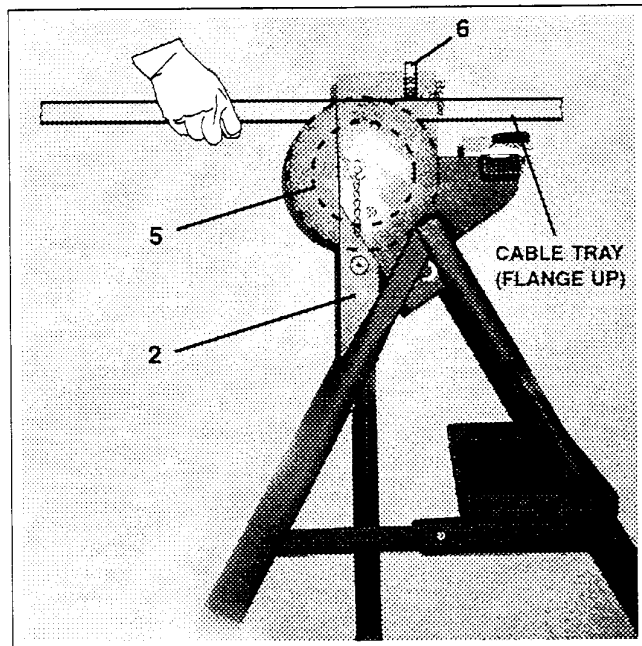

3. Adjust the Formers to allow tray to position itself on the knurled surface with its flanges tight against the Former Walls.
4. Firmly hold the tray with both hands on either side of the tray close to the point of bend. Apply even pressure upward and bend to the desired angle. If necessary, complete in small stages.
5. Release the Hinged Stop Bar and remove the tray from the Cable Tray Bender and Vise.

**WARNING: Caution keep hands and fingers clear of all moving parts.**

**To Bend A Larger Radius:**

1. Proceed as shown in the steps above, producing the bend by bending in small stages while moving the tray through a few inches at a time between the bends.

**To Bend Upward:**

1. Place Bending Lever in a downward position.
2. Position the tray over the Fixed Stop Bar (part #7) and proceed as shown below, pulling the Bending Lever upward while bending the flange inward.

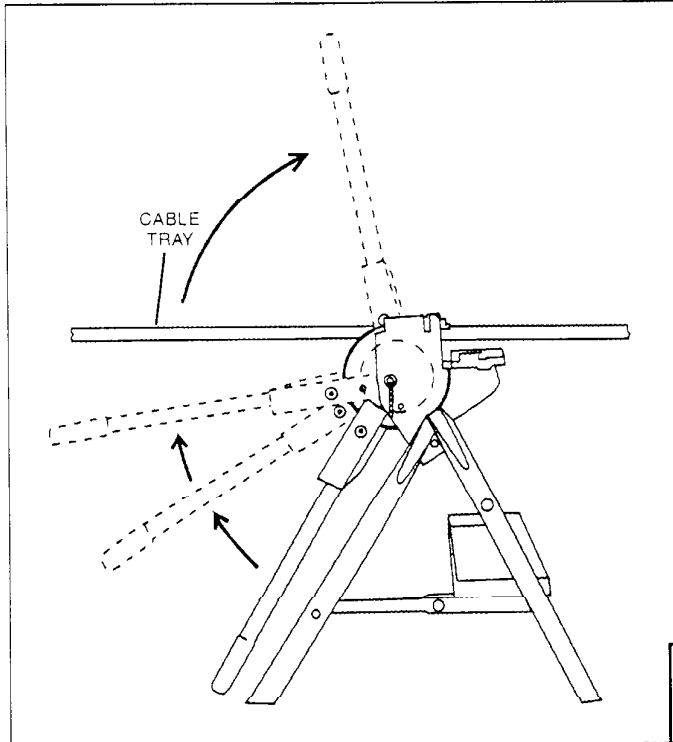

**To Use The Portable Vise:**

1. Place Bending Lever in a downward position.
2. Raise the Hinged Stop Bar and slide the Formers against the right and left sides of the side plates.
3. Position the tray on the Former Axle with one edge against the *left side* Aluminum Clamp (part #11).  
**NOTE:** Check to make sure the *left side* Aluminum Clamp is securely tightened, using the Bolt (part #10).
4. Release the *right side* Aluminum Clamp by loosening the Bolt.

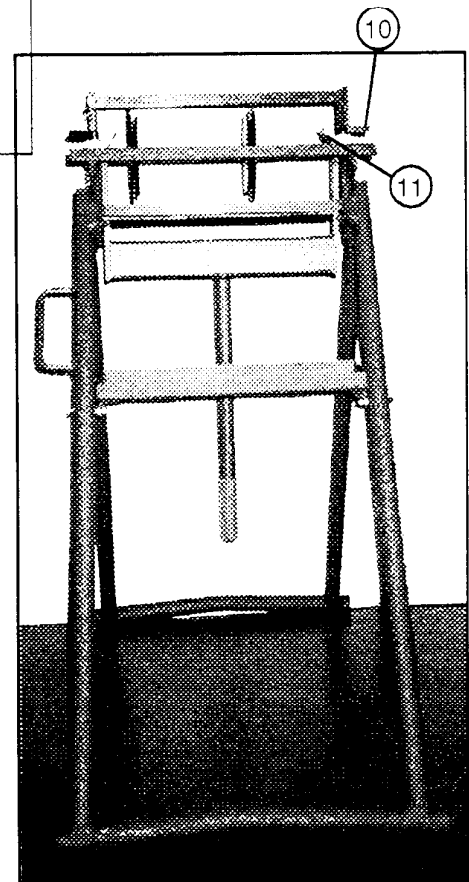

5. Slide the *right side* Aluminum Clamp to the side of the tray. Lock the *right side* Aluminum Clamp against the tray by tightening the Bolt.
6. To remove the tray, loosen the Bolt of the *right side* Aluminum Clamp and slide away from the tray.

## MAINTENANCE

1. **For better and safer performance, keep moving parts of the Cable Bender and Vise clean, dry, and lightly lubricated at all times.**

### PLEASE READ THE FOLLOWING CAREFULLY

THE MANUFACTURER AND/OR DISTRIBUTOR HAS PROVIDED THE PARTS DIAGRAM IN THIS MANUAL AS A REFERENCE TOOL ONLY. NEITHER THE MANUFACTURER NOR DISTRIBUTOR MAKES ANY REPRESENTATION OR WARRANTY OF ANY KIND TO THE BUYER THAT HE OR SHE IS QUALIFIED TO MAKE ANY REPAIRS TO THE PRODUCT OR THAT HE OR SHE IS QUALIFIED TO REPLACE ANY PARTS OF THE PRODUCT. IN FACT, THE MANUFACTURER AND/OR DISTRIBUTOR EXPRESSLY STATES THAT ALL REPAIRS AND PARTS REPLACEMENTS SHOULD BE UNDERTAKEN BY CERTIFIED AND LICENSED TECHNICIANS AND NOT BY THE BUYER. THE BUYER ASSUMES ALL RISK AND LIABILITY ARISING OUT OF HIS OR HER REPAIRS TO THE ORIGINAL PRODUCT OR REPLACEMENT PARTS THERETO, OR ARISING OUT OF HIS OR HER INSTALLATION OF REPLACEMENT PARTS THERETO.

**NOTE: Some parts are listed and shown for illustration purposes only, and are not available individually as replacement parts.**

**PARTS LIST**

<b>PART #</b>	<b>DESCRIPTION</b>	<b>QTY</b>
1	Plastic Handle	1
2	Bending Lever	1
3	Roller	1
4	Clamp	4
5	Formers	2
6	Hinged Stop Bar	1
7	Fixed Stop Bar	1
8	Pin	1
9	Stand	1
10	Bolt	2
11	Aluminum Clamp	2
12	Square Nut	2
13	Hex Bolt	3
14	Nut	3
15	Bolt	2
16	Pin	1
17	Former Axle	1
18	Roller	1
19	Tool Tray	1
20	Adjustable Vise	1

# ASSEMBLY ILLUSTRATION

