

User's Manual



DVS 150

Digital Video Scaler

Precautions

Safety Instructions • English



This symbol is intended to alert the user of important operating and maintenance (servicing) instructions in the literature provided with the equipment.



This symbol is intended to alert the user of the presence of uninsulated dangerous voltage within the product's enclosure that may present a risk of electric shock.

Caution

Read Instructions • Read and understand all safety and operating instructions before using the equipment.

Retain Instructions • The safety instructions should be kept for future reference.

Follow Warnings • Follow all warnings and instructions marked on the equipment or in the user information.

Avoid Attachments • Do not use tools or attachments that are not recommended by the equipment manufacturer because they may be hazardous.

Consignes de Sécurité • Français



Ce symbole sert à avertir l'utilisateur que la documentation fournie avec le matériel contient des instructions importantes concernant l'exploitation et la maintenance (réparation).



Ce symbole sert à avertir l'utilisateur de la présence dans le boîtier de l'appareil de tensions dangereuses non isolées posant des risques d'électrocution.

Attention

Lire les instructions • Prendre connaissance de toutes les consignes de sécurité et d'exploitation avant d'utiliser le matériel.

Conservier les instructions • Ranger les consignes de sécurité afin de pouvoir les consulter à l'avenir.

Respecter les avertissements • Observer tous les avertissements et consignes marqués sur le matériel ou présentés dans la documentation utilisateur.

Éviter les pièces de fixation • Ne pas utiliser de pièces de fixation ni d'outils non recommandés par le fabricant du matériel car cela risquerait de poser certains dangers.

Sicherheitsanleitungen • Deutsch



Dieses Symbol soll dem Benutzer in der im Lieferumfang enthaltenen Dokumentation besonders wichtige Hinweise zur Bedienung und Wartung (Instandhaltung) geben.



Dieses Symbol soll den Benutzer darauf aufmerksam machen, daß im Inneren des Gehäuses dieses Produktes gefährliche Spannungen, die nicht isoliert sind und die einen elektrischen Schock verursachen können, herrschen.

Achtung

Lesen der Anleitungen • Bevor Sie das Gerät zum ersten Mal verwenden, sollten Sie alle Sicherheits- und Bedienungsanleitungen genau durchlesen und verstehen.

Aufbewahren der Anleitungen • Die Hinweise zur elektrischen Sicherheit des Produktes sollten Sie aufbewahren, damit Sie im Bedarfsfall darauf zurückgreifen können.

Befolgen der Warnhinweise • Befolgen Sie alle Warnhinweise und Anleitungen auf dem Gerät oder in der Benutzerdokumentation.

Keine Zusatzgeräte • Verwenden Sie keine Werkzeuge oder Zusatzgeräte, die nicht ausdrücklich vom Hersteller empfohlen wurden, da diese eine Gefahrenquelle darstellen können.

Instrucciones de seguridad • Español



Este símbolo se utiliza para advertir al usuario sobre instrucciones importantes de operación y mantenimiento (o cambio de partes) que se desean destacar en el contenido de la documentación suministrada con los equipos.



Este símbolo se utiliza para advertir al usuario sobre la presencia de elementos con voltaje peligroso sin protección aislante, que puedan encontrarse dentro de la caja o alojamiento del producto, y que puedan representar riesgo de electrocución.

Precaucion

Leer las instrucciones • Leer y analizar todas las instrucciones de operación y seguridad, antes de usar el equipo.

Conservar las instrucciones • Conservar las instrucciones de seguridad para futura consulta.

Obedecer las advertencias • Todas las advertencias e instrucciones marcadas en el equipo o en la documentación del usuario, deben ser obedecidas.

Evitar el uso de accesorios • No usar herramientas o accesorios que no sean específicamente recomendados por el fabricante, ya que podrían implicar riesgos.

Warning

Power sources • This equipment should be operated only from the power source indicated on the product. This equipment is intended to be used with a main power system with a grounded (neutral) conductor. The third (grounding) pin is a safety feature, do not attempt to bypass or disable it.

Power disconnection • To remove power from the equipment safely, remove all power cords from the rear of the equipment, or the desktop power module (if detachable), or from the power source receptacle (wall plug).

Power cord protection • Power cords should be routed so that they are not likely to be stepped on or pinched by items placed upon or against them.

Servicing • Refer all servicing to qualified service personnel. There are no user-serviceable parts inside. To prevent the risk of shock, do not attempt to service this equipment yourself because opening or removing covers may expose you to dangerous voltage or other hazards.

Slots and openings • If the equipment has slots or holes in the enclosure, these are provided to prevent overheating of sensitive components inside. These openings must never be blocked by other objects.

Lithium battery • There is a danger of explosion if battery is incorrectly replaced. Replace it only with the same or equivalent type recommended by the manufacturer. Dispose of used batteries according to the manufacturer's instructions.

Avertissement

Alimentations • Ne faire fonctionner ce matériel qu'avec la source d'alimentation indiquée sur l'appareil. Ce matériel doit être utilisé avec une alimentation principale comportant un fil de terre (neutre). Le troisième contact (de mise à la terre) constitue un dispositif de sécurité : n'essayez pas de le contourner ni de le désactiver.

Déconnexion de l'alimentation • Pour mettre le matériel hors tension sans danger, déconnectez tous les cordons d'alimentation de l'arrière de l'appareil ou du module d'alimentation de bureau (s'il est amovible) ou encore de la prise secteur.

Protection du cordon d'alimentation • Acheminer les cordons d'alimentation de manière à ce que personne ne risque de marcher dessus et à ce qu'ils ne soient pas écrasés ou pincés par des objets.

Réparation-maintenance • Faire exécuter toutes les interventions de réparation-maintenance par un technicien qualifié. Aucun des éléments internes ne peut être réparé par l'utilisateur. Afin d'éviter tout danger d'électrocution, l'utilisateur ne doit pas essayer de procéder lui-même à ces opérations car l'ouverture ou le retrait des couvercles risquent de l'exposer à de hautes tensions et autres dangers.

Fentes et orifices • Si le boîtier de l'appareil comporte des fentes ou des orifices, ceux-ci servent à empêcher les composants internes sensibles de surchauffer. Ces ouvertures ne doivent jamais être bloquées par des objets.

Lithium Batterie • Il a danger d'explosion s'il y a un remplacement incorrect de la batterie. Remplacer uniquement avec une batterie du même type ou d'un type équivalent recommandée par le constructeur. Mettre au rebut les batteries usagées conformément aux instructions du fabricant.

Vorsicht

Stromquellen • Dieses Gerät sollte nur über die auf dem Produkt angegebene Stromquelle betrieben werden. Dieses Gerät wurde für eine Verwendung mit einer Hauptstromleitung mit einem geerdeten (neutralen) Leiter konzipiert. Der dritte Kontakt ist für einen Erdanschluß, und stellt eine Sicherheitsfunktion dar. Diese sollte nicht umgangen oder außer Betrieb gesetzt werden.

Stromunterbrechung • Um das Gerät auf sichere Weise vom Netz zu trennen, sollten Sie alle Netzkabel aus der Rückseite des Gerätes, aus der externen Stromversorgung (falls dies möglich ist) oder aus der Wandsteckdose ziehen.

Schutz des Netzkabels • Netzkabel sollten stets so verlegt werden, daß sie nicht im Weg liegen und niemand darauf treten kann oder Objekte darauf- oder unmittelbar dagegengestellt werden können.

Wartung • Alle Wartungsmaßnahmen sollten nur von qualifiziertem Servicepersonal durchgeführt werden. Die internen Komponenten des Gerätes sind wartungsfrei. Zur Vermeidung eines elektrischen Schocks versuchen Sie in keinem Fall, dieses Gerät selbst öffnen, da beim Entfernen der Abdeckungen die Gefahr eines elektrischen Schlags und/oder andere Gefahren bestehen.

Schlitze und Öffnungen • Wenn das Gerät Schlitze oder Löcher im Gehäuse aufweist, dienen diese zur Vermeidung einer Überhitzung der empfindlichen Teile im Inneren. Diese Öffnungen dürfen niemals von anderen Objekten blockiert werden.

Lithium-Batterie • Explosionsgefahr, falls die Batterie nicht richtig ersetzt wird. Ersetzen Sie verbrauchte Batterien nur durch den gleichen oder einen vergleichbaren Batterietyp, der auch vom Hersteller empfohlen wird. Entsorgen Sie verbrauchte Batterien bitte gemäß den Herstelleranweisungen.

Advertencia

Alimentación eléctrica • Este equipo debe conectarse únicamente a la fuente/tipo de alimentación eléctrica indicada en el mismo. La alimentación eléctrica de este equipo debe provenir de un sistema de distribución general con conductor neutro a tierra. La tercera pata (puesta a tierra) es una medida de seguridad, no puentearía ni eliminaría.

Desconexión de alimentación eléctrica • Para desconectar con seguridad la acometida de alimentación eléctrica al equipo, desenchufar todos los cables de alimentación en el panel trasero del equipo, o desenchufar el módulo de alimentación (si fuera independiente), o desenchufar el cable del receptáculo de la pared.

Protección del cables de alimentación • Los cables de alimentación eléctrica se deben instalar en lugares donde no sean pisados ni apretados por objetos que se puedan apoyar sobre ellos.

Reparaciones/mantenimiento • Solicitar siempre los servicios técnicos de personal calificado. En el interior no hay partes a las que el usuario deba acceder. Para evitar riesgo de electrocución, no intentar personalmente la reparación/mantenimiento de este equipo, ya que al abrir o extraer las tapas puede quedar expuesto a voltajes peligrosos u otros riesgos.

Ranuras y aberturas • Si el equipo posee ranuras o orificios en su caja/alojamiento, es para evitar el sobrecalentamiento de componentes internos sensibles. Estas aberturas nunca se deben obstruir con otros objetos.

Batería de litio • Existe riesgo de explosión si esta batería se coloca en la posición incorrecta. Cambiar esta batería únicamente con el mismo tipo (o su equivalente) recomendado por el fabricante. Desachar las baterías usadas siguiendo las instrucciones del fabricante.

Quick Start — DVS 150

Installation

Step 1

Install the four rubber feet on the bottom of the scaler (1A), or mount the scaler in a rack (1B).

Step 2

Turn off power to the input and output devices, and unplug their power cords.

Step 3

Attach the scaler to the input devices.

Input options (3) are:

- Composite video (input 1)
- Component video (input 2)
- S-video (input 3)
- RGB pass-thru (input 4)

Step 4

Attach the scaler to the output devices.

Output options (4) are:

- RGsB (connected to R, G, and B)
- RGBS (connected to R, G, B, and S)
- RGBHV (connected to R, G, B, H, and V)
- VGA/XGA/SVGA/SXGA (connected to RGB output connector)

Step 5

Plug the scaler, input device, and output device into a grounded AC source, and turn on the input and output devices.

Step 6

Use the LCD menu screens to configure the scaler (see the next page).

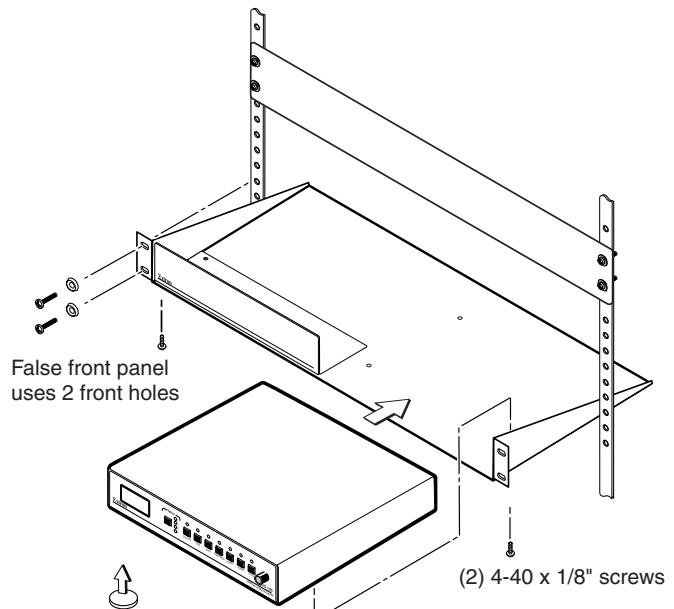

- 1A** Rubber feet bottom side (4 plcs) or **1B** Use 2 mounting holes on opposite corners

Input/Output Devices

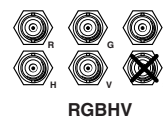
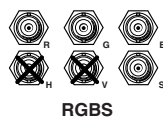
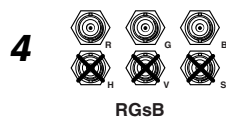
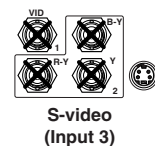
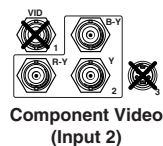
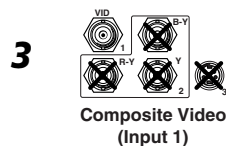
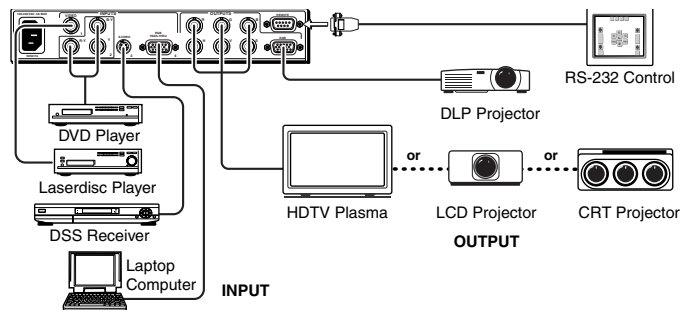

Quick Start — DVS 150, cont'd

Configuring the Scaler

Configuring the scaler: Press the input and rate buttons simultaneously, and hold them for two seconds.

Stepping through the LCD display menus: Press the input button.

Changing a selection: Turn the adjustment knob while the menu is displayed.

Exiting the menus: Press the input button while the Detail menu is displayed, or don't press any buttons or turn any knobs for eight seconds.

AUTOSW — Choose whether the DVS automatically selects the active input.

On: The scaler selects the active input automatically. **Off:** You select the input manually.

TOPBLANK — Add or remove additional blanking lines at the top of the image.

BOTBLANK — Add or remove additional blanking lines at the bottom of the image.

H-SYNC — Change the polarity of the horizontal sync signal to allow any projector to distinguish the DVS 150 input from a standard RGB input.

+: Sets the horizontal sync polarity to positive. **-**: Sets the horizontal sync polarity to negative.

V-SYNC — Change the polarity of the vertical sync signal to allow any projector to distinguish the DVS 150 input from a standard RGB input.

+: Sets the vertical sync polarity to positive. **-**: Sets the vertical sync polarity to negative.

SOG — Set the sync output format.

Yes: Sync on green (RGsB) output. **No:** RGBS or RGBHV output (based on unit cabling).

STILL — Enhance output for still or motion video.

On: Enhanced image for still video and text. **Off:** Enhanced image for motion video.

DETAIL — Apply a filter to improve image detail.

1: Low level of detail. **2:** Medium level of detail. **3:** High level of detail.

Operation

Choosing the input source: Press and release the input button until the desired input LED lights.

NOTE *If input 4 (RGB pass-through) is selected, you cannot make any of the following adjustments.*

Adjusting the image: Press the button for the adjustment, and rotate the adjustment knob until the desired result is achieved.

Choosing the output rate: Press and hold the rate button for two seconds, and then rotate the adjustment knob until the desired rate appears in the LCD display. Options are:

640x480 (VGA), 60/75 Hz	848x480 (plasma), 60 Hz	1280x768 (plasma), 56 Hz	480p (HDTV)
800x600 (SVGA), 60/75 Hz	852x480 (plasma), 60/75 Hz	1280x1024 (SXGA), 60 Hz	720p (HDTV)
832x624 (Mac), 60/75 Hz	1024x768 (XGA), 60/75 Hz	1360x765 (plasma), 60 Hz	1080p (HDTV)

Activating freeze mode: Issue the RS-232 freeze mode command.

Deactivating freeze mode: Press the input button or issue an RS-232 command.

Restoring default picture control settings (active input): Press and hold the input button for two seconds.

Restoring all settings to factory defaults: Press and hold the input button while attaching the AC power cord.

Table of Contents

Chapter 1 • Introduction	1-1
About the Scaler	1-2
Features	1-2
Chapter 2 • Installation	2-1
Rear Panel Features	2-2
Installation	2-2
Overview	2-2
Mounting the scaler	2-3
Installing the rubber feet	2-3
Cabling	2-4
Front Panel Features	2-5
Configuring the Scaler	2-6
Configuration settings	2-6
Chapter 3 • Operation	3-1
Front Panel Operation	3-2
Default screens	3-2
Choosing the input source	3-2
Adjusting an image	3-2
Choosing the output rate	3-3
Freeze mode	3-4
Executive mode	3-4
Resetting the scaler	3-4
Channel reset	3-4
System reset	3-4
Chapter 4 • Serial Communication	4-1
RS-232 Programmer's Guide	4-2
DVS initiated messages	4-2
DVS error response	4-3
Using the command/response table	4-3
Command/response table	4-4
Remote Contact Closure Operation	4-3
Control Software for Windows	4-5
Installing the software	4-5
Using the software	4-6
Chapter 5 • Troubleshooting	5-1
Operating Problems	5-2

Table of Contents, cont'd

Appendix • Reference Information	A-1
Specifications	A-2
Part Numbers	A-3
DVS 150 part numbers	A-3
Related part numbers	A-3
BNC cables	A-3
Bulk cable	A-3
Assorted connectors	A-4
Precut cables	A-4

68-459-01 D
Printed in the USA
06 00



DVS 150

Chapter One

Introduction

About the Scaler

Features

Introduction

About the Scaler

Extron's DVS 150 digital video scaler allows analog video signals (composite video, S-video, and component video) to be displayed on a device with a fixed resolution and aspect ratio, such as an LCD (liquid crystal display) projector, DLP (digital light processing) projector, or plasma display.

The DVS 150 includes a 15-pin HD RGB pass-through connector for RGB input. Video signals coming into the scaler from this connector are not scaled. Instead, they are passed directly to the outputs.

Features

- **Autosave** — Automatically stores adjustments and uses the control settings associated with the selected input.
- **Autoswitch mode** — Automatically selects the active input device. If more than one input device is on, the device with the highest video quality is selected.
- **Blanking** — Allows noise or unwanted information, such as tape head switching and closed captioning, to be eliminated from the top and bottom of the display.
- **Dual output connectors** — Allow you to connect and run two output devices simultaneously.
- **Executive mode** — Locks out all front-panel image adjustment functions except input selection. When executive mode is active, all image adjustments are available through RS-232 commands.
- **Freeze mode** — Locks the output display to the current image.
- **Inputs** — Includes three BNC connectors for component video, one BNC connector for composite video, and one 4-pin mini-DIN connector for S-video. The DVS 150 also includes one 15-pin HD connector for RGB pass-through input.
- **Multiple control methods** — Allow you to make adjustments by pressing a button on the front panel, choosing options from a menu, sending an RS-232 command from a computer, or using a remote contact closure control.
- **Outputs** — Outputs video as RGB, RGsB, RGbS, and RGBHV. BNC connectors and a 15-pin HD connector are provided.
- **Output resolutions** — Supports the following output resolutions:
 - 640 x 480 (VGA) at 60 or 75 Hz (Hertz)
 - 800 x 600 (SVGA) at 60 or 75 Hz
 - 832 x 624 (Macintosh) at 60 or 75 Hz
 - 848 x 480 (plasma) at 60 Hz
 - 852 x 480 (plasma) at 60 or 75 Hz
 - 1024 x 768 (XGA) at 60 or 75 Hz
 - 1280 x 768 (plasma) at 56 Hz
 - 1280 x 1024 (SXGA) at 60 Hz
 - 1360 x 765 (plasma) at 60 Hz
 - 480p (HDTV)
 - 720p (HDTV)
 - 1080p (HDTV)

-
- **Power supply** — Includes an internal, 100-240VAC, 50/60 Hz, auto-switchable power supply.
 - **Precise image processing** — Provides the latest in *motion compensation*, which produces motion images that are free of jaggies; a *three-line adaptive comb filter*, which eliminates chroma crawl; and a *quad standard decoder*, which ensures compatibility with NTSC (National Television Standards Committee) 3.58, NTSC 4.43, SECAM (sequential couleur avec mémoire), and PAL (phase alternate line) video standards.
 - **Software-based configuration** — Allows you to configure the scaler through menu controls, simplifying installation.
 - **Switchable sync polarities** — Allow you to manually set the horizontal and vertical sync polarities, to allow the output device to store DVS input as a unique input.

Introduction, cont'd



DVS 150

Chapter Two

Installation

Rear Panel Features

Installation

Front Panel Features

Configuring the Scaler

Installation

Rear Panel Features

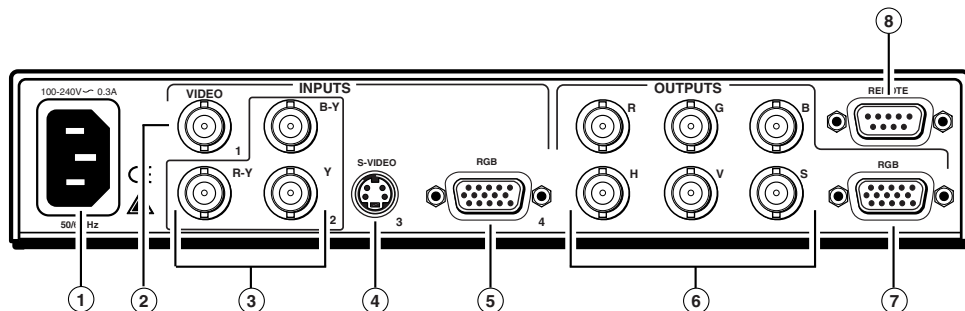

Figure 1 — DVS 150 rear panel

- ① **AC power connector** — Standard AC power connector attaches the scaler to any power source from 100VAC to 240VAC, operating at 50 Hz or 60 Hz.
- ② **Composite video input connector** — One BNC female connector for composite video input.
- ③ **Component video input connectors** — Three BNC female connectors for component (R-Y, B-Y, Y) video input.
- ④ **S-video input connector** — One 4-pin mini-DIN female connector for S-video input.
- ⑤ **RGB pass-thru connector** — One 15-pin HD female RGB connector for input. The signal from the input device is passed through to the output connectors without being scaled.
- ⑥ **Output connectors** — BNC female connectors for RGsB (sync on green), RGBS (composite sync), or RGBHV output.
- ⑦ **RGB output connector** — One 15-pin HD female RGB connector for the output projector.
- ⑧ **RS-232/contact closure remote connector** — One 9-pin D female connector that allows you to attach a computer or another device, such as a keypad or other contact closure device, for remote control of the scaler.

NOTE You can install and run two output devices simultaneously, one using BNC connectors, and the other using the RGB connector.

Installation

Overview

To install and set up the DVS 150, follow these basic steps:

- ① If desired, mount the scaler in a rack (see “Mounting the scaler” on page 2-3). Otherwise, install the rubber feet (see “Installing the rubber feet” on page 2-3).
- ② Turn off power to the input and output devices, and unplug the power cables from them.
- ③ Attach the scaler to the input devices and the output devices. See “Cabling” on page 2-4.
- ④ Plug the scaler, input devices, and output devices into a grounded AC source.
- ⑤ Turn on the input and output devices.

- 6 Use the LCD menu screens to configure the scaler. See “Configuring the Scaler” on page 2-6.
- 7 The image from the input device should appear on the output device. If it does not, double check steps 3 and 4 and make adjustments as needed, and then see “Operating Problems” on page 5-2.

Mounting the scaler

Each DVS 150 ships with four uninstalled rubber feet. If you are going to rack mount the unit, do so before cabling it, and do not install the rubber feet. If you are not rack mounting the scaler, skip to “Installing the rubber feet” below.

The DVS 150 can be rack mounted using one side of an optional 19” 1U Universal Rack Shelf (Extron part # 60-190-01).

To rack mount the scaler, do the following:

1. If rubber feet were previously installed on the bottom of the case, remove them.
2. Mount the scaler on the rack shelf as shown in figure 2. Use two 4-40 x 1/8” screws in opposite (diagonal) corners to secure the case to the shelf.

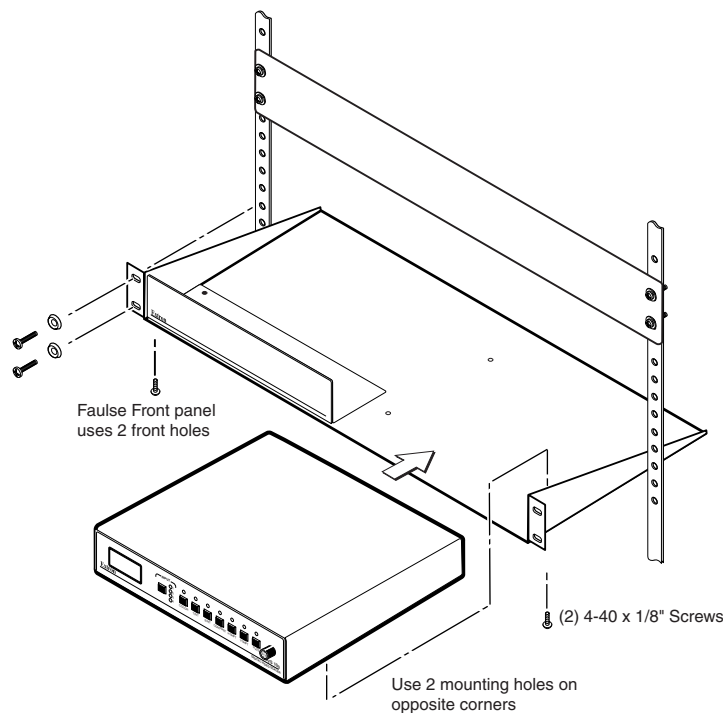

Figure 2 — Mounting the scaler

Installing the rubber feet

The scaler ships with four uninstalled rubber feet. Install the rubber feet only if you are not rack mounting the scaler. To install the rubber feet, do the following:

1. Turn the scaler upside down and place it on a flat surface.
2. Remove the protective backing from a rubber foot.

Installation, cont'd

- Place the rubber foot on one corner of the scaler, and press it into place.

NOTE Position the rubber foot carefully before pressing it into place. It is difficult to move the foot after it is in place.

- Repeat steps 2 and 3 to install a rubber foot on each of the remaining corners of the scaler.
- Turn the scaler right side up and place it in the desired location.

Cabling

The scaler can connect to input devices that produce composite video, S-video, or component video, and it can connect to input devices that produce RGB video via the RGB pass-through connector. The scaler can connect to output devices such as LCD projectors, DLP displays, or plasma displays

To cable the scaler, complete the following steps. Use figure 4 as a general guide.

- Attach the input device (or devices) to the scaler. Figure 3 shows each of the connection options.



Figure 3 — Input connections

NOTE You can attach up to three input devices, one each of composite video, S-video, and component video. You can also connect an RGB input device for pass-through to the output. You can select among the input sources via the input selection switch on the front panel.

NOTE If there is no video input, the LCD displays "No Source".

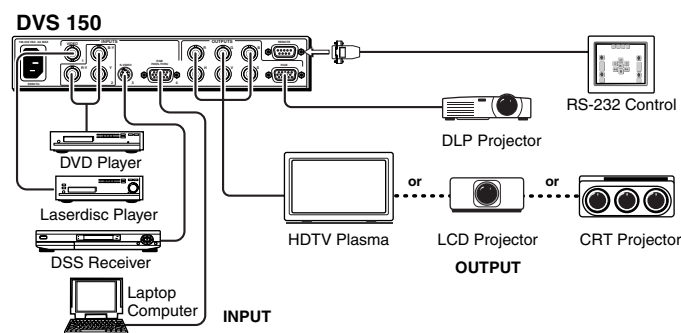

Figure 4 — Cabling the scaler

- Use BNC connectors or a 15-pin HD connector to connect the scaler to the output device. Figure 5 shows each of the connection options.

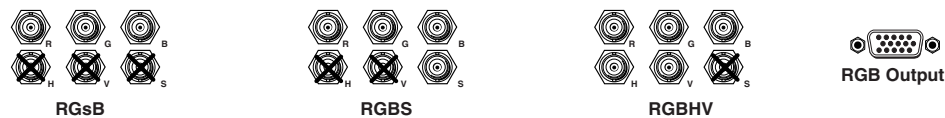

Figure 5 — Output connections

NOTE If you cable the scaler for sync on green (RGsB or SOG) output, you must also configure the scaler for SOG via the configuration menu. See "Configuring the Scaler" on page 2-6 for instructions.

NOTE You can install and run two output devices simultaneously, one using BNC connectors, and the other using the RGB connector.

Front Panel Features

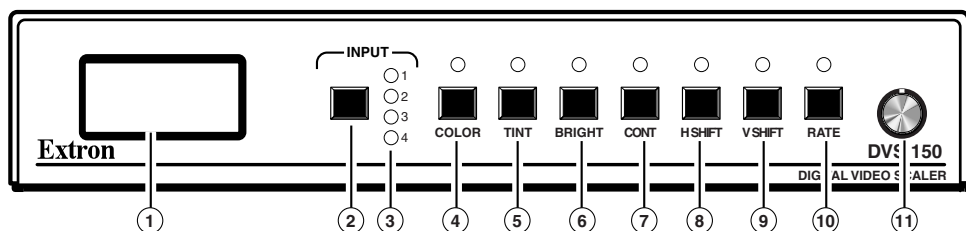

Figure 6 — DVS 150 front panel

- ① **LCD** — Displays configuration menus and status information. See “Configuring the Scaler” on page 2-6 and “Adjusting an image” on page 3-2.
- ② **Input button** — Allows you to select the input type (see “Choosing the input source” on page 3-2). If the image has been frozen via an RS-232 command, the input button cancels the freeze function (see “Freeze mode” on page 3-4).
- ③ **Input LEDs** — Display the active input. If LED (light emitting diode) 1 is lit, the input is composite video. If LED 2 is lit, the input is component video. If LED 3 is lit, the input is S-video. If LED 4 is lit, the input is RGB (from the pass-through connector).

NOTE The following adjustments are not available if the input is RGB pass-through.

- ④ **Color control button** — Allows you to adjust the image color. For more information, see “Adjusting an image” on page 3-2.
- ⑤ **Tint control button** — Allows you to adjust the image tint. For more information, see “Adjusting an image” on page 3-2. This control is not available if the input is component video.
- ⑥ **Brightness control button** — Allows you to adjust the image brightness. For more information, see “Adjusting an image” on page 3-2.
- ⑦ **Contrast control button** — Allows you to adjust the image contrast. For more information, see “Adjusting an image” on page 3-2.
- ⑧ **Horizontal shift control button** — Allows you to adjust the horizontal shift. For more information, see “Adjusting an image” on page 3-2.
- ⑨ **Vertical shift control button** — Allows you to adjust the vertical shift. For more information, see “Adjusting an image” on page 3-2.
- ⑩ **Output rate control button** — Allows you to choose the output rate. For more information, see “Choosing the output rate” on page 3-3.
- ⑪ **Adjustment knob** — With a control button selected, allows you to make adjustments to the feature controlled by the button. For example, if the horizontal shift control button is selected, turning the adjustment knob moves the image to the right or left.

Configuring the Scaler

The LCD on the front panel of the scaler provides access to a menu that allows you to configure the scaler.

- To access the menu, press the input button and the rate button simultaneously, and hold them for two seconds. The Autoswitch menu appears in the LCD.
- To step through the menus, press the input button.
- To exit the menu, step through the menus until the Detail menu appears, and then press the input button one more time. Or, wait eight seconds without pressing any buttons or turning the adjust knob, and the menu reverts to the default screens.

Configuration settings

Autoswitch (AUTOSW) — If set to On, automatically selects the input source that uses the highest video quality. If set to Off, allows you to manually specify the input source by pressing the input button on the front panel. To toggle between On and Off, turn the adjustment knob while the Autoswitch menu is displayed. By default, autoswitch mode is Off.

Top blanking (TOPBLANK) — Removes noise and unwanted information, such as tape head switching and closed captions, from the top of the screen. To change the top blanking level, turn the adjustment knob while the Top blanking menu is displayed, until the unwanted information no longer appears.

Bottom blanking (BOTBLANK) — Removes noise and unwanted information, such as tape head switching and closed captions, from the bottom of the screen. To change the bottom blanking level, turn the adjustment knob while the Bottom blanking menu is displayed, until the unwanted information no longer appears.

Horizontal sync polarity (H-SYNC) — Changes the polarity of the horizontal sync signal to allow any projector to distinguish the scaler input from a standard RGB input. To toggle between Positive and Negative, turn the adjustment knob while the Horizontal sync menu is displayed. By default, the horizontal sync polarity is set to Negative.

Vertical sync polarity (V-SYNC) — Changes the polarity of the vertical sync signal to allow any projector to distinguish the DVS 150 input from a standard RGB input. To toggle between Positive and Negative, turn the adjustment knob while the Vertical sync menu is displayed. By default, the vertical sync polarity is set to Negative.

Sync on green (SOG) — If set to Yes, provides sync on green (RGsB or SOG) output. If set to No, provides RGBS or RGBHV output, depending on the attached cables. To toggle between Yes and No, turn the adjustment knob while the Sync on green menu is displayed. By default, Sync on green is set to No.

Still (STILL) — If set to On, provides enhanced resolution for easier viewing of text and other motionless video. If set to Off, provides optimized motion video. To toggle between On and Off, turn the adjustment knob while the Still menu is displayed. By default, still mode is set to Off.

Detail (DETAIL) — Applies a filter to improve the image's level of detail. To switch between 1 (low), 2 (medium), and 3 (high), turn the adjustment knob while the Detail menu is displayed. By default, detail mode is set to 3.

VCR mode — Can eliminate horizontal noise if it is seen in a VCR image. To toggle between On and Off, turn the adjustment knob while the VCR mode menu is displayed. By default, VCR mode is set to Off.

Blue mode — Turns off the red and green video output to allow you to set up color and tint using a color bar pattern. To toggle between On and Off, turn the adjustment knob while the Blue mode menu is displayed. By default, blue mode is set to Off.

Installation, cont'd



DVS 150

Chapter Three

Operation

Front Panel Operation

Operation

Front Panel Operation

The front panel includes an LCD screen that displays the current status of the scaler and the scan rate of the current video input signal. You can also use controls on the front panel to control the image display.

NOTE A diagrams of the front panel is shown on page 2-5.

Default screens

By default, the LCD toggles between two screens every four seconds. One screen displays the product name, and the other shows the output resolution and frequency (figure 6 shows an example).

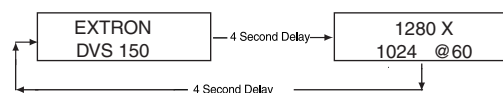

Figure 6 — Default screens

If no input signal is present, the LCD backlight turns off and the LCD toggles between the screens shown in figure 7.

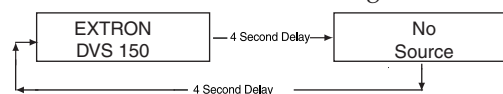

Figure 7 — No signal present

Choosing the input source

To choose an input source, press and release the input button to cycle through the inputs. The LED corresponding to the selected input lights:

- **Input LED 1** — Composite video
- **Input LED 2** — Component video
- **Input LED 3** — S-video
- **Input LED 4** — RGB pass-through video

NOTE Do not press the input button for two seconds or more, or you will reset the picture control settings for the active input to their factory defaults.

When the button is released, the input changes and the LCD shows the current input and signal type (see figure 8). The message appears for 8 seconds, and then changes back to the default screens.



Figure 8 — Current input screens

NOTE If an RS-232 command was issued to activate the freeze function, to change the input source you must press the input selection button twice. The first press unfreezes the image, and the second changes the input source.

Adjusting an image

The front panel controls allow you to make adjustments to the displayed image. To make an adjustment, do the following:

1. Push the control button that corresponds to the adjustment you want to make. The LED above the pressed button lights, and, depending on the selected button, the LCD displays the current level value for the adjustment.

- Turn the adjustment knob until the desired adjustment is accomplished. The LCD returns to the default screens, and the adjusted value is saved for future use by the active input, if you press the same button again or if you stop turning the knob for eight seconds.

If an image control reaches its minimum, maximum, or default level, the LCD displays a screen similar to the screens shown in figure 9.



Figure 9 — Minimum, maximum, and default value screens

NOTE *If input 4 (RGB pass-through) is selected, you cannot adjust the image through the scaler.*

Color control button — Adjusts the color intensity.

Tint control button — Adjusts the amount of tint displayed. This adjustment is not available if the input is component video.

Brightness control button — Adjusts the amount or intensity of video light produced on the screen, without regard to color.

Contrast control button — Adjusts the range of light and dark values in a picture, or the ratio between the maximum and the minimum brightness values.

Horizontal shift control button — Shifts the image to the left and right.

Vertical shift control button — Shifts the image up and down.

Choosing the output rate

NOTE *If input 4 (RGB pass-through) is selected, you cannot change the output rate through the scaler.*

To choose the output rate, do the following:

- Refer to the documentation that accompanied the display device to determine its native mode (or *sweet spot*).
- Press and hold the rate button on the scaler for two seconds. The LED above the button lights, and the LCD displays the current output resolution and frequency.
- Turn the adjustment knob until the desired output rate appears in the LCD and the image is displayed at the correct rate.

Available rates are:

- 640 x 480, 60 Hz
- 800 x 600, 60 Hz
- 832 x 624, 60 Hz
- 848 x 480, 60 Hz
- 852 x 480, 60 Hz
- 1024 x 768, 60 Hz
- 1280 x 768, 56 Hz
- 1360 x 765, 60 Hz
- HDTV 480p
- HDTV 720p
- HDTV 1080p
- 640 x 480, 75 Hz
- 800 x 600, 75 Hz
- 832 x 624, 75 Hz
- 852 x 480, 75 Hz
- 1024 x 768, 75 Hz
- 1280 x 1024, 60 Hz

Operation, cont'd

Freeze mode

Freeze mode locks the output display to the current image. Freeze mode can be activated only by issuing an RS-232 command (see chapter 4 for more information). If freeze mode is activated, the LCD screen displays the message displayed at the left.

IMAGE
FROZEN

NOTE *If input 4 (RGB pass-through) is selected, you cannot activate freeze mode.*

You can deactivate freeze mode in the following ways:

- By issuing another RS-232 command
- By pressing the input button
- Automatically, if the scaler is in autoswitch mode and the input source changes.

Executive mode

Executive mode limits the number of operations available from the front panel. This is useful for situations in which many end users operate the scaler, and you want to prevent them from changing the adjustments you have made.

To enable executive mode, press the horizontal shift and vertical shift control buttons simultaneously for two seconds. The LCD displays the message at the left for eight seconds, and then changes back to the default screens.

X-MODE
ENABLED

When executive mode is enabled, the only front panel button that can be used is the input selection button. If any other button is pressed, the LCD displays the same message for eight seconds, then changes back to the default screens.

To disable executive mode, press the horizontal shift and vertical shift control buttons simultaneously for two seconds. The LCD displays the message at the left for eight seconds, then changes back to the default screens.

X-MODE
DISABLED

Resetting the scaler

You can perform two types of reset:

- *Channel reset* restores the factory default picture control settings (color, tint, brightness, contrast, horizontal shift, and vertical shift) for only the currently selected input.

NOTE *If input 4 (RGB pass-through) is selected, you cannot perform a channel reset.*

- *System reset* restores all factory default settings, including all picture controls for all inputs, the output rate, and all configuration options available from the LCD menu.

Channel reset

To perform a channel reset, press and hold the input button for two seconds. The picture control settings for the active input are reset to their factory default settings. The LCD displays a message similar to the one at the left for four seconds, and then changes back to the default screens.

INPUT 1
RESET

System reset

To perform a system reset, press and hold the input button while attaching the AC power cord. The picture control settings for all input sources, the output rates, and the configuration options are reset to their factory default settings. The LCD displays the message at the left for four seconds, and then changes back to the default screens.

SYSTEM
RESET



DVS 150

4 Chapter Four

Serial Communication

RS-232 Programmer's Guide

Remote Contact Closure Operation

Control Software for Windows

Serial Communication

The scaler's RS-232 connector can be connected to the serial port output of a host device such as a computer or control system. This connection makes software control of the scaler possible. Figure 10 shows a scaler RS-232 connection to a host serial port connector.

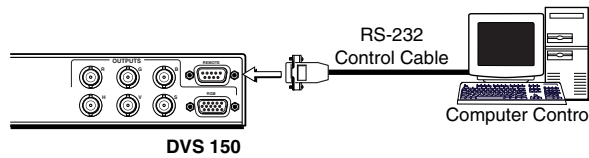

Figure 10 — Scaler RS-232 to host connection

The RS-232 connector on the scaler is a 9-pin D female connector with the following pin assignments:

Pin	Description
1	Input 1 select*
2	Transmit data
3	Receive data
4	Input 2 select*
5	Signal ground
6	Input 3 select*
7	Input 4 select*
8	Not used
9	Not used

* Used for remote contact closure control

The protocol is 9600 baud, 8-bit, 1 stop bit, no parity, and no flow control.

The scaler accepts SIS™ (Simple Instruction Set™) commands through the RS-232 port. SIS commands consist of one or more characters per command field. They do not require any special characters to begin or end the command character sequence. Each scaler response to an SIS command ends with a carriage return and a line feed (CR/LF = ↵), which signals the end of the response character string. (A string is one or more characters.)

RS-232 Programmer's Guide

DVS initiated messages

When a local event occurs, such as a front panel operation, the scaler responds by sending a message to the host. The DVS-initiated messages are listed below (underlined).

(C) Copyright 1999, Extron Electronics, DVS 150, Vx.xx ↵

The copyright message is initiated by the scaler when it is first powered on. Vx.xx is the firmware version number.

Reconfig ↵

The Reconfig message is initiated by the scaler when a new input is selected or when any image adjustment is made.

The scaler does not expect a response from the host, but, for example, the host program might request a new status.

DVS error response

When the scaler receives an SIS command and determines that it is valid, it performs the command and sends a response back to the host device. If the scaler is unable to perform the command because the command is invalid or contains invalid parameters, the scaler returns an error response to the host. The error response codes are:

- E01 — Invalid input channel number (too large)
- E09 — Invalid function number (too large)
- E10 — Invalid command
- E13 — Invalid value (out of range)

Using the command/response table

The command/response table is shown on the next page. Lower case characters are acceptable in the command field only where indicated. Symbols are used throughout the table to represent variables in the command/response fields. Symbol definitions are shown at the beginning of the table, as is an ASCII-to-hexadecimal (HEX) conversion table. Command and response examples are shown throughout the table.

NOTE *Screen adjustment commands are not available if input 4 is selected.*

Remote Contact Closure Operation

The RS-232 connector provides a way to control the scaler from a remote contact closure device. This is made possible by using pins that are not normally used by the RS-232 interface. The contact closure pin assignments are shown in the table on page 4-2.

To select a different input number through the RS-232 connector, momentarily short the pin for the desired input number (#) to the signal ground (pin 5). To force one of the inputs to be selected continuously, leave the short to signal ground in place. This will override any front panel input selection.

Serial Communication, cont'd

Command/response table

Symbol definitions: ↵ = CR/LF, • = space

- [X1]** = Inputs = 1 = Composite
 2 = Component
 3 = S-video
 4 = RGB
[X2] = Adjustment range 1-127
[X3] = Output rate = 1 = 640x480 @ 60 Hz
 2 = 640x480 @ 75 Hz
 3 = 800x600 @ 60 Hz
 4 = 800x600 @ 75 Hz
 5 = 832x624 @ 60 Hz
 6 = 832x624 @ 75 Hz
 7 = 852x480 @ 60 Hz
 8 = 852x480 @ 75 Hz
 9 = 1024x768 @ 60 Hz
 10 = 1024x768 @ 75 Hz
 11 = 1280x1024 @ 60 Hz
 12 = 480p
 13 = 720p
 14 = 1080p
 15 = 848x480 @ 60 Hz
 16 = 1280x768 @ 56 Hz
 17 = 1360x765 @ 60 Hz

ASCII to HEX Conversion Table								Esc	1B	CR	0D	LF	0A		
20	!	21	"	22	#	23	\$	24	%	25	&	26	'	27	
(28)	29	*	2A	+	2B	,	2C	-	2D	.	2E	/	2F
0	30	1	31	2	32	3	33	4	34	5	35	6	36	7	37
8	38	9	39	:	3A	;	3B	<	3C	=	3D	>	3E	?	3F
@	40	A	41	B	42	C	43	D	44	E	45	F	46	G	47
H	48	I	49	J	4A	K	4B	L	4C	M	4D	N	4E	O	4F
P	50	Q	51	R	52	S	53	T	54	U	55	V	56	W	57
X	58	Y	59	Z	5A	[5B	\	5C]	5D	^	5E	_	5F
`	60	a	61	b	62	c	63	d	64	e	65	f	66	g	67
h	68	i	69	j	6A	k	6B	l	6C	m	6D	n	6E	o	6F
p	70	q	71	r	72	s	73	t	74	u	75	v	76	w	77
x	78	y	79	z	7A	{	7B		7C	}	7D	~	7E	DEL	7F

[X4] = 1 = On, 0 = Off

[X5] = Input type 0 = None
 1 = NTSC 3.58
 2 = PAL
 3 = NTSC 4.43
 4 = SECAM

[X6] = Detail level 1 = Low
 2 = Medium
 3 = High

COMMAND	ASCII	RESPONSE	DESCRIPTION
Input selection			
	[X1] !	C [X1] ↵	Sets input source
Color			
Specific value	[X2] C	Col [X2] ↵	Selects color [X2]
Increment up	{ C	Col [X2] ↵	Selects next higher color value
Increment down	} C	Col [X2] ↵	Selects next lower color value
Tint			
Specific value	[X2] T	Tin [X2] ↵	Selects tint [X2]
Increment up	{ T	Tin [X2] ↵	Selects next higher tint value
Increment down	} T	Tin [X2] ↵	Selects next lower tint value
Contrast			
Specific value	[X2] ^	Con [X2] ↵	Selects contrast [X2]
Increment up	{ ^	Con [X2] ↵	Selects next higher contrast value
Increment down	} ^	Con [X2] ↵	Selects next lower contrast value
Brightness			
Specific value	[X2] Y	Brn [X2] ↵	Selects brightness [X2]
Increment up	{ Y	Brn [X2] ↵	Selects next higher brightness value
Increment down	} Y	Brn [X2] ↵	Selects next lower brightness value
Horizontal shift			
Specific value	[X2] H	Hph [X2] ↵	Selects horizontal shift [X2]
Increment up	{ H	Hph+ ↵	Shift image right one step
Increment down	} H	Hph- ↵	Shift image left one step

COMMAND	ASCII	RESPONSE	DESCRIPTION
Vertical shift			
Specific value	[X2] /	Vph [X2] ↵	Selects vertical shift [X2]
Increment up	{/	Vph+ ↵	Shift image up one step
Increment down	}/	Vph- ↵	Shift image down one step
Set output rate			
	[X3] =	Rte [X3] ↵	Set the video output rate
Freeze			
Enable	F	Frz 1 ↵	Set freeze mode to On (freeze current displayed image)
Disable	f	Frz Ø ↵	Set freeze mode to Off
Executive mode			
Enable	X	Exe 1 ↵	Set executive mode to On
Disable	x	Exe Ø ↵	Set executive mode to Off
Query software version			
	q	(Same as Q below)	
	Q	Ver x.xx ↵	Example response: Ver 3.2 ↵
Still mode			
	[X4] #	Stl [X4] ↵	Sets still mode On or Off
Detail mode			
	[X6] D	Det [X6] ↵	Sets detail mode to level 1 (low), 2, or 3 (high)
Request part number			
	n	(Same as N below)	
	N	N6Ø-317-Ø1 ↵	Displays the Extron part number
Request information*			
	i	(Same as I below)	
	I	C[X1]•Col[X2]•Tin[X2]•Con[X2]•Brn[X2]•Hph[X2]•Vph[X2]•Rte[X3]•Frz[X4] •Exe[X4]•Typ[X5]•Stl[X4]•Det[X6] ↵	

* Typ[X5] displays the type of input video signal as automatically sensed by the scaler. You cannot change this entry.

Control Software for Windows

The *Signal Enhancement Products Control Program* (part # 29-017-01), which is used by the scalers, is compatible with Windows 3.1, 3.11, 95/98, and NT. It provides remote control of scaler settings. Use version 3.2 or later.

Installing the software

The program is contained on a single 3.5-inch diskette, and it can run from the floppy drive. However, it is usually more convenient to load and run the program from the hard drive.

To install the software from the floppy disk onto the hard drive, run SETUP.EXE from the floppy disk, and follow the instructions that appear on the screen. The program occupies approximately 1 MB (megabyte) of hard-drive space.

By default, the Windows installation creates a C:\S_ENHANC directory, and it places two icons (Signal Enhancement Products Control Pgm and Signal Enhancement Products Help) into a group or folder named "Extron Electronics".

Serial Communication, cont'd

Using the software

- To run the Signal Enhancement Products Control Program, double-click on the Signal Enhancement Products Control Pgm icon in the Extron Electronics group or folder.



The Comm menu appears on the screen.

- Click on the comm port that is connected to the scaler's RS-232 port. The Extron Signal Enhancement Products Control Program window appears. It displays the current settings and input type detected (see figure 11).

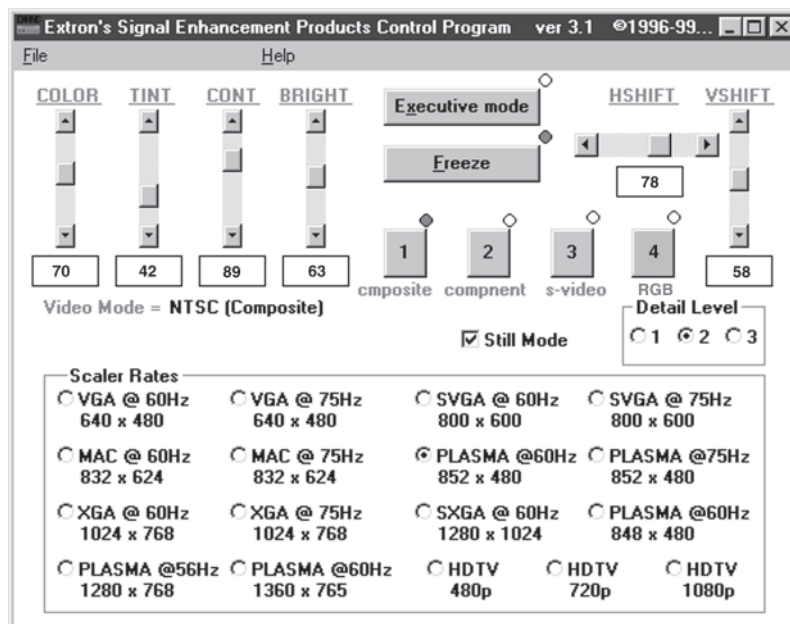

Figure 11 — Signal Enhancement Products Control Program

- Using normal Windows controls, you can perform the same adjustments as from the front panel.

For information about program features, you can access the Help program in any of the following ways:

- From the Extron Electronics program folder or group, double-click on the Signal Enhancement Products Help icon.



- From within the Signal Enhancement Products Control Program, click on the Help menu on the main screen.
- From within the Signal Enhancement Products Control Program, press the F1 key.



DVS 150

5

Chapter Five

Troubleshooting

Operating Problems

Troubleshooting

This section gives recommendations on what to do if you have problems operating the DVS 150, and it provides examples and descriptions for some image problems you might encounter.

Following are some tips to help you in troubleshooting.

1. Some symptoms may resemble others, so you may want to look through all of the examples before attacking the problem.
2. Be prepared to backtrack in case the action taken doesn't solve the problem.
3. It may help to keep notes and sketches in case the troubleshooting process gets lengthy. This will also give you something to discuss if you call for technical support.
4. Try simplifying the system by eliminating components that may have introduced the problem or made it more complicated.
5. For sync-related problems: Portable digital projectors are designed to operate close to the video source. Sync problems may result from using long cables or from improper termination. A sync adapter, such as Extron's ASTA (active sync termination adapter), may help solve these problems.
6. For LCD and DLP projectors and plasma displays: In addition to the sync-related information above, check the user's manual that came with the projector for troubleshooting tips, as well as for settings and adjustments. Each manufacturer may have its own terms, so look for terms like "auto setup", "auto sync", "pixel phase", and "tracking".

Operating Problems

The table below shows some common operating problems and their solutions.

Problem	Cause	Solution
No image appears.	The input signal is incompatible.	Attach an input device that is compatible with NTSC 3.58, NTSC 4.43, PAL, or SECAM.
	Freeze mode was entered when the image was black.	Deactivate freeze mode (page 3-4).
	The scaled output rate is too high for the display.	Change the scaled output to a compatible resolution (page 3-3).
The image is frozen.	Freeze mode is on.	Deactivate freeze mode (page 3-4). If that does not work, unplug the power cord from the scaler, then plug it back in.
The image is flashing.	The scaled output rate is too high for the display.	Change the scaled output to a compatible resolution (page 3-3).
Inputs cannot be switched.	Autoswitch is turned on.	Turn off autoswitch (page 2-6).

Problem	Cause	Solution
Picture controls are not active.	Input 4 is selected.	Switch to input 1–3. Input 4 is pass-through only (page 1-2).
The image is green.	The unit is configured for sync on green.	Turn off sync on green (page 2-6).
The image is too soft.	The detail level needs to be changed.	Change the detail level (page 2-6).

Troubleshooting, cont'd



DVS 150

A

Appendix

Reference Information

Specifications

Part Numbers

Reference Information

Specifications

Video input

Number/signal type	1 RGBHV, RGBS, RGsB pass-through 1 component video (Y, R-Y, B-Y) 1 S-video 1 composite video
Connectors	3 BNC female component video 1 4-pin mini-DIN female S-video 1 BNC female composite video 1 15-pin HD female RGB pass-through
Nominal level(s)	Analog 0.7V to 1.0V p-p
Impedance	75 ohms
Vertical frequency	50 Hz to 60 Hz (does not apply to pass-through)

Video output

Number/signal type	1 scaled RGBHV, RGBS, RGsB 1 scaled RGBHV or pass-through RGBHV/RGBS/RGsB
Connectors	6 BNC female 1 15-pin HD female
Nominal level	0.7V p-p
Impedance	75 ohms
Vertical frequency	56 Hz, 60 Hz, or 75 Hz
Scaled VGA resolution	640x480, 800x600, 832x624, 840x480, 852x480, 1024x768, 1280x768, 1280x1024, 1360x765, HDTV 480P, 720P, and 1080P

Sync

Input type	RGBHV, RGBS, RGsB
Output type	RGBHV, RGBS, RGsB
Standards	NTSC 3.58, NTSC 4.43, PAL, SECAM
Output level	TTL 5.0V p-p
Output impedance	75 ohms
Polarity	Positive or negative (switch-selectable)

Control/remote — decoder/scaler

Serial control port	RS-232, 9-pin female D connector
Baud rate and protocol	9600, 8-bit, 1 stop bit, no parity
Pin configurations	1 = input 1 select 2 = TX 3 = RX 4 = input 2 select 5 = GND 6 = input 3 select 7 = input 4 select
Contact closure	9-pin female D connector (same as RS-232 connector)
Contact closure pin configuration ...	See pins 1, 4, 6, and 7 above
Program control	Extron's control program for Windows® Extron's SIS™ (Simple Instruction Set™)

General

Power	100VAC to 240VAC, 50/60 Hz, 30 Watts, internal, auto-switchable
Temperature/humidity	Storage -40° to +158°F (-40° to +70°C) / 10% to 90%, non-condensing Operating +32° to +122°F (0° to +50°C) / 10% to 90%, non-condensing

Rack mount	Yes, with optional rack shelf, part #60-190-01
Enclosure type	Metal
Enclosure dimensions	1.75" H x 8.75" W x 9.50" D 4.45 cm H x 22.22 cm W x 24.13 cm D
Shipping weight	6 lbs (2.7 kg)
Vibration	NSTA 1A in carton (National Safe Transit Association)
Approvals	UL, CUL, CE, FCC Class B
MTBF	30,000 hours
Warranty	2 years parts and labor

NOTE Specifications are subject to change without notice.

Part Numbers

DVS 150 part numbers

Extron Part	Part #
DVS 150	60-317-01
Signal Enhancement Products Control Program	29-017-01
DVS 150 User's Manual	68-459-01
S-video cable, 6'	26-316-02

Related part numbers

Extron Part	Part #
Universal rack shelf	60-190-01

BNC cables

Extron SHR BNC cables are super high resolution cables. Extron recommends using high-resolution BNC cables for signals with scan frequencies of 15 — 125 kHz to achieve maximum performance.

Bulk cable

Extron Part	Part #
Super High Resolution Cable	
Bulk SHR-1, 500'	22-098-02
Bulk SHR-1, 1000'	22-098-03
Bulk SHR-4, 500'	22-099-02
Bulk SHR-5, 500'	22-100-02
BNC SHR crimp connectors, qty. 50	100-075-51
BNC-4 Mini HR Cable	
Bulk BNC-4-500' HR	22-032-02
Bulk BNC-4-1000' HR	22-032-03
BNC-5 Mini HR Cable	
Bulk BNC-5-500' HR	22-020-02
Bulk BNC-5-1000' HR	22-020-03
Plenum BNC-5 Mini HR Cable	
Bulk BNC-5-500' HRP	22-103-02
Bulk BNC-5-1000' HRP	22-103-03
Plenum Install Cable	
Bulk Plenum Install, 500'	22-111-03
Bulk Plenum Install, 1000'	22-111-04

NOTE Bulk cable in lengths up to 5000' rolls is available with or without connectors.

Reference Information, cont'd

Assorted connectors

BNC Connectors

BNC Mini HR crimp connectors, qty. 50	100-074-51
BNC SHR crimp connectors, qty. 50	100-075-51
BNC Bulkhead connectors, qty. 50 (for custom wall plates)	100-076-51

Pre-cut cables

BNC-4 HR cable is used for RGBS cable runs, and BNC-5 is used for RGBHV cable runs. Either type can also be used for RGsB (sync on green). All Extron BNC cables have male gender connectors at both ends. A plenum version of the BNC-5 HR cable is also available.

BNC-4 HR Cable

BNC-4-25' HR (25 feet/7.5 meters)	26-210-04
BNC-4-50' HR (50 feet/15.0 meters)	26-210-05
BNC-4-75' HR (75 feet/23.0 meters)	26-210-06
BNC-4-100' HR (100 feet/30.0 meters)	26-210-07
BNC-4-150' HR (150 feet/45.0 meters)	26-210-08
BNC-4-200' HR (200 feet/60.0 meters)	26-210-09
BNC-4-250' HR (250 feet/75.0 meters)	26-210-54
BNC-4-300' HR (300 feet/90.0 meters)	26-210-53

BNC-5 HR Cable

BNC-5-25' HR (25 feet/7.5 meters)	26-260-03
BNC-5-50' HR (50 feet/15.0 meters)	26-260-04
BNC-5-75' HR (75 feet/23.0 meters)	26-260-16
BNC-5-100' HR (100 feet/30.0 meters)	26-260-05
BNC-5-150' HR (150 feet/45.0 meters)	26-260-12
BNC-5-200' HR (200 feet/60.0 meters)	26-260-06
BNC-5-250' HR (250 feet/75.0 meters)	26-260-18
BNC-5-300' HR (300 feet/90.0 meters)	26-260-14

FCC Class B Notice

This equipment has been tested and found to comply with the limits for a Class B digital device, pursuant to part 15 of the FCC Rules. These limits are designed to provide reasonable protection against harmful interference in a residential installation. This equipment generates, uses and can radiate radio frequency energy and, if not installed and used in accordance with the instructions, may cause harmful interference to radio communications. However, there is no guarantee that the interference will not occur in a particular installation. If this equipment does cause harmful interference to radio or television reception, which can be determined by turning the equipment off and on, the user is encouraged to try to correct the interference by one or more of the following measures:

- Reorient or relocate the receiving antenna.
- Increase the separation between the equipment and receiver.
- Connect the equipment into an outlet on a circuit different from that to which the receiver is connected.
- Consult the dealer or an experienced radio/TV technician for help.

This unit was tested with shielded cables on the peripheral devices. Shielded cables must be used with the unit to ensure compliance.

Extron's Warranty

Extron Electronics warrants this product against defects in materials and workmanship for a period of two years from the date of purchase. In the event of malfunction during the warranty period attributable directly to faulty workmanship and/or materials, Extron Electronics will, at its option, repair or replace said products or components, to whatever extent it shall deem necessary to restore said product to proper operating condition, provided that it is returned within the warranty period, with proof of purchase and description of malfunction to:

USA, Canada, South America, and Central America:

Extron Electronics
1230 South Lewis Street
Anaheim, CA 92805
United States of America

Europe, Africa, and the Middle East:

Extron Electronics, Europe
Beeldschermweg 6C
3821 AH Amersfoort
The Netherlands

Asia:

Extron Electronics, Asia
135 Joo Seng Road, #04-01
PM Industrial Building
Singapore 368363

This Limited Warranty does not apply if the fault has been caused by misuse, improper handling care, electrical or mechanical abuse, abnormal operating conditions or non-Extron authorized modification to the product.

If it has been determined that the product is defective, please call Extron and ask for an Applications Engineer at (714) 491-1500 (USA), 31.33.453.4040 (Europe), or 65.383.4400 (Asia) to receive an RA# (Return Authorization number). This will begin the repair process as quickly as possible.

Units must be returned insured, with shipping charges prepaid. If not insured, you assume the risk of loss or damage during shipment. Returned units must include the serial number and a description of the problem, as well as the name of the person to contact in case there are any questions.

Extron Electronics makes no further warranties either expressed or implied with respect to the product and its quality, performance, merchantability, or fitness for any particular use. In no event will Extron Electronics be liable for direct, indirect, or consequential damages resulting from any defect in this product even if Extron Electronics has been advised of such damage.

Please note that laws vary from state to state and country to country, and that some provisions of this warranty may not apply to you.



EXTRON ELECTRONICS/RGB SYSTEMS, INC.
1230 South Lewis Street, Anaheim, CA 92805
800.633.9876 714.491.1500 FAX 714.491.1517
U.S.A.

EXTRON ELECTRONICS, EUROPE
Beeldschermweg 6C, 3821 AH Amersfoort
+31.33.453.4040 FAX +31.33.453.4050
The Netherlands

EXTRON ELECTRONICS, ASIA
135 Joo Seng Rd. #04-01, PM Industrial Bldg.
+65.383.4400 FAX +65.383.4664
Singapore 368363

EXTRON ELECTRONICS INFORMATION
EXTRONWEB™: www.extron.com
EXTRONFAX™: 714.491.0192
24-hour access—worldwide!