

bryant

day
night

Payne

installation instructions

HORIZONTAL GAS-FIRED FORCED-AIR FURNACE

349F
 Series A
 Sizes 050
 thru 140

Automatic Intermittent Ignition Pilot

Cancels: 39349DP12-A

39349DP14-A
4/1/85**CAUTION**

These instructions are intended to be used by qualified personnel who have been trained in installing this type of furnace. Installation of this furnace by an unqualified person may lead to equipment damage and/or a hazardous condition which may lead to bodily harm.

GENERAL INSTRUCTIONS

This furnace is designed for use with either natural or liquefied petroleum gases (propane) and has been design certified by the American Gas Association. It is shipped as a packaged unit, complete with burners and controls, and requires a line voltage (115V) connection to the junction box, a thermostat hook-up as per the wiring diagram and a gas line connection. The design of the furnace is such that the burners, controls and flue outlet can be assembled on the same side to facilitate servicing for installations where only limited access to the unit is available. (See Assembly and Field Reversing)

This furnace has been designed to interface with split system cooling equipment (approved by U.L.) so as to provide "year-round air conditioning". The blower has been sized for both heating and cooling. Refer to table Fig. 13 which gives air flow data:

The furnace installation must conform with local building codes or, in the absence of local codes, with the National Fuel Gas Code, ANSI Z223.1-1984 (NFPA-54).

For complete information on installation standards consult the National Fuel Gas Code obtainable at a nominal cost from the National Fire Protection Association, Inc., Batterymarch Park, Quincy, MA 02269 or the American Gas Association, 1515 Wilson Boulevard, Arlington, VA 22209.

WARNING

The furnace cabinet must have an uninterrupted or unbroken electrical ground to minimize personal injury if an electrical fault should occur. The unit must also be electrically grounded in accordance with local codes, or in the absence of local codes, with the National Electrical Codes ANSI/NFPA No. 70-1981 or the latest edition. **DO NOT** use gas piping as an electrical ground.

LOCATION**Site Selection:**

This furnace may be located in an attic, basement crawl space, alcove or suspended from the ceiling of a utility room or basement. The following minimum clearances or greater, must be provided between the furnace and adjacent construction:

ATTIC/ALCOVE CLEARANCES				
TOP	SIDES	BACK	DRAFTHOOD	SINGLE WALL VENT
8"	6"	*	6"	6"

*8" with drafthood on front of furnace
 18" with drafthood on back of furnace

WARNING

Failure to comply with all of the above clearances will create a fire hazard.

If a furnace is to be installed in a residential garage, it must be installed so the burners and the ignition source are located not less than 18" above the floor and the furnace must be located or protected to avoid physical damage by vehicles.

The furnace should be located as close to the chimney as possible in order to keep vent connections as short and direct as possible. The furnace should also be located as near to the center of the air distribution system as possible, and should be installed level.

**FILE
COPY**

Since this furnace is suitable for attic installation, it may be installed on combustible wood flooring (It must not be installed directly on carpeting, tile or other combustible material). Line contact is only permissible between lines formed by the intersection of the furnace top and two sides and the building joists, studs or framing (see Fig. 1).

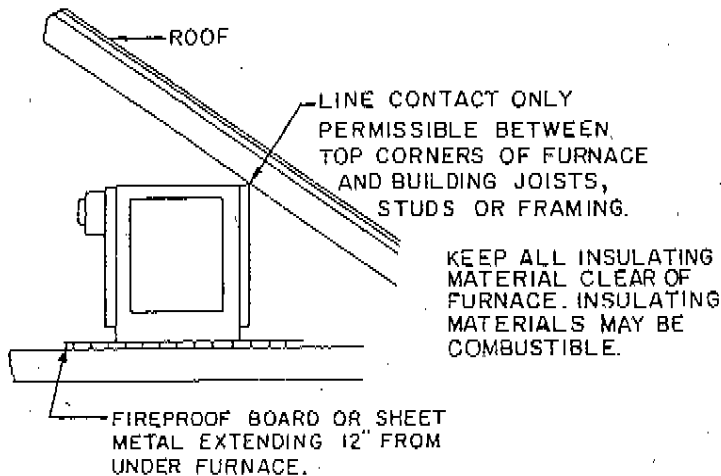

ATTIC INSTALLATION SHOWING POINT CONTACT
FIG. 1

A clearance of at least 30" should be provided at the front of the unit for combustion air and servicing.

For attic installations the passageway and servicing area adjacent to the furnace should be floored. The areas adjacent to the combustion air openings must be covered with fireproof board or sheet metal extending a minimum of 12" from the furnace (see Fig. 1).

If the furnace is to be installed in a crawl space, consult local codes (use of a concrete pad 1" to 2" thick is recommended).

If the furnace is to be suspended from the ceiling, it will be necessary to use steel pipe straps around each end of the furnace. These straps should be attached to the furnace with sheet metal screws and to the rafters with bolts. The furnace could also be suspended by an angle iron frame bolted to the rafters.

BTU INPUT	LENGTH	WIDTH	HEIGHT	WEIGHT
50,000	54	13 1/2	23 1/8	130
75,000	54	13 1/2	23 1/8	140
100,000	54	17	23 1/8	165
125,000	56	20 1/2	23 1/8	200
140,000	56	24	23 1/8	215

WARNING

Do not place combustible material on or against the drafthood or on the furnace jacket within 6" of the drafthood.

WARNING

This furnace is not watertight and is not designated for outdoor installation.

Air for Combustion and Ventilation:

Adequate facilities for providing air for combustion and ventilation must be provided.

For an unconfined space (more than 50 cu. ft. of volume per 1,000 BTU of aggregate input rating of all appliances installed in that space) such as a basement or attic, infiltration air is normally adequate to provide air for combustion, ventilation and dilution of flue gases. Adjoining rooms may be included if there are no doors between the rooms.

For a confined space, where air is taken from an interior space, two permanent openings of equal area are required. One opening must be within 12" of the ceiling and the other within 12" of the floor.

Each opening must have a free area of at least 1 sq. in. per 1000 BTU of total input rating but not less than 100 sq. inches.

If outside air is supplied to a confined space, then the two openings must be equal and located as above and the free area of each must be:

1. 1 sq. in. per 4,000 BTU of total input rating when the air is directly communicated from the outdoors.
2. 1 sq. in. per 4,000 BTU of total input rating when the air is brought in through vertical ducts.
3. 1 sq. in. per 2,000 BTU of total input rating when the air is transferred through horizontal ducts.

CAUTION

Whenever this furnace is installed in an area along with one or more gas appliances, the total BTU input of all appliances must be included when determining the free area requirements for combustion and ventilation air openings.

When ducts are used, they must be of the same cross-sectional area as the free area of the openings to which they connect.

The minimum dimension of rectangular air ducts must not be less than 3 inches.

The free area through a design of louver or grille should be used in calculating the size opening required to provide the free area specified. If the design and free area is not known, it may be assumed that wood louvers will have 20-25% free area and metal louvers and grills will have 60-75% free area. Screens used must not be smaller than 1/4" mesh and louvers shall be fixed in the open position or interlocked with the equipment so that they are opened automatically during equipment operation.

WARNING

Do not block the combustion air openings in the furnace. Any blockage will result in improper combustion and may result in a fire hazard or unsafe condition.

CAUTION

For an attic installation it is important to keep insulation 12" or more away from any furnace openings. Some types of insulating materials may be combustible.

ASSEMBLY

The burner and controls are shipped in place and the furnace's high and low voltage wiring has been completed to facilitate the installation. Low voltage wiring to the field supplied thermostat is necessary to complete the unit's wiring (See Electrical Section).

In order to accommodate all the field installations that may exist, the unit has been designed so that the gas valve, controls and draft hood assembly may be assembled on either side of the furnace.

Please refer to the section "FIELD REVERSING" for specific details on how to accomplish this. If reversing is desired, skip to that section before proceeding.

CAUTION

Remove cardboard shipping insert from eye of the blower scroll before energizing blower.

DRAFTHOOD:

In order to save shipping space the draft hood is shipped disassembled (on models 125 and 140 the left cheek will be spotwelded in place). Remove the draft hood components from the blower compartment (on some models the cheeks might be packed outside the furnace jacket). On the models 50, 75 and 100 there will be a wrapper, two cheeks (one marked with "R", the other marked with "L") and a hardware package.

Refer to Figure 2 for assembling the draft hood. Depending on the model, one or both cheeks will need to be slid into the proper location in order to line up the four (4) mounting holes. Secure the cheek(s) with the screws provided.

Upon completion of the draft hood assembly, it is advisable to check the overall size with the table below:

BTU INPUT	LENGTH	HEIGHT	DEPTH	PIPE DIA.
50,000	16"	10"	8"	4"
75,000	16"	10"	8"	4"
100,000	16"	10"	8"	5"
125,000	17 1/4"	10"	8"	5"
140,000	17 1/4"	10"	8"	6"

Install the draft hood over the selected flue opening by placing it on top of the draft hood clip and securing it to the furnace jacket with the screws provided. Make sure the necessary clearances, located on page 1, are held.

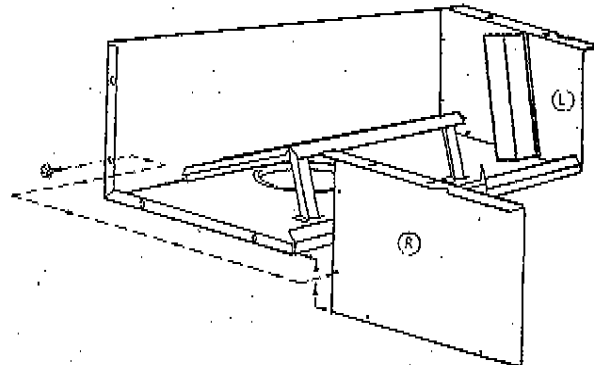

NOTE: Cheek "L" (left hand cheek) will be spotwelded in location on models 125 and 140.

FIG. 2

INSTALLATION

Ductwork Recommendations:

The proper sizing of warm air ducts is necessary to insure satisfactory heating operation. Ductwork should be in accordance with the latest editions of NFPA-90A (Air Conditioning Systems) and NFPA-90B (Warm Air Heating and Air Conditioning Systems).

The following recommendations should be followed when installing the ductwork:

1. Install locking-type dampers in all branches or the individual ducts to balance out the system. Dampers should be adjusted to impose the proper static at the outlet of the furnace.
2. Noncombustible flexible duct connectors are recommended to connect both the supply and return ducts to the furnace.
3. In cases where the return air grille is located close to the fan inlet, there should be at least one 90 degree air turn between fan and inlet grille. Further reduction in sound can be accomplished by installing acoustical air turning vanes and/or lining the inside of the duct with acoustical material.

CAUTION

Air openings in the burner cover, return air grilles, and warm air registers must not be obstructed.

WARNING

When supply ducts carry air circulated by the furnace to areas outside the spaces containing the furnace, the return air shall also be handled by a duct sealed to the furnace casing and terminating outside the space containing the furnace.

When installing the furnace with cooling equipment for year-round operation, the following recommendations must be followed for series or parallel air flow:

1. In series air flow applications, the coil is mounted after the furnace in an enclosure in the supply air stream. The furnace blower is used for both heating and cooling air flow.

WARNING

The coil **MUST** be installed on the air discharge side of the furnace. Under no circumstances should the air flow be such that cooled, conditioned air can pass over the furnace heat exchanger. This will cause condensation in the heat exchanger and early failure from rust.

2. In parallel flow installation, dampers must be provided to direct air over the furnace heat exchanger when heat is desired and over the cooling coil when cooling is desired.

IMPORTANT: The dampers should be adequate to prevent cooled air from entering the furnace, and if manually operated, must be equipped with means to prevent operation of either the cooling unit or furnace unless the damper is in the full cool or heat position.

Venting Instructions:

Venting of this furnace must be to the outside and in accordance with local codes or requirements of the local utility. In the absence of local codes, venting must conform to the requirements of the National Fuel Gas Code (NFPA 54-1984/ANSI Z223.1-1984) Part 7.

For additional venting information refer to ANSI/NFPA 211 Chimneys, Fireplaces, Vents, and Solid Fuel Burning Appliances.

Masonry Chimney:

This furnace can be vented into an existing masonry chimney. This furnace must not be vented into a solid fuel burning chimney. Before venting this furnace into a chimney, the chimney must be checked for deterioration and repaired if necessary. The chimney must be properly lined and sized per the National Fuel Gas Code.

Normal connections to a chimney are made using single wall pipe, however, single wall pipe is not approved to pass through any attic, inside wall or concealed space or through any floor (For further information consult venting section of National Fuel Gas Code).

Type "B-1" Vent:

The furnace is also approved for use with a "B1" vent that terminates through the roof (horizontal venting through an outside wall is not approved). The vent must be

terminated with a listed cap or roof assembly. This venting must be installed in accordance with the vent manufacturer's instructions and be in accordance with all local codes and/or the National Fuel Gas Code.

Attic Installation:

For attic installations it is required to use Type B or Type L vent material.

The following requirements are provided for a safe venting system:

1. Be sure that the chimney flue is clear of any dirt or debris.
2. Be sure that the chimney is not serving an open fireplace.
3. Never reduce the pipe size below the outlet size of the furnace.
4. All pipe should be supported using the proper clamps and/or straps.
5. All horizontal runs of pipe must have a 1/4" per foot of upward slope.
6. All runs of pipe must be as short as possible with as few turns as possible.
7. Seams must be tightly joined and checked for leaks.
8. The flue pipe must not extend into the chimney but be flush with the inside wall.
9. The chimney or gas vent must extend three feet above the highest point where it passes through a roof of a building and at least two feet higher than any portion of a building within a horizontal distance of ten feet. It shall also extend at least five feet above the highest connected equipment flue collar.
10. Check local codes for any variance.

Burner Orificing:

The furnace is supplied with standard orifices for the gas shown on the rating plate. Figure 3 shows combinations of heating values and specific gravities for various gases, from which proper input can be obtained.

Regardless of the type of gas used, when installation is at an elevation of 2000 ft. or more above sea level, orifices may need to be changed, depending on local gas values. For operation at elevations above 2000 ft., input ratings should be reduced at the rates of four percent (4%) for each 1000 ft. above sea level.

To change orifices, remove the burner removal cover on the gas valve side of the

furnace. Remove manifold locking screw(s) and slide the manifold tray towards the inlet end of the unit. When each burner is clear of the heat exchanger, pull the manifold tray towards the front of the unit until the last burner is clear of the furnace and place the tray down on a flat surface. Remove the two screws holding the burner assembly to the manifold and slide the burner assembly back off the orifices.

CAUTION

Care must be taken when removing the pilot burner in order not to damage the pilot gas line.

Type of Gas (Heating Value-Sp Gr.) BTU per CU. FT.	Orifice Size (Drill No.)
Natural-Manif. Pr. 3.5" W.C.	
800-0.6	40
900-0.6	41
1000-0.6	42
1100-0.6	43
Propane-Manif. Pr. 10" W.C.	
2500-1.53	54

FIG. 3

After removing the orifices, make sure that the new orifices are seated properly and tightened. Replace the burner assembly over the orifices and secure with the two screws removed previously. Slide the manifold tray back into the heat exchanger tubes and secure with the locking screw on the front side only.

CAUTION

The manifold must be properly positioned in order for locking screw to engage.

After securing the manifold assembly, replace all other components and/or wiring, being sure that all connections and screws are tightened properly.

WARNING

If it is necessary to adjust the manifold pressure more than ± 0.3 " w.c., then the orifices must be changed.

WARNING

Never set the furnace input rate above that shown on the rating plate.

Use the following formula to determine the furnace's input rate;

Input = Heating Value Gas (BTU/cu. ft.)
(BTU/hr) x 7200 sec/2 hr + time in
seconds for 2 cu. ft. of gas.

Example: If the heating value of natural
gas is 1015 BTU/cu. ft. and it takes 75
sec. to burn 2 cu. ft. of gas, then:

$$\text{Input} = \frac{1015 \text{ BTU/cu. ft.} \times 7200 \text{ sec/2 hr}}{75 \text{ sec/2 cu. ft.}} \text{ (BTU/hr)}$$

Input = 97,440 BTU/hr

When checking rate, make sure all other
gas appliances are shut off except for
pilot burners.

Gas Piping:

Gas piping shall be of such size and so
installed as to provide a supply of gas
sufficient to meet the maximum demand
without undue loss of pressure between
the gas meter and the furnace. It is re-
commended that the gas line to the fur-
nace shall be a separate line direct from
the meter, unless the existing gas line
is of ample capacity. Refer to Fig. 4 for
sizing the gas piping.

Use a joint compound (pipe dope) that
is resistant to the action of liquefied
petroleum gases or to any other chemical
constituents of the gases to be conducted
through the piping.

CAPACITY IN CU. FT. OF GAS PER HOUR					
Length of Pipe in feet	Diameter of Pipe-IPS (in inches)				
	1/2	3/4	1	1-1/4	1-1/2
10	132	278	520	1050	1600
20	92	190	350	730	1100
30	73	152	285	590	890
40	63	130	245	500	760
50	--	115	215	440	670
75	--	93	175	360	545
100	--	79	150	305	460
150	--	64	120	250	380

Based on gas pressures of 0.5 PSIG or less and pressure drop of 0.3" WC and 0.60 specific gravity gas.

GAS PIPE CAPACITY TABLE

FIG. 4

Before any system of gas piping is fin-
ally put into service, it should be care-
fully tested to determine if it is gas tight.
The piping must stand a pressure of six
inches of mercury for a period of ten
minutes or as required by local authority.

WARNING
The furnace and its individual shutoff
valve must be disconnected from the gas
supply piping system during any pressure
testing of that system at test pressures in
excess of 1/2 PSIG (14"wc).

The furnace must be isolated from the
gas supply piping system by closing its
individual manual shutoff valve during
any pressure testing of the gas supply
piping system at pressures equal to or
less than 1/2 PSIG (14"wc).

The recommended method for installing the
gas piping to the furnace is shown in Fig. 5.
Fig. 6 shows the correct piping for the fur-
nace if the gas valve and controls have been
reversed. (See FIELD REVERSING)

Support all gas piping independent of the
unit.

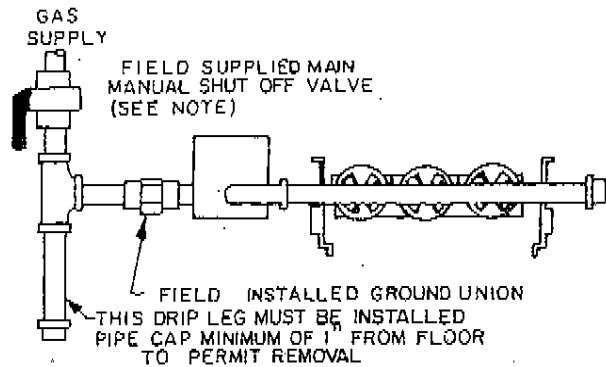

GAS PIPE LAYOUT

FIG. 5

NOTE:

LOCATE MANUAL CONTROL VALVE AS
REQUIRED BY THE LOCAL AUTHORITY OR
CODE. IN THE ABSENCE OF SUCH A
CODE, LOCATE THE MANUAL MAIN
SHUTOFF VALVE AT 5 1/2 FT. FROM
THE FLOOR.

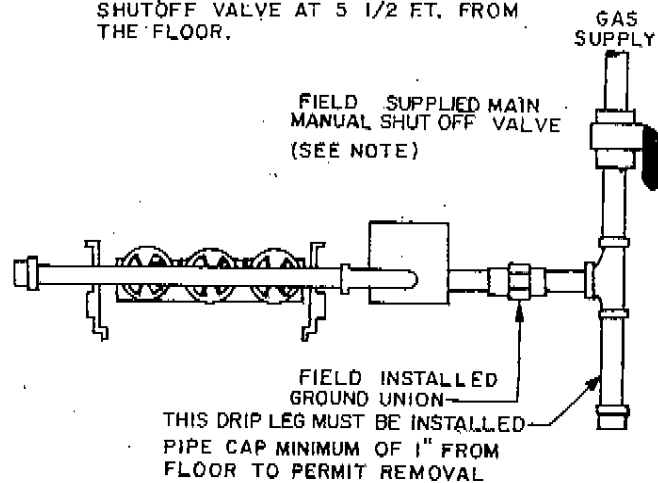

GAS PIPE LAYOUT

FIG. 6

For LP (propane) gas, a tank regulator required to reduce supply pressure to 12"-13" W.C. For manifold pressure see Fig. 3.

Check all piping for leaks using soapy water and a brush.

CAUTION

Never use an open flame when testing for gas leaks!

A 1/8 inch NPT plugged tap accessible for test gauge connection must be installed immediately upstream of the gas supply connection to the furnace if on is not supplied on the gas valve.

Electrical:

The control system depends on the correct polarity of the power supply. Connect "hot" wire (H) and "ground" wire (G) as shown in Fig. 14 and Fig. 15.

WARNING

The unit cabinet must have an uninterrupted or unbroken electrical ground to minimize personal injury if an electrical fault should occur.

Use copper wire only for 115V supply service to unit.

When replacing any original wiring, use only 105 degree C, 16 GA. AWG. copper wire.

Instructions for wiring the thermostat are packed in the thermostat (field supplied) box. Make the thermostat connections as shown in Fig. 14 or 15 at the 24 volt terminal board located on the electrical junction box.

When installing optional accessories to this appliance, follow the manufacturer's installation instructions included with the accessory. Other than wiring for the thermostat, a minimum of type T (63°F rise) must be used.

Filters:

Filters and racks are supplied as optional equipment. See Fig. 7 for recommended filter size rating and type. The filter rack assembly is outlined in Fig. 7.

IMPORTANT: All furnaces must be equipped with a filter.

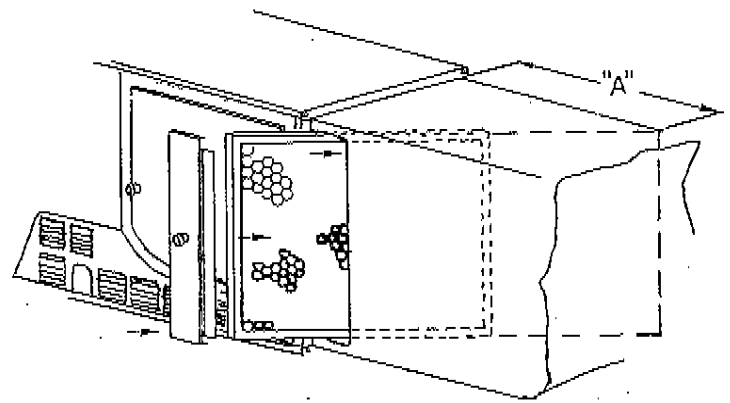

B.T.U. INPUT	A
50,000	14 1/2
75,000	
100,000	16 3/4
125,000	20 1/4
140,000	15 5/8

High velocity type filter required

NOTE:

FILTER RACK TO BE INSTALLED AT INLET END OF FURNACE IN RETURN DUCT WORK.

FILTER RACK ASSEMBLY
FIG. 7

FIELD REVERSING

WARNING

Before proceeding with the field reversing, be sure that a correct wiring diagram is available and/or be prepared to mark all wiring as it is disconnected.

The gas valve, pilot burner components, and controls may be reversed as follows (Note: this procedure applies to electronic ignition models only):

1. Loosen the burner removal cover screws and remove both covers.
2. Disconnect all wires to the gas valve and unplug the ignitor cable from the ignition control.
3. Remove the manifold assembly locking screw and slide the burner and manifold assembly back towards the furnace inlet until the burners are clear of the heat exchanger tubes.
4. Slide manifold assembly towards the front of the furnace until it is clear of the blower deck. NOTE: Keep the manifold assembly straight while removing. If the manifold is cocked, then the assembly will bind in the burner box.

5. Place manifold on a work area and disconnect the pilot tubing and thermocouple from the valve.
6. Using two pipe wrenches (one on the gas valve and one on the manifold extension pipe) remove the gas valve.
7. Remove the manifold extension pipe from the manifold (It may be necessary to put a pipe wrench on the manifold pipe while turning the extension).
8. Using two pipe wrenches (one on the manifold pipe between the pipe cap and burner orifices and one on the pipe cap) remove the pipe cap.
9. Clean the threads on the manifold pipes, gas valve and pipe cap of any old joint compound.

NOTE: Use a joint compound (pipe dope) that is resistant to the action of liquefied petroleum gases or to any other chemical constituents of the gases to be conducted through the piping.

10. Using a joint compound on external threads (see note above) and two pipe wrenches, replace the manifold pipe extension where the pipe cap was. The pipe extension should be tightened and positioned so that it is pointing towards the back of the burners.
11. Using two pipe wrenches (one on the manifold extension and the other on the gas valve) tighten the gas valve onto the extension and position in the valve such that the manual knob is in the 12 o'clock position.
12. Using two pipe wrenches (one on the pipe cap and the other on the manifold pipe) tighten the pipe cap onto the other end of the manifold pipe.
13. Remove the screws holding the pilot bracket to the crossovers of the first two burners. When removing the pilot assembly, be careful not to damage the pilot gas tubing and the ignition cable.

NOTE: This step is not required for a Model 50, since there are only two burners.

14. With the pilot bracket removed from the burners, rebend the pilot tubing at the second bend as per Fig. 8. Make sure that there are no kinks in the tubing.

15. Mount the pilot bracket on the crossovers of the first two burners on the side of the manifold where the valve is now mounted (See Fig. 8).

16. Connect the 1/4" diameter pilot gas tubing to the gas valve. This will require adjustments to the pilot tubing and it is extremely important not to kink the aluminum tubing.

17. Check the pilot position per dimensions shown per Fig. 9.

18. Insert the manifold tray back into the furnace and slide the burners into the heat exchanger tubes. The locking screw will not engage unless the manifold is in the correct position.

19. Be sure that the ignition cable or sensing lead are not pinched under the burners.

20. Lock the manifold in place.

21. Remove the junction box cover and disconnect the motor leads.

22. Remove the junction box.

IMPORTANT: Pull junction box straight out from furnace until fan and limit is clear of side panel.

23. Remove the two hole plugs from the back side of the furnace and mount the junction box to this side of the furnace. Make sure that the door interlock switch is kept towards the blower door when mounting the junction box.

NOTE: The fan and limit dial will be upside down when the junction box is properly reversed. This does not affect the operation of the fan and limit.

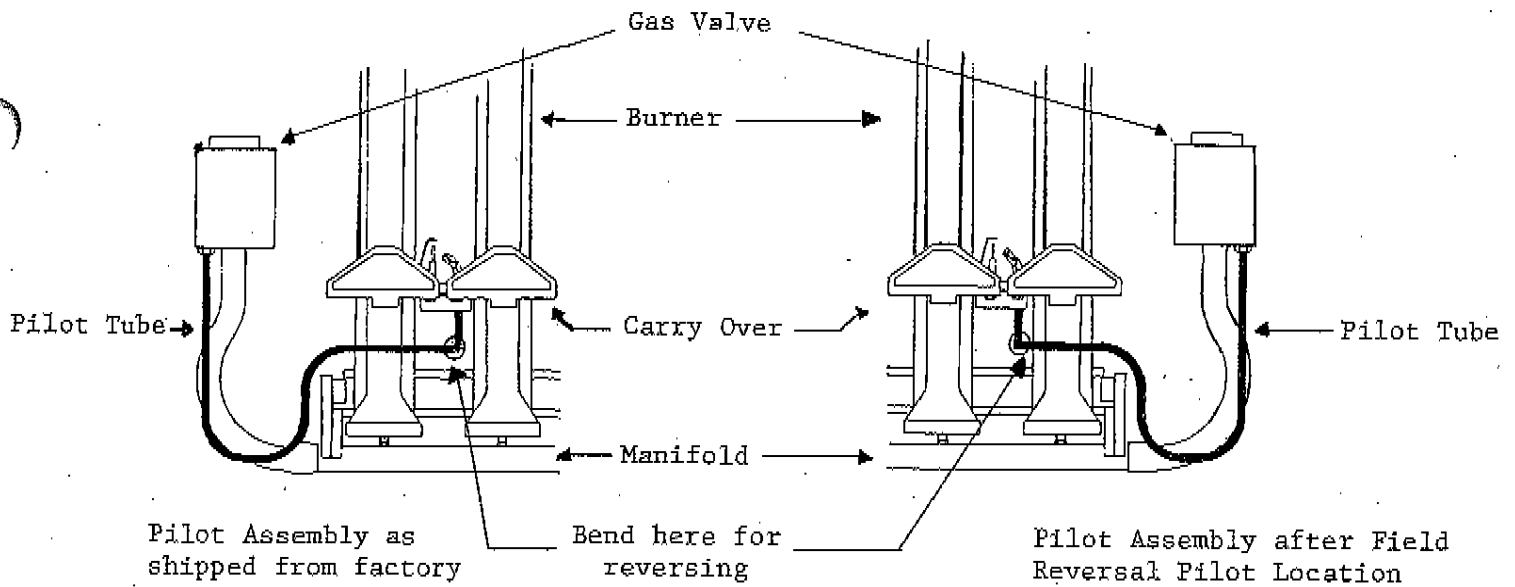
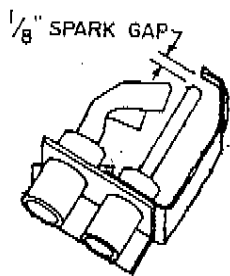

FIG. 8



EDGE OF PILOT HOOD TO BE FLUSH TO $\pm \frac{1}{16}$ WITH UPPER EDGE OF OPENING IN CROSSOVER SLOT.

.039 CROSSOVER SLOT.

SECTION A-A

DIMENSION FROM EDGE OF CROSSOVER FLUSH WITH CORNERPOINT OF PILOT.

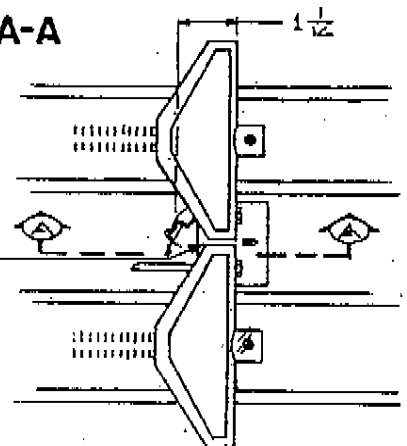

PILOT LOCATION

FIG. 9

24. Remove the motor wires strain relief from the side panel, route the motor leads under the blower, feed the wires into the back of the junction box and snap the strain relief into place.
 25. Reconnect the motor leads and replace the junction box cover.
 26. Replace the hole plugs into the openings where the fan & limit and the motor leads were.
 27. Remove the drafthood and the drafthood support clip.
 28. Remove the flue box cover and the flue box cover gasket and remount them where the drafthood was located. Note: Do not glue gasket onto cover plate.
 29. Replace the drafthood support clip and the drafthood where the flue box cover plate was located.
- NOTE: All controls, wiring, drafthood and the AGA and lighting instruction plates must be located on the same side of the furnace as the automatic main gas valve.
30. Reattach all wires to the gas valve and the ignition cable to the ignition control. Check all wiring against the wiring diagram.
 31. After the furnace has been reversed, then go back to the "Drafthood" subsection and proceed.

Operational Checkout

General:

The automatic gas valve controls the flow of gas to both the pilot and main burners. The manual valve built into the automatic valve body has 2 positions: OFF and ON. It does not have an intermittent position for pilot gas flow only.

To turn on the gas manually prior to setting the system to automatic thermostatic control: Turn knob from OFF to ON position.

To shut off the gas manually: Turn knob from ON to OFF position. When in OFF

position, the main burners and the pilot flame are extinguished.

Here's How Your Heating System Works

The furnace operates automatically. It is controlled by a thermostat which you set at the temperature most comfortable to you. When the inside temperature drops below this setting, your thermostat senses this and turns on the system.

When the thermostat calls for heat, power from the transformer simultaneously energizes the pilot gas valve (inside the main gas valve) and the spark ignitor.

After the pilot flame is established, the electrode ceases to spark and the flame sensing probe acts to energize the main gas valve, permitting gas flow to the burners. A heat sensing switch will automatically turn on the blower when the heat build up is sufficient. The air moved by the blower over the heating element is warmed and goes through the ducts to the room registers.

When the thermostat is satisfied, the circuit is broken, de-energizing the main gas valve and stopping gas flow to both the pilot burner and main burners. The blower continues to run until the heat in the element is removed and then the heat sensing switch will shut down the blower.

The heat sensing fan switch also performs as the furnace high temperature limit switch. If the furnace overheats for any reason, the limit side of the fan and limit switch opens, breaking the circuit to the main gas valve. The blower motor will remain energized and as the unit cools, the limit switch will close. This will relight the main burners and unless the overheating condition is corrected, the furnace will cycle on limit.

WARNING

Should overheating occur, or the gas supply fail to shut off, shut off the manual gas valve to the appliance before shutting off the electrical supply.

This unit is equipped with either Honeywell S86E, S86F, S86G or S86H Intermittent pilot control.

S86E (& F) control: If the pilot fails to light, the pilot valve and spark gap remain energized until there is a successful ignition.

S86G (& H) control: If the pilot fails to light, the control will shut down the system. To initiate a re-ignition trial, turn down the thermostat to lowest setting, wait at least 60 seconds, and then reset thermostat to above room temperature.

Startup:

After the ductwork connections have been made, gas piping and electrical wiring completed, and the furnace has been properly vented, the unit should be started and adjusted for proper operation. Check off the following steps as they are completed:

1. Set the manual gas shut-off valve at the "OFF" position.
2. Be sure all electrical power is off.
3. Check all wiring using proper diagram on inside of blower door.
4. Set the thermostat above room temperature.
5. Turn on the power supply to the furnace. This energizes the pilot valve and the spark gap. The burners should NOT light.

For an S86E (or F) control the electrode will continue sparking. For an S86G (or H) control the electrode will cease sparking within seconds.

6. Turn dial on gas valve to "ON" position - the pilot should light. When the sensing probe detects the presence of pilot flame, the control de-energizes the spark gap and energizes the main gas valve. The main burners should light and remain on. (If system shuts down on S86G or H control a re-ignition trial will be necessary).
7. Check for leaks in the manual valve, gas control valve, and gas connections using a soap solution.

CAUTION

Never use an open flame when testing for gas leaks!

8. Leave burners on for 15 minutes before making a combustion adjustment.

Combustion Adjustment:

A primary air shutter assembly is provided on each burner. The shutters have

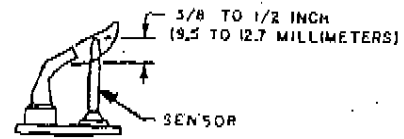
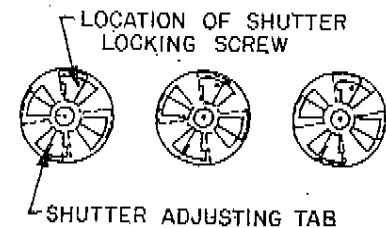

FIG. 10



NOTE:

LOOSEN LOCKING SCREW BEFORE ADJUSTING SHUTTER. RETIGHTEN SCREW AFTER FINAL ADJUSTMENTS ARE MADE.

FIG. 11

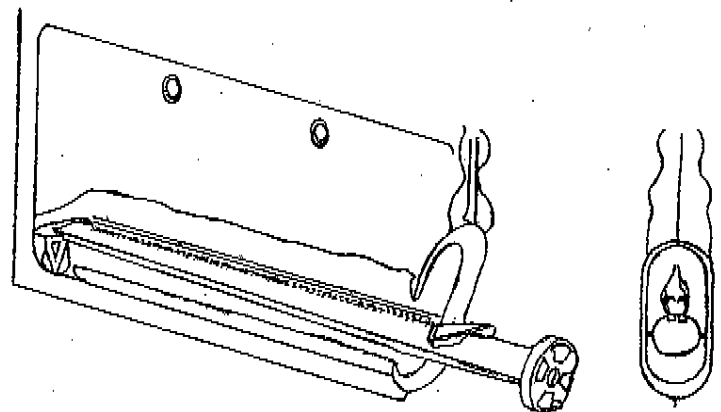

FIG. 12

been factory set for natural gas operation but readjustment may be required to obtain optimum setting. The shutters are individual to each burner so adjustment of the burner flame must be done one at a time (See Fig. 11).

Loosen the locking screw and close the air shutter. This should cause the burner flame to glow bright yellow. Open the shutter until the flame turns blue. Lock the locking screw. See Fig. 12 for proper flame. Repeat this procedure until all burners are adjusted properly.

A visual check of the main burner and pilot flame should be made at the beginning of each season. See Fig. 12 for proper flame.

Manifold Pressure Adjustment:

For natural gas, best results are obtained with a manifold pressure of 3.0" to 3.5" water column. Remove pressure tap pipe plug from the gas valve and connect to a water manometer. Measure gas pressure with the unit on.

Turn regulator adjusting screw in to increase pressure, out to decrease pressure as necessary. The input rate must be maintained $\pm 2\%$.

For LP gases (propane) a 10" wc pressure is necessary.

Fan Adjustment Check:

This furnace is equipped with a 2 or 3 speed direct drive motor to deliver a temperature rise within the range specified on the rating plate, between the return and supply plenums at the external duct static pressure noted on the AGA rating plate.

Adjust the fan speed so that the temperature rise is within the rise specified on the rating plate.

Consult the wiring diagram for speed changes on the direct drive motor.

Fan and Limit Control Check:

After the furnace has been in operation for at least 15 minutes, restrict the return air supply by blocking the filters or closing the return registers and allow the furnace to shut down on high limit. **THE FAN MUST CONTINUE TO RUN.** Remove the restriction and the burner should come on in a few minutes.

The operational checkout is now complete. Be sure to adjust the thermostat to the desired setting and inform the homeowner how to operate the furnace system before leaving the job site.

INPUT 1000 BTU/HR.	FAN MOTOR HP	BLOWER SIZE D X W	DIRECT DRIVE SPEED TAP & LEAD COLOR	BLOWER SPEED RPM	AIR FLOW cfm-E.S. In. Wc.			
					HEATING	COOLING		
					.20	.30	.40	.50
50	1/5	10 X 4	HIGH SPEED-BLACK	1060		945	905	860
	2 SPEED		LOW SPEED-RED	830	765			
50	1/4	10 X 4	HIGH SPEED-BLACK	1070		1045	995	930
	3 SPEED		LOW SPEED-RED	760	735			
50	1/3	10 X 6	HIGH SPEED-BLACK	1080		1340	1290	1220
	3 SPEED		LOW SPEED-RED	700	790			
75	1/5	10 x 6	HIGH SPEED-BLACK	920	1165			
75	1/4	10 x 6	HIGH SPEED-BLACK	1020		1220	1170	1130
	3 SPEED		MEDIUM SPEED-BLUE	790	995			
75	1/3	10 X 6	HIGH SPEED-BLACK	1060		1360	1310	1260
	3 SPEED		MEDIUM SPEED-BLUE	820	1090			
100	1/5	10 x 8	HIGH SPEED-BLACK	860	1310			
100	1/4	10 x 8	HIGH SPEED-BLACK	990		1390	1350	1290
	3 SPEED		MEDIUM SPEED-BLUE	730	1090			
100	1/3	10 x 8	HIGH SPEED-BLACK	1050		1645	1600	1530
	3 SPEED		MEDIUM SPEED-BLUE	840	1360			
125	1/3	10 x 10	HIGH SPEED-BLACK	1040		1750	1680	1590
	3 SPEED		MEDIUM SPEED-BLUE	830	1430			
125	1/2	12 x 9	HIGH SPEED-BLACK	1000		1960	1900	1840
	3 SPEED		MEDIUM SPEED-BLUE	820	1670			
125	3/4	12 x 9	HIGH SPEED-BLACK	1000		2220	2170	2115
	3 SPEED		MEDIUM SPEED-BLUE	920	1810			
140	1/2	10 x 10	HIGH SPEED-BLACK	1080		2030	1950	1865
	3 SPEED		MEDIUM SPEED-BLUE	980	1885			
140	3/4	12 x 12	HIGH SPEED-BLACK	980		2490	2430	2350
	3 SPEED		MEDIUM SPEED-BLUE	780	2100			

FURNACE BLOWER SPECIFICATIONS AND AIRFLOW DATA

FIG. 13

WARNING

When operating the furnace in the heating mode, the static pressure and the temperature rise (outlet air temperature minus room temperature) must be within those limits specified on the AGA rating plate.

WARNING

Turn off all gas and electrical power to furnace before performing any maintenance or service on unit. (Unless specific test requires gas and electrical supplies.) Failure to take this precaution may result in personal injury due to electrical shock or uncontrolled gas leakage.

HORIZONTAL GAS-FIRED FURNACES
With Electronic Ignition
Trouble Analysis Chart

SYMPTOM	CAUSE	REMEDY
Pilot will not light.	<p>No spark at electrode.</p> <p>Spark shorting out to main burner.</p> <p>No gas at pilot burner.</p>	<p>Check spark gap - refer to installation <u>instructions</u></p> <p>Check for moisture or dirt accumulation on electrode ceramic - clean ceramic <u>with cloth.</u></p> <p>Cracked ceramic - replace pilot <u>electrode assembly.</u></p> <p>Check for loose or broken wiring at and between electronic control control box and electrode. Replace <u>wire as necessary.</u></p> <p>Check fuse or circuit breaker for 115-<u>volt supply to furnace.</u></p> <p>Check 24-volt input to electronic control box. If you read 24 volts and above steps have been completed, re-<u>place electronic control box assembly.</u></p> <p>Realign electrode tip away from main burner but maintain spark gap to pilot <u>burner as noted above.</u></p> <p><u>Check to see if pilot valve is opening.</u></p> <p>Look for loose or broken wiring connections. If no deficiency is found, <u>replace valve assembly.</u></p>
Burners will not ignite.	<p>No 115-volt power to furnace.</p> <p>No 24-volt power to control circuit.</p> <p>Miswired or loose con- nections.</p> <p>No gas at main burners.</p> <p>Flame probe or con- necting lead is shorted or open.</p> <p>Dirty pilot - yellow flame.</p>	<p>Connect to power supply. Check fuse, <u>wiring,</u> or circuit breaker.</p> <p><u>Check transformer-replace.</u></p> <p>Check all wiring and wirenut <u>connections.</u></p> <p><u>Check to see if main valve is opening.</u></p> <p>Look for loose or broken wiring con- nections. If no deficiency is found, <u>replace valve assembly.</u></p> <p><u>Correct electrical shorting or open circuit.</u></p> <p>Clean pilot orifice.</p>

HORIZONTAL GAS-FIRED FURNACES
With Electronic Ignition
Trouble Analysis Chart

Page 2

SYMPTOM	CAUSE	REMEDY
<p>Inadequate heating.</p>	<p>Furnace undersized for application. Gas input to furnace too low.</p> <p>Limit switch cycles main burners.</p>	<p><u>Replace</u> with proper size furnace.</p> <p>Check gas pressure at manifold. Clock gas meter for input. If too low, increase manifold pressure, or replace <u>with</u> correct orifices.</p> <p>OFF setting of fan control set too <u>high</u> - reset.</p> <p>Dirty air filters - clean and re<u>in</u>-<u>stall</u>.</p> <p>Blower speed too low - use faster speed <u>tap</u>.</p> <p>Registers closed, restricted ductwork - <u>open</u> or remove restriction.</p> <p>Check heat anticipator setting on thermostat - readjust.</p>
<p>Aldehyde odors, (CO), sooting flame - floating flame.</p>	<p>Incomplete combustion-poor flame characteristics.</p>	<p>Air shutter on burners-closed-adjust to <u>soft</u> blue flame.</p> <p>Check all screws around flue outlets and burner compartment - tighten.</p> <p>LACK OF COMBUSTION AIR - see <u>instruc</u>-<u>tions</u>.</p> <p>Cracked heat exchanger - replace.</p> <p>Overfixed furnace - reduce input, or change orifices.</p> <p>Check vent for restriction - clean as required.</p>

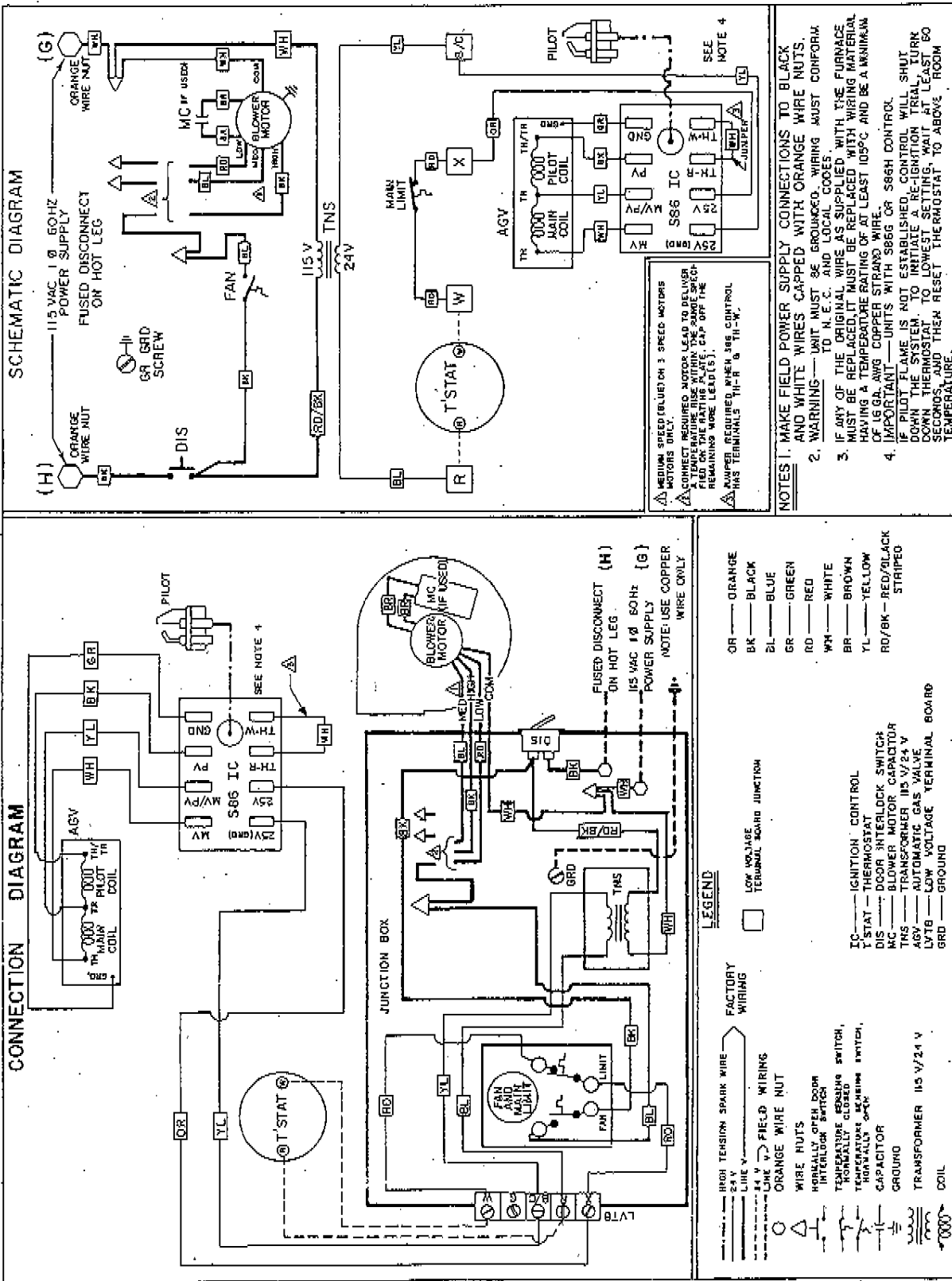

FIG. 14

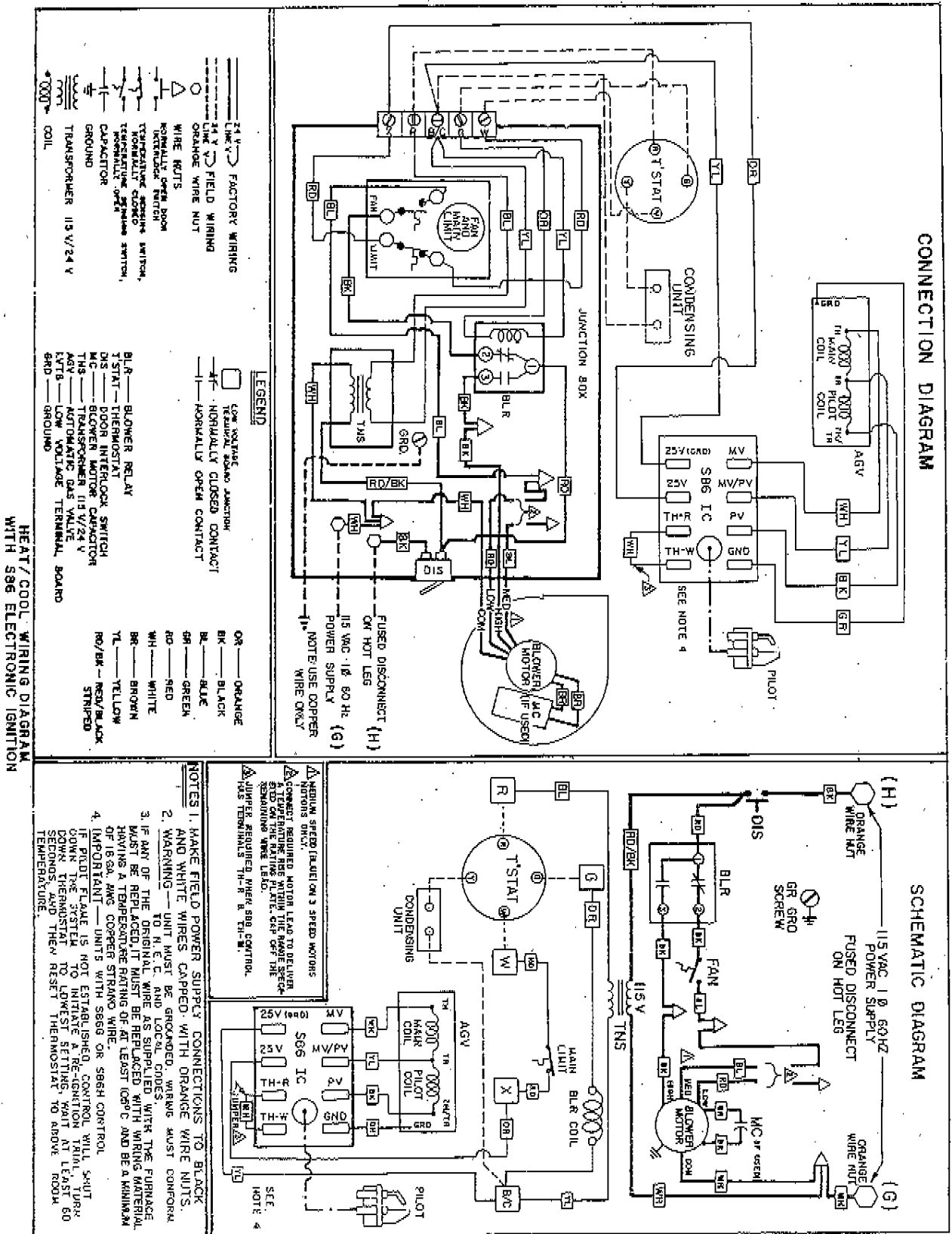
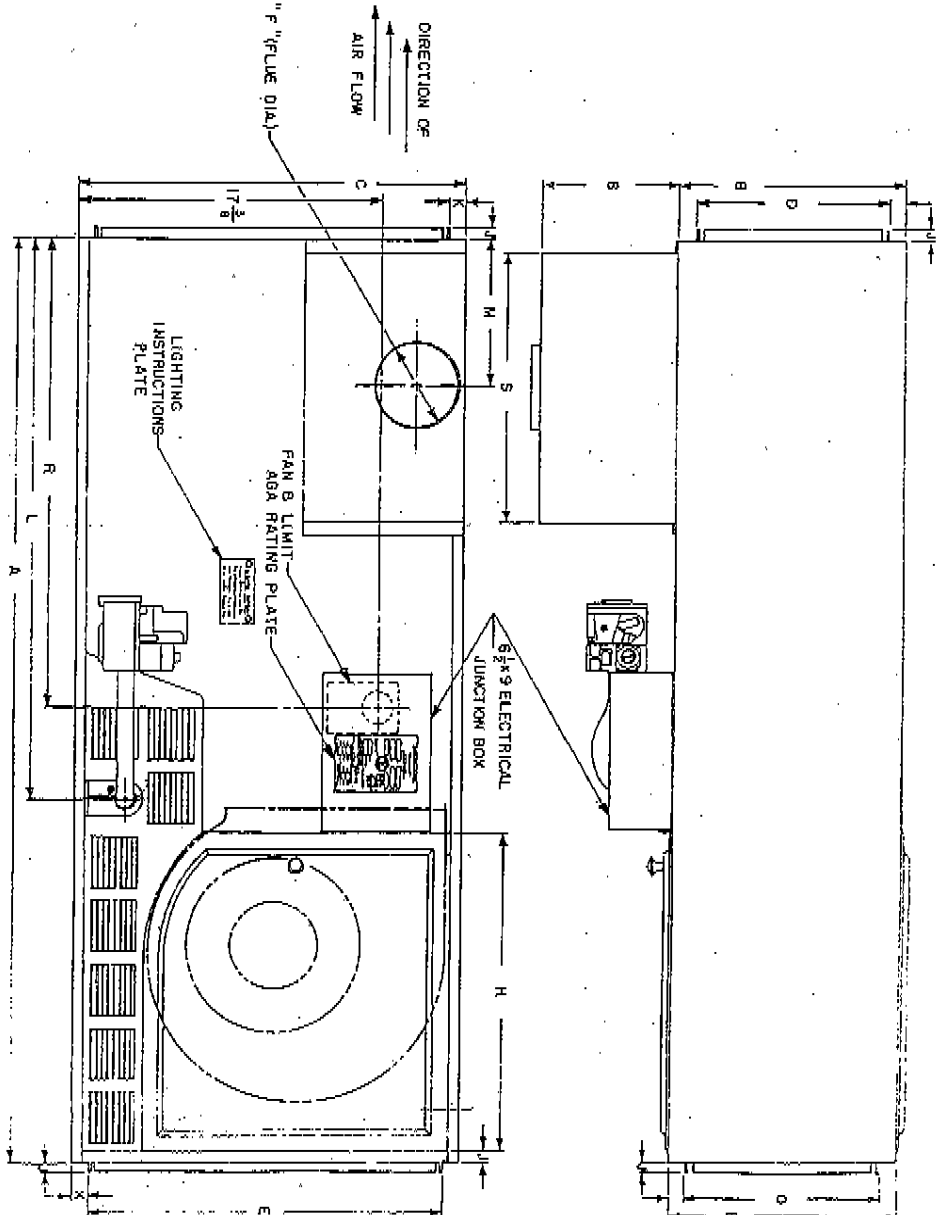
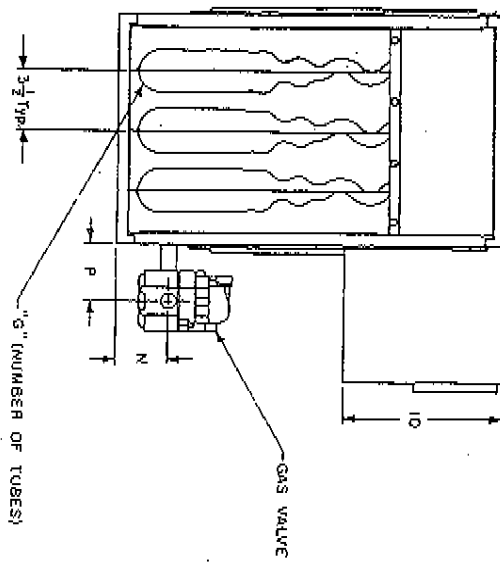

FIG. 15

ISSUED 8515
B8388 18-18

INPUT BTU./HR.	UNIT DIMENSIONS			DUCT SUPPLY AND RETURN OPENINGS		FLUE DIA.	FILTERS*										
	A	B	C	D	E		F	G	H	J	K	L	M	N	P	R	S
50,000	54	13 1/2	23 1/8	11 1/8	21 1/8	4	2	18 1/4	5/8	7/8	33 1/4	8 1/2	3 1/2	2 1/2	27 1/2	16	16 x 20 x 1
75,000	54	13 1/2	23 1/8	11 1/8	21 1/8	4	3	18 1/4	5/8	7/8	33 1/4	8 1/2	3 1/2	2 1/2	27 1/2	16	16 x 20 x 1
100,000	54	17	23 1/8	15 1/8	21 1/8	5	5	18 1/4	5/8	7/8	33 1/4	8 1/2	3 1/2	2 1/2	27 1/2	16	20 x 20 x 1
125,000	58	20 1/2	23 1/8	18 1/8	21 1/8	5	5	18 1/4	5/8	7/8	35 1/4	9 1/2	3 1/2	2 1/2	29 1/2	17 1/4	20 x 25 x 1
140,000	58	24	23 1/8	22 1/8	21 1/8	6	6	18 1/4	5/8	7/8	35 1/4	9 1/2	3 1/2	2 1/2	29 1/2	17 1/4	20 x 25 x 1

* HIGH VELOCITY TYPE FILTERS REQUIRED



GENERAL LAYOUT

FIG. 16