

# **ALTUSCN™**

Enterprise KVM Solutions by ATEN

## **Combo Graphic Console Module KA9233 User Manual**



[www.aten.com](http://www.aten.com)

## FCC Information

This is an FCC Class A product. In a domestic environment this product may cause radio interference in which case the user may be required to take adequate measures.

This equipment has been tested and found to comply with the limits for a Class A digital device, pursuant to Part 15 of the FCC Rules. These limits are designed to provide reasonable protection against harmful interference when the equipment is operated in a commercial environment. This equipment generates, uses and can radiate radio frequency energy and, if not installed and used in accordance with the instruction manual, may cause harmful interference to radio communications. Operation of this equipment in a residential area is likely to cause harmful interference in which case the user will be required to correct the interference at his own expense.

## RoHS

This product is RoHS compliant.

## SJ/T 11364-2006

The following contains information that relates to China:

部件名称	有毒有害物质或元素					
	铅	汞	镉	六价铬	多溴联苯	多溴二苯醚
电器部件	●	○	○	○	○	○
机构部件	○	○	○	○	○	○

- : 表示该有毒有害物质在该部件所有均质材料中的含量均在SJ/T 11363-2006规定的限量要求之下。
- : 表示符合欧盟的豁免条款, 但该有毒有害物质至少在该部件的某一均质材料中的含量超出SJ/T 11363-2006的限量要求。
- ×: 表示该有毒有害物质至少在该部件的某一均质材料中的含量超出SJ/T 11363-2006的限量要求。



## User Information

---

### Online Registration

Be sure to register your product at our online support center:

International	<a href="http://eservice.aten.com">http://eservice.aten.com</a>
---------------	---

### Telephone Support

For telephone support, call this number:

International	886-2-8692-6959
China	86-10-5255-0110
Japan	81-3-5615-5811
Korea	82-2-467-6789
North America	1-888-999-ATEN ext 4988
United Kingdom	44-8-4481-58923

### User Notice

All information, documentation, and specifications contained in this manual are subject to change without prior notification by the manufacturer. The manufacturer makes no representations or warranties, either expressed or implied, with respect to the contents hereof and specifically disclaims any warranties as to merchantability or fitness for any particular purpose. Any of the manufacturer's software described in this manual is sold or licensed *as is*. Should the programs prove defective following their purchase, the buyer (and not the manufacturer, its distributor, or its dealer), assumes the entire cost of all necessary servicing, repair and any incidental or consequential damages resulting from any defect in the software.

The manufacturer of this system is not responsible for any radio and/or TV interference caused by unauthorized modifications to this device. It is the responsibility of the user to correct such interference.

The manufacturer is not responsible for any damage incurred in the operation of this system if the correct operational voltage setting was not selected prior to operation. **PLEASE VERIFY THAT THE VOLTAGE SETTING IS CORRECT BEFORE USE.**

## Safety Instructions

---

### General

- ◆ Read all of these instructions. Save them for future reference.
- ◆ Follow all warnings and instructions marked on the device.
- ◆ Do not place the device on any unstable surface (cart, stand, table, etc.). If the device falls, serious damage will result.
- ◆ Do not use the device near water.
- ◆ Do not place the device near, or over, radiators or heat registers.
- ◆ The device cabinet is provided with slots and openings to allow for adequate ventilation. To ensure reliable operation, and to protect against overheating, these openings must never be blocked or covered.
- ◆ The device should never be placed on a soft surface (bed, sofa, rug, etc.) as this will block its ventilation openings. Likewise, the device should not be placed in a built in enclosure unless adequate ventilation has been provided.
- ◆ Never spill liquid of any kind on the device.
- ◆ Unplug the device from the wall outlet before cleaning. Do not use liquid or aerosol cleaners. Use a damp cloth for cleaning.
- ◆ The device should be operated from the type of power source indicated on the marking label. If you are not sure of the type of power available, consult your dealer or local power company.
- ◆ The device is equipped with a 3-wire grounding type plug. This is a safety feature. If you are unable to insert the plug into the outlet, contact your electrician to replace your obsolete outlet. Do not attempt to defeat the purpose of the grounding-type plug. Always follow your local/national wiring codes.
- ◆ Do not allow anything to rest on the power cord or cables. Route the power cord and cables so that they cannot be stepped on or tripped over.
- ◆ If an extension cord is used with this device make sure that the total of the ampere ratings of all products used on this cord does not exceed the extension cord ampere rating. Make sure that the total of all products plugged into the wall outlet does not exceed 15 amperes.
- ◆ To help protect your system from sudden, transient increases and decreases in electrical power, use a surge suppressor, line conditioner, or uninterruptible power supply (UPS).

- ◆ When connecting or disconnecting power to hot pluggable power supplies, observe the following guidelines:
- ◆ Install the power supply before connecting the power cable to the power supply.
- ◆ Unplug the power cable before removing the power supply.
- ◆ If the system has multiple sources of power, disconnect power from the system by unplugging all power cables from the power supplies.
- ◆ Never push objects of any kind into or through cabinet slots. They may touch dangerous voltage points or short out parts resulting in a risk of fire or electrical shock.
- ◆ Do not attempt to service the device yourself. Refer all servicing to qualified service personnel.
- ◆ If the following conditions occur, unplug the device from the wall outlet and bring it to qualified service personnel for repair.
  - ◆ The power cord or plug has become damaged or frayed.
  - ◆ Liquid has been spilled into the device.
  - ◆ The device has been exposed to rain or water.
  - ◆ The device has been dropped, or the cabinet has been damaged.
  - ◆ The device exhibits a distinct change in performance, indicating a need for service.
  - ◆ The device does not operate normally when the operating instructions are followed.
- ◆ Only adjust those controls that are covered in the operating instructions. Improper adjustment of other controls may result in damage that will require extensive work by a qualified technician to repair.

## **Rack Mounting**

- ◆ Before working on the rack, make sure that the stabilizers are secured to the rack, extended to the floor, and that the full weight of the rack rests on the floor. Install front and side stabilizers on a single rack or front stabilizers for joined multiple racks before working on the rack.
- ◆ Always load the rack from the bottom up, and load the heaviest item in the rack first.
- ◆ Make sure that the rack is level and stable before extending a device from the rack.
- ◆ Do not overload the AC supply branch circuit that provides power to the rack. The total rack load should not exceed 80 percent of the branch circuit rating.
- ◆ Ensure that proper airflow is provided to devices in the rack.
- ◆ Do not step on or stand on any device when servicing other devices in a rack.

## Package Contents

---

The KA9233 package consists of:

- 1 Combo Graphic Console Module with Stacking Brackets
- 1 KVM Cable
- 1 Power Adapter
- 1 Rack Mount Kit
- 1 User Manual\*
- 1 Quick Start Guide

Check to make sure that all of the components are present and in good order. If anything is missing, or was damaged in shipping, contact your dealer.

Read this manual thoroughly and follow the installation and operation procedures carefully to prevent any damage to the switch or to any other devices on the KA9233 installation.

---

\* Changes may have been made to the manual since it was published. Please visit our Website to check for the most up-to-date version.

---

Copyright © 2007-2013 ATEN® International Co., Ltd.  
Manual Part No. PAPE-0273-1AXG  
Printing Date: 27 March 2013

Altusen and the Altusen logo are registered trademarks of ATEN International Co., Ltd. All rights reserved.  
All other brand names and trademarks are the registered property of their respective owners.

# Contents

---

FCC Information . . . . .	ii
RoHS . . . . .	ii
SJ/T 11364-2006 . . . . .	ii
User Notice . . . . .	iii
Online Registration . . . . .	iii
Online Support . . . . .	iii
Safety Instructions . . . . .	iv
General . . . . .	iv
Rack Mounting . . . . .	vi
Package Contents . . . . .	vii
About This Manual . . . . .	xi
Overview . . . . .	xi
Conventions . . . . .	xii
Technical Support . . . . .	xiii
International . . . . .	xiii
North America . . . . .	xiii
Product Information . . . . .	xiv

## **Chapter 1.**

### **Introduction**

Overview . . . . .	1
Features . . . . .	2
Requirements . . . . .	3
Consoles . . . . .	3
Computers . . . . .	3
Cables . . . . .	3
Operating Systems . . . . .	3
KA9233 Front View . . . . .	4
KA9233 Rear View . . . . .	5

## **Chapter 2.**

### **Installation**

Before you Begin . . . . .	7
Stacking and Rack Mounting . . . . .	7
Stacking . . . . .	7
Rack Mounting . . . . .	8
Installation . . . . .	10
Verifying the Connection to the Matrix KVM Switch . . . . .	11
Topology Considerations . . . . .	11
Basic Operation . . . . .	11
Hot Plugging . . . . .	11
Hot Plugging User Ports . . . . .	11



**Chapter 3.****Operation**

Overview . . . . .	13
Switching Between the Local Computer and the Matrix KVM Switch . . . . .	13
Adjusting the Picture Quality . . . . .	14
Logging in to the Graphical OSD . . . . .	15
The Graphical OSD . . . . .	16
Menus . . . . .	16
Icons . . . . .	16
Tree View Icons . . . . .	17
Navigating the Graphical OSD . . . . .	17
Shortcut Keys . . . . .	17
Port ID Numbering . . . . .	19
Cascaded Installations . . . . .	19
Matrix Plus KVM Adapter Cable Installations . . . . .	19
Daisy-Chained Installations . . . . .	19
Port Status . . . . .	21
Accessing Devices Attached to the Matrix KVM Switch . . . . .	22
Skipping and Scanning Attached Computers . . . . .	23
Setting the OSD View . . . . .	24
View Mode . . . . .	25
Set Port ID . . . . .	25
Display Duration . . . . .	26
Set Scan . . . . .	26
Configuring OSD User Settings . . . . .	27
Viewing Help . . . . .	29
Logging Out . . . . .	29

**Chapter 4.****Hotkey Mode**

Hotkey Port Control . . . . .	31
Invoking Hotkey Mode . . . . .	31
Port Switching . . . . .	32
Switching to Ports . . . . .	32
Auto Scanning . . . . .	33
Setting the Scan Interval . . . . .	33
Invoking Auto Scan . . . . .	34
Hotkey Beeper Control . . . . .	35
Hotkey Summary Table . . . . .	36

**Chapter 5.****Administration**

Overview . . . . .	37
Naming Stations . . . . .	37
Setting the Webpage Session Timeout . . . . .	38
Network Configuration . . . . .	39

IP Installer Setting . . . . .	39
IP Address . . . . .	40
Port Settings . . . . .	40
System Event Reports . . . . .	41
Setting the Date and Time . . . . .	42
Group Management . . . . .	44
Adding Groups . . . . .	45
Modifying Groups . . . . .	46
Deleting Groups . . . . .	46
Managing Port Access Rights for Groups . . . . .	47
User Management . . . . .	49
Adding Users . . . . .	51
Modifying Users . . . . .	53
Deleting Users . . . . .	53
Managing Port Access Rights for Users . . . . .	53
Port Management . . . . .	56
Accessing Ports . . . . .	57
Managing Port Access . . . . .	58
Cascaded Installations . . . . .	61
Configuring Port Settings . . . . .	62
Restoring Port Defaults . . . . .	63
Searching for Ports and Stations . . . . .	64
Upgrading Firmware . . . . .	65
Preparing to Upgrade the Firmware . . . . .	65
Downloading the Firmware Upgrade Package . . . . .	66
Upgrading the Firmware . . . . .	66
Upgrade Failed . . . . .	70
Viewing and Clearing the Log File . . . . .	71
Broadcasting Commands . . . . .	73
Viewing System Information . . . . .	74

## **Chapter 6.**

### **Keyboard Emulation**

Apple Keyboard . . . . .	75
Sun Keyboard . . . . .	76

### **Appendix**

Specifications . . . . .	77
Factory Default Settings . . . . .	78
Entering the ok Prompt (Sun Solaris) . . . . .	78
Troubleshooting . . . . .	79
General . . . . .	79
Sun Systems . . . . .	80
Limited Warranty . . . . .	81

### **Index**

## About This Manual

---

This User Manual is provided to help you get the most from your KA9233 system. It covers all aspects of installation, configuration, and operation. An overview of the information found in the manual is provided below.

### Overview

**Chapter 1, Introduction**, introduces you to the KA9233 system. Its purpose, features, and benefits are presented, and its front and back panel components are described.

**Chapter 2, Installation**, provides step-by-step instructions for setting up your installation, and explains some basic operating procedures.

**Chapter 3, Operation**, describes how to log into the KA9233 and provides detailed information for configuring and controlling your installation using the KA9233's intuitive, Graphical OSD (On Screen Display).

**Chapter 4, Hotkey Mode**, explains the concepts and procedures used to control the KA9233 from the keyboard.

**Chapter 5, Administration**, explains the administrative procedures that are employed to configure the matrix KVM switch's working environment using the Graphical OSD.

**Chapter 6, Keyboard Emulation**, lists the keys for a PC keyboard to emulate the functions of the Apple and Sun keyboards.

**An Appendix** at the end of the manual provides technical and troubleshooting information.

## **Conventions**

This manual uses the following conventions:

- |   |  |
|---|--|
| Monospaced  | Indicates text that you should key in.   |
| [ ]   | Indicates keys you should press. For example, [Enter] means to press the <b>Enter</b> key. If keys need to be chorded, they appear together in the same bracket with a plus sign between them: [Ctrl+Alt]. |
| 1.  | Numbered lists represent procedures with sequential steps.   |
| ◆   | Bullet lists provide information, but do not involve sequential steps.   |
| →   | Indicates selecting the option (on a menu or dialog box, for example), that comes next. For example, Start → Run means to open the <i>Start</i> menu, and then select <i>Run</i> .                         |
|  | Indicates critical information.  |

## Technical Support

### International

Technical Phone Support	<ol style="list-style-type: none"> <li>1. Contact your local dealer.</li> <li>2. Call the ALTUSEN Technical Support Center: 886-2-8692-6959</li> </ol>
Email Support	Email your questions and concerns to: support@aten.com
Online Support <ul style="list-style-type: none"> <li>◆ Technical Support</li> <li>◆ Troubleshooting</li> <li>◆ Documentation</li> <li>◆ Software Updates</li> </ul>	<ol style="list-style-type: none"> <li>1. Online technical support is available to ALTUSEN customers through our e-Support Center: <b>http://support.aten.com</b></li> <li>2. Online troubleshooting that describes the most commonly encountered problems and offers possible solutions to them; online documentation (including electronically available manuals); and the latest drivers and firmware for your product are available at our Website: <b>http://www.aten.com</b></li> </ol>

### North America

Technical Phone Support	Registered ALTUSEN product owners are entitled to telephone technical support. Call the ALTUSEN Technical Support Center: 1-888-999-ATEN
Email Support	Email your questions and concerns to: support@aten-usa.com
Online Support <ul style="list-style-type: none"> <li>◆ Technical Support</li> <li>◆ Troubleshooting</li> <li>◆ Documentation</li> <li>◆ Software Updates</li> </ul>	<ol style="list-style-type: none"> <li>1. Online technical support is available to ALTUSEN customers through our e-Support Center: <b>http://www.aten-usa.com/support</b></li> <li>2. Online troubleshooting that describes the most commonly encountered problems and offers possible solutions to them; online documentation (including electronically available manuals); and the latest drivers and firmware for your product are available at our Website: <b>http://www.aten-usa.com</b></li> </ol>

When you contact us, please have the following information ready beforehand:

- ◆ Product model number, serial number, and date of purchase
- ◆ Your computer configuration, including operating system, revision level, expansion cards, and software
- ◆ Any error messages displayed at the time the error occurred
- ◆ The sequence of operations that led up to the error
- ◆ Any other information you feel may be of help

## Product Information

---

For information about all ALTUSEN products and how they can help you connect without limits, visit ALTUSEN on the Web or contact an ALTUSEN Authorized Reseller. Visit ALTUSEN on the Web for a list of locations and telephone numbers:

International	<a href="http://www.aten.com">http://www.aten.com</a>
North America	<a href="http://www.aten-usa.com">http://www.aten-usa.com</a>

# Chapter 1

## Introduction

### Overview

---

The Altusen KA9233 Combo Graphic Console Module offers secure access to the servers in a matrix KVM switch from a keyboard, monitor, mouse (KVM) console or a computer workstation. It provides user-friendly server management, flexible console interface support, and superior video graphics.

The KA9233 has console ports for both PS/2 and USB keyboards and mice and an SPHD port for integration with a computer workstation. It enables network administrators to seamlessly switch between a workstation computer and servers in the matrix KVM switch. This eliminates the constant need to move from one workstation to another to manage servers. Moreover, because the KA9233 can be placed up to 300 meters (980') away from the servers, network administrators can respond to problems as they arise, not only when they have time to visit the data center.

An intuitive graphical user interface, the Graphical OSD, features easy-to-use menus, icons, and shortcut keys to access servers, manage users and groups, control port access, upgrade firmware versions, and perform many other administrative functions. Login password protection and three-level user access control ensure that unauthorized users cannot gain control of the servers in your matrix KVM switch. The Graphical OSD is platform independent and does not require you to install any software.

Superior video display resolutions are supported up to 2048 x 1536 for the local computer and 1024 x 768 for the matrix KVM switch for crisp, clear graphics. Support for Display Data Channel (DDC) emulation eliminates complex power on procedures and ensures the highest possible video resolution.

As server densities increase, so does cable bulk. To combat this effect, the KA9233 uses a single, economical Cat 5 cable to connect to the matrix KVM switch, greatly reducing cable volume and the overall cost of the installation.

Other useful features include Auto Scan mode to continuously monitor servers, a log file, free lifetime firmware upgrades, and a 1U rack mount kit.

## Features

---

- ◆ One Combo Graphic Console Module can control a workstation computer and a remote matrix KVM switch installation
- ◆ Supports PS/2 and USB keyboards and mice
- ◆ New Graphical OSD—intuitive, easy-to-use graphical user interface to manage the matrix KVM switch and port switching
- ◆ Supports login password authentication
- ◆ Supports three-level user access control (Super Administrator, Administrator, and User)
- ◆ Configure port access rights via user or group account settings, or on a port-by-port basis
- ◆ Automatically scan attached computers at regular intervals
- ◆ Connects to matrix KVM switch via economical Cat 5 (or higher) cable
- ◆ Superior video quality—2048 x 1536 @ 60Hz for up to 10m for local computer; 1024 x 768 @ 60Hz for up to 300 meters from Combo Graphic Console Module to KVM adapter cable (CPU module)
- ◆ Full-screen Graphical OSD (800 x 600, 16-bit color)
- ◆ Automatic video gain control
- ◆ Manual video gain control to fine tune the video signal
- ◆ Extensive sets of hotkeys and shortcut keys enable you to quickly switch between the workstation computer, Graphical OSD, and ports on the matrix KVM switch, operate the Graphical OSD entirely from the keyboard, invoke Auto Scan mode, and more
- ◆ OSD hotkey is customizable to avoid conflict with programs running on computers
- ◆ Supports Logitech and Microsoft wireless mice
- ◆ LCD, VGA, SVGA, XGA, and MultiSync support; DDC2B (local computer)
- ◆ Built in ASIC for greater reliability and compatibility
- ◆ No software to install
- ◆ Free lifetime flash firmware upgrades
- ◆ Rack mounts in 1U of rack space



## Requirements

---

### Consoles

The following equipment is required for the console:

- ◆ A VGA, SVGA, XGA, or MultiSync monitor capable of displaying the highest resolution provided by any computer in the installation
- ◆ Keyboard and mouse (PS/2 or USB)

### Computers

The following equipment is required for the local computer:

- ◆ A VGA, SVGA, XGA, or MultiSync video graphics card with an HDB-15 port
- ◆ PS/2 mouse and keyboard ports (6-pin mini-DIN), or one USB port

### Cables

One or more of the following cables are required for use with the KA9233:

Type	Description
Cat 5 Cable	Connects the KA9233 to a matrix KVM switch
KVM Cable	Connects a local computer to the KA9233: <ul style="list-style-type: none"> <li>◆ Computers with PS/2 ports use Part No. 2L-5202P</li> <li>◆ Computers with a USB port use Part No. 2L-5202U</li> </ul>

### Operating Systems

- ◆ Microsoft® Windows® 2000 and higher
- ◆ Mac OS® 9.0 and higher
- ◆ RED HAT® Linux® 6.0, 7.1, 7.2, 7.3, 8.0 and higher
- ◆ Mandriva Linux 9.0 and higher
- ◆ SUSE 8.2 and higher
- ◆ Free BSD 3.5.1, 4.2, 4.3, 4.5 and higher
- ◆ Sun Solaris™ 8 and higher
- ◆ Netware 5.0, 6.0 and higher
- ◆ OS/2 Ver 2.0
- ◆ AIX 4.3 and higher
- ◆ DOS 6.22

## KA9233 Front View

---

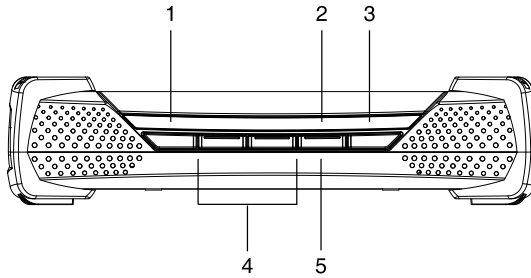

- 1. LINK LED**
- 2. LOCAL LED**
- 3. REMOTE LED**
- 4. Video Gain Buttons**
- 5. LOCAL/REMOTE Button**

## KA9233 Rear View

---

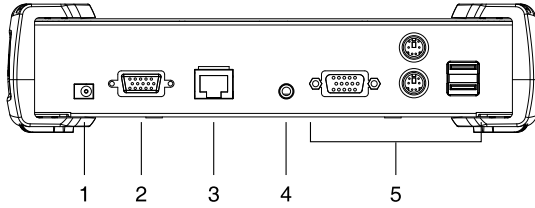

- 1. Power Jack**
- 2. LOCAL PC Port**
- 3. LINK Port**
- 4. FW UPGRADE Port**
- 5. CONSOLE Section**

This Page Intentionally Left Blank

# Chapter 2

## Installation

### Before you Begin

---



1. Important safety information regarding the placement of this device is provided on page iv. Please review it before proceeding.
2. If you will connect a local computer, ensure it is powered off.
3. Make sure that all devices you will be connecting up are properly grounded.

### Stacking and Rack Mounting

---

The KA9233 can be stacked on the desktop or rack mounted in 1U of rack space.

#### **Stacking**

The KA9233 can be placed on any level surface that can safely support its weight and the weight of the attached cables. Ensure that the surface is clean and free of materials that can interfere with the normal operation of the device. The stacking brackets provide an easy method to securely stack multiple KA9233 together.

## **Rack Mounting**

1. Remove the 2 stacking brackets from the sides of the unit. This requires using a Phillips head hex screwdriver to remove the 8 screws that attach the stacking brackets to the unit.

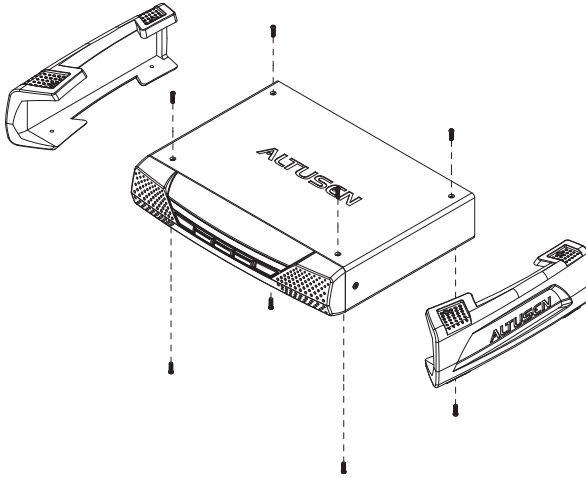

2. Remove the 4 screws from the sides and bottom at the front of the unit. Using the screws provided with the rack mount kit, attach the rack mount brackets to the sides of the unit (as shown in the figure below). There are two sets of screw holes on the rack mount brackets so that the KA9233 can be rack mounted either flush with the rack or with the front panel protruding.

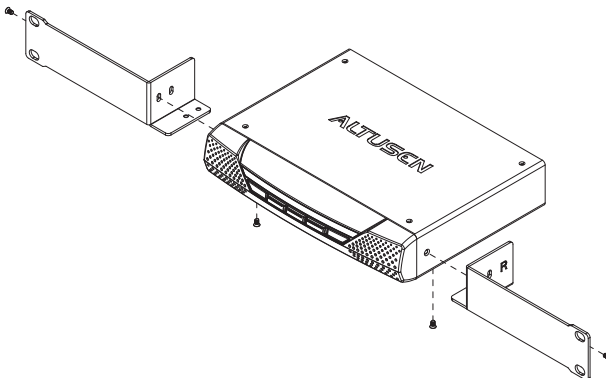

3. Attach the unit to the front of the rack. Position it so that the holes in the mounting brackets line up with those in the rack. Secure the mounting brackets to the rack. Cage nuts are provided for racks that are not prethreaded.

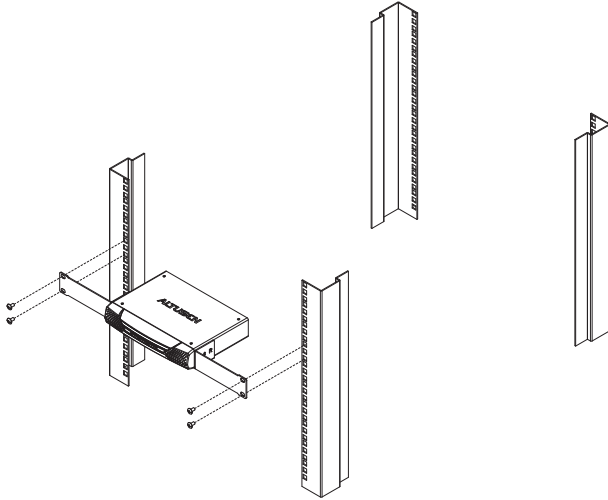

## Installation

Follow these steps to install your new KA9233 Combo Graphic Console Module:

1. Connect your monitor and PS/2 or USB keyboard and mouse to the CONSOLE ports on the KA9233. Each port is marked with an identifying icon.
2. (*Optional*) Use the provided KVM cable to connect a computer to the LOCAL PC port.
3. Use Cat 5 cable to connect the LINK port on the KA9233 to a user port on the rear panel of the matrix KVM switch.
4. Connect the power adapter to an AC mains power source appropriate for your model, and then connect the power adapter cable to the KA9233. You will hear a long beep and the LED indicators on the front panel will illuminate for a moment.
5. If you connected a computer to the LOCAL PC port, you may turn it on now.

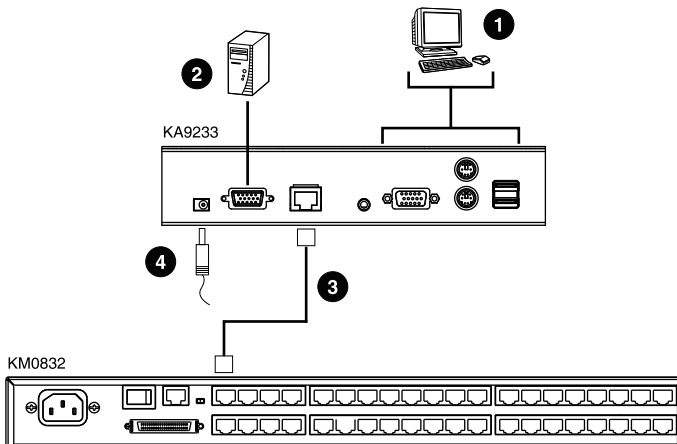



## Verifying the Connection to the Matrix KVM Switch

---

The LINK LED indicator on the front panel of the KA9233 illuminates when the KA9233 establishes a valid connection to a matrix KVM switch that is powered on. It flashes when the KA9233 transmits and receives data.

## Topology Considerations

---

The KA9233 operates with the matrix KVM switch at distances up to 300 meters between the Combo Graphic Console Module and KVM adapter cables, while still maintaining reliability and high video resolution. This allows the matrix KVM switch installation to take advantage of the internal Cat 5e and Cat 6 wiring built-in to most modern commercial buildings.

Since the data signals are not transmitted in packets, the transmission cannot go through network hubs or switches. Passive components such as patch panels, keystone jacks, patch cables, etc. can be used to channel the traffic, instead.

## Basic Operation

---

### Hot Plugging

The KA9233 supports *hot plugging*—components can be removed and added back into the KA9233 by unplugging their cables from the ports without the need to shut the console module down. In order for hot plugging to work properly, however, the procedure described below must be followed:

### Hot Plugging User Ports

The keyboard, monitor, and mouse all can be hot plugged. If you experience a problem after you plug in a new mouse, unplug the power adapter cable from the KA9233 and plug it in again.

This Page Intentionally Left Blank

# Chapter 3

## Operation

### Overview

---

In this chapter we explain how to use the Graphical OSD to access target devices attached to the matrix KVM switch installation. Users also can automatically monitor target devices in Auto Scan mode and manually skip forward and backward through them. We also show users how to make changes to their profiles and set up their personal working environments.

### Switching Between the Local Computer and the Matrix KVM Switch

---

Press the LOCAL/REMOTE button located on the front panel of the KA9233 to switch between the matrix KVM switch and the computer attached to the LOCAL PC port. (The LOCAL LED indicator illuminates when accessing the local computer, and the REMOTE LED indicator illuminates when accessing the matrix KVM switch.) Or, follow this procedure to use a hotkey combination to perform this function:

1. Press and hold down the [Num Lock] key.
2. Press and release the minus (-) key or the asterisk (\*) key two times.
3. Release the [Num Lock] key.

[Num Lock] + [-] + [-]

-or-

[Num Lock] + [\*] + [\*]

4. Repeat this procedure to return to the previous screen.

## **Adjusting the Picture Quality**

---

The length and quality of Cat 5 cable used to connect the KA9233 to the matrix KVM switch can affect picture quality when viewing computers attached to the matrix KVM switch. (The picture quality of the local computer is not affected by the Cat 5 cable.) Use the video gain buttons on the front panel of the KA9233 to adjust the picture quality. If the picture quality appears poor, press **VIDEO GAIN +** to improve it. If the picture appears too bright, press **VIDEO GAIN -** to normalize the picture.

## Logging in to the Graphical OSD

To log in to the Graphical OSD:

1. After powering on the KA9233, the **Login** screen appears.

**Note:** If the Login screen does not appear, press the LOCAL/REMOTE button on the front panel of the KA9233.

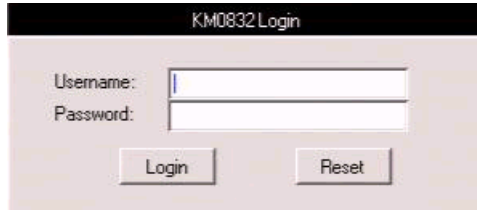

2. Enter your username and password, and then click **Login**. (Usernames and passwords are not case-sensitive.) Upon successfully logging in, the Graphical OSD main screen appears.

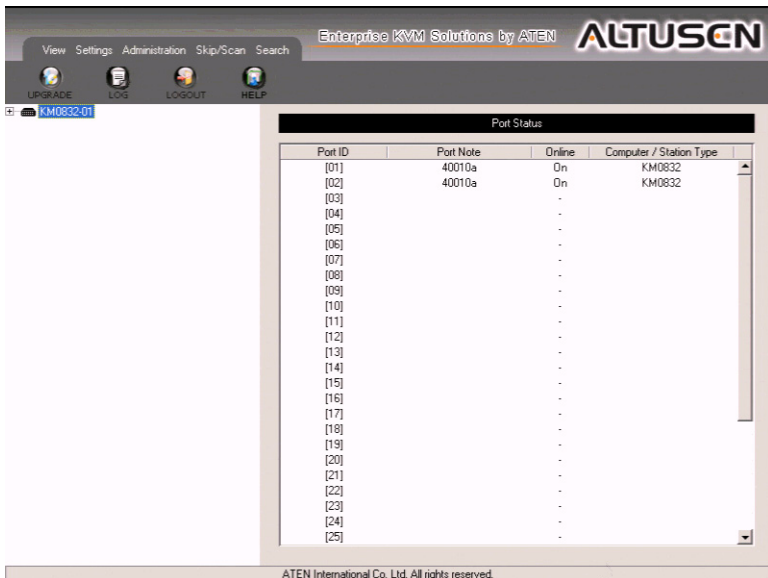

Port ID	Port Note	Online	Computer / Station Type
[01]	40010a	On	KM0832
[02]	40010a	On	KM0832
[03]	-	-	-
[04]	-	-	-
[05]	-	-	-
[06]	-	-	-
[07]	-	-	-
[08]	-	-	-
[09]	-	-	-
[10]	-	-	-
[11]	-	-	-
[12]	-	-	-
[13]	-	-	-
[14]	-	-	-
[15]	-	-	-
[16]	-	-	-
[17]	-	-	-
[18]	-	-	-
[19]	-	-	-
[20]	-	-	-
[21]	-	-	-
[22]	-	-	-
[23]	-	-	-
[24]	-	-	-
[25]	-	-	-

ATEN International Co. Ltd. All rights reserved.

## The Graphical OSD

### Menus

The menus at the top of the Graphical OSD are described in the table below:

Menu	Description
View	Clicking the View menu opens the View screen, which allows the user to set screen viewing options. (See <i>Setting the OSD View</i> , page 24.)
Settings	Clicking the Settings menu opens the Settings screen. Users can change their account passwords; they also can set the OSD activation keys, time to logout, and screen blanker, as well as turn on and off both the hotkey commands and the beeper, and set the idle timeout. (See <i>Configuring OSD User Settings</i> , page 27.)
Administration	Clicking the Administration menu opens a pop-up menu. From this menu, administrators and super administrators can manage users, ports, and stations. In addition, super administrators can manage groups, configure the network settings, set the date and time, broadcast, and view the system information for the matrix KVM switch. (Administration is discussed in Chapter 5.)
Skip/Scan	Clicking the Skip/Scan menu starts Auto Scan mode. (See <i>Skipping and Scanning Attached Computers</i> , page 23.)
Search	Clicking the Search menu opens the Search screen. The user can search for computers and stations on the matrix KVM switch installation. (See <i>Searching for Ports and Stations</i> , page 64.)

### Icons

The icons at the top of the Graphical OSD are described in the table below:

Icon	Description
UPGRADE	The Super Administrator can click this icon to upgrade the firmware version of the KA9233. (See <i>Upgrading Firmware</i> , page 65.)
LOG	Clicking the Log icon opens the Event Log screen, which allows administrators to view all of the events that took place on the matrix KVM switch system. (See <i>Viewing and Clearing the Log File</i> , page 71.)
LOGOUT	Clicking the Logout icon closes the user's session.
HELP	Clicking the Help icon opens the KA9233 help file.

## **Tree View Icons**

A tree at the left side of the main screen displays the stations and ports. The matrix KVM switch *root station* icon (at the top of the tree) represents the root node. Under the root station icon are *computer* icons and station icons, which represent the child nodes—one for each KVM port and arranged in ascending order. (If you cannot see all 32 computer icons, refer to *View Mode*, page 25, to change the view settings.) Clicking on a station icon opens the Port Status screen for the cascaded station connected to the KVM port. Clicking the plus sign (+) next to a station icon expands the KVM ports on that station. Clicking on a computer icon opens the Port Management screen for that KVM port. The port ID is displayed in brackets. (See *Port ID Numbering*, page 19, for an explanation of the port ID.)

## **Navigating the Graphical OSD**

You can navigate the Graphical OSD and perform operations using the intuitive menus and icons. Or, you can perform all the same functions using shortcut keys.

### **Shortcut Keys**

The KA9233 has numerous shortcut keys that allow you to move through the Graphical OSD screens and perform operations.

<b>Press</b>	<b>To</b>
F1	Open Help.
F2	Open the View screen.
F3	Open the Settings screen.
F4	Open the System Information screen.
F5	Open the Search screen.
F6	Open the Log screen.
F7	Start Auto Scan mode.
F8	Log out of the KA9233.
F9	Select the tree view.
F10	Start Firmware Upgrade mode.
Ctrl+U	Open the User Management screen.

*(continues on next page)*

*(continued from previous page)*

<b>Press</b>	<b>To</b>
Ctrl+G	Open the Group Management screen.
Ctrl+P	Open the Port Select screen for the root station, or whatever station is currently selected.
Ctrl+S	Open the Station Management screen for the root station, or whatever station is currently selected.
Ctrl+N	Open the Network Settings screen.
Ctrl+D	Open the Date & Time screen.
Ctrl+B	Open the Broadcast screen.
Ctrl	Select multiple non-adjacent entries in the Port Management screen by clicking the entries while pressing and holding down Ctrl.
Shift	(Port Management screen) Select multiple adjacent entries by clicking the top and bottom entries of the range while pressing and holding down Shift.  (User and Group Information screens) Set the access rights for a group or user for all ports on a KVM switch by clicking the type of access right you want to assign while pressing and holding down Shift.
Tab	Move forward through the options.
Shift+Tab	Move backward through the options.
Spacebar	Select the radio button if the active option is a radio button. Select or clear the check box if the active option is a check box.
Arrow keys	Move forward and backward through the tree view, port lists, user and group lists, and Date box. Select options in drop-down combo boxes.
U	(User and Group Information screens) Set the access right as Not Assigned for the highlighted station/port in the Computer/Station box.
N	(User Information screen) Set the access right as No Access for the highlighted station/port in the Computer/Station box.
V	(User and Group Information screens) Set the access right as View Only for the highlighted station/port in the Computer/Station box.
F	(User and Group Information screens) Set the access right as Full Access for the highlighted station/port in the Computer/Station box.



---

## Port ID Numbering

---

Each port in the KVM installation has a unique port ID. The port ID is composed of up to 4 port numbers separated by hyphens. These port numbers describe a path from the first-level KVM switch through the KVM installation to the target device.

The port numbers that compose the port ID are displayed in the following order from left to right:

### Cascaded Installations

1. The *port number* on the first-level matrix KVM switch
2. The *port number* on the second-level KVM switch (if applicable)
3. The *port number* on the third-level KVM switch (if applicable)
4. The *port number* on the fourth-level KVM switch (if applicable)

For example, a computer attached to **Port 3** of a fourth-level KVM switch, which is cascaded from **Port 6** of a third-level KVM switch, which is cascaded from **Port 15** of a second-level KVM switch, which in turn is cascaded from **Port 8** of the first-level matrix KVM switch, would have a port ID of: **8-15-6-3**.

### Matrix Plus KVM Adapter Cable Installations

1. The *port number* on the first-level matrix KVM switch
2. The *port number* on the second-level KVM switch (if applicable)
3. The *port number* on the third-level KVM switch (if applicable)
4. The *station ID* displayed on the Matrix Plus KVM adapter cable

For example, a computer attached to a Matrix Plus KVM adapter cable with **Station ID 3**, which is cascaded from **Port 6** of a third-level matrix KVM switch, which is cascaded from **Port 15** of a second-level matrix KVM switch, which in turn is cascaded from **Port 8** of the first-level matrix KVM switch, would have a port ID of: **8-15-6-3**.

### Daisy-Chained Installations

1. The port ID for daisy-chained KVM switches begins with “1”.
2. The position of the KM0432 Matrix KVM Switch in the daisy chain. You can determine the position of the KM0432 in the daisy chain by subtracting 1 from its station ID.

For example, the station ID of the first KM0432 in the daisy chain is 2.

$$2 - 1 = 1$$

The KM0432's position in the daisy chain is 1.

The table below lists the KM0432's station ID and its position in the daisy chain.

Station ID	Position in the Daisy Chain
2	1
3	2
4	3
5	4
6	5
7	6
8	7

### 3. The *port number* on the KM0432

For example, a computer attached to **Port 18** of a KM0432, which is in **Position 7** in the daisy chain (Station ID 8), which in turn is daisy-chained from the first-level matrix KVM switch, would have a port ID of: **1-7-18**.

## Port Status

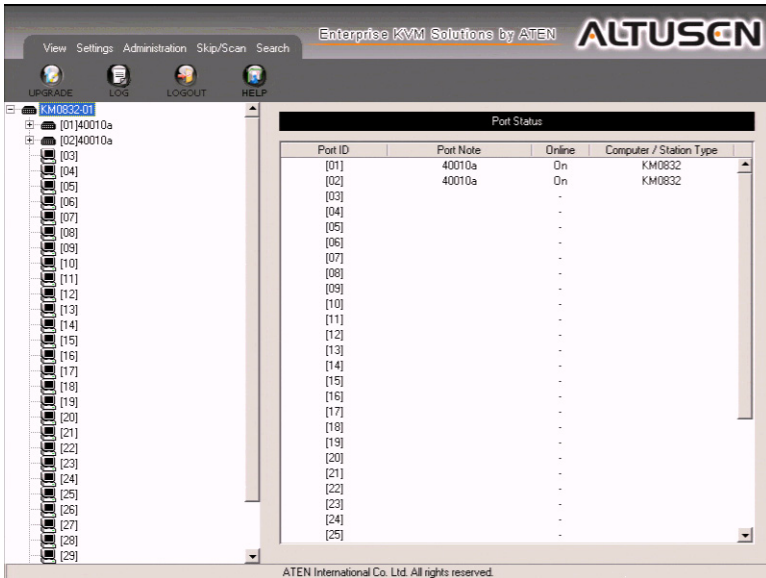

When you log in to the Graphical OSD, the Port Status screen displays by default. (You can display the Port Status screen at any time by clicking on the root station icon in the tree view. You can view the Port Status screen for cascaded stations by clicking the station icon for the cascaded KVM switch.) Users see only those KVM ports for which they have *full access* and *view only* privileges. Clicking on a column heading sorts information in the column by ascending or descending order.

Column	Description
Port ID	Lists the port number. (See <i>Port ID Numbering</i> , page 19.)
Port Note	Displays the Port Note that was assigned to the port (if any). For information about Port Notes see <i>Configuring Port Settings</i> , page 62.
Online	Indicates whether the device attached to the port is powered on.
Computer / Station Type	Displays information about the cascaded matrix KVM switch or KVM adapter cable (CPU module) connected to the port.

## Accessing Devices Attached to the Matrix KVM Switch

---

You can access target devices for which you have been granted port access rights. Use one of the following methods to access a target device attached to the matrix KVM switch:

- ◆ From the Port Status screen, double-click on a port entry. (See *Port Status*, page 21.)
- ◆ Click on a computer icon in the tree. After the Port Management screen appears, double-click the computer icon again to access the attached target device.
- ◆ Invoke Hotkey mode, enter the port ID of the target device, and then press [Enter]. (Chapter 4 discusses Hotkey mode in detail.)

Press the OSD hotkey twice (see *OSD Activation*, page 28) to return to the Graphical OSD.

To set which ports appear on the Port Status screen and in the tree, see *View Mode*, page 25.

## Skipping and Scanning Attached Computers

You can automatically scan target devices by clicking the Skip/Scan icon. In Auto Scan mode, video from each target device is displayed for a length of time set with the Scan Timer. After the interval elapses, Auto Scan mode switches to the next port.

To change which ports are displayed in Auto Scan mode and the scan interval, see *Set Scan*, page 26. (The ports that are available in Auto Scan mode may also depend upon the user's port access rights.)

The following controls are available in Auto Scan mode:

This Keystroke	Does This
[←]	Skips to the previous port in the OSD list.
[→]	Skips to the next port in the OSD list.
[↑]	Skips to the first port in the OSD list.
[↓]	Skips to the last port in the OSD list.
P	Pauses Auto Scan mode.
Single-click	Press any key or single-click again to resume Auto Scan mode.
Spacebar	Exits Auto Scan mode.
Escape	
Right-click	

All other keyboard and mouse input is disabled in Auto Scan mode. To restore normal KVM console operation, you must exit Auto Scan mode.

To scan target devices, do one of the following:

- ◆ Click **Scan/Skip**. Auto Scan mode begins and video displays from the first available target device. After the predetermined amount of time, the next available target device displays.
- ◆ Invoke Hotkey mode, and then type [A]. (Chapter 4 discusses Hotkey mode in detail.)

## Setting the OSD View

Users can log in to the Graphical OSD to set the On Screen Display (OSD) view settings for their accounts. This includes selecting the ports that will appear on the Port Status screen; the type, position and duration of the Port ID display; and the scan mode and scan duration.

To open the View screen:

Click the **View** menu. The **View** screen appears. (The View settings are explained in the tables on the following pages.)

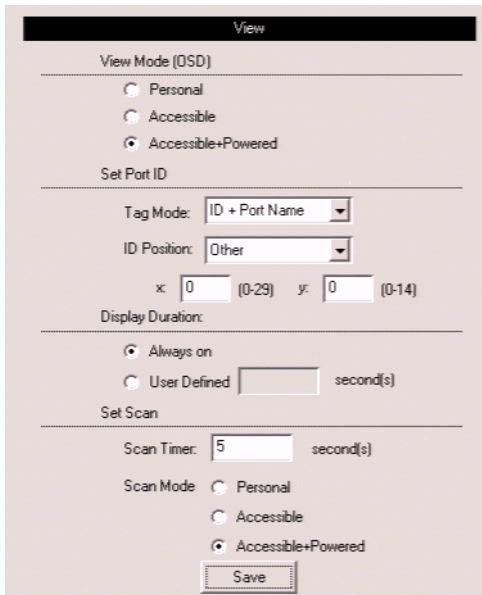

The screenshot shows the 'View' configuration screen for the OSD. It is divided into several sections:

- View Mode (OSD):** Three radio buttons are present: 'Personal' (unselected), 'Accessible' (unselected), and 'Accessible+Powered' (selected).
- Set Port ID:** This section contains:
  - 'Tag Mode:' with a dropdown menu set to 'ID + Port Name'.
  - 'ID Position:' with a dropdown menu set to 'Other'.
  - 'x:' with a text input '0' and a range '(0-29)'. 'y:' with a text input '0' and a range '(0-14)'.
- Display Duration:** Two radio buttons: 'Always on' (selected) and 'User Defined' (unselected). The 'User Defined' option has an empty text input field followed by 'second(s)'.
- Set Scan:** This section contains:
  - 'Scan Timer:' with a text input '5' followed by 'second(s)'.
  - 'Scan Mode:' with three radio buttons: 'Personal' (unselected), 'Accessible' (unselected), and 'Accessible+Powered' (selected).
  - A 'Save' button at the bottom.

## View Mode

Use this function to broaden or narrow the scope of ports that are listed on the Port Status screen and in the tree. The submenu choices and their meanings are given in the table below:

Choice	Meaning
Personal	Some console modules have the option to set the OSD list to display only those ports that the user has set as <i>Personal</i> . The KA9233 does not support this feature. If you set the view as <i>Personal</i> , the KA9233 will instead display all accessible ports. However, when using a console module that supports this feature, only ports that have been set as <i>Personal</i> will be displayed. (See <i>SET PERSONAL VIEW</i> in the matrix KVM switch user manual.)
Accessible	The OSD lists only those ports that the user is permitted to access. See <i>Managing Port Access</i> , page 58.
Accessible + Powered	The OSD lists only those ports that the user is permitted to access and that have their attached computers powered on.

## Set Port ID

When a user switches ports from the OSD, a port ID is shown. The table below explains the choices:

Choice	Meaning
Tag Mode	Selects how the Port ID is displayed: the Port Number alone ( <b>ID</b> ); the Port Note alone ( <b>Port Name</b> ); or the Port Number plus the Port Note ( <b>ID + Port Name</b> ). The default is <b>ID + Port Name</b> .
ID Position	Defines where the Port ID appears on the monitor. The options are <b>Upper left</b> , <b>Upper right</b> , <b>Lower left</b> , <b>Lower right</b> , and <b>Other</b> . If you select <b>Other</b> , enter horizontal and vertical coordinates in the <b>X</b> and <b>Y</b> fields. The default is <b>Upper left</b> .

## Display Duration

Display Duration determines the length of time that the Port ID displays on the screen after a port change. The table below explains the choices:

Choice	Meaning
Always On	Displays the Port ID at all times.
User Defined	Enter a display duration of 1–240 seconds. Enter 0 (zero) to disable the Port ID display function. The default is 3 seconds.

## Set Scan

Select the ports that are viewed under Auto Scan mode and the duration of time that they receive the KVM focus.

Setting	Function
Scan Timer	Determines how long the KVM focus dwells on each port as it cycles through the selected ports in Auto Scan mode (see <i>F7 SCAN</i> in the matrix KVM switch user manual). Enter a value from 0–240 seconds. The default is 5 seconds. Entering 0 will cause the KA9233 to automatically enter Skip mode when Auto Scan mode is invoked.
Scan Mode	Selects which computers will be accessed under Auto Scan mode (see <i>Skipping and Scanning Attached Computers</i> , page 23). Choices are: <b>Personal</b> —Some console modules have the option to scan only those ports that the user has set as <i>Personal</i> . The KA9233 does not support this feature. If you set the Scan Mode as <i>Personal</i> , the KA9233 will instead scan all accessible ports. However, when using a console module that supports this feature, only ports that have been set as <i>Personal</i> will be scanned. (See <i>SET PERSONAL VIEW</i> in the matrix KVM switch user manual.) <b>Accessible</b> —Only those ports that the user is permitted to access. See <i>Managing Port Access</i> , page 58. <b>Accessible + Powered</b> —Only those ports that the user is permitted to access and that have their attached computers powered on. The default is Accessible + Powered.

1. Choose the settings you wish, and then click **Save**.
2. To exit without saving changes, click any other menu or icon.



## Configuring OSD User Settings

Users can change account passwords and set up unique working environments. A separate profile for each user is stored by the matrix KVM switch and is activated according to the username that is provided during login.

To open the Settings screen:

Click the **Settings** menu. The **Settings** screen appears. (The OSD settings are explained in the table on the following page.)

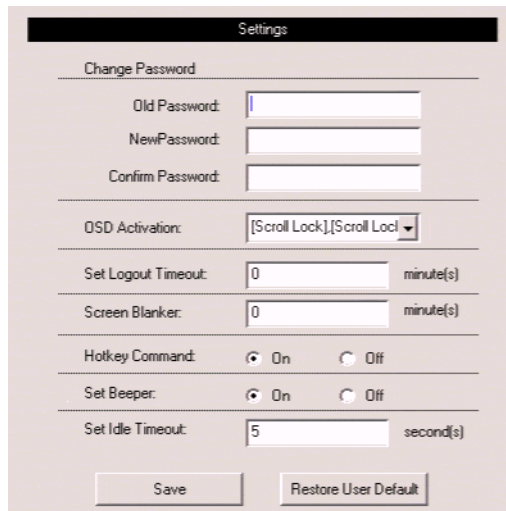

The screenshot shows a 'Settings' window with a black title bar. Below the title bar, there are several sections of settings:

- Change Password:** Three input fields for 'Old Password', 'New Password', and 'Confirm Password'.
- OSD Activation:** A dropdown menu currently showing '[Scroll Lock],[Scroll Lock]'.
- Set Logout Timeout:** An input field with '0' and the unit 'minute(s)'.
- Screen Blanker:** An input field with '0' and the unit 'minute(s)'.
- Holkey Command:** Two radio buttons, 'On' (selected) and 'Off'.
- Set Beeper:** Two radio buttons, 'On' (selected) and 'Off'.
- Set Idle Timeout:** An input field with '5' and the unit 'second(s)'.

At the bottom of the window, there are two buttons: 'Save' and 'Restore User Default'.

(continued from previous page)

Setting	Function
Change Password	Enter the old account password. Enter a new password, and then reenter the password to confirm it. Or, do not enter anything to leave the password unchanged.
OSD Activation	Selects which hotkey combination is used to return to the Graphical OSD from within the matrix KVM switch ports: [Scroll Lock] [Scroll Lock] or [Ctrl] [Ctrl]. Since the Ctrl key combination may conflict with programs running on the computers, the default is the Scroll Lock combination.
Set Logout Timeout	This function allows you to specify the number of minutes to elapse before an inactive user is timed out of the OSD. If there is no input from the user for the specified amount of time, the user will be logged out automatically. The valid range is from 1–180 minutes. Enter 0 (zero) to disable the Logout Timeout function. This function is disabled by default.
Screen Blanker	If there is no input from the console for the amount of time set with this function, the screen is blanked. Key in a value from 1–30 minutes, and then press [Enter]. Enter 0 (zero) to disable the Screen Blanker. This function is disabled by default.
Hotkey Command	Enables or disables Hotkey mode in case a conflict with programs running on the computers occurs. Hotkey mode is On by default. (See <i>Hotkey Mode</i> , page 31.)
Set Beeper	When set to On, the KA9233 beeps when switching ports, when activating Auto Scan mode (see page 23), when switching ports in Auto Scan mode, when exiting Auto Scan mode, or when an invalid entry is made on an OSD menu. The beeper is On by default.
Set Idle Timeout	If there is no input from the console accessing a particular port for the amount of time set with this function, the port is released, allowing it to be accessed by the other consoles. The valid range is from 1–240 seconds. Enter 0 (zero) to disable the Idle Timeout function. The default is 5 seconds.
Restore User Default	Restores the original factory default settings for <b>View Mode (OSD)</b> , <b>Set Port ID</b> , <b>Display Duration</b> , <b>Set Scan</b> , <b>OSD Activation</b> , <b>Set Logout Timeout</b> , <b>Screen Blanker</b> , <b>Hotkey Command</b> , <b>Set Beeper</b> , and <b>Set Idle Timeout</b> .

1. Choose the settings you wish, and then click **Save**.
2. To exit without saving changes, click any other menu or icon.

## Viewing Help

---

Most Graphical OSD functions are described in Help.

To open the help file:

Click the **Help** icon. The **Altusen KA9233 Help** screen appears.

## Logging Out

---

Click the **Logout** icon to end sessions in the Graphical OSD.

This Page Intentionally Left Blank

# Chapter 4

## Hotkey Mode

### Hotkey Port Control

---

Hotkey port control allows you to provide KVM focus to a particular port directly from the keyboard.

---

**Note:** Hotkeys work best in single level and basic cascaded or daisy-chained installations. For installations that combine daisy chaining and cascading, it is simpler, more convenient, and more efficient to use the OSD.

---

The KA9233 provides the following hotkey port control features:

- ◆ Port switching
- ◆ Auto scanning
- ◆ Skip mode switching

### Invoking Hotkey Mode

All hotkey operations begin by invoking Hotkey mode. You must be viewing a port in the matrix KVM switch to invoke Hotkey mode.

To invoke Hotkey mode:

1. Press and hold down the [Num Lock] key.
2. Press and release the minus (-) key or the asterisk (\*) key.
3. Release the [Num Lock] key.

[Num Lock] + [-]

-or-

[Num Lock] + [\*]

When Hotkey mode is active:

- ◆ The Caps Lock and Scroll Lock LED indicators flash in succession. They stop flashing and revert to normal status when you exit Hotkey mode.
- ◆ An on-screen command line appears. The command line prompt is the word *HOTKEY*: in white text on a blue background. Text that you key in while in Hotkey mode displays here.
- ◆ Ordinary keyboard and mouse functions are suspended—only hotkey compliant keystrokes and mouse clicks (described in the sections that follow) can be input.
- ◆ Pressing [Esc] or [Spacebar] exits Hotkey mode.

## **Port Switching**

Each port is assigned a port ID based on its position in the KVM installation (see *Port ID Numbering*, page 19). After invoking Hotkey mode, you can type a port ID to switch directly to any port in the installation. Depending on the position of the port in the installation, the port ID is composed of up to 4 port numbers separated by hyphens.

### **Switching to Ports**

To switch to a port:

1. Invoke Hotkey mode (see page 31).
2. At the command prompt, type the port ID. (see *Port ID Numbering*, page 19, for a description of the port ID.)  
The port ID numbers display on the command line as you type them. If you make a mistake, use [Backspace] to erase the wrong number.
3. Press [Enter].  
After you press [Enter], the KVM focus switches to the designated port, the port ID is displayed, and you automatically exit Hotkey mode.

## **Auto Scanning**

Auto Scan mode switches among all the ports that are accessible to the current operator at regular intervals (see *Scan Mode*, page 26, for information regarding accessible ports). This function is convenient for automatically monitoring the activity of the computers on the installation.

### **Setting the Scan Interval**

The amount of time Auto Scan mode focuses on each port is set with the Scan Timer (see *Set Scan* on page 26). You can change the scan interval before activating Auto Scan mode, if you wish, with the following hotkey combination:

1. Invoke Hotkey mode (see page 31).
2. Key in [T] [n]

Where [T] is the letter **T**, and [n] is a number from 0–240 that represents the number of seconds for the dwell time.

The letter **T** and the numbers display on the command line as you key them in. If you make a mistake, use [Backspace] to erase the wrong number.

3. Press [Enter]

After you press [Enter], you automatically exit Hotkey mode, and are ready to invoke Auto Scanning.

## Invoking Auto Scan

To start Auto Scanning, key in the following hotkey combination:

1. Invoke Hotkey mode (see page 31).
2. Press [A].

After you press **A**, you automatically exit Hotkey mode, and enter Auto Scan mode, and Auto Scanning begins.

- ◆ While you are in Auto Scan mode, you can pause the scanning in order to keep the focus on a particular port either by pressing **P** or with a left-click of the mouse. During the time that Auto Scanning is paused, the command line displays: *AUTOSCAN PAUSED*

Pausing and exiting are the two ways to stop scanning and keep the focus on a particular port. If you intend to continue scanning after a brief stop, pausing is more convenient than exiting Auto Scan mode completely.

This is because when you resume scanning after pausing, you start from where you left off. On the other hand, if you exit and then restart Auto Scan mode, you start over from the very first port on the installation.

To resume Auto Scanning after you pause, press any key or left-click. Scanning continues from where it left off.

- ◆ While you are in Auto Scan mode, you can press the arrow keys to skip through the OSD list:

←	Switches to the previous port in the OSD list.
→	Switches to the next port in the OSD list.
↑	Switches to the first port in the OSD list.
↓	Switches to the last port in the OSD list.

After the amount of time set with the Scan Timer elapses, Auto Scan mode will switch to the next port.

- ◆ While Auto Scan mode is in effect, ordinary keyboard and mouse functions are suspended—only Auto Scan mode compliant keystrokes and mouse clicks can be input. You must exit Auto Scan mode in order to regain normal control of the KVM console.



3. To exit Auto Scan mode press [Esc] or [Spacebar]. Auto Scanning stops when you exit Auto Scan mode.

## **Hotkey Beeper Control**

---

The beeper (see *Set Beeper*, page 28) can be toggled on and off by means of a hotkey. To toggle the beeper, enter the following hotkey combination:

1. Invoke Hotkey mode (see page 31).
2. Press [B]

After you press **B**, the beeper toggles on or off. The command line displays *BEEPER ON* or *BEEPER OFF* for one second; then the message disappears and you automatically exit Hotkey mode.

## Hotkey Summary Table

[Num Lock] + [-] -or- [Num Lock] + [*]	[port ID] [Enter]	Switches to the port that corresponds to that port ID.
	[T] [n] [Enter]	Sets the Auto Scan mode interval to <b>n</b> seconds—where <b>n</b> is a number from 1–240.
	[A]	<p>Invokes Auto Scan mode.</p> <p>When Auto Scan mode is in effect, press [P] or left-click to pause Auto Scan mode. When Auto Scan mode is paused, press any key or left-click to resume Auto Scan mode.</p> <p>Press [Esc] or [Spacebar] to exit Auto Scan mode.</p>
	[←]	In Auto Scan mode, skips to the previous port in the OSD list.*
	[→]	In Auto Scan mode, skips to the next port in the OSD list.*
	[↑]	In Auto Scan mode, skips to the first port in the OSD list.*
	[↓]	In Auto Scan mode, skips to the last port in the OSD list.*
	[B]	Toggles the beeper on or off.

\* The user's Scan Mode settings and port access rights determine which ports are available in Auto Scan mode. To change Scan Mode settings, see *Set Scan*, page 26.

# Chapter 5

## Administration

### Overview

---

Administrators can quickly and efficiently access servers, manage users and groups, control port access, upgrade firmware versions, and perform many other administrative functions. Login password protection and three-tier user access ensure that unauthorized users cannot gain control of the servers in your matrix KVM switch.

### Naming Stations

---

To help distinguish one KVM switch from another in cascaded installations, Super Administrators and Administrators can assign unique names to each KVM switch.

To assign a station name to the KVM switch:

1. Click on the target station in the tree view to select it.
2. From the **Administration** menu, choose **Station Management**. The **Station Management** screen appears.

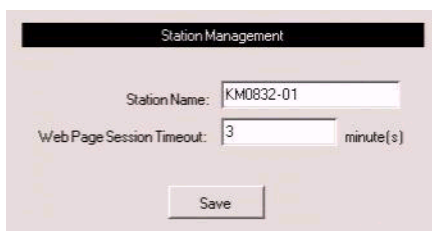

The screenshot shows a web form titled "Station Management". It contains two input fields: "Station Name:" with the text "KM0832-01" and "Web Page Session Timeout:" with the number "3" and the unit "minute(s)". A "Save" button is positioned below these fields.

3. Type a name in the **Station Name** field. Station names may be up to 15 characters long. Legal characters include: a–z, A–Z, 0–9, space, and hyphen. Enter a unique name that will distinguish the KVM switch from all other KVM switches in the installation.
4. Click **Save**.
5. To exit without saving changes, click any other menu or icon.

## Setting the Webpage Session Timeout

---

If the length of time that a user is idle in the KM0832 Administrator Utility exceeds the Webpage Session Timeout setting, the user's session is ended. The valid range for the Webpage Session Timeout is 1–240 minutes. The default is 3 minutes.

To set the Web Page Session Timeout for the KM0832 Administrator Utility:

1. From the **Administration** menu, choose **Station Management**. The **Station Management** screen appears.
2. In the **Web Page Session Timeout** field, specify the number of minutes to elapse before an inactive user is timed out of the *KM0832 Administrator Utility*.
3. Click **Save**.
4. To exit without saving changes, click any other menu or icon.

## Network Configuration

Network configuration is a Super Administrator function. Network settings are configured through the Network Settings screen.

To open the Network Settings screen:

1. From the **Administration** menu, choose **Super Adm Configuration > Set Network**. The **Network Settings** screen appears. (The Network Settings page is described on the following pages.)

2. Choose the settings you wish, and then click **Save**.
3. To exit without saving changes, click any other menu or icon.

### IP Installer Setting

You can use the IP Installer to view and change network settings for the matrix KVM switch. Download the IP Installer from the *KM0832 Driver Download* section of our Website.

- ◆ Click **Enabled** to allow the IP Installer to be used to change the IP address, subnet mask, and gateway for the matrix KVM switch.

- ◆ Click **View Only** to allow the IP Installer to be used to view the IP address, subnet mask, and gateway for the matrix KVM switch.
- ◆ Click **Disabled** to restrict the IP Installer from being used to view or change the network settings for the matrix KVM switch.

## **IP Address**

You can manually enter a static IP address or use a DHCP server to dynamically assign an IP address.

To use a DHCP server to assign an IP address:

1. Under **DHCP Enabled**, click **Yes** to use a DHCP server.

To manually assign an IP address:

1. Under **DHCP Enabled**, click **No**.
2. In the fields under **Manual IP Address**, enter the IP address, subnet mask, default gateway, and primary DNS server. You also can enter an alternate DNS server; however, it is not required.

---

**Note:** If you use a DHCP server to assign an IP address to the matrix KVM switch, you should also enable Mail Notification so that you will be notified whenever the IP address changes.

---

## **Port Settings**

Enter the network ports that the matrix KVM switch will use to transfer Webpages and communicate with clients that access the KM0832 Administrator Utility. Typically, Port 80 is used for Hyper Text Transfer Protocol (HTTP) communications, while Port 443 is used for HTTPS (HTTP over Secure Socket Layer).

---

**Note:** You must assign a port number for each field. Otherwise, the KM0832 Administrator Utility will not function correctly.

---

## **System Event Reports**

The matrix KVM switch can be configured to send an e-mail notification whenever the DHCP server assigns a new IP address to the matrix KVM switch. Enable the Mail Notification feature and specify the Simple Mail Transfer Protocol (SMTP) server address, information for a valid e-mail account on the server, and the e-mail address of the person to whom the message should be sent. When you finish filling in the information, click **Save**.

<b>Field</b>	<b>Description</b>
Mail Notification	Click <b>Yes</b> to enable Mail Notification; click <b>No</b> to disable it.
SMTP Server Address	If you enabled Mail Notification, enter the address of the SMTP server.
SMTP Authentication	If the SMTP server requires authentication, click <b>Yes</b> .
Account Name	Enter the username for a valid e-mail account on the SMTP server.
Password	Enter the password for the e-mail account.
From	Enter the e-mail address for the e-mail account.
To	Enter the e-mail address of the person to whom the notification message should be sent.

## Setting the Date and Time

Super administrators can set the date and time of the matrix KVM switch, which enables the System Log, Active Sessions, and System Information Webpages to maintain accurate time-sensitive data.

To set the date:

1. From the **Administration** menu, choose **Super Adm Configuration > Date & Time**. The **Date & Time** screen appears.

The screenshot shows the 'Date & Time' configuration interface. It includes a calendar for February 2007 with the 2nd selected. Below the calendar, there is a 'Time' field with the value '12:11:04', a 'Time Zone' dropdown menu set to '(GMT+08:00) Taipei', and an unchecked checkbox for 'Daylight Saving Time'. A 'Save' button is positioned at the bottom of the form.

2. Under **Date**, click << or >> to move backward or forward by one year increments to set the year.
3. Under **Date**, click < or > to move backward or forward by one month increments to set the month.
4. Under **Date**, click on the day of the month in the calendar.
5. Click **Save**. Your settings are saved and the date is updated.



To set the time:

1. Under **Time**, use 24-hour notation to type the time as *hours:minutes:seconds*. For example, three o'clock in the afternoon would be written *15:00:00*.
2. Under **Time Zone**, select the time zone in which the matrix KVM switch is located.
3. Select **Daylight Saving Time** (Summer Time) if it is used in the region in which the matrix KVM switch is located.
4. Click **Save**. Your settings are saved and the time is updated.

## Group Management

---

Super administrators can create up to 256 groups on the matrix KVM switch, as well as modify and delete those groups. Super administrators also can grant port access rights to groups. Grouping users together simplifies port management by enabling actions to be performed that affect a whole group of users, rather than only one. (You can still use the User Management screen to change individual user account settings. See *User Management*, page 49.)

All group management operations start from the Group Management screen. It shows all groups that have been created on the matrix KVM switch and provides options for creating new groups and modifying or deleting existing groups.

To access the Group Management screen:

From the **Administration** menu, choose **Account Management > Group Management**. The **Group Management** screen appears.



## **Adding Groups**

To add a new group:

1. In the **Group Management** screen, click **Add**. The **Group Information** screen appears.

Computer/Station	Not Assigned	View Only	Full Access
KM0832-01			

2. Type a name in the **Group Name** field. Group names may be up to 15 characters long. Legal characters include: A–Z, 0–9, space, hyphen, square brackets, parentheses, and period.
3. If you want to assign port access rights for the group, see *Managing Port Access Rights for Groups*, page 47.
4. Click **Save** to add the new group to the matrix KVM switch.
5. To exit without saving changes, click any other menu or icon.

## **Modifying Groups**

To edit a group name:

1. In the **Group Management** screen, select a group name from the list, and then click **Modify**. The **Group Information** screen appears.
2. Edit the group information, and then click **Save**.
3. To exit without saving changes, click any other menu or icon.

## **Deleting Groups**

When you delete a group all users that are members of the group are also deleted. If you do not want to delete certain users in the group, first change the group membership of those users, and then delete the group.

To delete a group:

1. In the **Group Management** screen, select a group name from the list, and then click **Delete**. The group is removed from the list. All users who are members of the group also are deleted from the matrix KVM switch.
2. To exit without saving changes, click any other menu or icon.

## Managing Port Access Rights for Groups

Super administrators can manage port access rights for groups from the Group Information screen.

Please note that you do not need to assign access rights for a group to KVM ports that cascade matrix KVM switches. However, if a KVM port cascades a non-matrix KVM switch, you must assign access rights for a group to both that KVM port and those on the cascaded KVM switch. When you assign access rights for a group to a KVM port that cascades a Matrix Plus KVM adapter cable, the access rights apply to all KVM adapter cables in the chain.

To manage port access rights for a group:

1. In the **Group Management** screen, select a group name from the list, and then click **Modify**. The **Group Information** screen appears. (If you have already completed this step, skip to Step 2.)

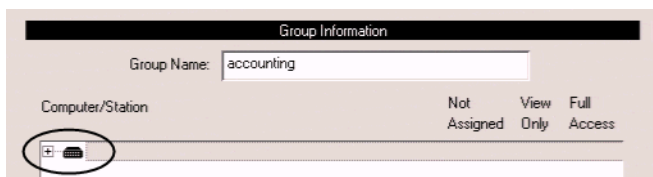

2. In the **Computer/Station** box, click the plus sign or double-click the root station icon to expand the ports. The tree expands to reveal the ports of the root station.

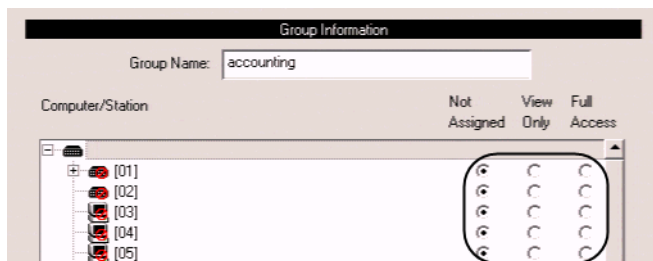

- Click to apply the type of access rights you wish to assign for the group to each port. The station/port icon changes according to the type of access right assigned.

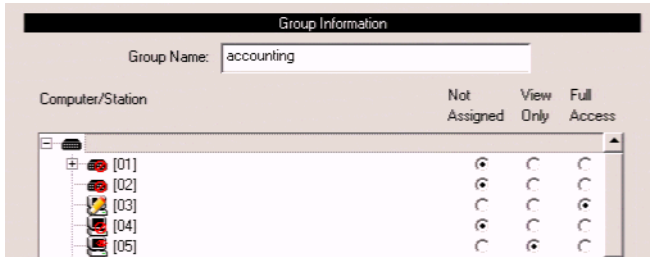

- If there are cascaded stations, expand those as well and apply access rights to the cascaded ports.

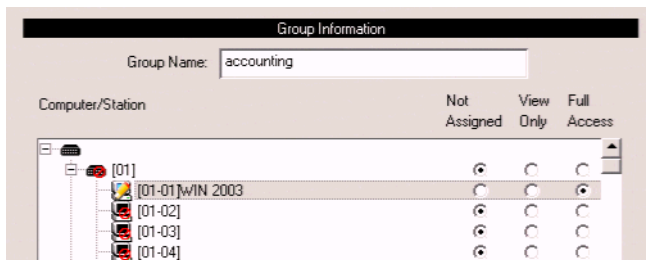

- Click **Save** to store your changes.
- To exit without saving changes, click any other menu or icon.

## User Management

---

Super Administrators and Administrators can add, modify, and delete users. Super Administrators can manage all user account types, while Administrators can manage other Administrators and Users. Up to 1024 unique user accounts can be created on the matrix KVM switch with no restriction on the number of any particular user type. In order for users to access the matrix KVM switch through the local console OSD or through the KM0832 Administrator Utility each user must have a user account. For each user account you must assign a username, password, user type, and group membership. Each user requires a valid username and password or the user will not be allowed to access the matrix KVM switch either through the KM0832 Administrator Utility or through the local console OSD.

When creating user accounts you must add each user to a group. Therefore, we suggest that you create groups before users. If you do not wish to create groups you may add users to the default group account. However, the default group account cannot be used to grant port access to group members. In this case, you must individually add users to the port(s).

The User Management screen is similar to the Group Management screen. It shows all users that have been created on the matrix KVM switch and their individual group memberships. It also provides options for creating new users and modifying or deleting existing users.

To access the User Management screen:

From the **Administration** menu, choose **Account Management > User Management**. The **User Management** screen appears.

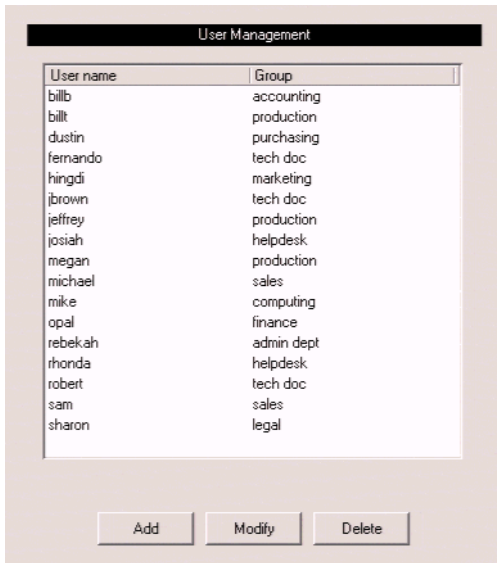



## Adding Users

To add a user account:

1. In the **User Management** screen, click **Add**. The **User Information** screen appears.

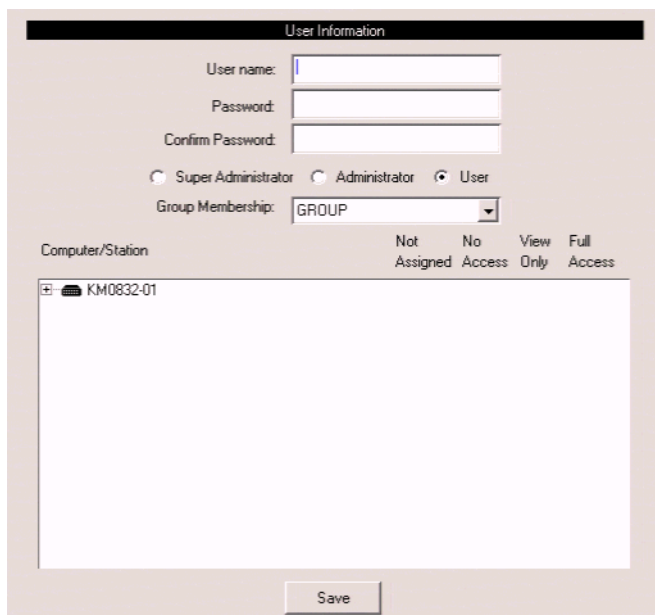

The screenshot shows a web form titled "User Information". It contains the following fields and options:

- User name: [Text input field]
- Password: [Text input field]
- Confirm Password: [Text input field]
- Role selection:  Super Administrator,  Administrator,  User
- Group Membership: [Dropdown menu showing "GROUP"]
- Computer/Station: [Table with columns for access levels]
- Save: [Button]

Computer/Station	Not Assigned	No Access	View Only	Full Access
<input type="checkbox"/> KM0832-01				

2. Type a name in the **User name** field. Usernames may be up to 15 characters long. Legal characters include: A–Z, 0–9, space, hyphen, square brackets, parentheses, and period.
3. Enter a password and then reenter the password to confirm it. Passwords may be up to 15 characters long. Legal characters include: A–Z, 0–9, space, hyphen, square brackets, parentheses, and period. This field may not be left blank.

4. Select an account type for the user.

Permission	User	Administrator	Super Administrator
Access ports*	•	•	•
Configure personal profile settings	•	•	•
Search	•	•	•
View online Help	•	•	•
Manage user/ administrator accounts		•	•
Manage super administrator accounts			•
Manage stations		•	•
Manage ports		•	•
View/clear log file		•	•
Manage group accounts			•
Configure network settings			•
View system information			•
Upgrade firmware			•
Invoke Broadcast mode			•

---

\* Super administrators and administrators have full access to all ports; however, users must be granted permission to access each port.

---

5. Select a group membership for the user. If you do not wish to create a group membership for the user, select the default GROUP account.
6. If you want to assign port access rights for the user, see *Managing Port Access Rights for Groups*, page 47.
7. Click **Save** to add the new user to the matrix KVM switch.
8. To exit without saving changes, click any other menu or icon.

## **Modifying Users**

To edit a user account:

1. In the **User Management** screen, select a username from the list, and then click **Modify**. The **User Information** screen appears.
2. Edit the user information, and then click **Save**. (Leave the password fields blank to keep the same password.)
3. To exit without saving changes, click any other menu or icon.

## **Deleting Users**

To delete a user account:

1. In the **User Management** screen, select a username from the list, and then click **Delete**. The user is removed from the list.
2. To exit without saving changes, click any other menu or icon.

## **Managing Port Access Rights for Users**

Super Administrators and Administrators can manage port access rights for Users from the User Information screen. (You do not need to assign port access rights for Super Administrators and Administrators. They have access to all KVM ports in the matrix KVM switch installation, including those in cascaded KVM switches.)

Please note that you do not need to assign access rights for a user to KVM ports that cascade matrix KVM switches. However, if a KVM port cascades a non-matrix KVM switch, you must assign access rights for a user to both that KVM port and those on the cascaded KVM switch. When you assign access rights for a user to a KVM port that cascades a Matrix Plus KVM adapter cable, the access rights apply to all KVM adapter cables in the chain.

To manage port access rights for a user:

1. In the **User Management** screen, select a username from the list, and then click **Modify**. The **User Information** screen appears.

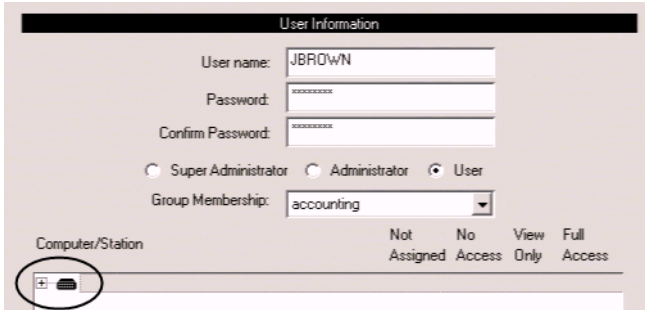

The screenshot shows the "User Information" dialog box. The "User name" field contains "JBR0wN". The "Password" and "Confirm Password" fields are masked with asterisks. The "Role" section has three radio buttons: "Super Administrator", "Administrator", and "User", with "User" selected. The "Group Membership" dropdown menu is set to "accounting". Below the form is a table with the following headers: "Computer/Station", "Not Assigned", "No Access", "View Only", and "Full Access". A circled plus sign icon is located in the "Computer/Station" column.

2. In the **Computer/Station** box, click the plus sign or double-click the root station icon to expand the ports. The tree expands to reveal the ports of the root station.

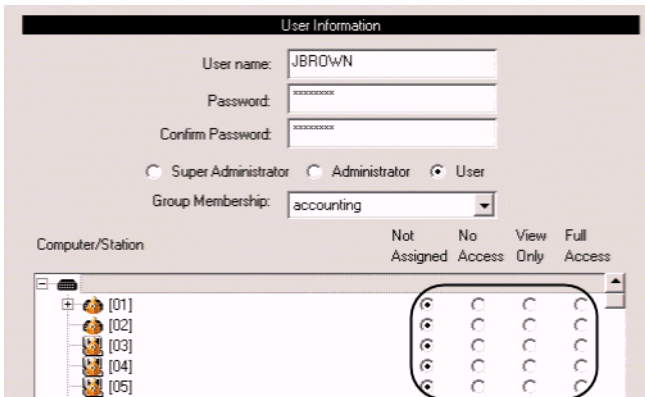

This screenshot shows the same "User Information" dialog box as above, but the "Computer/Station" tree is expanded. The tree shows a root station icon with a plus sign, and five sub-items labeled "[01]", "[02]", "[03]", "[04]", and "[05]". A circled area highlights a grid of access control checkboxes for each of these sub-items. The grid has four columns corresponding to the headers "Not Assigned", "No Access", "View Only", and "Full Access".

- Click to apply the type of access rights you wish to assign for the user to each port. The station/port icon changes according to the type of access right assigned.

The screenshot shows the 'User Information' dialog box. The 'User name' field contains 'JBROWN'. The 'Password' and 'Confirm Password' fields are masked with asterisks. The 'Group Membership' dropdown is set to 'accounting'. The role 'User' is selected with a radio button. Below this is a table with columns for 'Computer/Station' and four access rights: 'Not Assigned', 'No Access', 'View Only', and 'Full Access'. Each cell in the table contains a radio button.

Computer/Station	Not Assigned	No Access	View Only	Full Access
[01]	<input checked="" type="radio"/>	<input type="radio"/>	<input type="radio"/>	<input type="radio"/>
[02]	<input type="radio"/>	<input type="radio"/>	<input type="radio"/>	<input checked="" type="radio"/>
[03]	<input type="radio"/>	<input type="radio"/>	<input type="radio"/>	<input type="radio"/>
[04]	<input checked="" type="radio"/>	<input type="radio"/>	<input type="radio"/>	<input type="radio"/>
[05]	<input type="radio"/>	<input type="radio"/>	<input checked="" type="radio"/>	<input type="radio"/>

- If there are cascaded stations, expand those as well and apply access rights to the cascaded ports.

This screenshot is similar to the previous one, but the tree view under 'Computer/Station' is expanded. The sub-station '[01-01] WIN 2003' is highlighted, and its access rights are: 'Not Assigned' (radio checked), 'No Access' (radio), 'View Only' (radio), and 'Full Access' (radio checked). Other sub-stations [01-02], [01-03], and [01-04] are also visible with their respective radio buttons.

Computer/Station	Not Assigned	No Access	View Only	Full Access
[01]	<input checked="" type="radio"/>	<input type="radio"/>	<input type="radio"/>	<input type="radio"/>
[01-01] WIN 2003	<input checked="" type="radio"/>	<input type="radio"/>	<input type="radio"/>	<input checked="" type="radio"/>
[01-02]	<input checked="" type="radio"/>	<input type="radio"/>	<input type="radio"/>	<input type="radio"/>
[01-03]	<input checked="" type="radio"/>	<input type="radio"/>	<input type="radio"/>	<input type="radio"/>
[01-04]	<input checked="" type="radio"/>	<input type="radio"/>	<input type="radio"/>	<input type="radio"/>

- Click **Save** to store your changes.
- To exit without saving changes, click any other menu or icon.

## Port Management

---

The matrix KVM switch port access rights for Users and groups are set on a port-by-port basis, giving administrators a high degree of control over which ports users can access and how they access the ports. To enable Users to access ports, you must first configure the user access rights for each port. By default, all Super Administrators and Administrators have full access to all ports.

---

**Note:** Adding users to groups streamlines port configuration by allowing you to assign port access to entire groups at one time.

---

In this section we will discuss how to:

- ◆ Set port access rights for users and groups
- ◆ Configure port settings and assign names to ports
- ◆ Restore port defaults

## **Accessing Ports**

All ports in the station are listed on the Port Select screen.

To open the Port Select screen:

1. In the tree view, click on a station to select it.
2. From the **Administration** menu, choose **Port Management**. The **Port Select** screen appears.

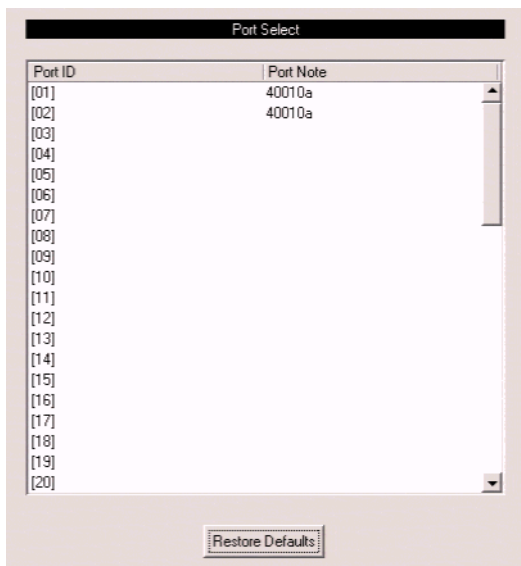

The Port Select screen is divided into two columns. Port IDs, or port numbers, are listed in the column on the left in ascending order. If a port has been named, the name appears to the right of the Port ID in the Port Note column. Click on a port entry to access the Port Management screen for that port.

## Managing Port Access

Each port has an individual Port Management screen that is used to set port access rights, assign port names and configure other port settings. This also is true for cascaded child stations.

To open the Port Management screen for a port:

1. In the matrix KVM switch tree (on the left side of the main screen), click on a computer icon. Each computer icon corresponds to a port. The **Port Management** screen for that port appears. (See *Tree View Icons*, page 17, for more information about using the computer icons.)

-or-

Open the **Port Select** screen. Go to Step 2.

2. Click on a port entry to open the **Port Management** screen for that port. The **Port Management** screen appears.

The screenshot displays the 'Port Management' interface. It is divided into several sections:

- Port Access:** A header section.
- Available Users:** A list box containing 'JOEL', 'dustin', and 'josiah'. To its right are '>' and '<' buttons.
- No Access Users:** An empty list box.
- View Only Users:** An empty list box.
- Full Access Users:** An empty list box.
- Available Groups:** A list box containing 'accounting', 'admin dept', 'computing', 'finance', 'helpdesk', 'legal', 'marketing', 'production', 'purchasing', and 'sales'. To its right are '>' and '<' buttons.
- View Only Groups:** An empty list box.
- Full Access Groups:** An empty list box.
- Port Settings:** A section on the right containing:
  - Port Note:** An empty text input field.
  - OS Language:** A dropdown menu currently set to 'English'.
  - Port OS:** A dropdown menu currently set to 'Win'.
- Save:** A button at the bottom right.



The Port Access area of the Port Management screen is used to manage port access rights for users and groups. The boxes on the left side of the screen show all users and groups that have been created. The boxes on the right side of the screen govern port access rights. These boxes are discussed in the table below.

In the middle of the screen are five sets of arrows. Each set contains two arrows: one facing leftward (<) and the other facing rightward (>), which correspond to the boxes immediately to the left and right, respectively. Arrows are used to move users and groups from the boxes on the left into the boxes on the right and vice versa.

Box Name	Description
Available Users	Lists users who have not been assigned access rights for the KVM port.
Available Groups	Lists groups that have not been assigned access rights for the KVM port.
No Access Users	Lists users who are restricted from access to the KVM port. If a user listed in this box is a member of a group that has permission to access the KVM port, placing the user in this box restricts the user from accessing the KVM port.
View Only Users	Lists users who are permitted to view video from the KVM port.
Full Access Users	Lists users who are permitted both to view video from the KVM port and to control it. If the KVM port cascades a KVM switch, the user will not be able to access KVM ports on that station until granted access rights to the individual KVM ports.
View Only Groups	Lists groups that are permitted to view video from the KVM port.
Full Access Groups	Lists groups that are permitted both to view video from the KVM port and to control it. If the KVM port cascades a KVM switch, the group will not be able to access the KVM ports of that station until granted access rights to the individual KVM ports.

- Note:**
1. You cannot add more than 32 users and 32 groups to a port. If you need to add more than 32 users to a port, first add the users to groups and then add those groups to the port.
  2. If a user is granted both user and group access rights to the same port, the user access rights will be applied and not those of the group.

To grant port access rights to users or groups:

1. Open the **Port Management** screen for the port where you wish to grant access rights.
2. In the **Available Users** box, click on a username to highlight it.

-or-

In the **Available Groups** box, click on a group name to highlight it.

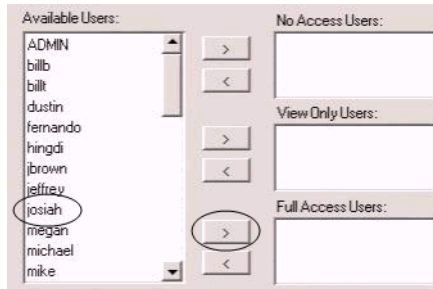

Click the appropriate rightward facing arrow (>) to move the selected user (or group) to the box on the right that corresponds to the access rights that you wish to grant to the user (or group). The user (or group) appears in the access rights box.

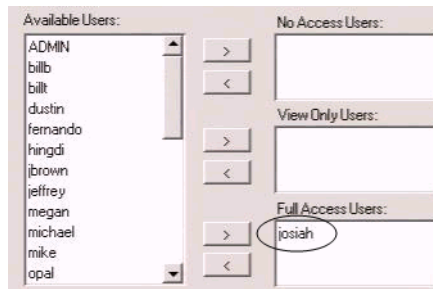

3. Repeat this procedure until you have assigned port access rights (or restrictions) for all users and groups.

If you make a mistake by adding a user or group to the wrong access rights box, simply highlight the username (or group name) again and then click

the corresponding leftward facing arrow. The selected user (or group) is removed from the box and put back into its former position.

4. Click **Save**. The selected users (or groups) are given the permissions that were assigned in the last step.
5. To exit without saving changes, click any other menu or icon.

## **Cascaded Installations**

Super administrators and administrators have full access to all KVM ports in the installation. You must assign access rights to KVM ports for all other users and groups. You do not need to assign access rights for users and groups to KVM ports that cascade other matrix KVM switch. However, if a KVM port cascades a non-matrix KVM switch, you must assign access rights for users and groups to both that KVM port and those on the cascaded KVM switch. When you assign access rights for users and groups to a KVM port that cascades a Matrix Plus KVM adapter cable, the access rights apply to all KVM adapter cables in the chain.

## Configuring Port Settings

Before you configure port settings, first verify that the KVM adapter cable for the KVM port you wish to configure is connected to the correct KVM port on the back panel of the matrix KVM switch. The other fields on the Port Management screen are described in the table below. (These fields do not appear if a cascaded KVM switch is connected to the port.)

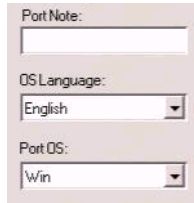

Port Note:

OS Language:  
 English ▾

Port OS:  
 Win ▾

Field	Description
Port Note	<p>Type a name in the <b>Port Note</b> field. Port notes may be up to 15 characters long. Legal characters include: a–z, A–Z, 0–9, space, and hyphen. Enter a unique note for the port that will differentiate it from all other ports in the KVM installation. The port note will appear on the Port Status and Port Select screens, and in the KA9233 tree next to the computer icon.</p> <ul style="list-style-type: none"> <li>◆ If the KVM port cascades a matrix KVM switch, the port note is replaced by the station name of the cascaded matrix KVM switch. To modify station names, see <i>Naming Stations</i>, page 37.</li> <li>◆ If a non-matrix KVM switch or a computer is connected to the KVM port by a KVM adapter cable, the port note can be changed. If the position of the KVM switch or the computer in the KVM installation ever changes, the port note for the new KVM port will automatically change to the port note stored in the KVM adapter cable. However, the port note for the old KVM port must be erased manually.</li> <li>◆ If nothing is connected to the KVM port, the port note can be changed. However, if a cascaded KVM switch or KVM adapter cable is attached to the port later, the port note will change to the port note stored in the KVM adapter cable.</li> </ul>

*(continues on next page)*

(continued from previous page)

Field	Description
Keyboard Layout (OS Language)	Set the layout of the keyboard(s) that will be used to access the computer attached to this port. The matrix KVM switch supports 3 keyboard layouts: U.S. English, Japanese, and French. Configuring this setting correctly will ensure that characters are entered correctly and that the special keys on Japanese keyboards work correctly (if applicable).
Keyboard (Port OS)	Set the model of the keyboard(s) that will be used to access the computer attached to this port. The matrix KVM switch supports 3 keyboard models: IBM PC (101/104 keys), Apple, and Sun. Configuring this setting correctly will ensure that the special keys on Apple and Sun keyboards work correctly (if applicable).

## **Restoring Port Defaults**

Clicking the Restore Defaults button at the bottom of the Port Select screen restores KVM port defaults. When restoring port defaults, port access rights are revoked for users and groups, port notes are removed, and the Port Operating System and Port Language settings are restored to the original factory default settings. (See *Factory Default Settings*, page 78.)

In cascaded installations, you can restore port defaults for up to 2 levels of KVM switches at a time. If you want to restore port defaults for more than two levels of KVM switches, repeat this procedure for each third-level KVM switch for which you wish to restore port defaults. Port defaults will be restored for any fourth-level KVM switches at the same time.

---

**Note:** You cannot restore port defaults for daisy-chained KM0432.

---

To restore port defaults for up to two levels of KVM switches:

1. In the tree view, click on the station for which you want to restore port defaults to select it.
2. From the **Administration** menu, choose **Port Management**. The **Port Select** screen for that station appears.
3. Click **Restore Defaults**. The port defaults are restored for the selected station and one additional level of cascaded KVM switches (if applicable).

## Searching for Ports and Stations

---

The Search function provides a convenient method to easily locate ports and cascaded stations by Port Note or Station Name.

To search for a port:

1. Click the **Search** menu. The **Search** screen opens.



2. In the field, enter the Port Note of the port for which you are searching; or, enter the Station Name of a cascaded station. All entries that match or contain the search term(s) appear in a list.

---

**Note:** You do not need to enter the entire Port Note; a partial Port Note is acceptable. For example, if you want to search for a port with Port Note **WIN 2K AS**, you only need enter a portion of the Port Note, i.e. **WIN**. The same applies when searching for stations.

---

3. Click **Search**.
4. To exit without searching, click any other menu or icon.

## Upgrading Firmware

Super Administrators can upgrade firmware for the KA9233. As new versions of the KA9233 firmware become available, they can be downloaded from our Website. Check the Website regularly to find the latest information and firmware upgrade packages.

### Preparing to Upgrade the Firmware

To prepare to upgrade the firmware:

Connect the firmware upgrade cable to a COM port on the computer you used to download the upgrade package and to the F/W UPGRADE port on the KA9233.

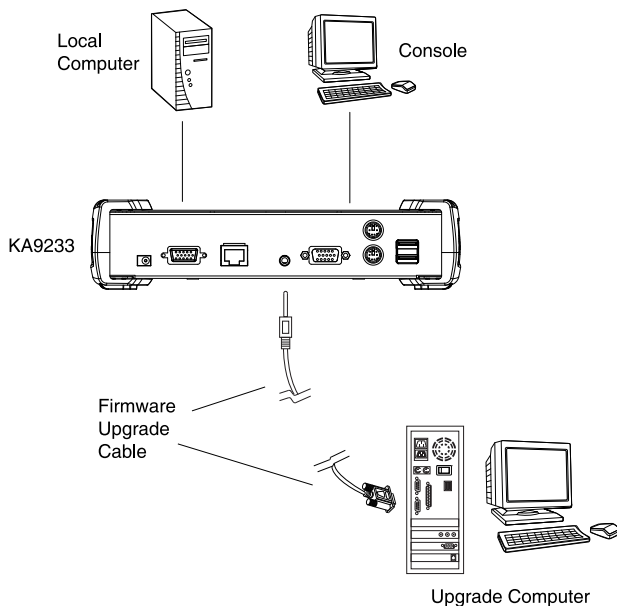

## **Downloading the Firmware Upgrade Package**

To download the firmware upgrade package:

1. From a computer that is not part of your KVM installation go to our Website and choose the model name that relates to your device. A list of available firmware upgrade packages appears.
2. Choose the firmware upgrade package that you wish to install (usually the most recent) and download it to your computer.

## **Upgrading the Firmware**

To upgrade the firmware:

1. Log in to the Graphical OSD (see *Logging in to the Graphical OSD*, page 15).
2. Click the **Upgrade** icon. The following dialog box appears:

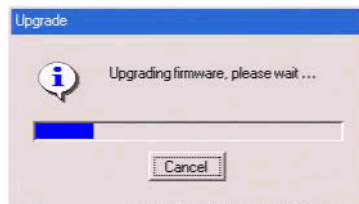



- Double-click the **KA9233 Firmware Upgrade Utility** icon. The **Firmware Upgrade Utility** welcome screen appears.

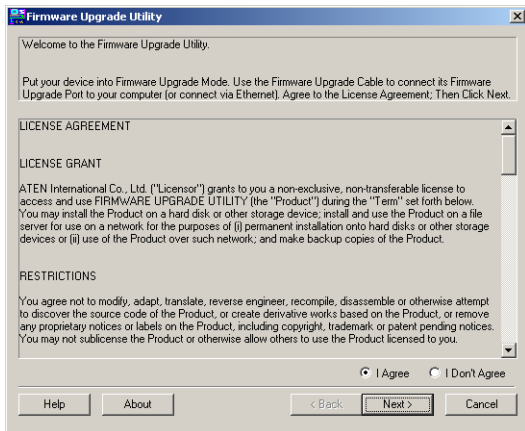

- Read the license agreement, and then click **I Agree**.
- Click **Next** to continue. The **Firmware Upgrade Utility** main screen appears.

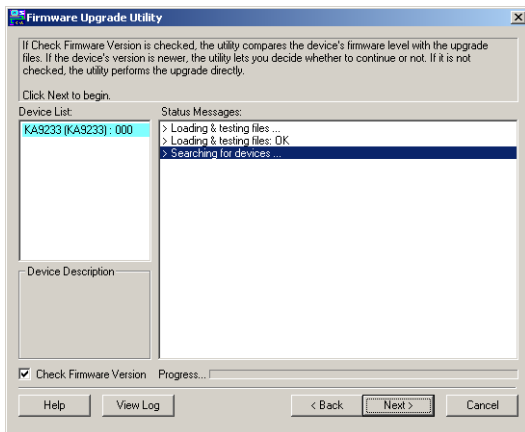

The Utility inspects your installation. All devices capable of being upgraded by the package are listed in the **Device List** box.

6. Select a device in the **Device List** box to display information about it in the **Device Description** panel.

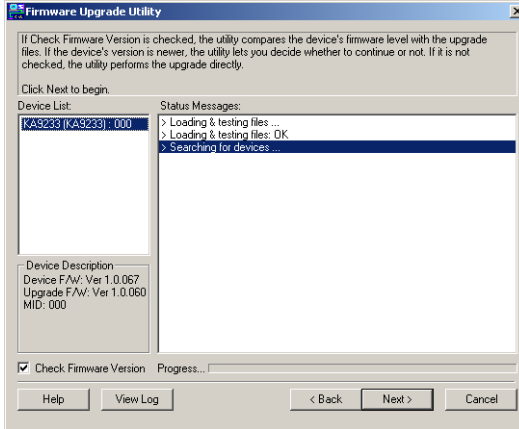

7. Select the **Check Firmware Version** check box if you wish to compare the current firmware version level of the KA9233 to that of the Firmware Upgrade Utility installation files. Click **Next** to begin upgrading the firmware. If the KA9233's firmware version level is equal to or higher than that of the installation files, the following dialog box appears to give you the option to abort the operation:

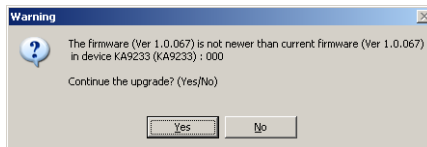

8. Click **Yes** to begin upgrading the firmware; or, click **No** to abort the operation.

If you chose not to check the firmware version, the Firmware Upgrade Utility installs the upgrade files without comparing the firmware version levels.

- As the Upgrade proceeds, status messages appear in the **Status Messages** box, and the progress toward completion is shown on the **Progress** bar.

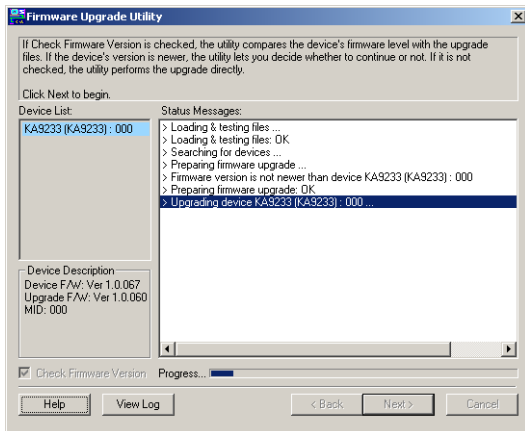

- After the upgrade is finished, a message appears at the top of the screen to inform you that the firmware was successful upgraded:

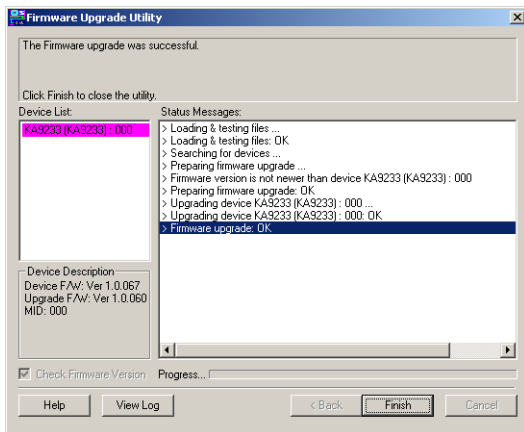

11. Click **Finish** to close the Firmware Upgrade Utility. The following dialog box appears in the KA9233 Graphical OSD:



12. Click **OK**. The KA9233 will reset automatically.

### **Upgrade Failed**

If the firmware upgrade fails to complete successfully, then follow this procedure to restart the upgrade:

1. Click **Finish** to quit upgrading the firmware.
2. Start the firmware upgrade procedure again (see *Upgrading the Firmware*, page 66).

## Viewing and Clearing the Log File

---

The log file is a record of events that happen in the Graphical OSD. It records events such as logins and logouts. Each entry is recorded with the date and time at which the event happened. Only Super Administrators and Administrators can view and clear the log file.

To view the log file:

1. Click the **Log** icon. The **Event Log** screen appears.

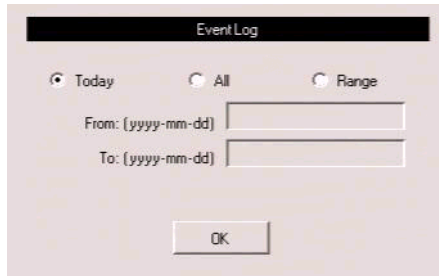

2. Select one of the following three ways to view log file events:
  - ◆ Today: Select this option to view only events that happened today.
  - ◆ All: Select this option to view all events in the log file.
  - ◆ Range: Select this option to view events that happened over a period of one or more days. Enter the beginning date in the **From** field and the ending date in the **To** field. Enter the date in Arabic numerals, year first, then the month, followed by the day. The year must carry four digit places, while the month and day each must carry two digit places. The year, month, and day each must be separated by a hyphen. For example, December 5th, 2005, should be written *2005-12-05*.

3. Click **OK**. The **System Log** screen appears.

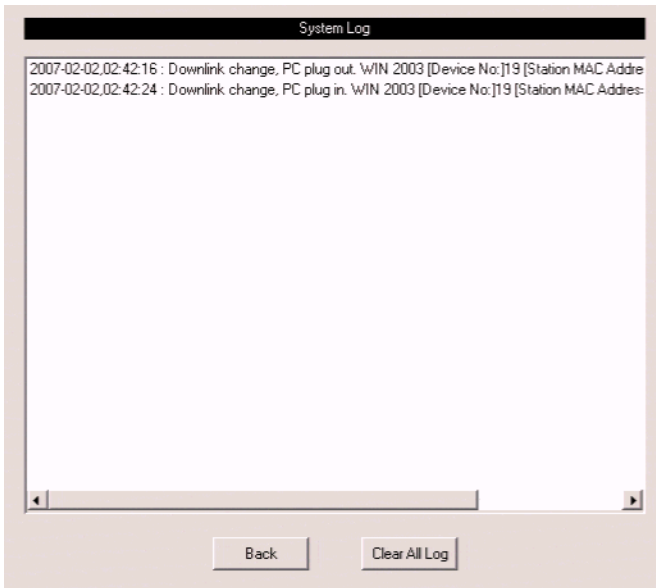

Each line in the log file is a record of an event that occurred in the KA9233 during the time specified on the Event Log screen.

4. Click **Back** to return to the **Event Log** screen.

To clear the contents of the log file:



If you delete the contents of the log file you cannot recover them; however, this will not affect future log events.

1. Follow Steps 1–3 for viewing the log file.
2. At the bottom of the **System Log** screen, click **Clear All Log**. All events in the log file are deleted.
3. To exit without clearing the log file, click any other menu or icon.

## Broadcasting Commands

---

In Broadcast mode, super administrators can broadcast commands from the KVM console keyboard to all available computers in the installation. Broadcast mode is particularly useful for operations that need to be performed on multiple computers, such as performing a system wide shutdown, installing or upgrading software, etc.

While Broadcast mode is in effect:

- ◆ A *speaker* symbol appears before the port ID display of the KVM port that currently has the KVM console focus.
- ◆ Other KVM consoles will not be able to control the computers; however, they will be able to access the KVM ports to view the computers.
- ◆ Mouse commands will not be broadcast.
- ◆ A message displays across the bottom of the super administrator's screen that Broadcast mode is in effect.
- ◆ If the super administrator that invoked Broadcast mode is idle for longer than the period of time set with the Idle Timeout function, Broadcast mode is canceled. (See *Set Idle Timeout*, page 28, for details.)
- ◆ If the super administrator that invoked Broadcast mode invokes the OSD for more than 30 seconds, Broadcast mode is canceled.

To enable Broadcast mode:

1. From the **Administration** menu, choose **Super Adm Configuration > Broadcast**. The **Broadcast** screen appears.

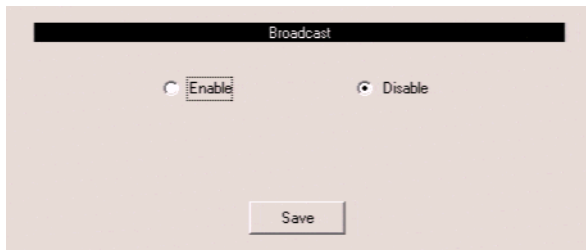

2. Select **Enable**, and then click **Save**. Broadcast mode is enabled.

To exit Broadcast mode:

1. Open the Graphical OSD.
2. From the **Administration** menu, choose **Super Adm Configuration > Broadcast**. The **Broadcast** screen appears.
3. Select **Disable**, and then click **Save**. Broadcast mode is disabled.

## Viewing System Information

---

Super Administrators can view information about the KA9233 system through the System Information screen. It shows device model number and the firmware version.

To view system information:

1. From the **Administration** menu, choose **Super Adm Configuration > System Information**. The **System Information** screen appears.

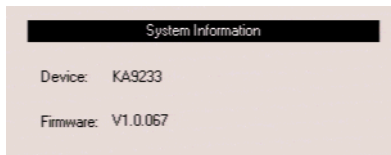











# Chapter 6

## Keyboard Emulation

### Apple Keyboard

---

The IBM PC keyboard (101/104 keys) can emulate the functions of the Apple keyboard. The emulation mappings are listed in the table below.

PC Keyboard	Apple Keyboard
[Shift]	Shift
[Ctrl]	Ctrl
	
[Ctrl] [1]	
[Ctrl] [2]	
[Ctrl] [3]	
[Ctrl] [4]	
[Alt]	Alt
[Print Screen]	F13
[Scroll Lock]	F14
	=
[Enter]	Return
[Backspace]	Delete
[Insert]	Help
[Ctrl] 	F15







---

**Note:** When using key combinations, press and release the first key (Ctrl), then press and release the activation key.

---

## Sun Keyboard

The IBM PC keyboard (101/104 keys) can emulate the functions of the Sun keyboard. The emulation mappings are listed in the table below.

PC Keyboard	Sun Keyboard
[Ctrl] [T]	Stop
[Ctrl] [F2]	Again
[Ctrl] [F3]	Props
[Ctrl] [F4]	Undo
[Ctrl] [F5]	Front
[Ctrl] [F6]	Copy
[Ctrl] [F7]	Open
[Ctrl] [F8]	Paste
[Ctrl] [F9]	Find
[Ctrl] [F10]	Cut
[Ctrl] [1]	
[Ctrl] [2]	
[Ctrl] [3]	
[Ctrl] [4]	
[Ctrl] [H]	Help
	Compose
	

- Note:**
1. When using key combinations, press and release the first key [Ctrl], then press and release the activation key.
  2. If you are using a PC keyboard and want to use Stop-A keys to enter the ok prompt, see *Entering the ok Prompt (Sun Solaris)*, page 78.

# Appendix

## Specifications

Function		KA9233	
Computer Connections		1	
Console Connections		1	
Port Selection		Graphical OSD, Hotkey	
Connectors	Console Port	Keyboard	1 x USB Type A Female (White) 1 x 6-pin Mini-DIN Female (Purple)
		Video	1 x HDB-15 Female (Blue)
		Mouse	1 x USB Type A Female (White) 1 x 6-pin Mini-DIN Female (Green)
	KVM Port		1 x SPHD-15 Female (Yellow)
	F/W Upgrade		1 x 4-conductor 3.5mm Jack
	Power		1 x DC Jack (Black)
	Link		1 x RJ-45 Female (Black)
Switches	Local/Remote		1 x Pushbutton
	Video Gain Adjustment		2 x Pushbutton
LEDs	Link		1 (Green)
	Local		1 (Orange)
	Remote		1 (Orange)
Emulation	Keyboard/Mouse		PS/2; USB (PC, Sun, Apple)
Video		1024 x 768 @ 60Hz (300m max.)	
Scan Interval		1–240 Seconds	
Power Consumption		DC 5.3V, 6W	
Environment	Operating Temp.		0–50° C
	Storage Temp.		-20–60° C
	Humidity		0–80% RH, Non-condensing
Physical Properties	Housing		Metal
	Weight		1.20 kg
	Dimensions (L x W x H)		16.60 x 21.50 x 4.50 cm (19"/1U)

## Factory Default Settings

---

The factory default settings are as follows:

Setting	Default
View mode	Accessible + Powered
Port ID Tag mode	ID + Port Name
Port ID Position	Upper left
Display Duration	User Defined (3 seconds)
Scan Timer	5 seconds
Scan mode	Accessible + Powered
OSD Activation	[Scroll Lock] [Scroll Lock]
Logout Timeout	0 (Disabled)
Screen Blanker	0 (Disabled)
Hotkey Command	On
Beeper	On
Idle Timeout	5 seconds
Port Access	None (Super Administrators and Administrators have full access)
Port Note	None
Port OS Language	English
Port Operating System	Windows (PC compatible)
Webpage Session Timeout	3 minutes
DHCP Enabled	No (Disabled)
SMTP Server Mail Notification	No (Disabled)
Broadcast mode	Disabled

## Entering the ok Prompt (Sun Solaris)

---

If you are using a PC keyboard to control a Sun Solaris server and want to use Stop-A keys to enter the ok prompt, do the following:

**Note:** Before entering the ok prompt, consult the server's documentation for any precautionary steps that you should take.

---

Press and release [Ctrl], press and hold down [T], and then press [A].

---

---

## Troubleshooting

---

### General

Problem	Solution
I cannot use an Ethernet hub to connect the KA9233 to the matrix KVM switch.	Although Cat 5 cable is used to connect the KA9233 Console Module to the matrix KVM switch, it does not support the Ethernet protocol; thus, you cannot use an Ethernet hub to connect them.
I can't login to the matrix KVM switch.	<ol style="list-style-type: none"><li data-bbox="432 419 976 499">1. Make sure that the power adapter cable is plugged into the KA9233 and connected to an AC mains power source.</li><li data-bbox="432 499 976 563">2. Make sure that the keyboard is connected and functioning properly.</li><li data-bbox="432 563 976 643">1. Make sure that the Cat 5 cable is connected to the LINK port on the KA9233 and to a user port on the matrix KVM switch.</li><li data-bbox="432 643 976 734">2. Verify that the KM0832 firmware is version 1.2.114 or higher. If not, upgrade the KM0832 firmware to version 1.2.114 or higher.</li></ol>

## Sun Systems

Problem	Solution
<p>Video display problems with HDB-15 interface systems (e.g. Sun Blade 1000 servers).</p>	<p>The display resolution should be set to 1024 x 768 @ 60Hz.</p> <p>Under Text Mode:</p> <ol style="list-style-type: none"> <li>1. Enter the <code>ok</code> prompt (see page 78) and issue the following firmware commands:</li> </ol> <pre>setenv output-device screen:r1024x768x60 reset-all</pre> <p>Under XWindow:</p> <ol style="list-style-type: none"> <li>1. Open a console and issue the following command:</li> </ol> <pre>m64config -res 1024x768x60</pre> <ol style="list-style-type: none"> <li>2. Log out.</li> <li>3. Log in.</li> </ol>
<p>Video display problems with 13W3 interface systems (e.g. Sun Ultra servers).*</p>	<p>The display resolution should be set to 1024 x 768 @ 60Hz.</p> <p>Under Text Mode:</p> <ol style="list-style-type: none"> <li>1. Enter the <code>ok</code> prompt (see page 78) and issue the following firmware commands:</li> </ol> <pre>setenv output-device screen:r1024x768x60 reset-all</pre> <p>Under XWindow:</p> <ol style="list-style-type: none"> <li>1. Open a console and issue the following command:</li> </ol> <pre>ffbconfig -res 1024x768x60</pre> <ol style="list-style-type: none"> <li>2. Log out.</li> <li>3. Log in.</li> </ol>

\* These solutions work for most common Sun VGA cards. If these procedures fail to resolve the problem, consult the manual for the Sun VGA card.

---

## Limited Warranty

---

ATEN warrants this product against defects in material or workmanship for a period of one (1) year from the date of purchase. If this product proves to be defective, contact ATEN's support department for repair or replacement of your unit. ATEN will not issue a refund. Return requests can not be processed without the original proof of purchase.

When returning the product, you must ship the product in its original packaging or packaging that gives an equal degree of protection. Include your proof of purchase in the packaging and the RMA number clearly marked on the outside of the package.

This warranty becomes invalid if the factory-supplied serial number has been removed or altered on the product.

This warranty does not cover cosmetic damage or damage due to acts of God, accident, misuse, abuse, negligence or modification of any part of the product. This warranty does not cover damage due to improper operation or maintenance, connection to improper equipment, or attempted repair by anyone other than ATEN. This warranty does not cover products sold AS IS or WITH FAULTS.

IN NO EVENT SHALL ATEN'S LIABILITY EXCEED THE PRICE PAID FOR THE PRODUCT. FURTHER, ATEN SHALL NOT BE RESPONSIBLE FOR DIRECT, INDIRECT, SPECIAL, INCIDENTAL OR CONSEQUENTIAL DAMAGES RESULTING FROM THE USE OF THE PRODUCT, ITS ACCOMPANYING SOFTWARE, OR ITS DOCUMENTATION. ATEN SHALL NOT IN ANY WAY BE RESPONSIBLE FOR, WITHOUT LIMITATION, LOSS OF DATA, LOSS OF PROFITS, DOWNTIME, GOODWILL, DAMAGE OR REPLACEMENT OF EQUIPMENT OR PROPERTY, AND ANY EXPENSES FROM RECOVERY, PROGRAMMING, AND REPRODUCTION OF ANY PROGRAM OR DATA.

ATEN makes no warranty or representation, expressed, implied, or statutory with respect to its products, contents or use of this documentation and all accompanying software, and specifically disclaims its quality, performance, merchantability, or fitness for any particular purpose.

ATEN reserves the right to revise or update its product, software or documentation without obligation to notify any individual or entity of such revisions, or update.

For details about extended warranties, please contact one of our dedicated value added resellers.

This Page Intentionally Left Blank



# Index

## A

- accessing target devices, 22
- accounts, managing, 44, 49
- activating the Graphical OSD, 28
- adjusting picture quality, 14

### Apple

- keyboard emulation, 75
- keyboards, 63

### Auto Scan mode

- invoking, 23, 34
- pausing, 23, 34
- setting port access, 26
- setting scan interval, 26, 33
- skipping ports, 23
- stopping, 23, 35

## B

- basic operation, 11
- beeper, 28, 35
- Broadcast mode, 73

## C

- cables, 3
- change password, 28
- computer, local, 13
- CPU module. *See* KVM adapter cable

## D

- date, setting, 42
- default settings, factory, 78
- desktop mounting, 7

## E

- e-mail notification, 41
- emulation, keyboard

- Apple, 75

- Sun, 76

- English keyboard layout, 63

- Event Log, 71

## F

- F/W UPGRADE port, 5
- factory default settings, 78
- FCC Information, ii
- firmware, upgrading, 65
- French keyboard layout, 63

## G

- Graphical OSD, 16
  - OSD hotkey, 22, 28
  - shortcut keys, 17
- Group Management, 44

## H

- Help, 29
- hot plugging, 11
- Hotkey mode, 28
  - beeper control, 35
  - invoking, 31
  - port control, 31
  - port selection, 32
  - summary table, 36
- hotkey, OSD, 22, 28

## I

- icons, 16
- Idle Timeout, 28
- installing the KA9233, 10
- invoking Hotkey mode, 31
- IP address, assigning
  - in IP Installer, 39
  - in the Graphical OSD, 40

IP Installer, 39

## J

Japanese keyboard layout, 63

## K

KA9233

front view, 4

rack mounting, 7

rear view, 5

stacking, 7

keyboard emulation

Apple, 75

Sun, 76

keyboard layout, 63

keyboards, 63

KVM adapter cable, 62

## L

LINK LED, 4, 11

LINK port, 5

local computer switching, 13

LOCAL LED, 4, 13

LOCAL PC port, 5, 13

LOCAL/REMOTE button, 4, 13

Log File, 71

logging in, 15

logging out, 29

Logout Timeout, 28

## M

Macintosh. *See* Apple

menus, 16

## N

naming stations, 37

Network Settings, 39

notification messages, 41

## O

Online

Registration, iii

Support, iii

OSD hotkey, 22, 28

OSD. *See* Graphical OSD

Overview, 1

## P

password, changing, 28

picture quality, adjusting, 14

port access, managing, 47, 53, 58

port ID, 21

numbering, 19

Port Management, 56

port management, 56

port note, 21, 62

port settings, 62

Port Status, 21

port switching, 22

ports

F/W UPGRADE, 5

keyboard layout, 63

keyboards, 63

LINK, 5

LOCAL PC, 5, 13

## R

rack mounting, 7

safety instructions, vi

REMOTE LED, 4, 13

restoring port defaults, 63

RoHS, ii

## S

safety instructions

general, iv

rack mounting, vi

Screen Blanker, 28

---

Search, 64  
setting  
    Auto Scan mode interval, 33  
shortcut keys, 17  
SJ/T 11364-2006, ii  
Skip mode, 26, 34  
SMTP server settings, 41  
specifications, technical, 77  
stacking, 7  
stations, naming, 37  
Sun Microsystems  
    keyboard emulation, 76  
    keyboards, 63  
    ok prompt, 78  
    troubleshooting, 80  
switching ports, 22, 32  
system event report, 41  
System Information, 74  
system requirements  
    cables, 3  
    computers, 3  
    consoles, 3  
    operating systems, 3

**T**  
target devices, accessing, 22  
technical specifications, 77  
technical support, xiii  
time, setting, 42  
troubleshooting, 79  
    Sun Microsystems, 80

**U**  
upgrading firmware, 65  
user management, 49  
user notice, iii  
user settings, OSD, 27

**V**  
video gain buttons, 4, 14  
video quality, adjusting, 14  
View, 24

**W**  
Web Page Session Timeout, 38