

DELPHI SERIES



FEATURES

- High efficiency: 92.5 % @12V/18A
- Size: 57.9x36.8x10.8mm (2.28"x1.45"x0.43") (w/o heatspreader)
57.9x36.8x12.7mm (2.28"x1.45"x0.50") (with heatspreader)
- Industry standard pin out
- Fixed frequency operation
- Fully protected: OTP, OVP, OCP, UVLO
- No minimum load required
- Wide output trim range: -20~+10%
- Remote sense
- Fast transient response
- Basic insulation and 2250V isolation
- ISO 9001, TL 9000, ISO 14001, QS9000, OHSAS18001 certified manufacturing facility
- UL/cUL 60950-1 (US & Canada) recognized, TUV (EN60950-1) certified
- CE mark meets 73/23/EEC and 93/68/EEC directives

Delphi Series Q48SP, 216W Quarter Brick Family DC/DC Power Modules: 48V in, 12V/18A out

The Delphi Series Q48SP Quarter Brick, 48V input, 12V single output, isolated, DC/DC converters are the latest offering from a world leader in power systems technology and manufacturing — Delta Electronics, Inc. This product family provides up to 216 watts of power or up to 18A of output current in an industry standard footprint. With creative design technology and optimization of component placement, these converters possess outstanding electrical and thermal performance, as well as extremely high reliability under highly stressful operating conditions. All models are fully protected from abnormal input/output voltage, current, and temperature conditions. The Q48SP Delphi Series converters meet all safety requirements with basic insulation.

OPTIONS

- Latched over current protection
- Positive remote on/off
- Short lead lengths

APPLICATIONS

- Telecom/DataCom
- Wireless Networks
- Optical Network Equipment
- Server and Data Storage
- Industrial/Test Equipment

TECHNICAL SPECIFICATIONS

($T_A=25^{\circ}\text{C}$, airflow rate=300 LFM, $V_{in}=48\text{Vdc}$, nominal V_{out} unless otherwise noted; mounted on board.)

PARAMETER	NOTES and CONDITIONS	Q48SP12017NRFA			
		Min.	Typ.	Max.	Units
ABSOLUTE MAXIMUM RATINGS					
Input Voltage					
Continuous		-0.5		80	Vdc
Transient (100ms, non-operating)	100ms			100	Vdc
Operating Temperature	Refer to Figure 22 for the measuring point	-40		120	$^{\circ}\text{C}$
Storage Temperature		-40		105	$^{\circ}\text{C}$
Input/Output Isolation Voltage				2250	Vdc
INPUT CHARACTERISTICS					
Operating Input Voltage		36	48	75	Vdc
Input Under-Voltage Lockout					
Turn-On Voltage Threshold		33	34	36	Vdc
Turn-Off Voltage Threshold		30	32	34	Vdc
Lockout Hysteresis Voltage		1	2	3	Vdc
Maximum Input Current	100% Load, 36Vin			7	A
No-Load Input Current				140	mA
Off Converter Input Current				11	mA
Inrush Current (I^{\dagger})				1	A°S
Input Reflected-Ripple Current	P-P thru 12 μH inductor, 5Hz to 20MHz		10		mA
Input Voltage Ripple Rejection	120 Hz		50		dB
OUTPUT CHARACTERISTICS					
Output Voltage Set Point	$V_{in}=48\text{V}$, $I_o=I_{o,max}$, $T_a=25^{\circ}\text{C}$	11.8	12	12.2	Vdc
Output Voltage Regulation					
Over Load	$I_o=I_{o,min}$ to $I_{o,max}$		6	24	mV
Over Line	$V_{in}=36\text{V}$ to 75V		6	24	mV
Over Temperature	$T_a=-40^{\circ}\text{C}$ to 135°C		32	60	mV
Total Output Voltage Range	over sample load, line and temperature	11.6		12.4	V
Output Voltage Ripple and Noise	5Hz to 20MHz bandwidth				
Peak-to-Peak	Full Load, 1 μF ceramic, 10 μF tantalum			150	mV
RMS	Full Load, 1 μF ceramic, 10 μF tantalum			50	mV
Operating Output Current Range		0		18	A
Output DC Current-Limit Inception	Output Voltage 10% Low	19	21	24	A
DYNAMIC CHARACTERISTICS					
Output Voltage Current Transient	48V, 10 μF Tan & 1 μF Ceramic load cap, 0.1A/ μs				
Positive Step Change in Output Current	50% $I_{o,max}$ to 75% $I_{o,max}$		300		mV
Negative Step Change in Output Current	75% $I_{o,max}$ to 50% $I_{o,max}$		300		mV
Settling Time (within 1% V_{out} nominal)			400		μS
Turn-On Transient					
Start-Up Time, From On/Off Control			8		mS
Start-Up Time, From Input			6		mS
Maximum Output Capacitance	Full load; 5% overshoot of V_{out} at startup	0		1500	μF
EFFICIENCY					
100% Load			92.5		%
ISOLATION CHARACTERISTICS					
Input to Output				2250	Vdc
Isolation Resistance		10			M Ω
Isolation Capacitance			1000		pF
FEATURE CHARACTERISTICS					
Switching Frequency			300		kHz
ON/OFF Control, (Logic Low-Module ON)					
Logic Low	$V_{on/off}$ at $I_{on/off}=1.0\text{mA}$	0		1	V
Logic High	$V_{on/off}$ at $I_{on/off}=0.0\mu\text{A}$	2		15	V
ON/OFF Current	$I_{on/off}$ at $V_{on/off}=0.0\text{V}$			1	mA
Leakage Current	Logic High, $V_{on/off}=15\text{V}$			50	μA
Output Voltage Trim Range (not available on Exxx code)	Across Pins 9 & 5, $P_{out} \leq \text{max rated power}$	-20		+10	%
Output Voltage Remote Sense Range (not available on Exxx)	$P_{out} \leq \text{max rated power}$			0.5	V
Output Over-Voltage Protection	Over full temp range; % of nominal V_{out}	13.5		16.5	V
GENERAL SPECIFICATIONS					
MTBF	$I_o=80\%$ of $I_{o,max}$; $T_a=25^{\circ}\text{C}$		2.40		M hours
Weight			45		grams
Over-Temperature Shutdown	Refer to Figure 22 for the measuring point		130		$^{\circ}\text{C}$



ELECTRICAL CHARACTERISTICS CURVES

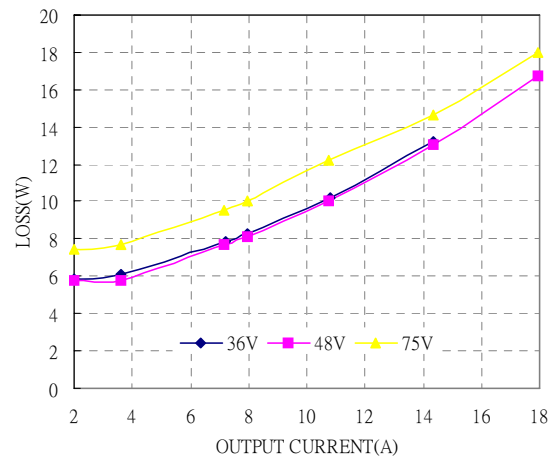
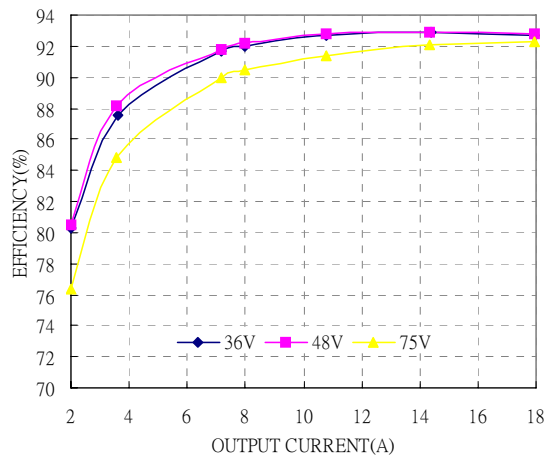

Figure 1: Efficiency vs. load current for minimum, nominal, and maximum input voltage at 25°C.

Figure 2: Power dissipation vs. load current for minimum, nominal, and maximum input voltage at 25°C.

22-Jun-05
13:53:33

22-Jun-05
13:59:43

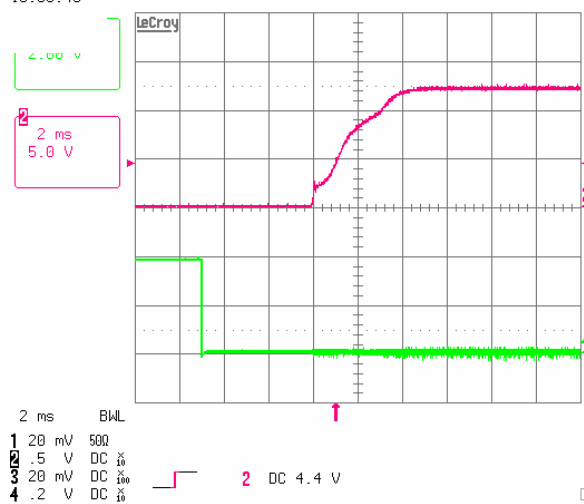
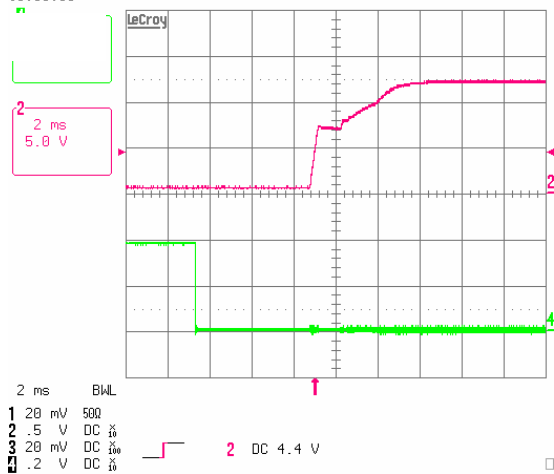

Figure 3: Turn-on transient at zero load current. Top Trace: Vout; 5V/div; Bottom Trace: ON/OFF input: 2V/div

Figure 4: Turn-on transient at load full rated current. Top Trace: Vout; 5V/div; Bottom Trace: ON/OFF input: 2V/div



ELECTRICAL CHARACTERISTICS CURVES

22-Nov-05
13:53:00

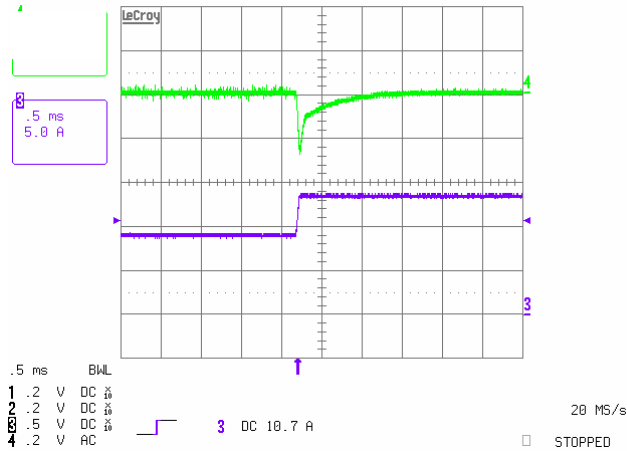

Figure 5: Output voltage response to step-change in load current (50%-75% of I_o , max: $di/dt = 0.1A/\mu s$). Load cap: $1\mu F$ ceramic capacitor and $10\mu F$ Tantalum capacitor. Top Trace: V_{out} (200mV/div), Bottom Trace: I_{out} (5A/div). Scope measurement should be made using a BNC cable (length shorter than 20 inches). Position the load between 51 mm to 76 mm (2 inches to 3 inches) from the module.

22-Nov-05
13:56:02

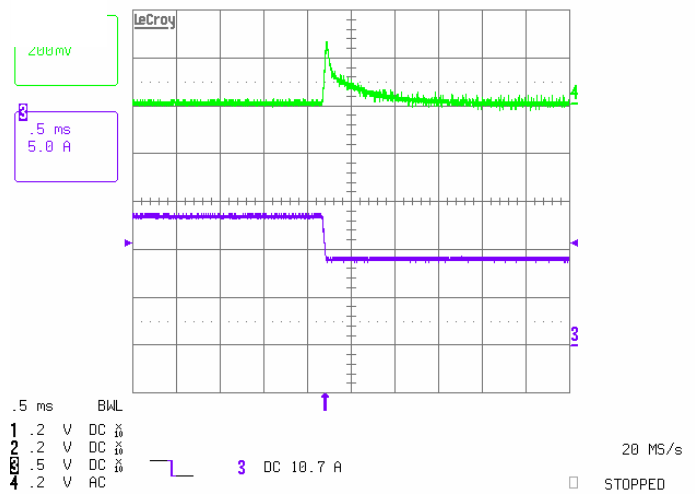

Figure 6: Output voltage response to step-change in load current (75%-50% of I_o , max; $di/dt = 0.1A/\mu s$). Load cap: $10\mu F$ tantalum capacitor and $1\mu F$ ceramic capacitor. Top Trace: V_{out} (200mV/div), Bottom Trace: I_{out} (5A/div). Scope measurement should be made using a BNC cable (length shorter than 20 inches). Position the load between 51 mm to 76 mm (2 inches to 3 inches) from the module..

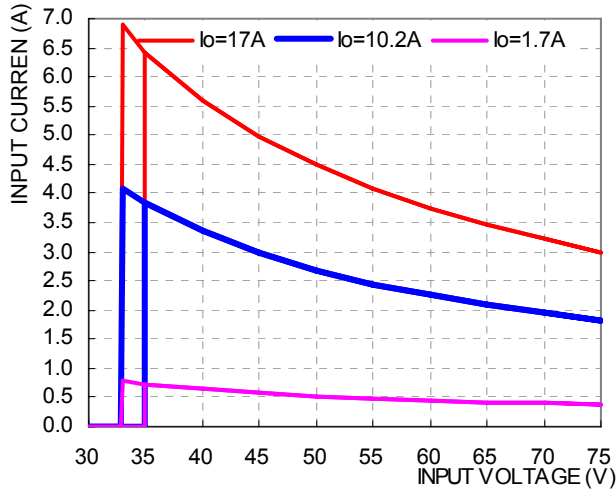

Figure 7: Typical input characteristics at room temperature

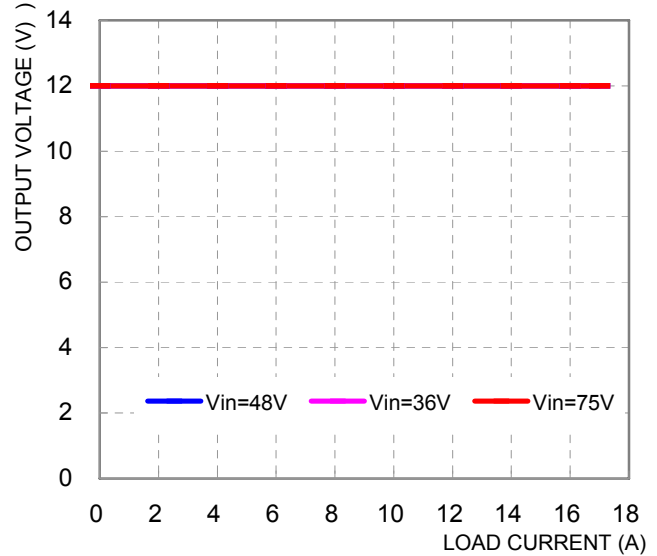
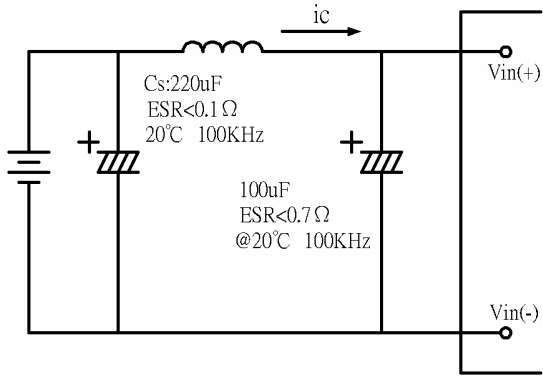

Figure 8: Output characteristics at room temperature

ELECTRICAL CHARACTERISTICS CURVES



22-Jun-05
16:00:07

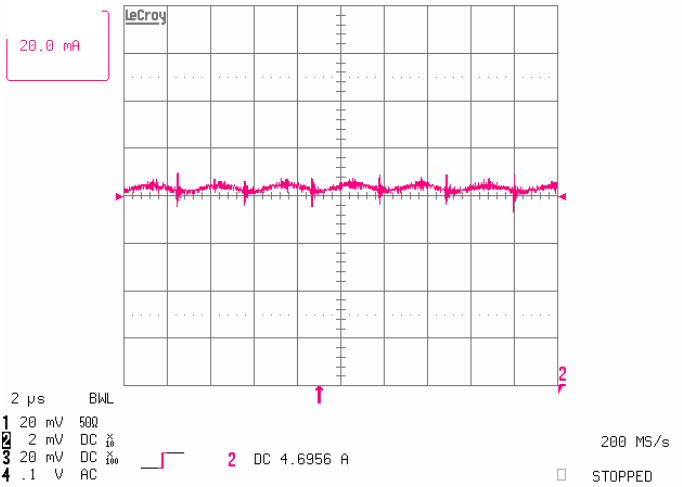

Figure 9: Test set-up diagram showing measurement points for Input Terminal Ripple Current and Input Reflected Ripple Current.

Note: Measured input reflected-ripple current with a simulated source Inductance (L_{TEST}) of $12 \mu H$. Capacitor C_s offset possible battery impedance. Measure current as shown above.

Figure 10: Input reflected ripple current, i_c through a $12 \mu H$ source inductor at nominal input voltage and rated load current (20 mA/div).

ELECTRICAL CHARACTERISTICS CURVES

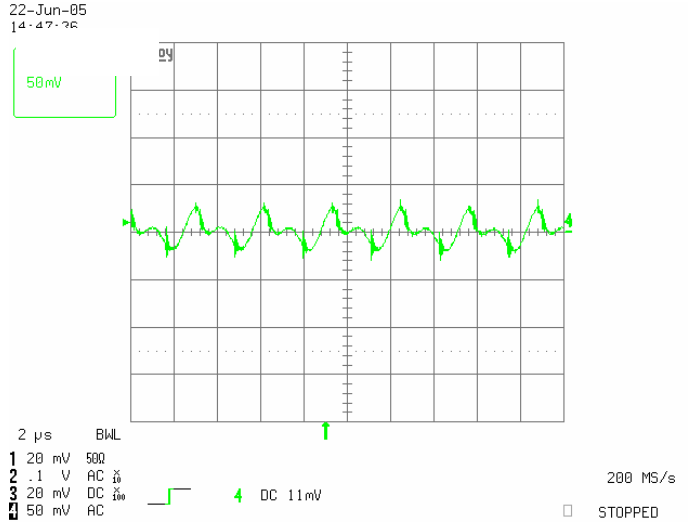
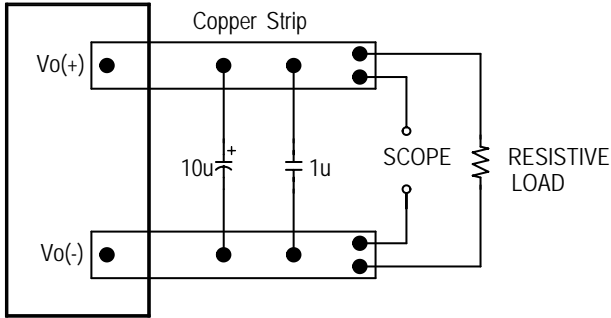

Figure 11: Output voltage noise and ripple measurement test setup

Figure 12: Output voltage ripple at 36V input voltage and rated load current (50 mV/div). Load capacitance: 1 μ F ceramic capacitor and 10 μ F tantalum capacitor. Bandwidth: 25 MHz. Scope measurements should be made using a BNC cable (length shorter than 20 inches). Position the load between 51 mm to 76 mm (2 inches to 3 inches) from the module.

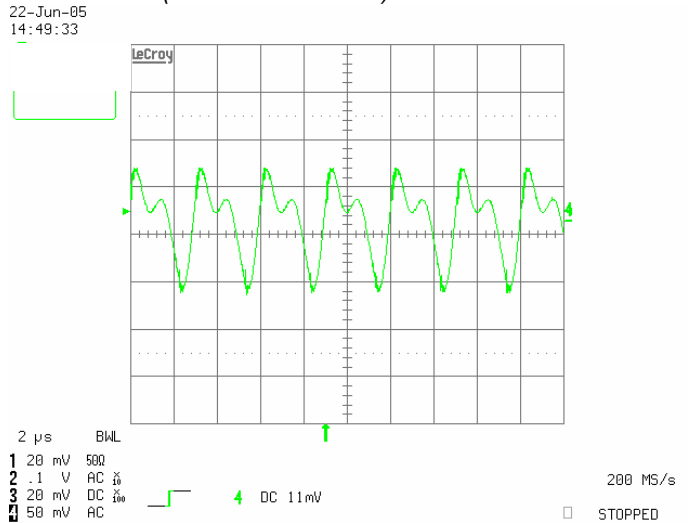
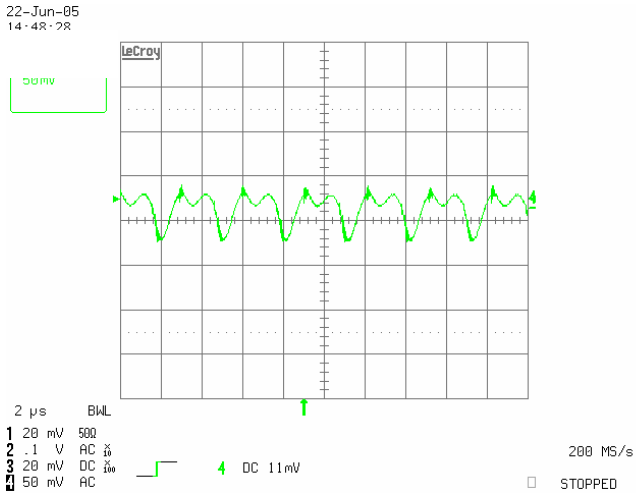

Figure 13: Output voltage ripple at 48V input voltage and rated load current (50 mV/div). Load capacitance: 1 μ F ceramic capacitor and 10 μ F tantalum capacitor. Bandwidth: 25 MHz. Scope measurements should be made using a BNC cable (length shorter than 20 inches). Position the load between 51 mm to 76 mm (2 inches to 3 inches) from the module.

Figure 14: Output voltage ripple at 75V input voltage and rated load current (50 mV/div). Load capacitance: 1 μ F ceramic capacitor and 10 μ F tantalum capacitor. Bandwidth: 25 MHz. Scope measurements should be made using a BNC cable (length shorter than 20 inches). Position the load between 51 mm to 76 mm (2 inches to 3 inches) from the module.



DESIGN CONSIDERATIONS

Input Source Impedance

The impedance of the input source connecting to the DC/DC power modules will interact with the modules and affect the stability. A low ac-impedance input source is recommended. If the source inductance is more than a few μH , we advise adding a 100 μF electrolytic capacitor (ESR < 0.7 Ω at 100 kHz) mounted close to the input of the module to improve the stability.

Layout and EMC Considerations

Delta's DC/DC power modules are designed to operate in a wide variety of systems and applications. For design assistance with EMC compliance and related PWB layout issues, please contact Delta's technical support team. An external input filter module is available for easier EMC compliance design. Application notes to assist designers in addressing these issues are pending to release.

Safety Considerations

The power module must be installed in compliance with the spacing and separation requirements of the end-user's safety agency standard, i.e., UL60950, CAN/CSA-C22.2 NO.60950-00 and EN60950:2000 and IEC60950-1999, if the system in which the power module is to be used must meet safety agency requirements.

When the input source is 60 Vdc or below, the power module meets SELV (safety extra-low voltage) requirements. If the input source is a hazardous voltage which is greater than 60 Vdc and less than or equal to 75 Vdc, for the module's output to meet SELV requirements, all of the following must be met:

- The input source must be insulated from any hazardous voltages, including the ac mains, with reinforced insulation.
- One V_i pin and one V_o pin are grounded, or all the input and output pins are kept floating.
- The input terminals of the module are not operator accessible.
- A SELV reliability test is conducted on the system where the module is used to ensure that under a single fault, hazardous voltage does not appear at the module's output.

Do not ground one of the input pins without grounding one of the output pins. This connection may allow a non-SELV voltage to appear between the output pin and ground.

The power module has extra-low voltage (ELV) outputs when all inputs are ELV.

This power module is not internally fused. To achieve optimum safety and system protection, an input line fuse is highly recommended. The safety agencies require a normal-blow fuse with 20A maximum rating to be installed in the ungrounded lead. A lower rated fuse can be used based on the maximum inrush transient energy and maximum input current.

Soldering and Cleaning Considerations

Post solder cleaning is usually the final board assembly process before the board or system undergoes electrical testing. Inadequate cleaning and/or drying may lower the reliability of a power module and severely affect the finished circuit board assembly test. Adequate cleaning and/or drying is especially important for un-encapsulated and/or open frame type power modules. For assistance on appropriate soldering and cleaning procedures, please contact Delta's technical support team.

FEATURES DESCRIPTIONS

Over-Current Protection

The modules include an internal output over-current protection circuit, which will endure current limiting for an unlimited duration during output overload. If the output current exceeds the OCP set point, the modules will automatically shut down and latch off.

Over-Voltage Protection

The modules include an internal output over-voltage protection circuit, which monitors the voltage on the output terminals. If this voltage exceeds the over-voltage set point, the module will shut down and latch off. Cycling the input power for one second can reset the over-voltage latch.

Over-Temperature Protection

The over-temperature protection consists of circuitry that provides protection from thermal damage. If the temperature exceeds the over-temperature threshold the module will shut down.

The module will try to restart after shutdown. If the over-temperature condition still exists during restart, the module will shut down again. This restart trial will continue until the temperature is within specification.

Remote On/Off

The remote on/off feature on the module can be either negative or positive logic. Negative logic turns the module on during a logic low and off during a logic high. Positive logic turns the modules on during a logic high and off during a logic low.

Remote on/off can be controlled by an external switch between the on/off terminal and the Vi(-) terminal. The switch can be an open collector or open drain.

For negative logic if the remote on/off feature is not used, please short the on/off pin to Vi(-). For positive logic if the remote on/off feature is not used, please leave the on/off pin floating.

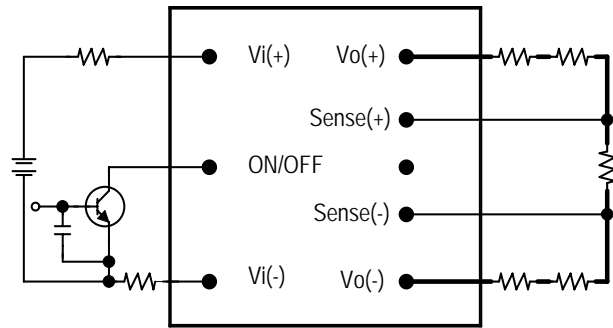

Figure 15: Remote on/off implementation

Remote Sense (Not applicable to Q48SP120017Exxx)

Remote sense compensates for voltage drops on the output by sensing the actual output voltage at the point of load. The voltage between the remote sense pins and the output terminals must not exceed the output voltage sense range given here:

$$[Vo(+) - Vo(-)] - [SENSE(+) - SENSE(-)] \leq 0.5V$$

This limit includes any increase in voltage due to remote sense compensation and output voltage set point adjustment (trim).

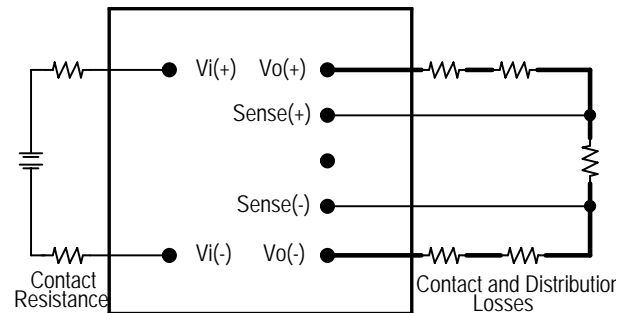

Figure 16: Effective circuit configuration for remote sense operation

If the remote sense feature is not used to regulate the output at the point of load, please connect SENSE(+) to Vo(+) and SENSE(-) to Vo(-) at the module.

The output voltage can be increased by both the remote sense and the trim; however, the maximum allowed increase is the larger of either the remote sense spec or the trim spec, not the sum of both.

When using remote sense and trim, the output voltage of the module is usually increased, which increases the power output of the module with the same output current.

Care should be taken to ensure that the maximum output power does not exceed the maximum rated power.

FEATURES DESCRIPTIONS (CON.)

Output Voltage Adjustment (TRIM) (Not applicable to Q48SP120017Exxx)

To increase or decrease the output voltage set point, connect an external resistor between the TRIM pin and either the SENSE(+) or SENSE(-). The TRIM pin should be left open if this feature is not used.

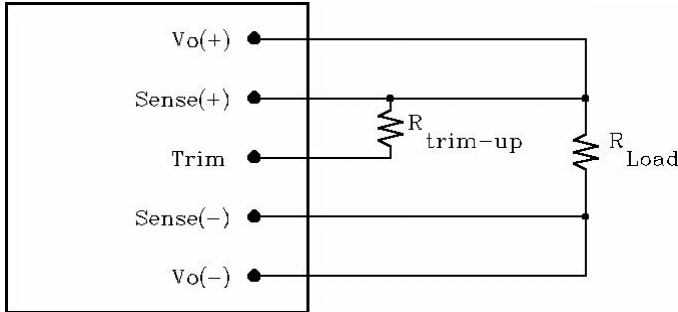

Figure 17: Circuit configuration for trim-up (increase output voltage)

If the external resistor is connected between the TRIM and SENSE (+) pins, the output voltage set point increases (Fig. 17). The external resistor value required to obtain a percentage of output voltage change $\Delta\%$ is defined as:

$$R_{trim_up} = \left(\frac{5.11 \times V_o(100 + \Delta)}{1.225\Delta} - \frac{511}{\Delta} - 10.22 \right) (K\Omega)$$

$$\Delta = \left(\frac{|V_{nom} - V_{adj}|}{V_{nom}} \right) \times 100$$

V_o = Nominal voltage

Ex. When trim up to 13.2V from 12V

$$R_{trim_up} = \frac{5.11 \times 12(100 + 10)}{1.225 \times 10} - \frac{511}{10} - 10.22$$

$$\Rightarrow = 489.3K\Omega$$

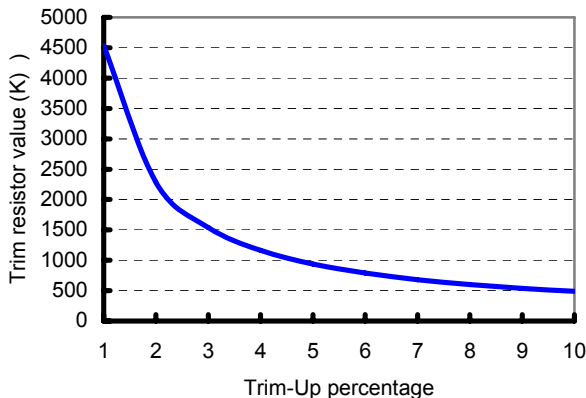

Figure 18: Trim UP resistor selection

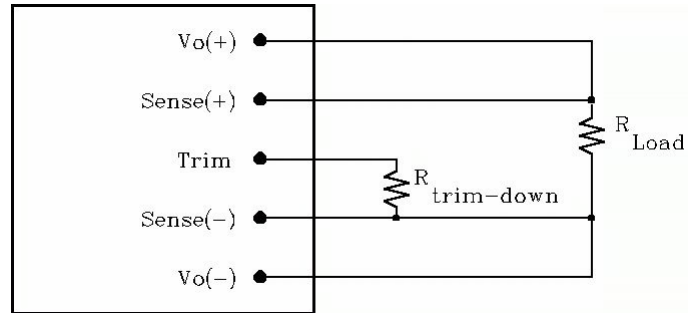

Figure 19: Circuit configuration for trim-down (decrease output voltage)

If the external resistor is connected between the TRIM and SENSE (-) the output voltage set point decreases (Fig. 19). The external resistor value required to obtain a percentage output voltage change $\Delta\%$ is defined as:

$$R_{trim_down}(\Delta) = \left(\frac{511}{\Delta} - 10.22 \right) k\Omega$$

Ex. When trim down to 9.6V from 12V

$$R_{trim_down} = \frac{511}{20} - 10.22 K\Omega = 15.33 K\Omega$$

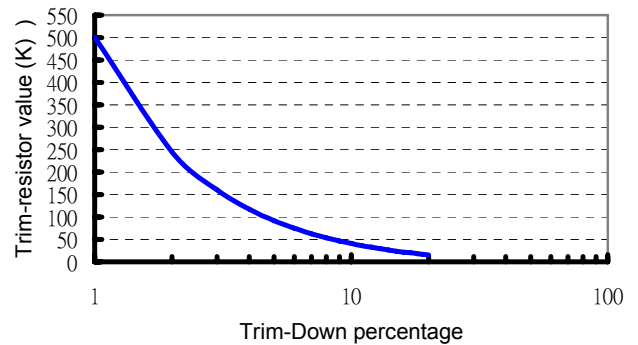

Figure 20: Trim DOWN resistor selection

The output voltage can be increased by both the remote sense and the trim, however the maximum allowed increase is the larger of either the remote sense spec or the trim spec, not the sum of both.

When using remote sense and trim, the output voltage of the module is usually increased, which increases the power output of the module with the same output current.

Care should be taken to ensure that the maximum output power of the module remains at or below the maximum rated power.



THERMAL CONSIDERATIONS

Thermal management is an important part of the system design. To ensure proper, reliable operation, sufficient cooling of the power module is needed over the entire temperature range of the module. Convection cooling is usually the dominant mode of heat transfer.

Hence, the choice of equipment to characterize the thermal performance of the power module is a wind tunnel.

Thermal Testing Setup

Delta's DC/DC power modules are characterized in heated vertical wind tunnels that simulate the thermal environments encountered in most electronics equipment. This type of equipment commonly uses vertically mounted circuit cards in cabinet racks in which the power modules are mounted.

The following figure shows the wind tunnel characterization setup. The power module is mounted on a test PWB and is vertically positioned within the wind tunnel. The space between the neighboring PWB and the top of the power module is constantly kept at 6.35mm (0.25").

Thermal Derating

Heat can be removed by increasing airflow over the module. The module's maximum hot spot temperature is pending to release and the measured location is illustrated in Figure 22. To enhance system reliability, the power module should always be operated below the maximum operating temperature. If the temperature exceeds the maximum module temperature, reliability of the unit may be affected.

THERMAL CURVES

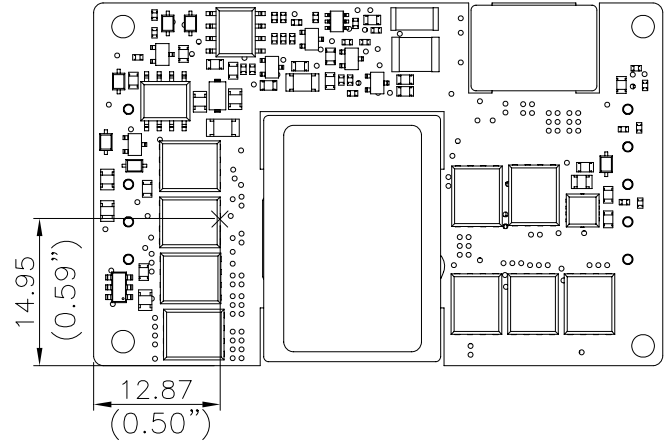

Figure 22: Temperature measurement location
The allowed maximum hot spot temperature is defined at 120°C

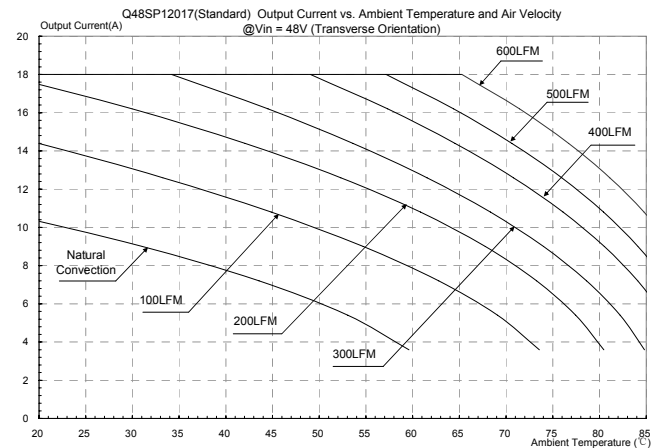
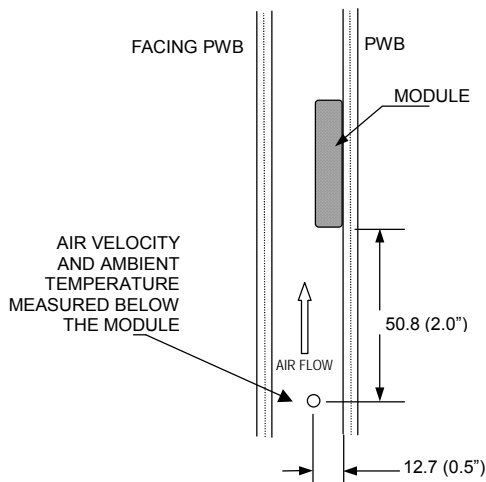

Figure 23: Output current vs. ambient temperature and air velocity @ $V_{in}=48V$ (Transverse orientation)



Note: Wind Tunnel Test Setup Figure Dimensions are in millimeters and (Inches)

Figure 21: Wind tunnel test setup

MECHANICAL DRAWING (WITHOUT HEATSPERADER)

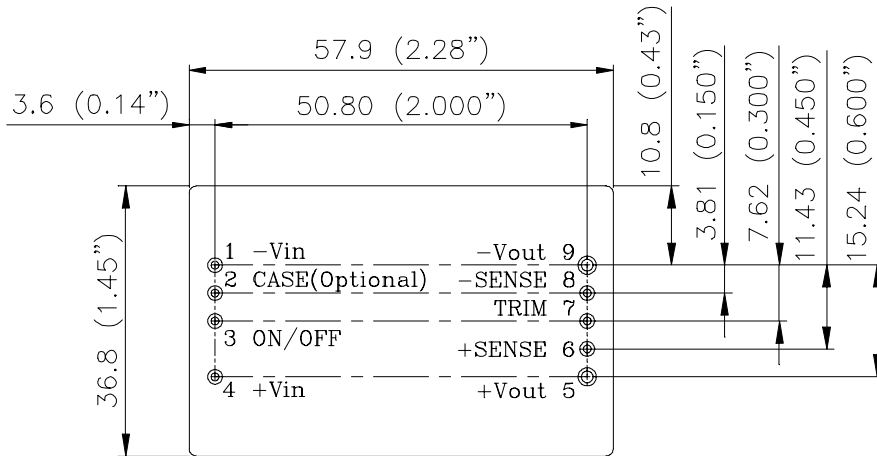

BOTTOM VIEW

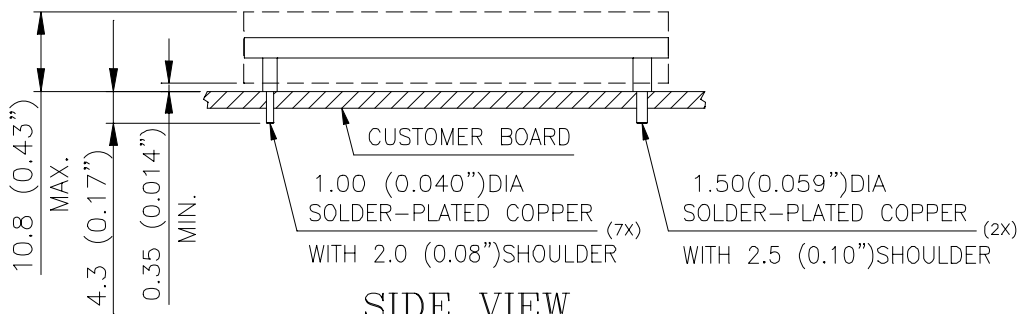

SIDE VIEW

NOTES:

DIMENSIONS ARE IN MILLIMETERS AND (INCHES)

TOLERANCES: X.Xmm±0.5mm(X.XX in.±0.02 in.)

X.XXmm±0.25mm(X.XXX in.±0.010 in.)

Pin No.	Name	Function
1	-Vin	Negative input voltage
2	CASE	Case ground pin
3	ON/OFF	Remote ON/OFF
4	+Vin	Positive input voltage
5	+Vout	Positive output voltage
6	+SENSE	Positive remote sense
7	TRIM	Output voltage trim
8	-SENSE	Negative remote sense
9	-Vout	Negative output voltage

Notes:

- Pins 1-4, 6-8 are 1.00mm (0.040") diameter
- Pins 5 and 9 are 1.50mm (0.060") diameter
- All pins are copper with Tin plating

Mechanical Drawing (FOR Q48SP12017Exxx)

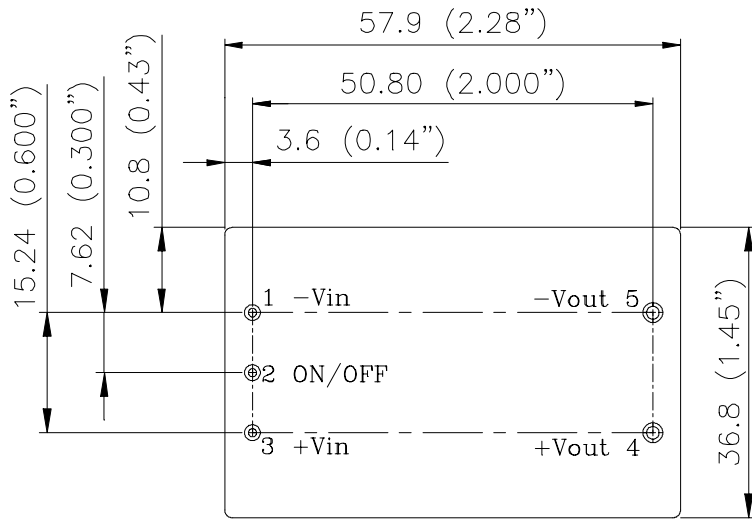

BOTTOM VIEW

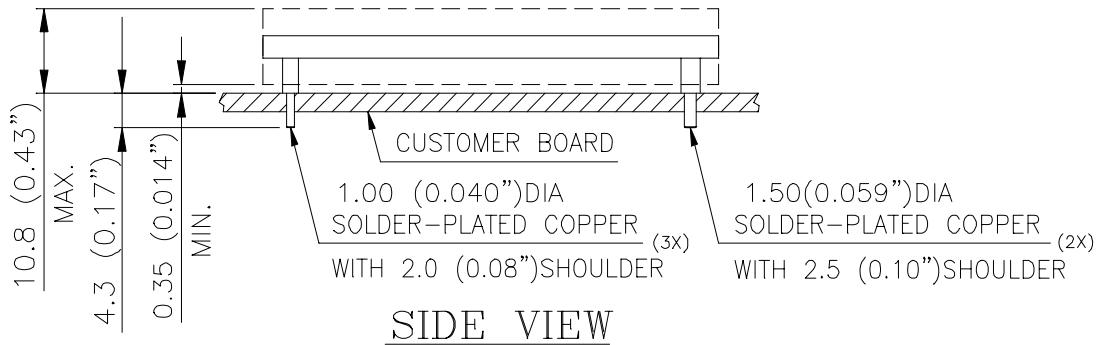

SIDE VIEW

NOTES:

DIMENSIONS ARE IN MILLIMETERS AND (INCHES)

TOLERANCES: X.Xmm±0.5mm(X.XX in.±0.02 in.)

X.XXmm±0.25mm(X.XXX in.±0.010 in.)

MECHANICAL DRAWING (WITH HEATSPREADER)

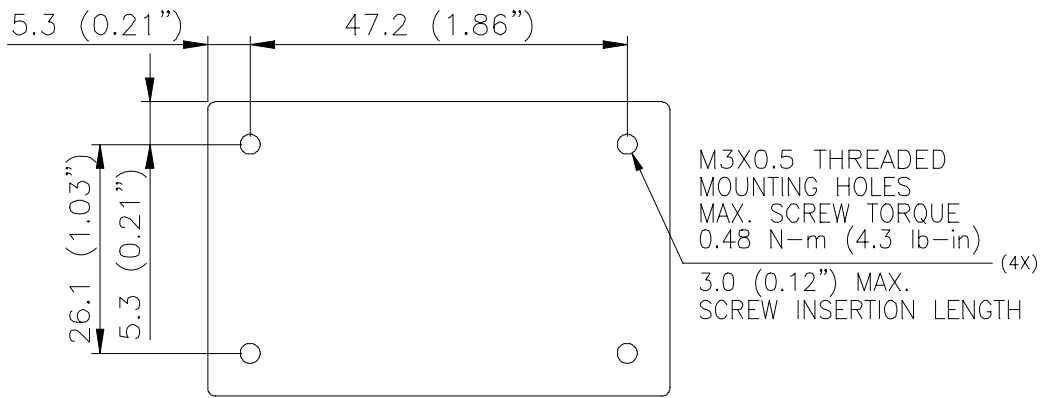

TOP VIEW

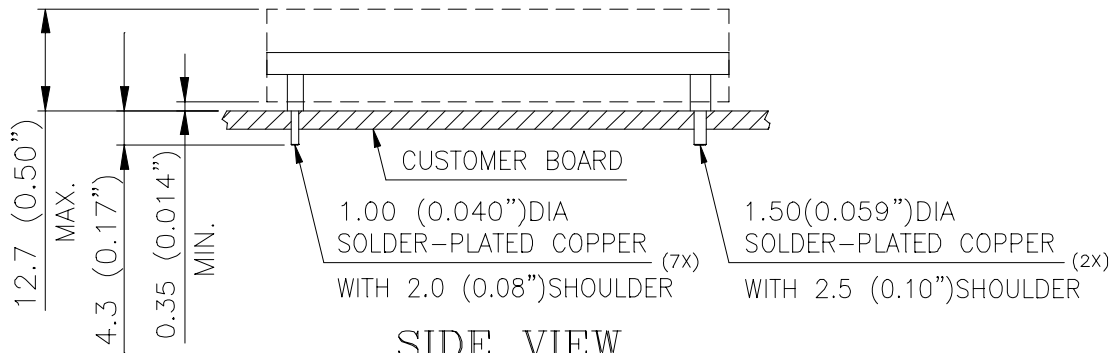

SIDE VIEW

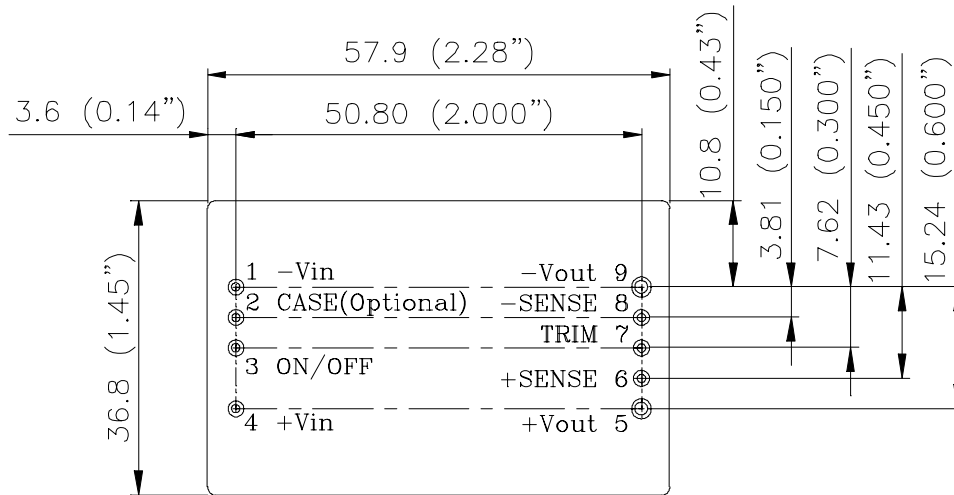

BOTTOM VIEW

NOTES:

DIMENSIONS ARE IN MILLIMETERS AND (INCHES)

TOLERANCES: X.Xmm±0.5mm(X.XX in.±0.02 in.)

X.XXmm±0.25mm(X.XXX in.±0.010 in.)

PART NUMBERING SYSTEM

Q	48	S	P	120	17	N	R	F	A
Form Factor	Input Voltage	Number of Outputs	Product Series	Output Voltage	Output Current	ON/OFF Logic	Pin Length		Option Code
Q - Quarter Brick	48 - 36~75V	S - Single	P - 200W series	120 - 12V	18A	N - Negative P - Positive E - Negative and no trim, no sense pins	R - 0.170" N - 0.145" K - 0.110"	F- RoHS 6/6 (Lead Free) Space - RoHs 5/6	A - Std. Function with case pin B - w/o case pin H - With heatspreader and case pin

MODEL LIST

MODEL NAME	INPUT		OUTPUT		EFF @ 100% LOAD
Q48SP12017NRFA	36V~75V	7A	12V	18A	92.5%
Q48SP12017NRFH	36V~75V	7A	12V	18A	92.5%
Q48SP12017ERFB	36V~75V	7A	12V	18A	92.5%
Q48SP12017ERFH	36V~75V	7A	12V	18A	92.5%

CONTACT: www.delta.com.tw/dcdc

USA:

Telephone:
East Coast: (888) 335 8201
West Coast: (888) 335 8208
Fax: (978) 656 3964
Email: DCDC@delta-corp.com

Europe:

Telephone: +41 31 998 53 11
Fax: +41 31 998 53 53
Email: DCDC@delta-es.tw

Asia & the rest of world:

Telephone: +886 3 4526107 x6220
Fax: +886 3 4513485
Email: DCDC@delta.com.tw

WARRANTY

Delta offers a two (2) year limited warranty. Complete warranty information is listed on our web site or is available upon request from Delta.

Information furnished by Delta is believed to be accurate and reliable. However, no responsibility is assumed by Delta for its use, nor for any infringements of patents or other rights of third parties, which may result from its use. No license is granted by implication or otherwise under any patent or patent rights of Delta. Delta reserves the right to revise these specifications at any time, without notice.