

INSIGNIA™

# Corner TV Stand

NS-WG1542



SAFETY INFORMATION AND SPECIFICATIONS....	2
PACKAGE CONTENTS: HARDWARE.....	3
PACKAGE CONTENTS: PARTS.....	4
ASSEMBLY INSTRUCTIONS.....	5
CARE AND MAINTENANCE.....	9

Before using your new product, please read these instructions to prevent any damage.

# SAFETY INFORMATION AND SPECIFICATIONS



**CAUTION:** The top surface of this stand is designed for use with a product weighing no more than 70 lbs. (31 kg) and having a width that permits it to sit evenly on the stand with no more than a one-inch overhang on each side of the shelf. Use with products that weigh more than the maximum weight allowed, or with dimensions that extend beyond the maximum width may result in instability, which may result in injury.



**CAUTION:** This product contains small items that could be a choking hazard if swallowed. Keep these items away from young children!

Model #: NS-WG1542

**Maximum overall weight:** 145 lbs. (65.8 kg)  
**Maximum top shelf weight:** 70 lbs. (31 kg)  
**Maximum middle and bottom shelf weight:** 25 lbs. (11.3 kg)  
**Maximum screen size:** 42" diagonal  
**Overall dimensions (H x W x D):**  
 22 x 44 x 19.65 in. (55.9 x 111.7 x 49.9 cm)

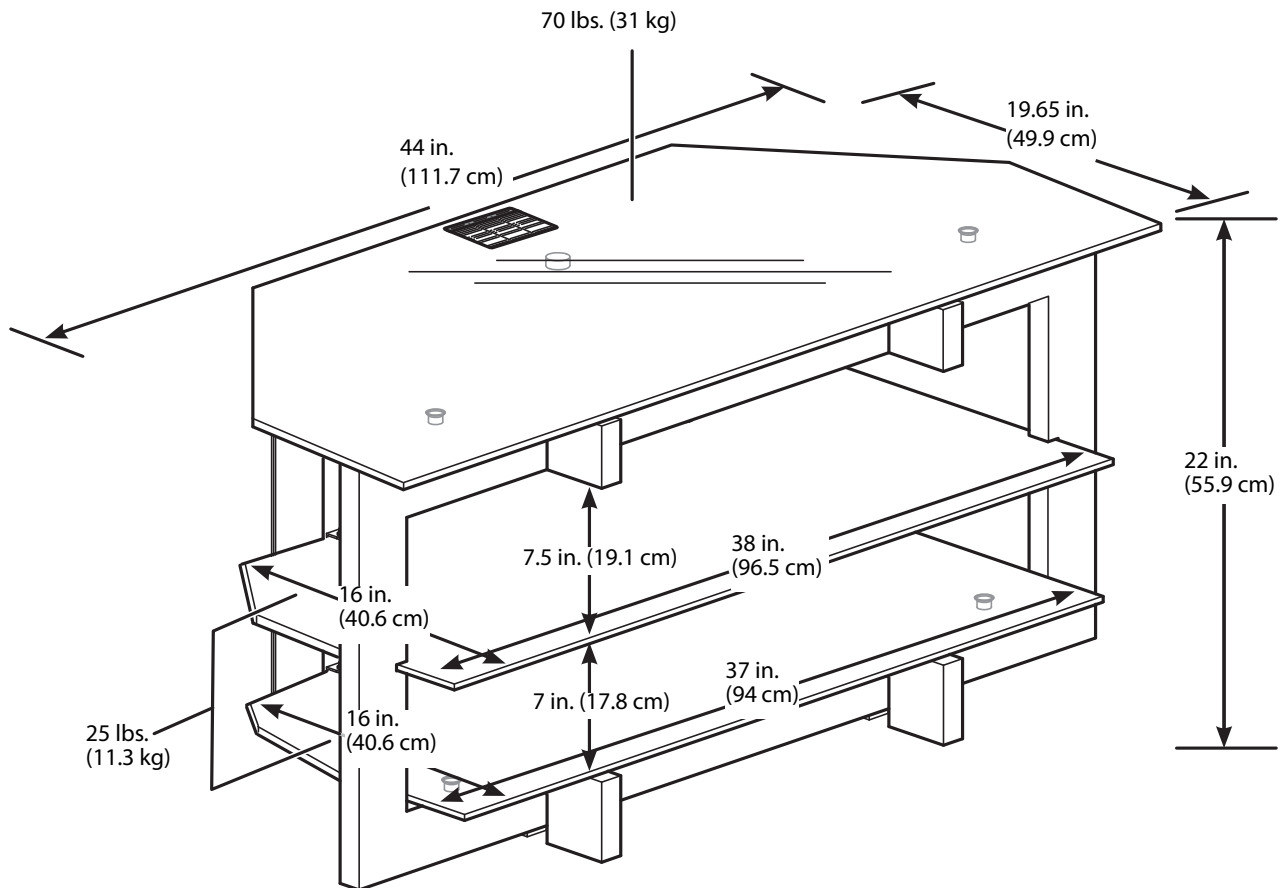

**Caution:** Do not use power tools to assemble your stand.

**Note:** Make sure that you have all the hardware necessary to assemble your new TV stand.

**Tools needed:**





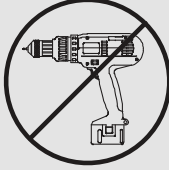



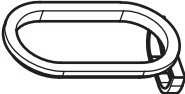

Phillips screwdriver

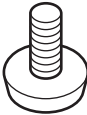

## PACKAGE CONTENTS: HARDWARE

**Note:** The table below shows the required hardware. You may receive extra hardware.

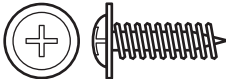
Label	Hardware	Qty.
H	 Cable collar	1
I	 Glass spacer	4
J	 Floor leveler	4
K	 Allen screw - 5 mm x 50 mm	4
L	 Allen bolt - 6 mm x 50 mm	2

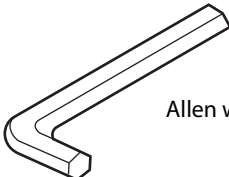
Label	Hardware	Qty.
M	 Allen bolt - 6 mm x 25 mm	1
N	 Phillips screw - 4 mm x 15 mm	6
O	 Shelf bolt	4
P	 Allen wrench	1

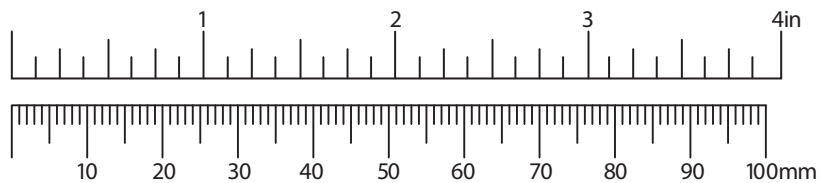

## PACKAGE CONTENTS: PARTS

Make sure that you have all the parts necessary to assemble your new TV stand. While not all parts are labeled, some of the parts will have a label or an inked letter on the edge to help distinguish similar parts from each other. Use this part identification to help identify similar parts.

Carefully unpack and identify each component before attempting to assemble. Refer to the parts list.

Please take care when assembling the unit and always place the parts on a clean, soft surface.

If you require any assistance with assembly, parts, or information on other products, please visit our website: [www.insigniaproducts.com](http://www.insigniaproducts.com) or call us.

Wood in its natural state comes with variations in color and grain, so not all pieces of wood will match in color and grain. These variations are compounded when you try to match a number of pieces of wood, such as you would have when making a piece of furniture. This is normal.

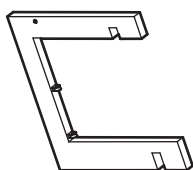

A. Leg (2)

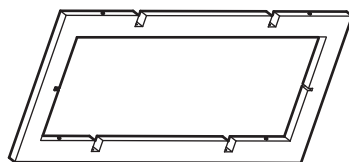

B. Frame (1)



C. Support bar (1)

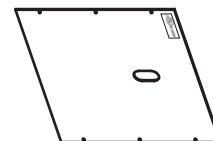

D. Rear panel (1)

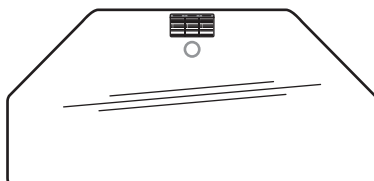

E. Top shelf (1)

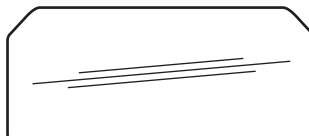

F. Middle shelf (1)

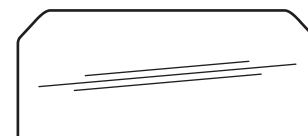

G. Bottom shelf (1)

# ASSEMBLY INSTRUCTIONS

## Step 1: Preparing the legs and frame.

**Caution:** Do not fully tighten allen bolts (L) until Step 2.

- 1 Screw four floor levelers (J) into the holes in the legs (A).
- 2 Connect the slots on the legs (A) to the slots on the frame (B), and attach using four allen screws (K) with the allen wrench (P).

**Tips:**

The back side of frame (B) is labeled "Back."

The top of the legs (A) and the top of the frame (B) should be flush when the parts are connected.

- 3 Attach the support bar (C) to the legs using two allen bolts (L) with the allen wrench (P).

**Tip:** The hole in the support bar (C) should face up (see the arrow).

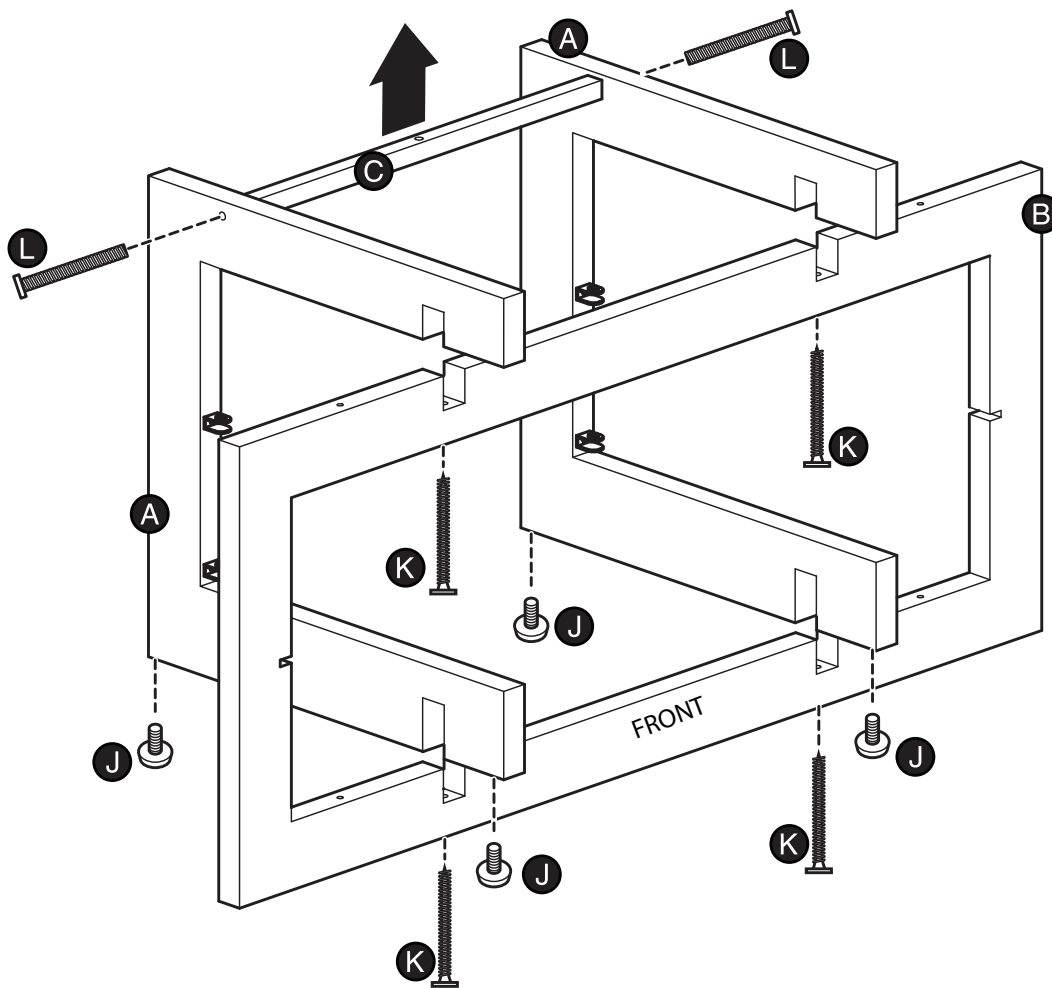

### You'll need:

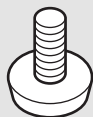

4 - Floor levelers (J)



4 - Allen screws (K)



2 - Allen bolts (L)

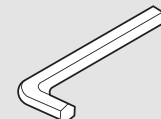

1 - Allen wrench (P)

## Step 2: Attaching the back panel and the top shelf



**CAUTION:** Tempered safety glass is used. It is stronger than normal glass, and it will not break into long, sharp, knife-like shards. However, safety glass can break. When safety glass breaks, it instantly fractures into small, bead-like pieces. These small pieces may have sharp edges.

For your safety, follow these precautions when you assemble your product:

Wear safety glasses or other eye protection.

Do not try to drill into or cut safety glass. It will instantly break into small pieces.

Do not force the glass into position.

If the glass breaks, be careful when you pick up the pieces. They may have sharp edges.

- 1 Insert the cable collar (H) into the hole in the rear panel (D).
- 2 Attach the rear panel (D) to the back of the legs with the cable clip of the cable collar facing out using six phillips screws (N).
- 3 Insert four glass spacers (I) into the holes in the frame.
- 4 Carefully place the top shelf (E) onto the top two glass spacers and align the metal tab with the hole in the support bar (C).
- 5 Screw one allen bolt (M) through the hole in the support bar (C) and into metal tab on the top shelf (E).
- 6 Tighten the allen bolts (L) from the previous step.

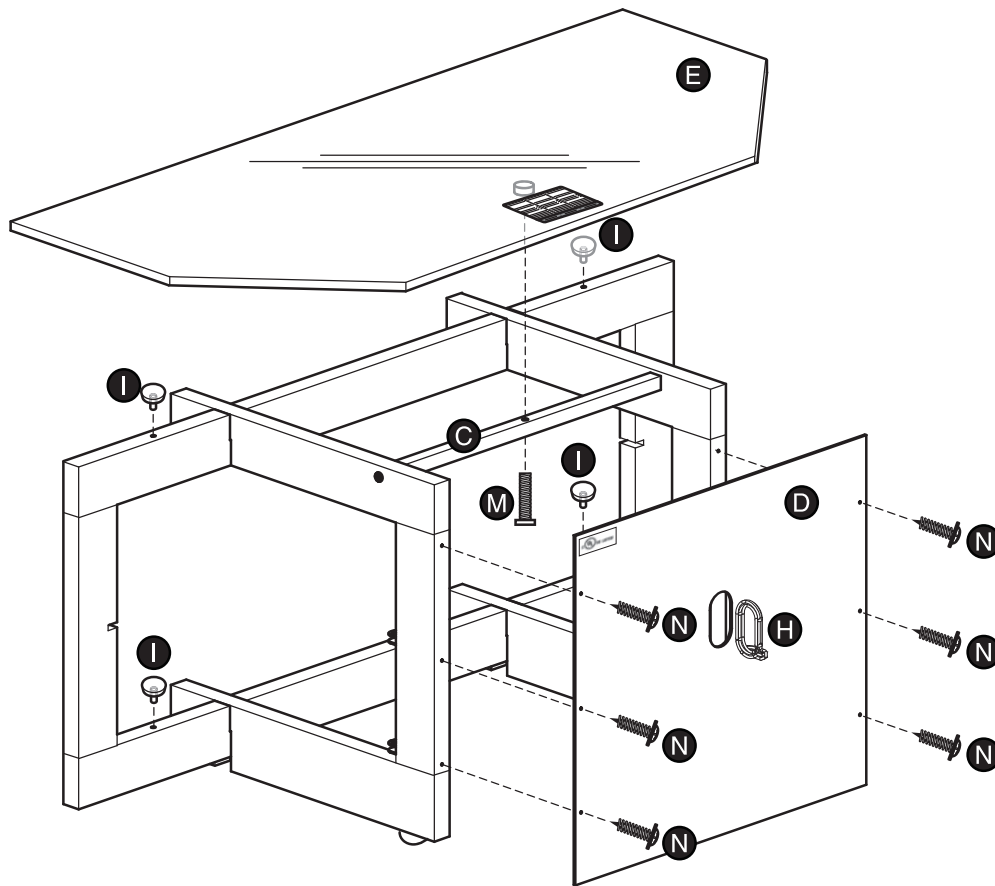

### You'll need:

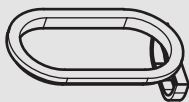

1 - Cable collar (H)



6 - Phillips screws (N)



1 - Allen bolt (M)



4 - Glass spacers (I)



1 - Allen wrench (P)



Phillips screwdriver

**Step 3: Attaching the middle and bottom shelves.**

- 1 Carefully place the smaller bottom shelf (G) onto the glass spacers in the frame and into the shelf supports.
- 2 Screw two shelf bolts (O) into the holes in the bottom shelf supports - do not overtighten.
- 3 Carefully place the middle shelf (F) through the slots in the frame and into the shelf supports.
- 4 Screw two shelf bolts (O) into the holes in the middle shelf supports - do not overtighten.

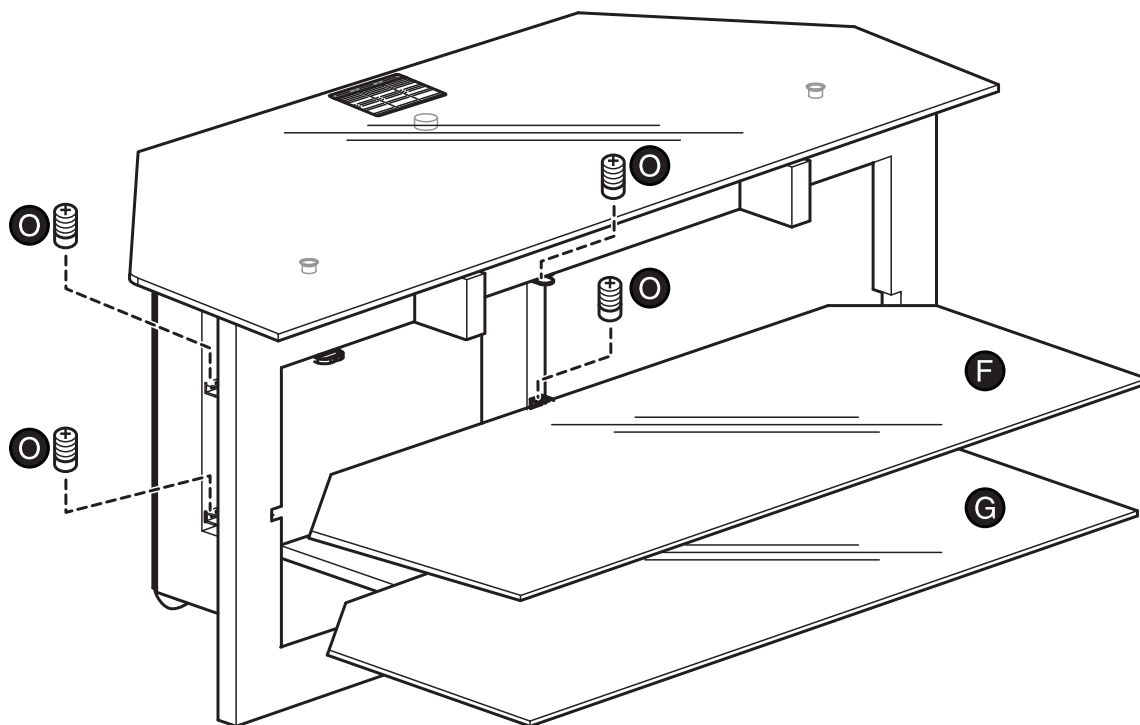
**You'll need:**

Phillips screwdriver



4 - Shelf bolts (O)

#### Step 4: Adjusting the floor levelers.

- Make sure all floor levelers are adjusted properly and have firm contact with the floor.  
**DO NOT** exceed the weight limits shown.

**CAUTION!** When moving the stand, do not lift the glass top. Use two adults and lift from the frame or leg assembly. Please use care and good judgement when placing objects on top and middle shelves.

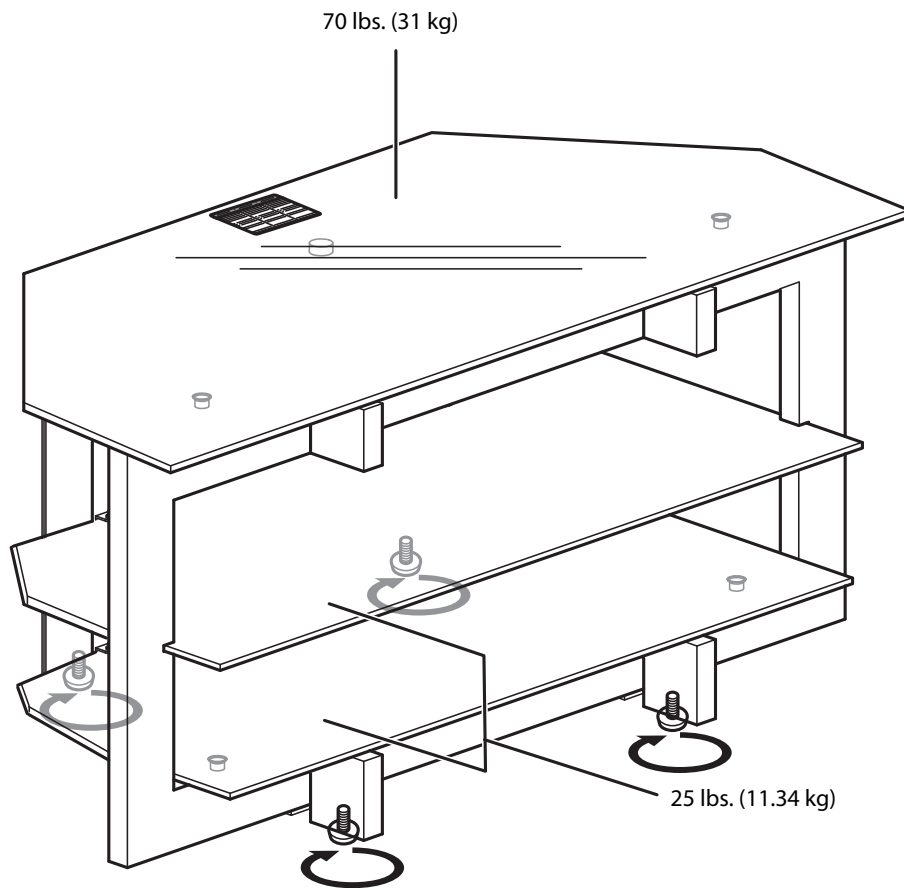



# CARE AND MAINTENANCE

## Wood/Laminate

- Use your favorite type of furniture polish.
- Do not spray polish directly onto the stand. Spray onto a soft cloth then wipe the stand.
- Always test any polish in a discrete location first, such as the back of the stand, to make sure that there is no adverse reaction.
- Dust frequently with a soft cloth.
- Never slide objects across surfaces. Lift objects from the top surface rather than dragging them across the finish when moving them.
- Do not expose your stand to direct sunlight, drying heat sources, or dampness.

## Glass

- Use a commercial liquid glass cleaner and a soft cloth.
- Do not use harsh powders or any other abrasive substances as they will scratch the glass.
- Clean spills immediately with a soft, damp cloth.
- Protect surfaces by using felt, leather, or cork under accessories.
- Use a protective pad when using your stand as a writing surface (especially when using a ballpoint pen).
- Dust frequently with a soft cloth.

## WARNING

Please use your stand correctly and safely. Improper use can cause safety hazards or damage to your furniture or household items. Carefully read the following chart.

Look out for:	What can happen:	How to avoid the problem:
<ul style="list-style-type: none"> <li>• Children climbing on the stand.</li> <li>• A child may try to reach a toy or other object by climbing on the stand.</li> <li>• Children will play and be active near the TV.</li> </ul>	<ul style="list-style-type: none"> <li>• Risk of injury or death.</li> <li>• A child climbing on the stand can make it top-heavy and cause it to tip over.</li> <li>• A child playing with a TV can cause it to tip over.</li> </ul>	<ul style="list-style-type: none"> <li>• Never allow children to climb on or play with the stand.</li> <li>• Do not place toys or food on the top shelves. Children may try to climb to reach them out of curiosity.</li> </ul>
<ul style="list-style-type: none"> <li>• Improper use of the stand to support TVs.</li> <li>• The stand is designed for use with TVs will specify the maximum weight rating and recommended size of the TVs it will safely support.</li> </ul>	<ul style="list-style-type: none"> <li>• Risk of injury or death.</li> <li>• TVs can be very heavy. Note, older CRT TVs tend to be unbalanced and prone to tipping forward.</li> </ul>	<ul style="list-style-type: none"> <li>• A TV must only be set on furniture specifically designed to support a television.</li> <li>• Never use a TV that exceeds the weight ratings or size guidelines specified for the stand.</li> </ul>
<ul style="list-style-type: none"> <li>• Overloaded shelves.</li> </ul>	<ul style="list-style-type: none"> <li>• Risk of injury.</li> <li>• Top-heavy furniture can tip over.</li> <li>• Overloaded shelves can break.</li> </ul>	<ul style="list-style-type: none"> <li>• Never exceed the weight limits. The bottom shelves can only support 25 lbs. while the top can support 70 lbs.</li> <li>• Work from the bottom to the top when loading shelves.</li> </ul>
<ul style="list-style-type: none"> <li>• Improperly moving the stand.</li> </ul>	<ul style="list-style-type: none"> <li>• The stand can tip over or break if improperly moved.</li> <li>• Risk of injury.</li> </ul>	<ul style="list-style-type: none"> <li>• Unload shelves from the top to the bottom before moving the stand.</li> <li>• Do not push the stand, especially on a carpeted floor. Have a friend help you lift the item and set it in place.</li> <li>• Do not lift the stand using the top shelf. Lift from the frame or leg assembly.</li> <li>• Remove the TV before moving the TV stand.</li> </ul>



# ONE-YEAR LIMITED WARRANTY - INSIGNIA

## Definitions:

The Distributor\* of Insignia branded products warrants to you, the original purchaser of this new Insignia-branded product ("Product"), that the Product shall be free of defects in the original manufacturer of the material or workmanship for a period of one (1) year from the date of your purchase of the Product ("Warranty Period").

For this warranty to apply, your Product must be purchased in the United States or Canada from a Best Buy branded or Future Shop branded retail store or online at [www.bestbuy.com](http://www.bestbuy.com), [www.bestbuy.ca](http://www.bestbuy.ca), or [www.futureshop.ca](http://www.futureshop.ca) and is packaged with this warranty statement.

## How long does the coverage last?

The Warranty Period lasts for 1 year (365 days) from the date you purchased the Product. Your purchase date is printed on the receipt you received with the Product.

## What does this warranty cover?

During the Warranty Period, if the original manufacture of the material or workmanship of the Product is determined to be defective by an authorized Insignia repair center or store personnel, Insignia will (at its sole option): (1) repair the Product with new or rebuilt parts; or (2) replace the Product at no charge with new or rebuilt comparable products or parts. Products and parts replaced under this warranty become the property of Insignia and are not returned to you. If service of Products or parts are required after the Warranty Period expires, you must pay all labor and parts charges. This warranty lasts as long as you own your Insignia Product during the Warranty Period. Warranty coverage terminates if you sell or otherwise transfer the Product.

## How to obtain warranty service?

If you purchased the Product at a Best Buy or Future Shop retail store location, please take your original receipt and the Product to any Best Buy or Future Shop store. Make sure that you place the Product in its original packaging or packaging that provides the same amount of protection as the original packaging. If you purchased the Product from a Best Buy or Future Shop online web site ([www.bestbuy.com](http://www.bestbuy.com), [www.bestbuy.ca](http://www.bestbuy.ca), or [www.futureshop.ca](http://www.futureshop.ca)), mail your original receipt and the Product to the address listed on the web site. Make sure that you put the Product in its original packaging or packaging that provides the same amount of protection as the original packaging.

To obtain warranty service, in the United States call 1-888-BESTBUY, Canada call 1-866-BESTBUY for Future Shop call 1-800-663-2275. Call agents may diagnose and correct the issue over the phone.

## Where is the warranty valid?

This warranty is valid only in the United States and Canada at Best Buy or Future Shop branded retail stores or websites to the original purchaser of the product in the county where the original purchase was made.

## What does the warranty not cover?

This warranty does not cover:

- Customer instruction/education
- Installation
- Set up adjustments
- Cosmetic damage
- Damage due to weather, lightning, and other acts of God, such as power surges
- Accidental damage
- Misuse
- Abuse
- Negligence
- Commercial purposes/use, including but not limited to use in a place of business or in communal areas of a multiple dwelling condominium or apartment complex, or otherwise used in a place of other than a private home.

- Modification of any part of the Product, including the antenna
- Display panel damaged by static (non-moving) images applied for lengthy periods (burn-in).
- Damage due to incorrect operation or maintenance
- Connection to an incorrect voltage or power supply
- Attempted repair by any person not authorized by Insignia to service the Product
- Products sold "as is" or "with all faults"
- Consumables, including but not limited to batteries (i.e. AA, AAA, C etc.)
- Products where the factory applied serial number has been altered or removed
- Loss or Theft of this product or any part of the product
- Display panels containing up to three (3) pixel failures (dots that are dark or incorrectly illuminated) grouped in an area smaller than one tenth (1/10) of the display size or up to five (5) pixel failures throughout the display. (Pixel based displays may contain a limited number of pixels that may not function normally.)
- Failures or Damage caused by any contact including but not limited to liquids, gels or pastes.

REPAIR REPLACEMENT AS PROVIDED UNDER THIS WARRANTY IS YOUR EXCLUSIVE REMEDY FOR BREACH OF WARRANTY. INSIGNIA SHALL NOT BE LIABLE FOR ANY INCIDENTAL OR CONSEQUENTIAL DAMAGES FOR THE BREACH OF ANY EXPRESS OR IMPLIED WARRANTY ON THIS PRODUCT, INCLUDING, BUT NOT LIMITED TO, LOST DATA, LOSS OF USE OF YOUR PRODUCT, LOST BUSINESS OR LOST PROFITS. INSIGNIA PRODUCTS MAKES NO OTHER EXPRESS WARRANTIES WITH RESPECT TO THE PRODUCT, ALL EXPRESS AND IMPLIED WARRANTIES FOR THE PRODUCT, INCLUDING, BUT NOT LIMITED TO, ANY IMPLIED WARRANTIES OF AND CONDITIONS OF MERCHANTABILITY AND FITNESS FOR A PARTICULAR PURPOSE, ARE LIMITED IN DURATION TO THE WARRANTY PERIOD SET FORTH ABOVE AND NO WARRANTIES, WHETHER EXPRESS OR IMPLIED, WILL APPLY AFTER THE WARRANTY PERIOD. SOME STATES, PROVINCES AND JURISDICTIONS DO NOT ALLOW LIMITATIONS ON HOW LONG AN IMPLIED WARRANTY LASTS, SO THE ABOVE LIMITATION MAY NOT APPLY TO YOU. THIS WARRANTY GIVES YOU SPECIFIC LEGAL RIGHTS, AND YOU MAY ALSO HAVE OTHER RIGHTS, WHICH VARY FROM STATE TO STATE OR PROVINCE TO PROVINCE.

Contact Insignia:

For customer service please call 1-877-467-4289

[www.insigniaproducts.com](http://www.insigniaproducts.com)

INSIGNIA is a trademark of Best Buy and its affiliated companies.

Registered in some countries.

Distributed by Best Buy Purchasing, LLC

7601 Penn Ave South, Richfield, MN 55423 U.S.A.

©2014 Best Buy. All rights reserved.

Made in Taiwan

# INSIGNIA™

## **Certificate of Conformity**

1. This certificate applies to the Insignia product identified by this instruction booklet.
2. This certificate applies to the compliance of this product with the CPSC Ban on Lead-Containing Paint (16 CFR 1303).
3. This product was manufactured for:  
Insignia
4. Date of Manufacture: \_\_\_\_\_

Lot number: 417095

1-877-467-4289 (U.S. and Canada) or 01-800-926-3000 (Mexico)  
[www.insigniaproducts.com](http://www.insigniaproducts.com)

INSIGNIA is a trademark of Best Buy and its affiliated companies.  
Registered in some countries.  
Distributed by Best Buy Purchasing, LLC  
7601 Penn Ave South, Richfield, MN 55423 U.S.A.  
©2014 Best Buy. All rights reserved.  
Made in Taiwan

V2 ENGLISH  
14-0295