

WEIDER® PRO 4100

Model No. 831.159823

Serial No. _____

Write the serial number in the space above for reference.

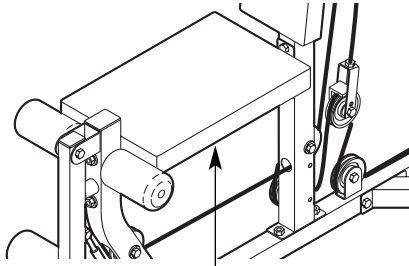

Serial Number Decal (under seat)

USER'S MANUAL

EXERCISE
EQUIPMENT

QUESTIONS

HELPLINE!

1-800-736-6879

SEARS, ROEBUCK AND CO.
HOFFMAN ESTATES, IL 60179

⚠ CAUTION

Read all precautions and instructions in this manual before using this equipment. Save this manual for future reference.

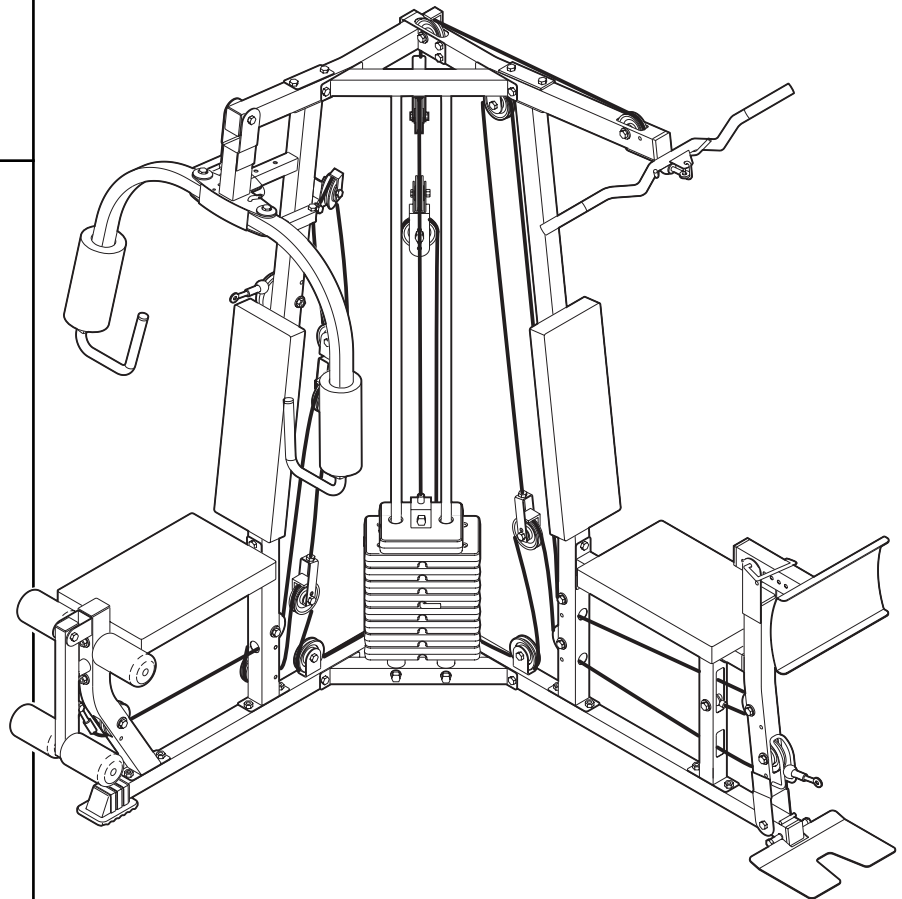

Visit our website at

www.weiderfitness.com

*new products, prizes,
fitness tips, and much more!*

TABLE OF CONTENTS

IMPORTANT PRECAUTIONS	3
BEFORE YOU BEGIN	4
ASSEMBLY	5
ADJUSTMENTS	21
WEIGHT RESISTANCE CHART	23
CABLE DIAGRAM	24
EXERCISE GUIDELINES	26
ORDERING REPLACEMENT PARTS	Back Cover
FULL 90 DAY WARRANTY	Back Cover

Note: A PART IDENTIFICATION CHART and a PART LIST/EXPLODED DRAWING are attached in the center of this manual. Remove the PART IDENTIFICATION CHART and the PART LIST/EXPLODED DRAWING before beginning assembly.

IMPORTANT PRECAUTIONS

⚠ WARNING: To reduce the risk of serious injury, read the following important precautions before using the weight system.

1. Read all instructions in this manual and in the accompanying literature before using the weight system. Use the weight system only as described in this manual.
2. It is the responsibility of the owner to ensure that all users of the weight system are adequately informed of all precautions.
3. The weight system is intended for home use only. Do not use the weight system in a commercial, rental, or institutional setting.
4. Use the weight system only on a level surface. Cover the floor or carpet beneath the weight system to protect the floor.
5. Make sure all parts are properly tightened each time the weight system is used. Replace any worn parts immediately.
6. Keep children under the age of 12 and pets away from the weight system at all times.
7. Keep hands and feet away from moving parts.
8. Always wear athletic shoes for foot protection when using the weight system.
9. The weight system is designed to support a maximum user weight of 300 pounds.
10. Never release the press arm, butterfly arms, leg lever, leg press base, lat bar, ab strap, or handle while weights are raised; the weights will fall with great force.
11. Make sure that the cables remain on the pulleys at all times. If the cables bind while you are exercising, stop immediately and make sure that the cables are on all of the pulleys.
12. Always stand on the foot plate when performing an exercise that could cause the weight system to tip.
13. *Always disconnect the lat bar from the weight system when performing an exercise that does not use the lat bar.*
14. If you feel pain or dizziness at any time while exercising, stop immediately and begin cooling down.
15. The warning decals shown here have been placed on the weight system in the locations shown on page 4. If a decal is missing or illegible, please call our toll-free HELPLINE at 1-800-736-6879, Monday through Saturday, 7 a.m. until 7 p.m. Central Time, to order a free replacement decal. Place the decal on the weight system in the location shown.

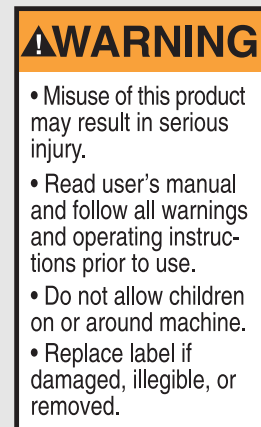

Decal 1



Decal 2

⚠ WARNING: Before beginning this or any exercise program, consult your physician. This is especially important for persons over the age of 35 or persons with pre-existing health problems. Read all instructions before using. SEARS assumes no responsibility for personal injury or property damage sustained by or through the use of this product.

BEFORE YOU BEGIN

Thank you for selecting the versatile WEIDER® PRO 4100 weight system. The PRO 4100 weight system offers a selection of weight stations designed to develop every major muscle group of the body. Whether your goal is to tone your body, build dramatic muscle size and strength, or improve your cardiovascular system, the weight system will help you to achieve the results you want.

For your benefit, read this manual carefully before using the weight system. If you have additional questions, please call our toll-free HELPLINE at

1-800-736-6879, Monday through Saturday, 7 a.m. until 7 p.m. Central Time (excluding holidays). To help us assist you, please note the product model number and serial number before calling. The model number is 831.159823. The serial number can be found on a decal attached to the weight system (see the front cover of this manual).

Before reading further, please review the drawing below and familiarize yourself with the parts that are labeled.

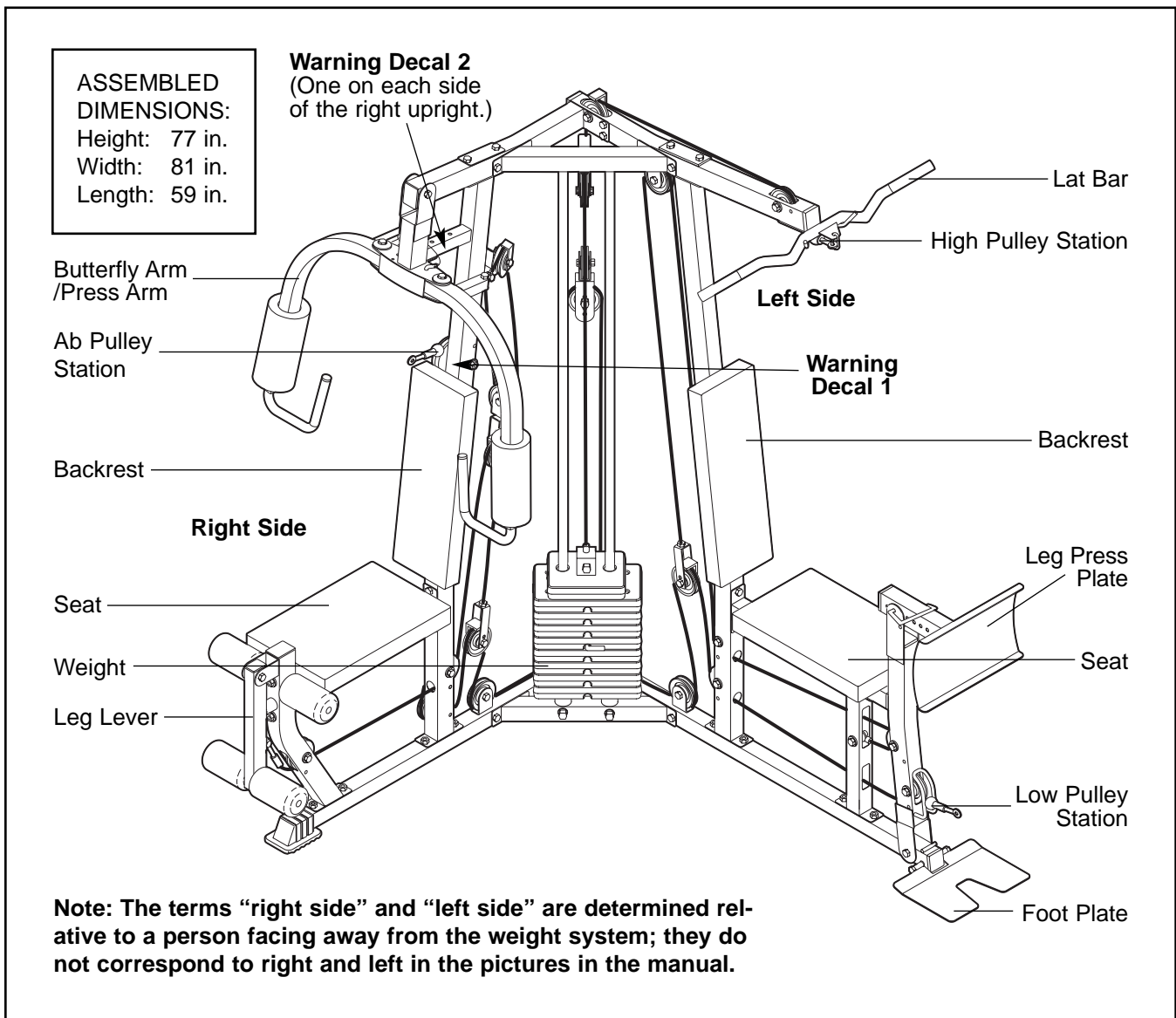

ASSEMBLY

Make Things Easier for Yourself

Everything in this manual is designed to ensure that the weight system can be assembled successfully by anyone. However, it is important to realize that the versatile weight system has many parts and that the assembly process will take time. Most people find that by setting aside plenty of time, assembly will go smoothly.



Before beginning assembly, carefully read the following information and instructions:

- Assembly requires two people.
- Place all parts in a cleared area and remove the packing materials. Do not dispose of the packing materials until assembly is completed.
- Tighten all parts as you assemble them, unless instructed to do otherwise.

- As you assemble the weight system, make sure all parts are oriented as shown in the drawings.

- **For help identifying small parts, use the PART IDENTIFICATION CHART.**

An Allen wrench (included) and the following tools (not included) are required for assembly:

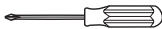
- two adjustable wrenches 
- one rubber mallet 
- one standard screwdriver 
- one Phillips screwdriver 
- lubricant, such as grease or petroleum jelly, and soapy water.

Assembly will be more convenient if you have a socket set, a set of open-end or closed-end wrenches, or a set of ratchet wrenches.

FRAME ASSEMBLY

1. **Before beginning assembly, be sure that you have read and understand the information in the box above.**

Attach the Base Cap (28) to the Right Base (1) with two #8 x 3/4" Screws (68).

Attach the Center Base (67) to the Right Base (1) with two 5/16" x 2 3/4" Bolts (60), two 5/16" Washers (26), and two 5/16" Nylon Locknuts (71).

Insert four 5/16" x 2 1/2" Carriage Bolts (57) up into the Right Base (1).

2. Press two 2" Square Inner Caps (33) into the ends of the Left Base (2). Attach the Rubber Bumper (98) to the Left Base with a #8 x 3/4" Screw (68).

Insert four 5/16" x 2 1/2" Carriage Bolts (57) up into the Left Base (2).

Attach the Left Base (2) to the Right Base (1) and Center Base (67) with three 5/16" x 2 3/4" Bolts (60), three 5/16" Washers (26), and three 5/16" Nylon Locknuts (71).

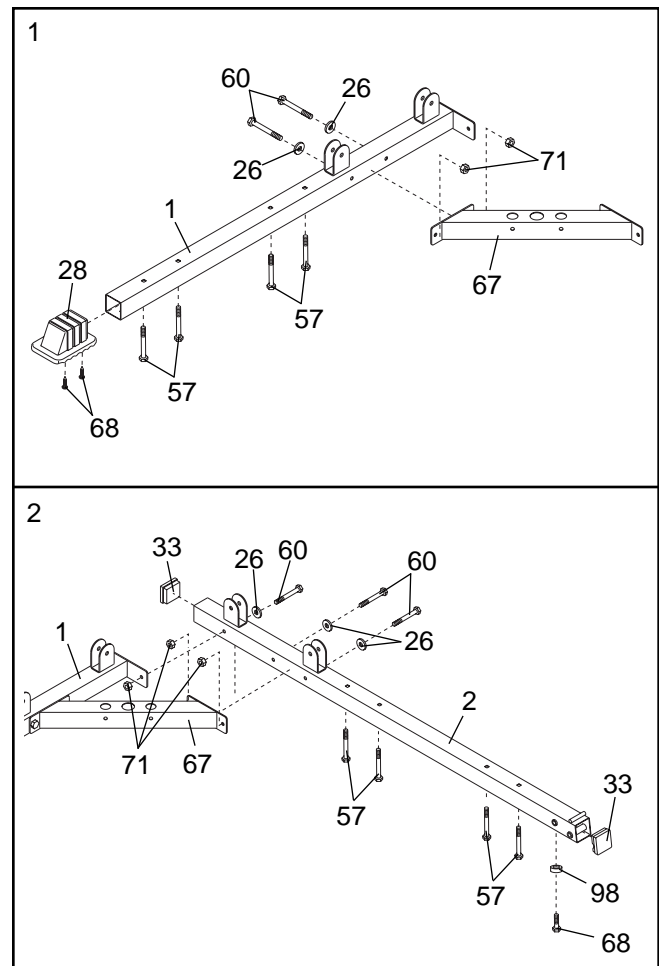

3. Attach the Base Plate (37) to the Left Base (2) with a 3/8" x 5 1/2" Bolt (58) and a 3/8" Nylon Locknut (70).

Attach the Left Upright (7) to the Left Base (2) with the two indicated 5/16" x 2 1/2" Carriage Bolts (57) and two 5/16" Nylon Locknuts (71).

Attach the Left Leg (36) to the Left Base (2) with the two indicated 5/16" x 2 1/2" Carriage Bolts (57) and two 5/16" Nylon Locknuts (71). **Be sure the large upper hole in the Left Leg is on the side shown.**

Do not tighten the 5/16" Nylon Locknuts (71) yet.

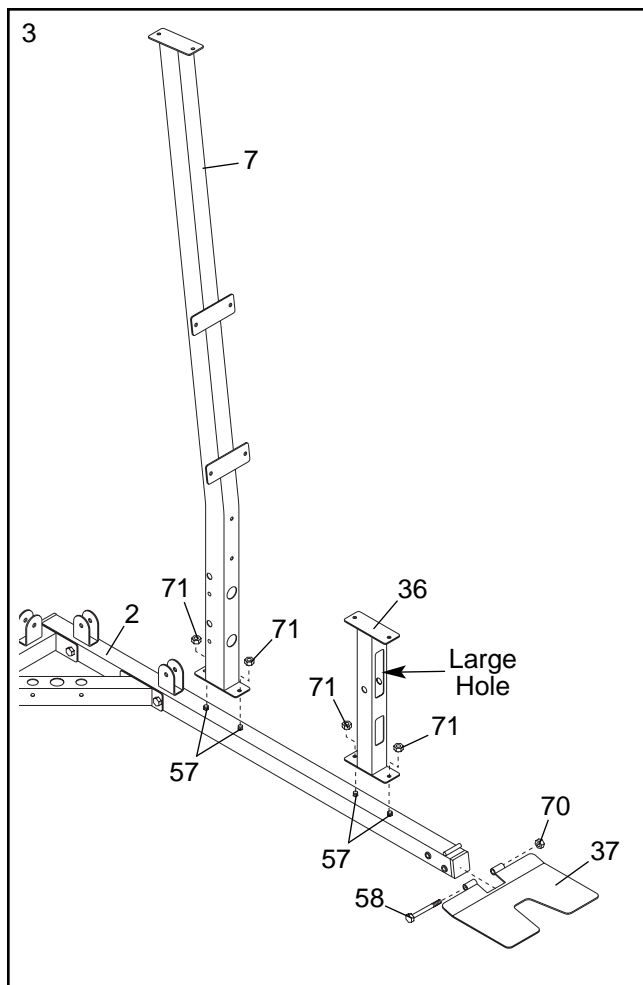

4. Press a 2" x 2 1/2" Inner Cap (22) into the top of the Right Leg (73).

Attach the Right Upright (6) to the Right Base (1) with the two indicated 5/16" x 2 1/2" Carriage Bolts (57) and two 5/16" Nylon Locknuts (71).

Attach the Right Leg (73) to the Right Base (1) with the two indicated 5/16" x 2 1/2" Carriage Bolts (57) and two 5/16" Nylon Locknuts (71).

Do not tighten the 5/16" Nylon Locknuts (71) yet.

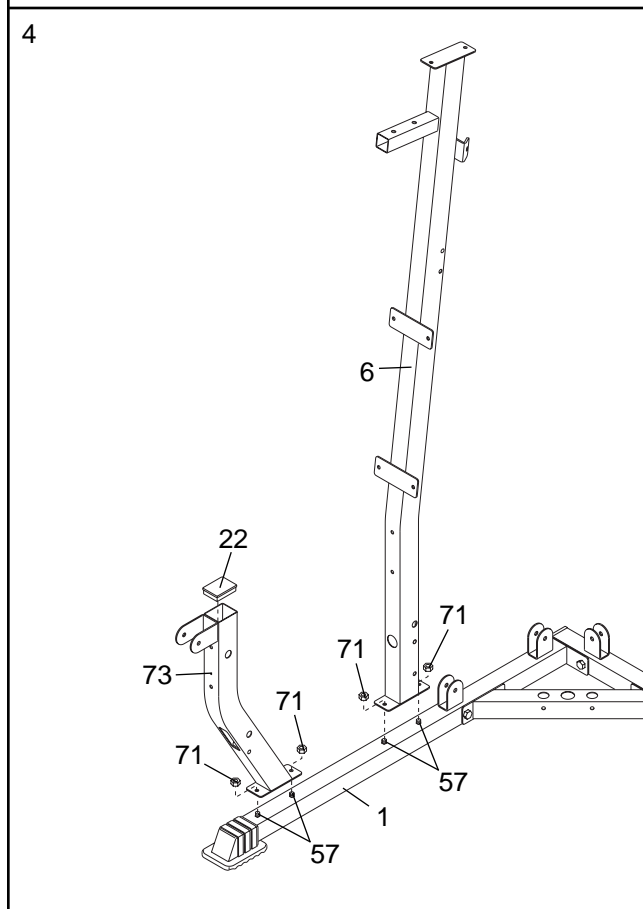

- Attach the Right Seat Frame (5) to the Right Leg (73) with two 5/16" x 3 1/4" Bolts (59), two 5/16" Washers (26), and two 5/16" Nylon Locknuts (71).

Attach the Right Seat Frame (5) to the Right Upright (6) with two 5/16" x 3 1/4" Bolts (59), two 5/16" Washers (26), and two 5/16" Nylon Locknuts (71).

Do not tighten the 5/16" Nylon Locknuts (71) yet.

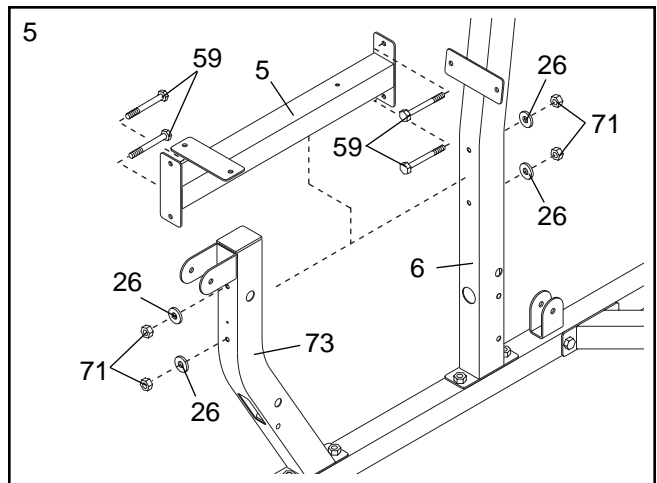

- Press a 2" Square Inner Cap (33) into the end of the Left Seat Frame (29).

Attach the Left Seat Frame (29) to the Left Leg (36) with two 5/16" x 2 1/2" Carriage Bolts (57) and two 5/16" Nylon Locknuts (71).

Attach the Left Seat Frame (29) to the Left Upright (7) with two 5/16" x 3 1/4" Bolts (59), two 5/16" Washers (26), and two 5/16" Nylon Locknuts (71).

Do not tighten the 5/16" Nylon Locknuts (71) yet.

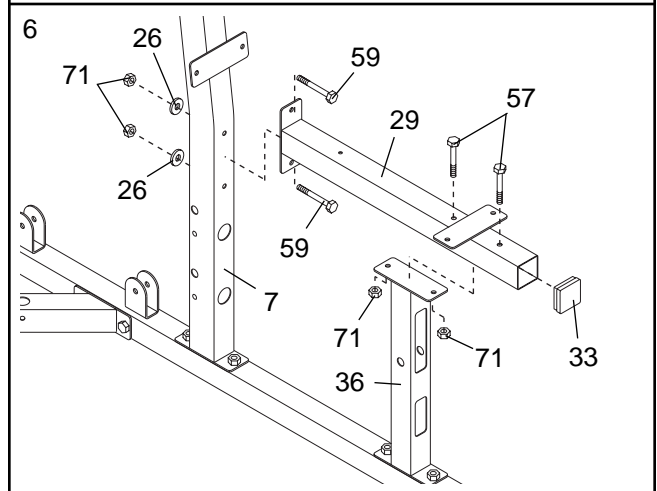

- Set two Weight Bumpers (83) over the indicated holes in the Center Base (67). Insert the two Weight Guides (20) into the holes. Attach the Weight Guides to the Center Base with two 5/16" x 2 3/4" Bolts (60), four 5/16" Washers (26), and two 5/16" Nylon Locknuts (71).

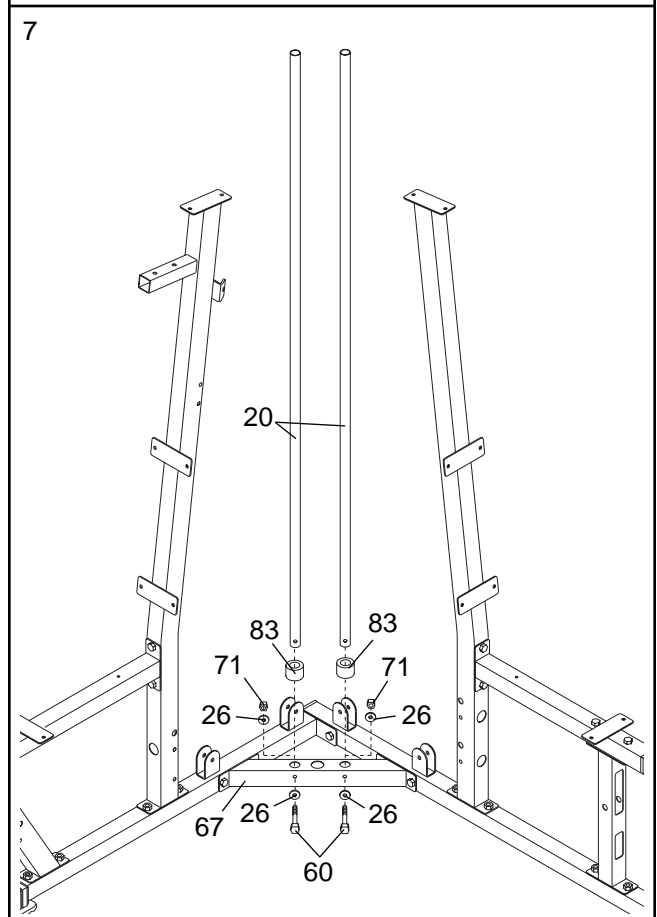

- Slide the eight Weights (72) onto the Weight Guides (20) with the pin grooves on the side shown.

Press the Weight Tube Bumper (32) into the bottom of the Weight Tube (82). Insert the Weight Tube into the center hole in the stack of Weights (72). **Be sure the Weight Tube is oriented as shown.**

Lubricate the indicated holes in the Top Weight (74). Slide the Top Weight onto the Weight Guides (20), with the pin groove on the bottom.

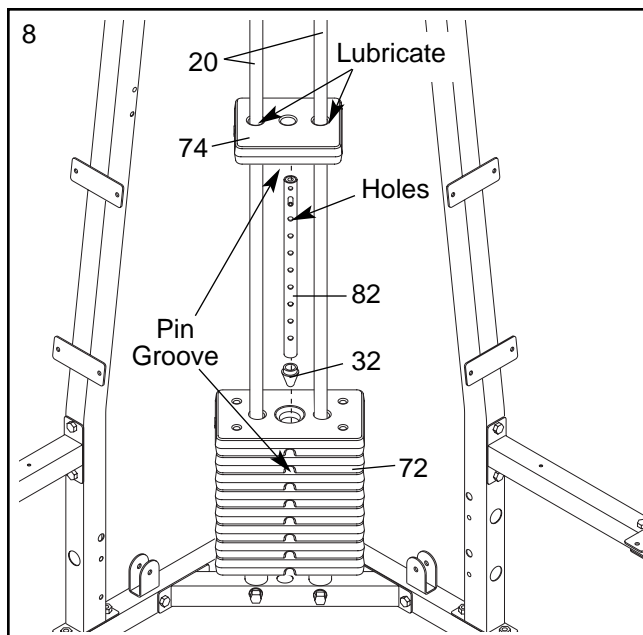

- Press two 2" x 2 1/2" Inner Caps (22) into the ends of the Left Top Frame (3).

Attach the Left Top Frame (3) to the Left Upright (7) with two 5/16" x 3 1/4" Bolts (59), a Support Plate (21), and two 5/16" Nylon Locknuts (71). **Do not tighten the Locknuts yet.**

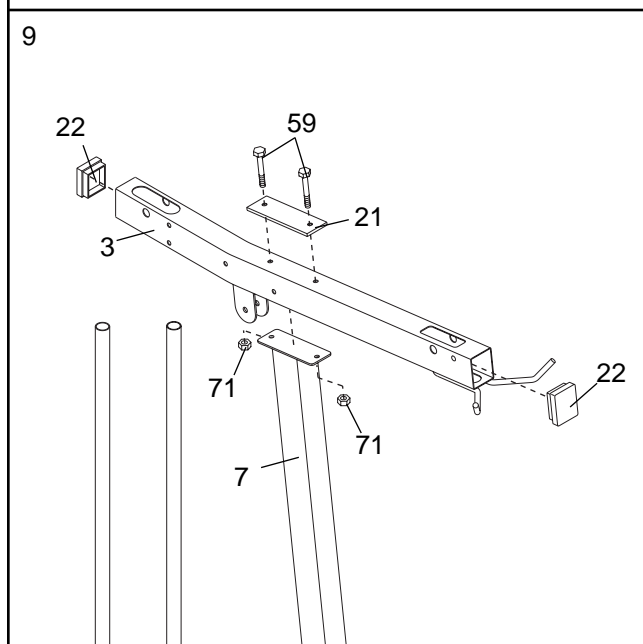

- Press a 2" x 2 1/2" Inner Cap (22) into the end of the Right Top Frame (8).

Attach the Right Top Frame (8) to the Right Upright (6) with two 5/16" x 3 1/4" Bolts (59), a Support Plate (21), and two 5/16" Nylon Locknuts (71).

Attach the Right Top Frame (8) to the Left Top Frame (3) with two 5/16" x 2 3/4" Bolts (60), two 5/16" Washers (26), and two 5/16" Nylon Locknuts (71).

Do not tighten the 5/16" Nylon Locknuts (71) yet.

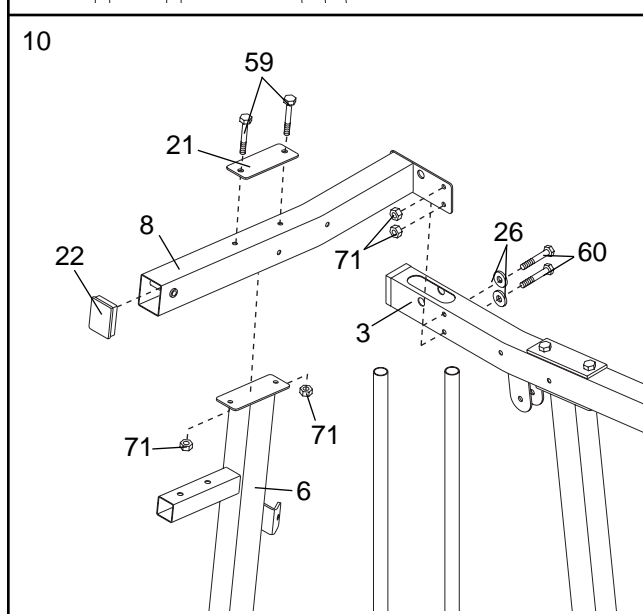

11. Press the two Weight Guide Bushings (44) into the Center Top Frame (14). Slide the Center Top Frame onto the Weight Guides (20).

Attach the Center Top Frame (14) to the Right Top Frame (8) with two 5/16" x 2 3/4" Bolts (60), two 5/16" Washers (26), and two 5/16" Nylon Locknuts (71).

Attach the Center Top Frame (14) to the Left Top Frame (3) with two 5/16" x 2 3/4" Bolts (60), two 5/16" Washers (26), and two 5/16" Nylon Locknuts (71).

Tighten all of the 5/16" Nylon Locknuts (71) used in steps 3–11.

Note: The remaining hardware from the "Frame Assembly" bag will be used later.

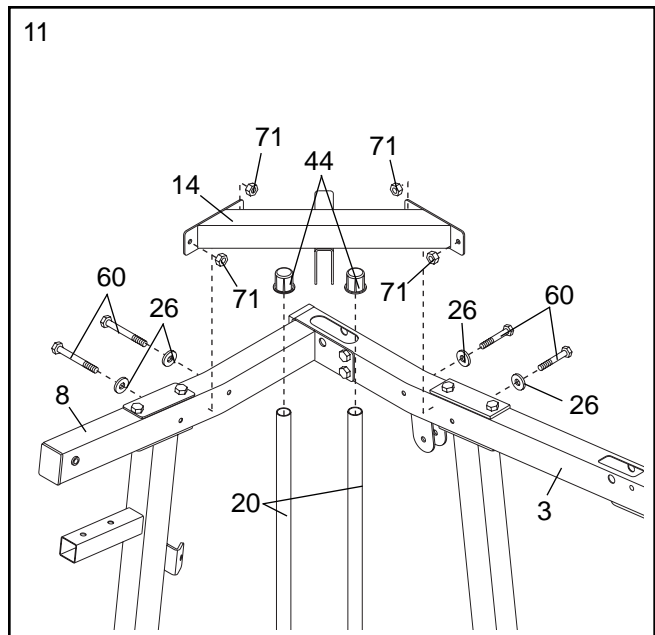

ARM ASSEMBLY

12. Press a 1 1/2" Square Inner Cap (41) into the Right Upright (6). Press a 2" x 2 1/2" Inner Cap (22) into the Butterfly Frame (9).

Lubricate a 3/8" x 3" Bolt (61) with grease. Attach the Butterfly Frame (9) to the Right Top Frame (8) with the Bolt and a 3/8" Nylon Locknut (70). **Do not overtighten the Locknut; the Butterfly Frame must be able to pivot easily.**

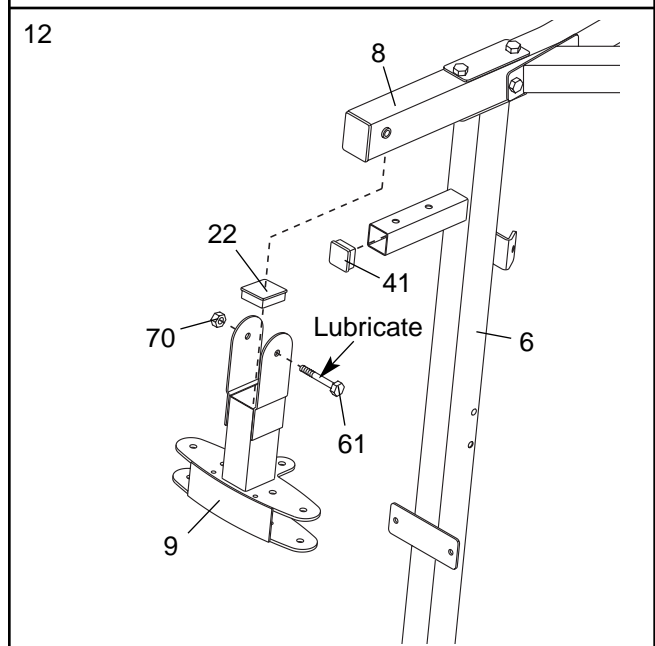

13. Lubricate a 3/8" x 2" Bolt (62) with grease. Attach the Pivot Bracket (48) to the Right Butterfly Arm (11) with the Bolt and a 3/8" Nylon Jamnut (50). **Do not overtighten the Locknut; the Pivot Bracket must be able to pivot easily.**

Press a 1 1/2" x 2" Inner Cap (23) into the indicated end of the Right Butterfly Arm (11). Wet the bottom end of the Arm with soapy water. Slide a Large Foam Pad (19) onto the Arm.

Slide a Foam Grip (76) onto a Press Handle (12). Press a 1" Round Inner Cap (24) into the end of the Handle. Attach the Handle to the Right Butterfly Arm (11) with two 5/16" x 3/4" Button Head Screws (64) and two Nut Clips (99).

Slide the Large Foam Pad (19) down so that the bottom of the Foam Pad is even with the bottom of the Right Butterfly Arm (11).

Repeat this step with the Left Butterfly Arm (10).

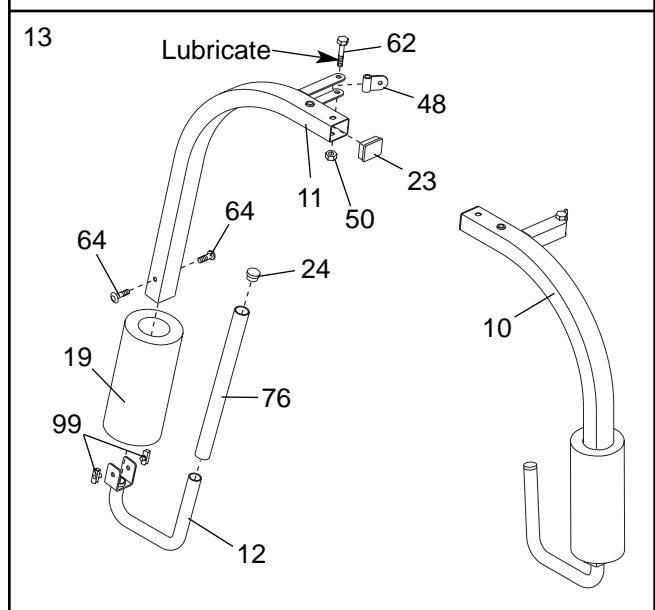

14. Lubricate a 3/8" x 3" Button Head Bolt (97) and both sides of two Plastic Washers (55) with grease. Attach the Right Butterfly Arm (11) to the Butterfly Frame (9) with the Bolt, the two Plastic Washers, two Butterfly Caps (54), two 3/8" Washers (75), and a 3/8" Nylon Jamnut (50). **Do not overtighten the Jamnut; the Butterfly Arm must be able to pivot easily. Be sure the indented sides of the Plastic Washers fit over the welded bushing in the Butterfly Arm.**

Repeat this step with the Left Butterfly Arm (10).

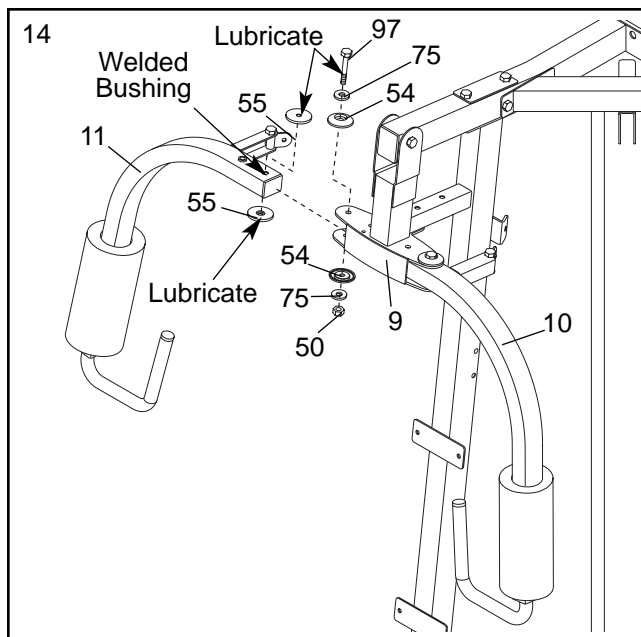

15. Attach the Bumper (25) to the Right Leg (73) with the #10 x 1" Screw (77).

Press two 1 1/2" x 2" Inner Caps (23) into the ends of the Leg Lever (4).

Lubricate a 3/8" x 2 1/2" Bolt (63) with grease. Attach the Leg Lever (4) to the Right Leg (73) with the Bolt and a 3/8" Nylon Jamnut (50). **Do not overtighten the Jamnut; the Leg Lever must be able to pivot easily.**

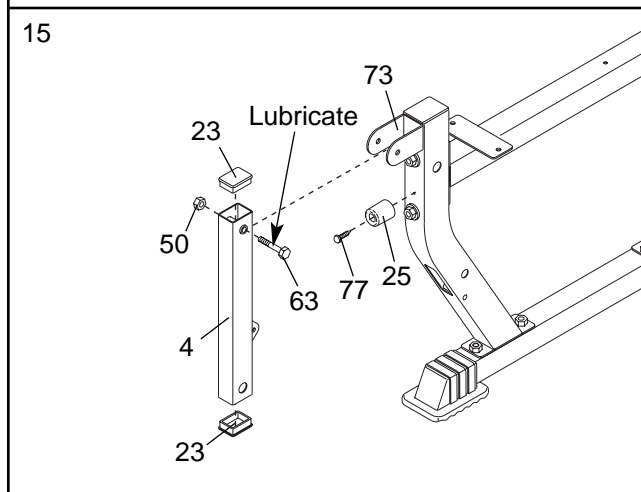

16. Press a 2" x 2 1/2" Inner Cap (22) into the top of the Leg Press Frame (30).

Lubricate a 3/8" x 3" Bolt (61) with grease. Attach the Leg Press Frame (30) to the Left Base (2) with the Bolt and a 3/8" Nylon Locknut (70). **Do not overtighten the Locknut; the Leg Press Frame must be able to pivot easily.**

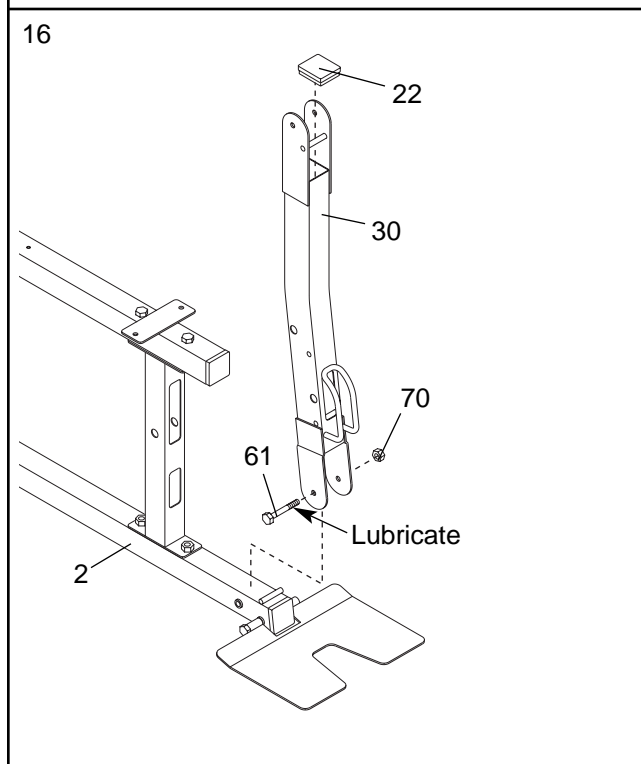

CABLE ASSEMBLY

17. **IMPORTANT:** While assembling the cables, do not over tighten the locknuts attaching the pulleys; the pulleys must be able to turn freely. Refer to the **CABLE DIAGRAMS** and **CABLE ID CHART** on pages 24 and 25 for proper cable routing and help identifying the cables.

Locate the High Cable (45). Route the Cable up through the Left Top Frame (3) and around a 3 1/2" Pulley (38). Attach the Pulley inside the Top Frame with a 3/8" x 2 3/4" Bolt (81), two 3/8" Washers (75), two 1/2" Spacers (34), and a 3/8" Nylon Locknut (70).

18. Route the High Cable (45) around a 3 1/2" Pulley (38) and down through the Left Top Frame (3). Attach the Pulley and a Cable Trap (91) inside the Top Frame with a 3/8" x 2 3/4" Bolt (81), two 3/8" Washers (75), two 1/2" Spacers (34), and a 3/8" Nylon Locknut (70). **Be sure the Cable Trap is turned to hold the Cable in the groove of the Pulley.**

Note: To complete this step, it may be necessary to loosen the four indicated 5/16" Nylon Locknuts (71). Retighten the Locknuts when this step is completed.

19. **Remove the preassembled 3 1/2" Pulleys (38) from a Double "U"-Bracket (56).**

Wrap the High Cable (45) around a 3 1/2" Pulley (38). Attach the Pulley to the single hole side of a Double "U"-Bracket (56) with a 3/8" x 2" Bolt (62) and a 3/8" Nylon Locknut (70).

20. **Note:** The following drawings are shown from the left side of the weight system, with the Left Top Frame (3) removed for clarity.

Wrap the High Cable (45) around a 3 1/2" Pulley (38). Attach the Pulley at the rear hole, inside of the bracket on the Center Top Frame (14) with a 3/8" x 1 3/4" Bolt (66) and a 3/8" Nylon Locknut (70).

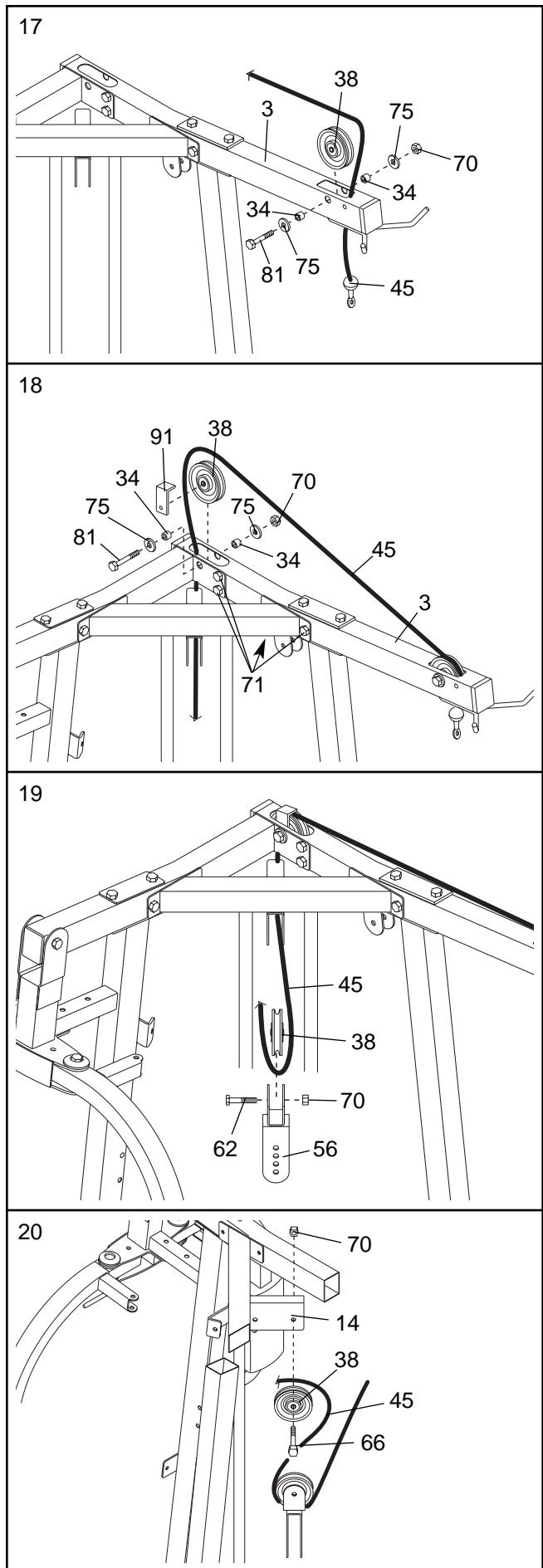

21. Wrap the High Cable (45) around a 3 1/2" Pulley (38). Attach the Pulley at the forward hole, inside of the bracket on the Center Top Frame (14) with a 3/8" x 1 3/4" Bolt (66) and a 3/8" Nylon Locknut (70).

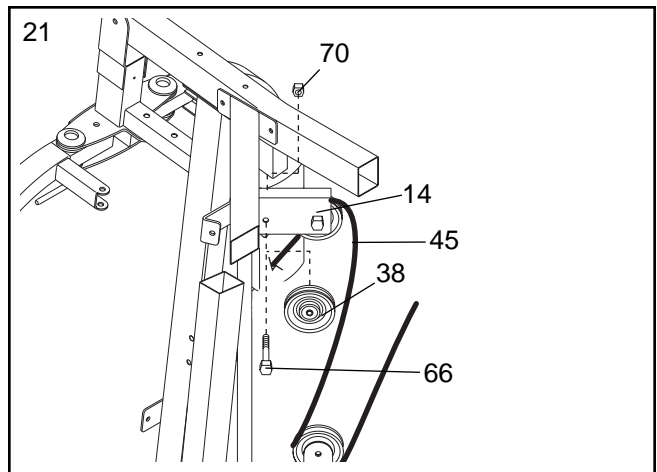

22. Attach the end of the High Cable (45) to the Small "U"-Bracket (79) with a 1/4" Washer (35) and a 1/4" Nylon Locknut (65). **Note: Do not completely tighten the Nylon Locknut; it should be threaded only two turns onto the end of the Cable, as shown in the inset drawing.**

Attach the Small "U"-Bracket (79) to the Weight Tube (82) with a 5/16" x 1 3/4" Bolt (69) and a 5/16" Nylon Locknut (71). **Do not overtighten the Locknut; the Weight Tube should be able to pivot in the "U"-Bracket.**

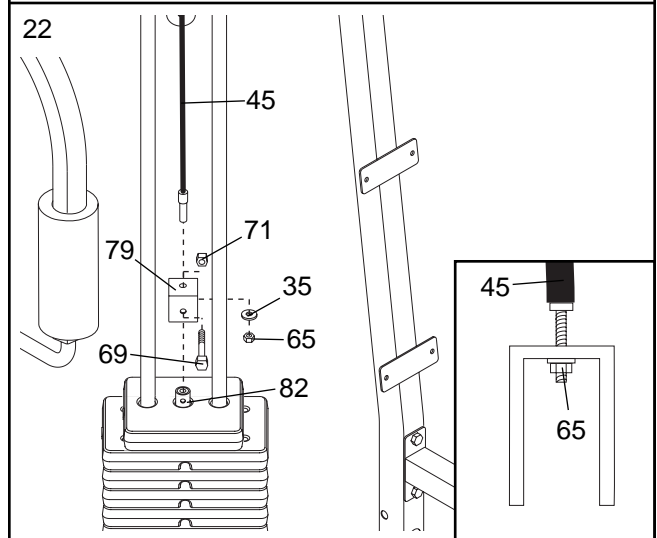

23. **Locate the Leg Press Cable (95).** Attach the Cable inside the Left Leg (36) with a 3/8" x 2 3/4" Bolt (81), two 3/8" Washers (75), two Long Spacers (80), and a 3/8" Nylon Locknut (70).

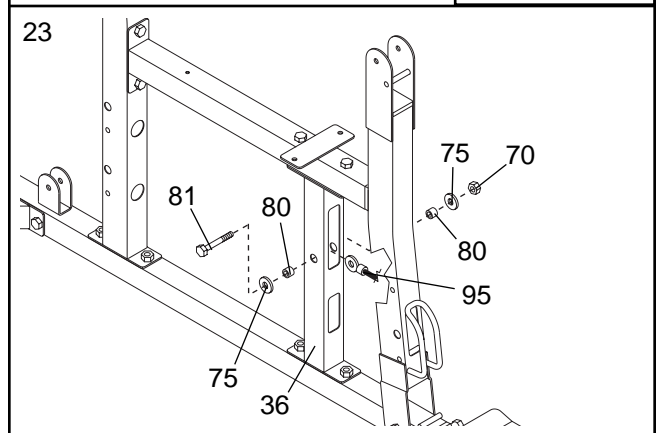

24. Wrap the Leg Press Cable (95) around a 3 1/2" Pulley (38). Attach the Pulley inside the Leg Press Frame (30) with a 3/8" x 2 3/4" Bolt (81), two 3/8" Washers (75), two 1/2" Spacers (34), and a 3/8" Nylon Locknut (70).

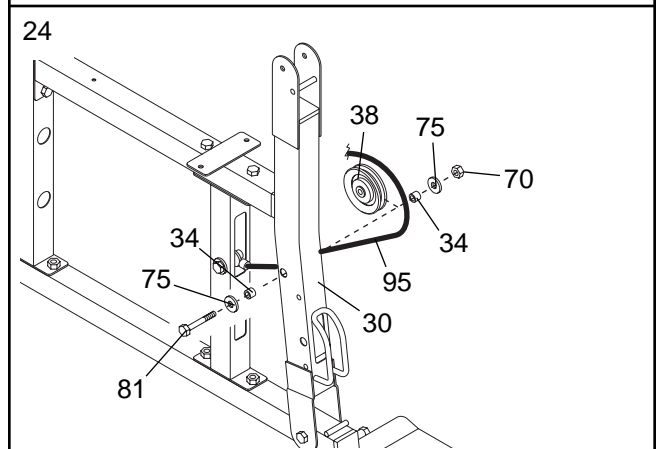

25. Route the Leg Press Cable (95) through the Left Leg (36) and the Left Upright (7) as shown. Wrap the Cable around a 3 1/2" Pulley (38). Attach the Pulley inside the Upright with a 3/8" x 2 3/4" Bolt (81), two 3/8" Washers (75), two 1/2" Spacers (34), and a 3/8" Nylon Locknut (70).

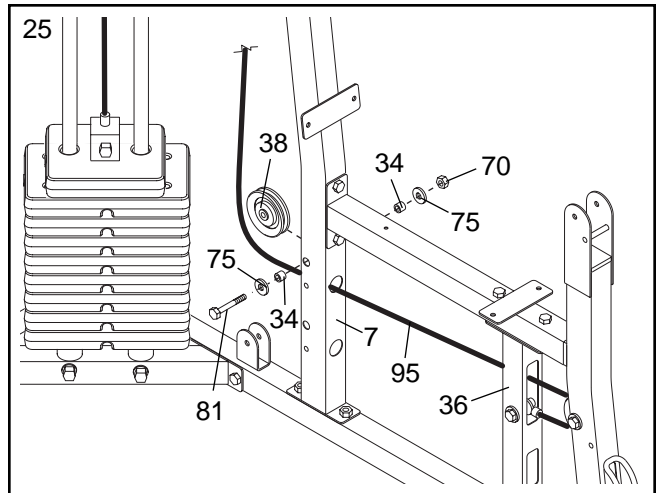

26. Wrap the Leg Press Cable (95) around a 3 1/2" Pulley (38). Attach the Pulley inside the bracket on the Left Top Frame (3) with a 3/8" x 2" Bolt (62) and a 3/8" Nylon Locknut (70).

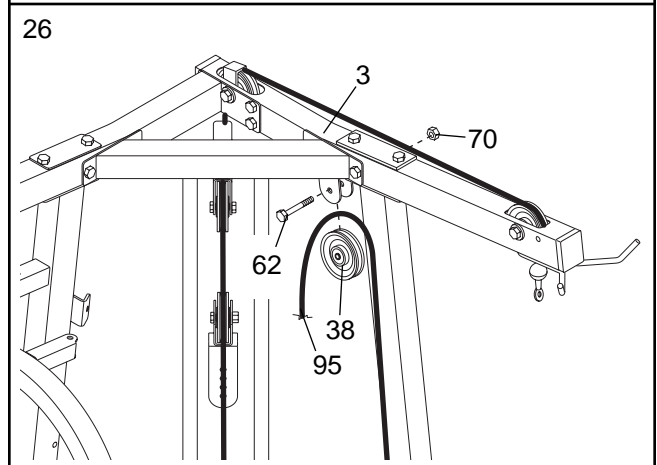

27. Remove the preattached 3 1/2" Pulley (not shown) from the "U"-Bracket (85).

Attach the end of the Leg Press Cable (95) to the "U"-Bracket (85) with a 1/4" Washer (35) and a 1/4" Nylon Locknut (65). **Note: Do not completely tighten the Locknut; it should be threaded only two turns onto the end of the Cable, as shown in the inset drawing.**

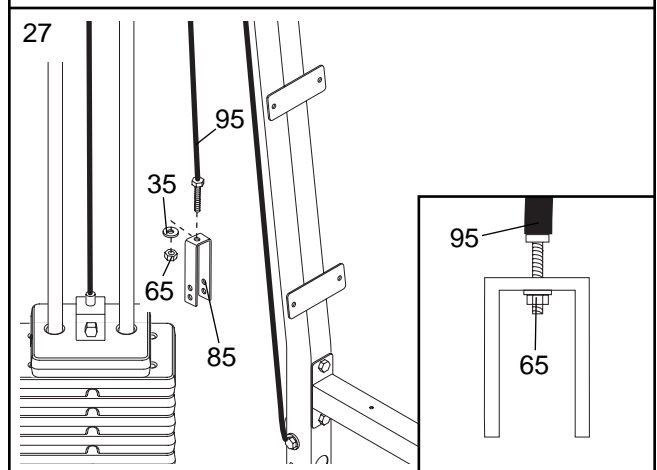

28. **Locate the Butterfly Cable (46).** Attach the Cable to the Pivot Bracket (48) on the Left Butterfly Arm (10) with an 5/16" x 1" Shoulder Bolt (78) and a 5/16" Nylon Locknut (71).

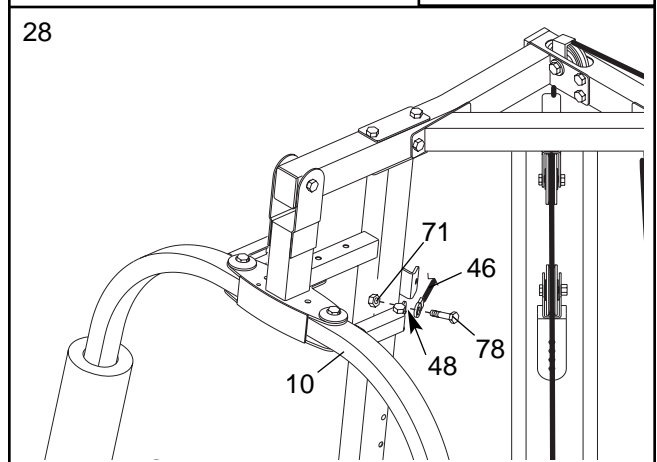

29. Wrap the Butterfly Cable (46) around a “V”-Pulley (39). Attach the Pulley and a Long Cable Trap (40) to the bracket on the Right Upright (6) with a 3/8” x 2 1/2” Bolt (63) and a 3/8” Nylon Locknut (70). **Be sure the Cable Trap is turned to hold the Cable in the groove of the Pulley.**

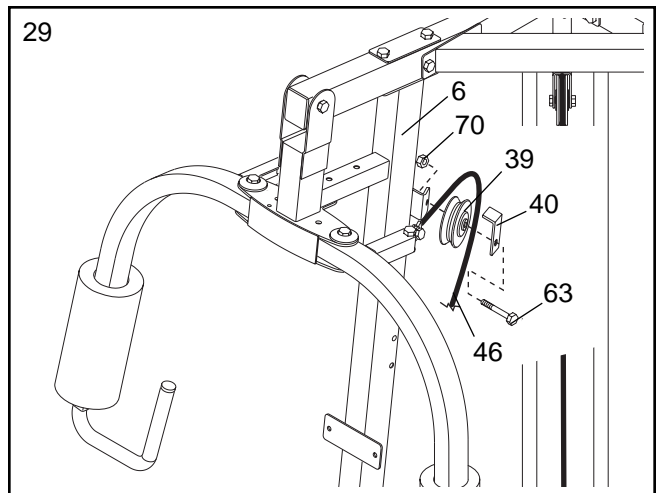

30. **Remove the preattached 3 1/2” Pulleys (38) from the Double “U”-Bracket (56).**

Wrap the Butterfly Cable (46) around a 3 1/2” Pulley (38). Attach the Pulley to the single hole side of the other Double “U”-Bracket (56) with a 3/8” x 2” Bolt (62) and a 3/8” Nylon Locknut (70).

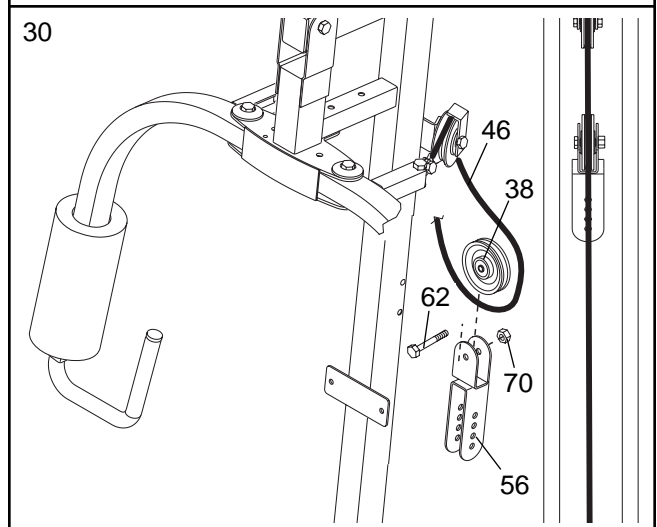

31. Wrap the Butterfly Cable (46) around a “V”-Pulley (39). Attach the Pulley and a Long Cable Trap (40) to the bracket on the Right Upright (6) with a 3/8” x 2 1/2” Bolt (63) and a 3/8” Nylon Locknut (70). **Be sure the Cable Trap is turned to hold the Cable in the groove of the Pulley.**

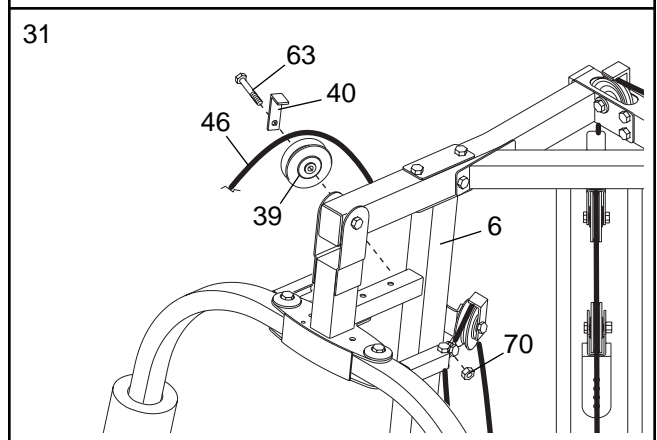

32. Attach the Butterfly Cable (46) to the Pivot Bracket (48) on the Right Butterfly Arm (11) with a 5/16” x 1” Shoulder Bolt (78) and an 5/16” Nylon Locknut (71).

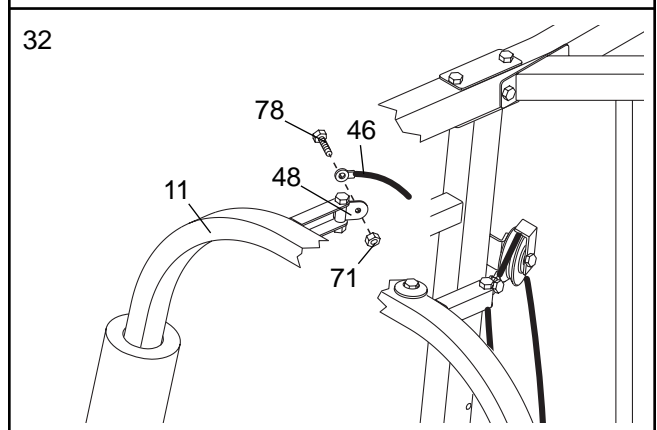

33. **Locate the Leg Lever Cable (96).** Route the eyelet end of the Cable through the Right Leg (73) and attach it to the Leg Lever (4) with a 5/16" x 1" Shoulder Bolt (78) and a 5/16" Nylon Locknut (71).

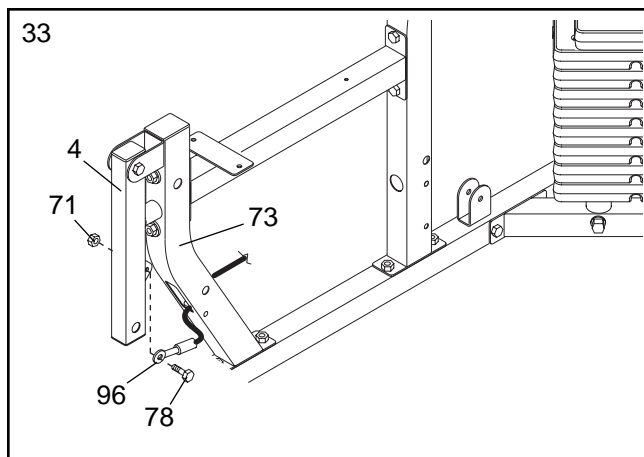

34. Attach a 3 1/2" Pulley (38) inside the Right Leg (73) with a 3/8" x 2 3/4" Bolt (81), two 3/8" Washers (75), two 1/2" Spacers (34), and a 3/8" Nylon Locknut (70).

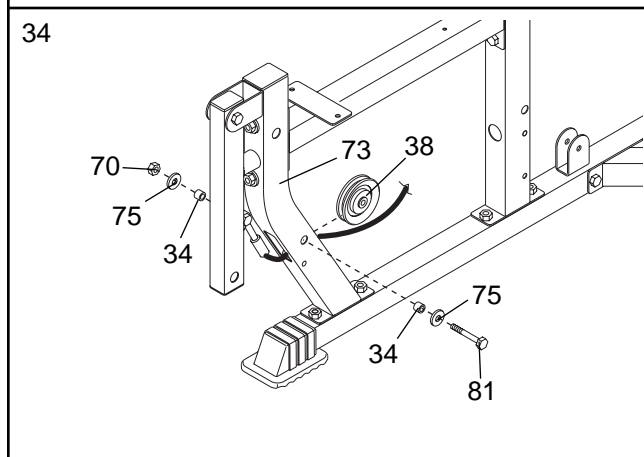

35. Route the Leg Lever Cable (96) through the Right Upright (6) and around a 3 1/2" Pulley (38). Attach the Pulley inside the Upright with a 3/8" x 2 3/4" Bolt (81), two 3/8" Washers (75), two 1/2" Spacers (34), and a 3/8" Nylon Locknut (70).

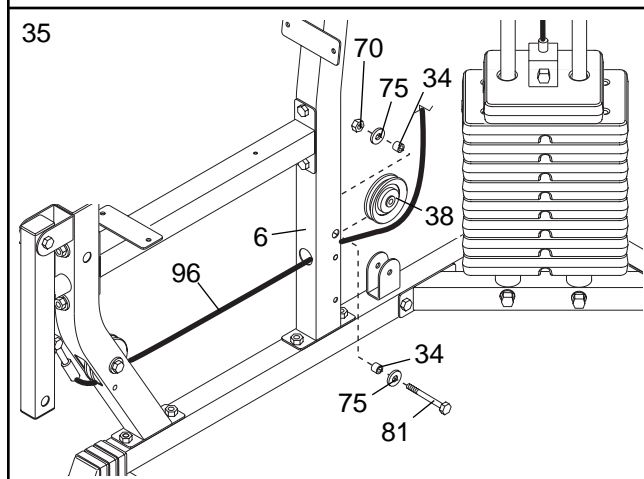

36. Wrap the Leg Lever Cable (96) around a 3 1/2" Pulley (38). Attach the Pulley and a Cable Trap (91) to the bottom set of holes in the indicated Double "U"-Bracket (56) with a 3/8" x 2" Bolt (62) and a 3/8" Nylon Locknut (70). **Be sure the Cable Trap is turned to hold the Cable in the groove of the Pulley.**

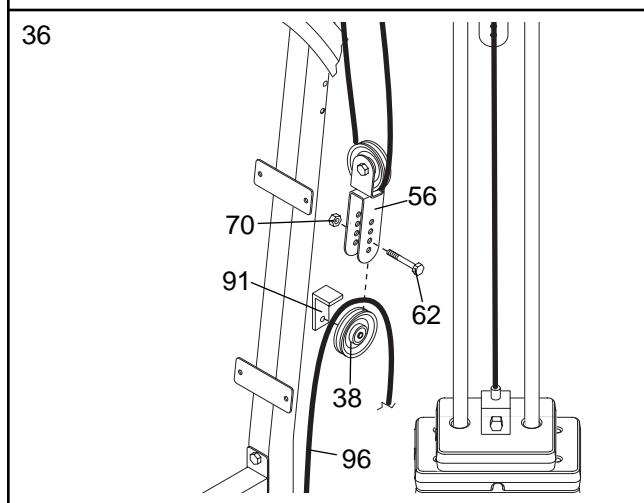

37. Remove the preattached 3 1/2" Pulley (not shown) from the "U"-Bracket (85).

Attach the end of the Leg Lever Cable (96) to the other "U"-Bracket (85) with a 1/4" Washer (35) and a 1/4" Nylon Locknut (65). **Note: Do not completely tighten the Nylon Locknut; it should be threaded only two turns onto the end of the Cable, as shown in the inset drawing.**

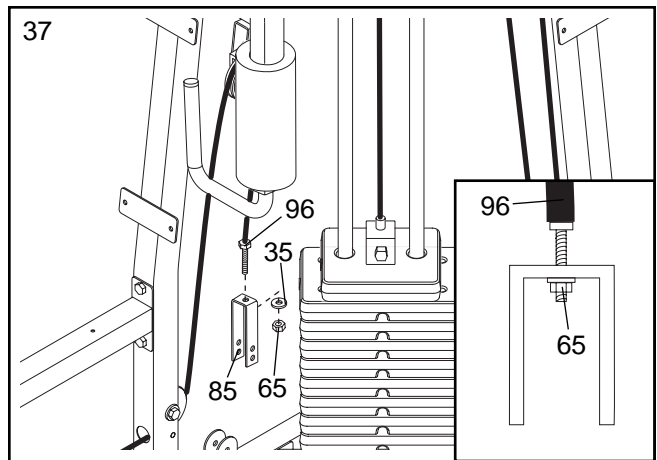

38. **Locate the Low Cable (47).** Route the small ball on the Cable through the cage on the Leg Press Frame (30).

Attach a 3 1/2" Pulley (38) inside the Leg Press Frame (30) with a 3/8" x 2 3/4" Bolt (81), two 3/8" Washers (75), two 1/2" Spacers (34), and a 3/8" Nylon Locknut (70).

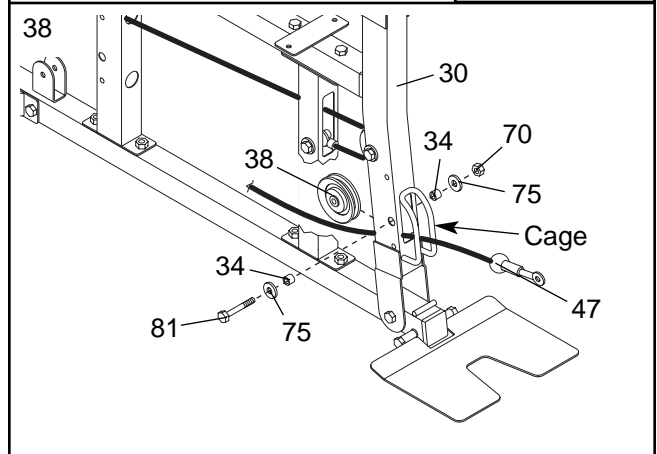

39. Route the Low Cable (47) through the Left Leg (36) and the Left Upright (7). Attach a 3 1/2" Pulley (38) inside the Upright with a 3/8" x 2 3/4" Bolt (81), two 3/8" Washers (75), two 1/2" Spacers (34), and a 3/8" Nylon Locknut (70).

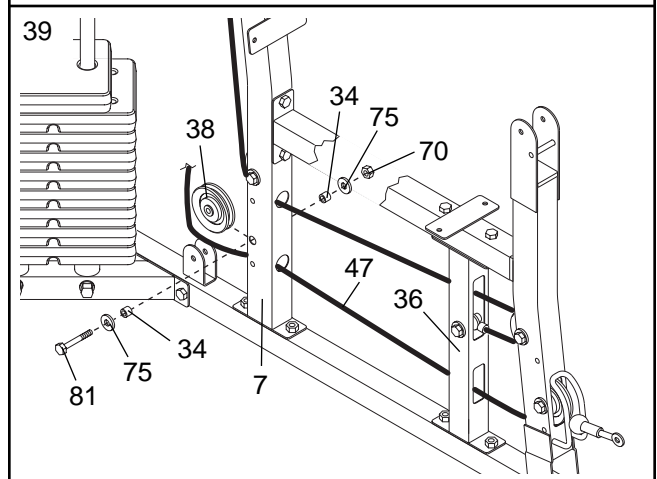

40. Wrap the Low Cable (47) around a 3 1/2" Pulley (38). Attach the Pulley and a Cable Trap (91) to the lower set of holes in the indicated "U"-Bracket (85) with a 3/8" x 2" Bolt (62) and a 3/8" Nylon Locknut (70). **Be sure the Cable Trap is turned to hold the Cable in the groove of the Pulley.**

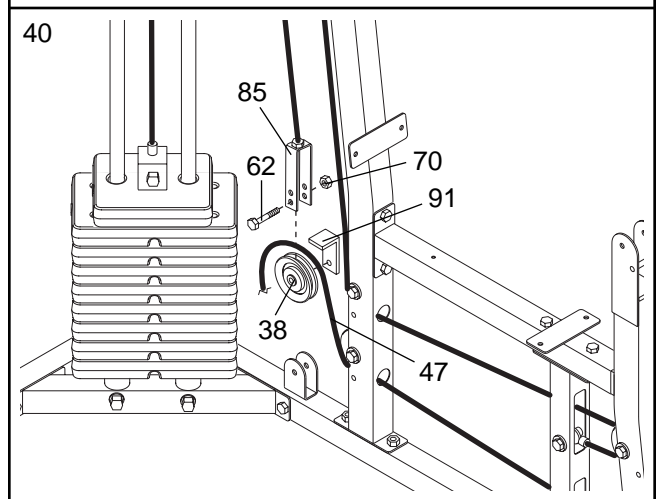

41. Wrap the Low Cable (47) around a 3 1/2" Pulley (38). Attach the Pulley to the indicated bracket on the Left Base (2) with a 3/8" x 2" Bolt (62) and a 3/8" Nylon Locknut (70).

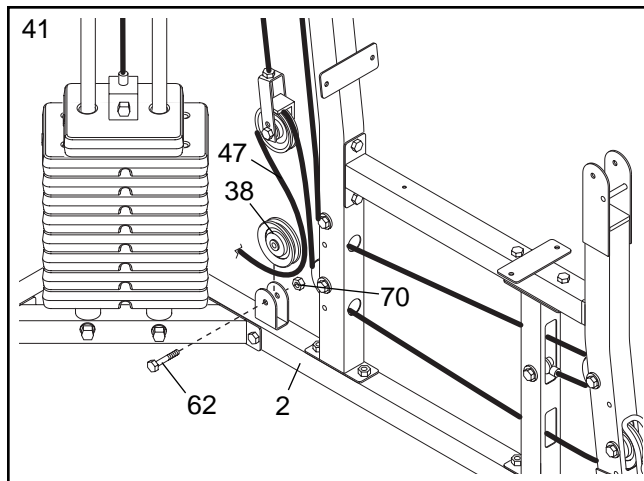

42. Wrap the Low Cable (47) around a 3 1/2" Pulley (38). Attach the Pulley to the indicated bracket on the Left Base (2) with a 3/8" x 2" Bolt (62) and a 3/8" Nylon Locknut (70).

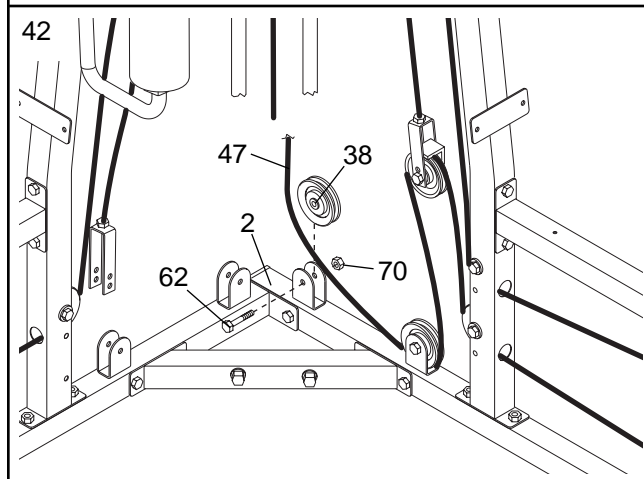

43. Wrap the Low Cable (47) around a 3 1/2" Pulley (38). Attach the Pulley and a Cable Trap (91) to the bottom set of holes in the indicated Double "U"-Bracket (56) with a 3/8" x 2" Bolt (62) and a 3/8" Nylon Locknut (70). **Be sure the Cable Trap is turned to hold the Cable in the groove of the Pulley.**

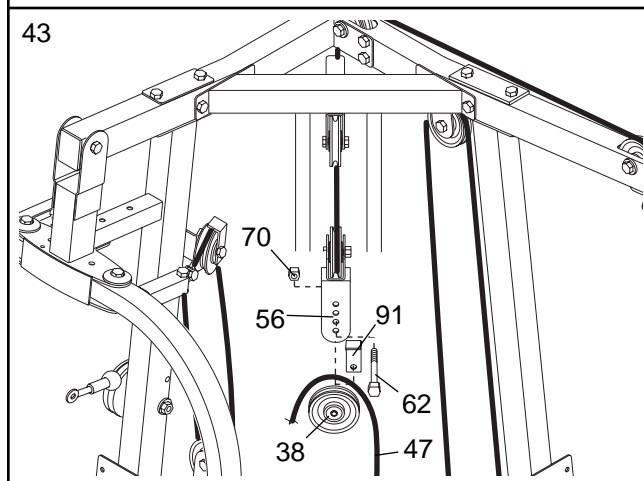

44. Wrap the Low Cable (47) around a 3 1/2" Pulley (38). Attach the Pulley to the indicated bracket on the Right Base (1) with a 3/8" x 2" Bolt (62) and a 3/8" Nylon Locknut (70).

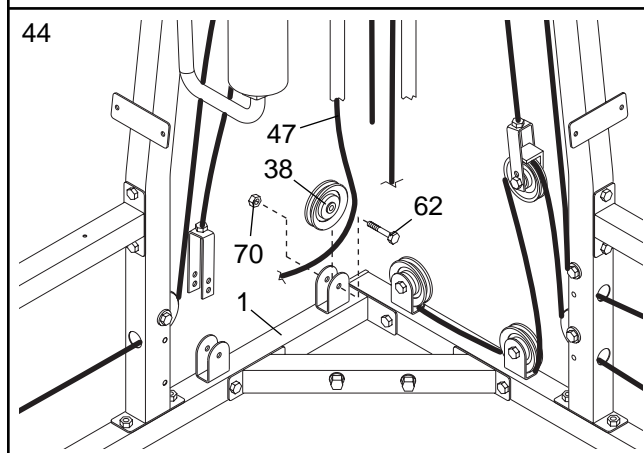

45. Wrap the Low Cable (47) around a 3 1/2" Pulley (38). Attach the Pulley to the indicated bracket on the Right Base (1) with a 3/8" x 2" Bolt (62) and a 3/8" Nylon Locknut (70).

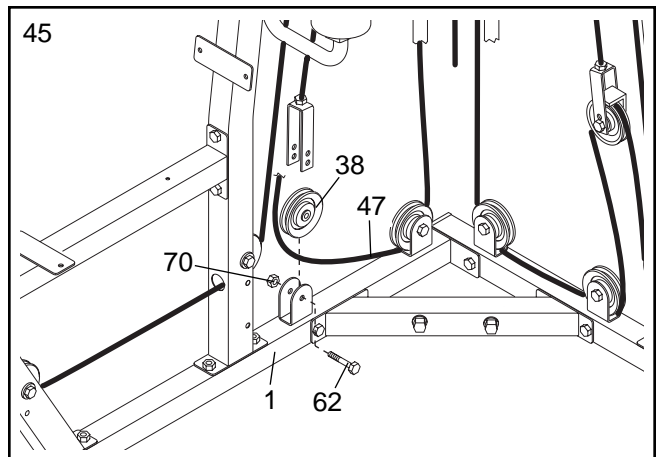

46. Wrap the Low Cable (47) around a 3 1/2" Pulley (38). Attach the Pulley and a Cable Trap (91) to the lower set of holes in the indicated "U"-Bracket (85) with a 3/8" x 2" Bolt (62) and a 3/8" Nylon Locknut (70). **Be sure the Cable Trap is turned to hold the Cable in the groove of the Pulley.**

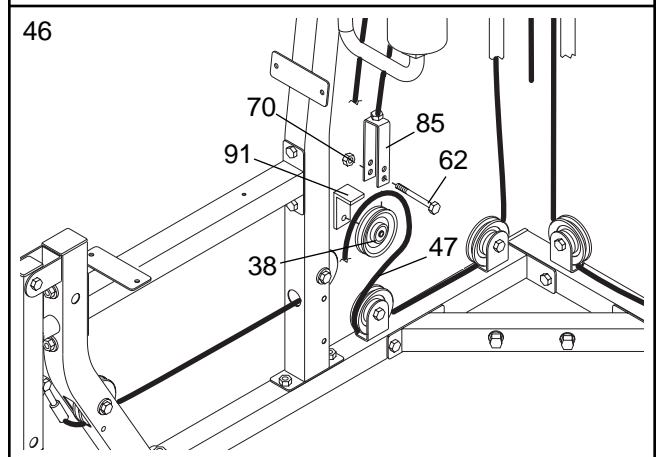

47. Wrap the Low Cable (47) around a 3 1/2" Pulley (38). Attach the Pulley and a Cable Trap (91) to the side of the Right Upright (6) with a 3/8" x 3 3/4" Bolt (84), a 3/8" Washer (75), and a 3/8" Nylon Locknut (70). **Be sure the Cable Trap is turned to hold the Cable in the groove of the Pulley.**

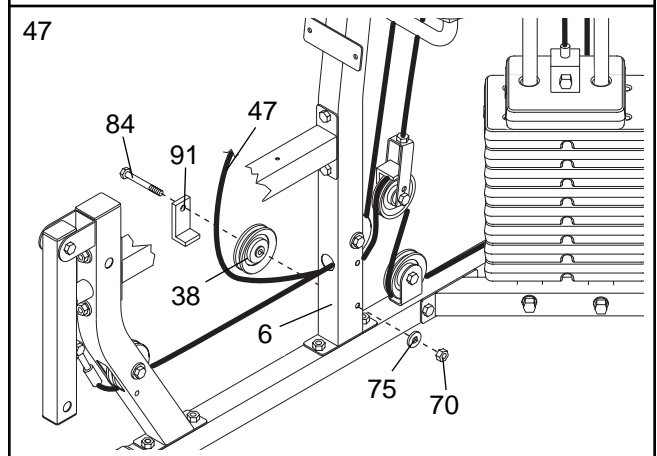

48. Wrap the Low Cable (47) around a 3 1/2" Pulley (38). Attach the Pulley and a pair of Pulley Covers (92) to the Right Upright (6) with a 3/8" x 3 3/4" Bolt (84), two 3/8" Washers (75), and a 3/8" Nylon Jamnut (50). **Be sure the small tabs on the Pulley Covers are on the side shown, and the Cable is between the Pulley and the rod on the Upright.**

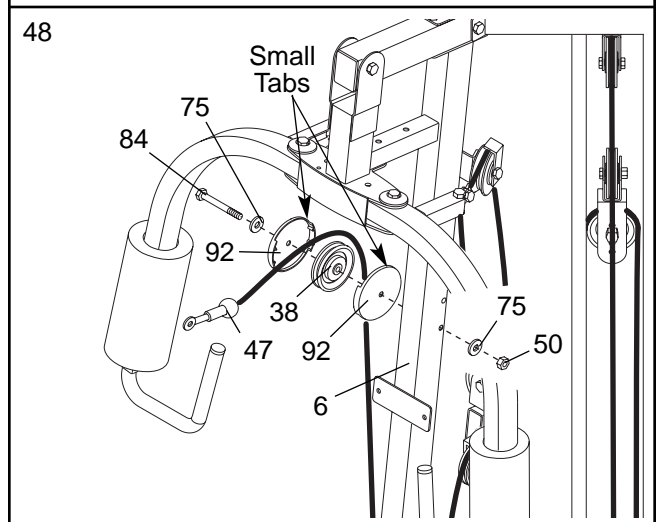

SEAT ASSEMBLY

49. Attach a Seat (16) to the Right Seat Frame (5) with a 1/4" x 2 1/2" Bolt (90), a 1/4" Washer (35), and two 1/4" x 3/4" Bolts (13).

Repeat this step with the other Seat (16) and the Left Seat Frame (not shown).

50. Attach a Backrest (15) to the Right Upright (6) with four 1/4" x 3/4" Bolts (13).

Repeat this step with the other Backrest (15) and the Left Upright (not shown).

51. Slide the Long Pad Tube (17) through the hole in the Right Leg (73). Slide two Foam Pads (18) onto the ends of the Pad Tube. Press two 3/4" Round Inner Caps (27) into the ends of the Pad Tube.

Repeat this step with the Short Pad Tube (94) and the Leg Lever (4).

52. Press a 2" x 2 1/2" Inner Cap (22) into the indicated end of the Adjustment Tube (88).

Attach the Leg Press Plate (31) to the Adjustment Tube (88) with a 5/16" x 2 1/2" Bolt (89), two 5/16" Washers (26), and a 5/16" Nylon Locknut (71).

Attach the Adjustment Tube (88) to the Leg Press Frame (30) with the Leg Press Pin (87). **Be sure the Pin is in the locked position around the Leg Press Frame.**

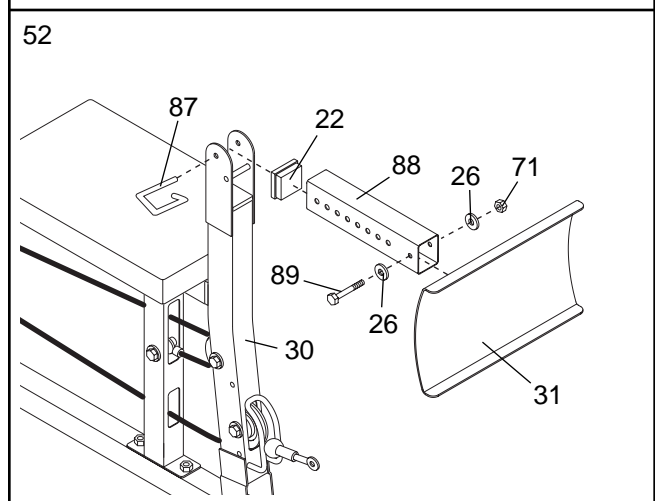
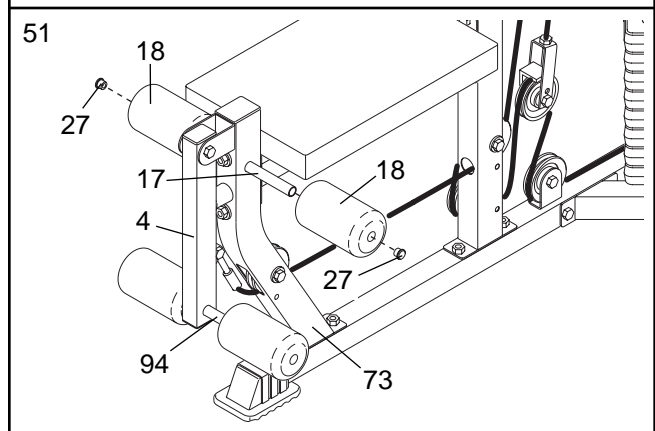
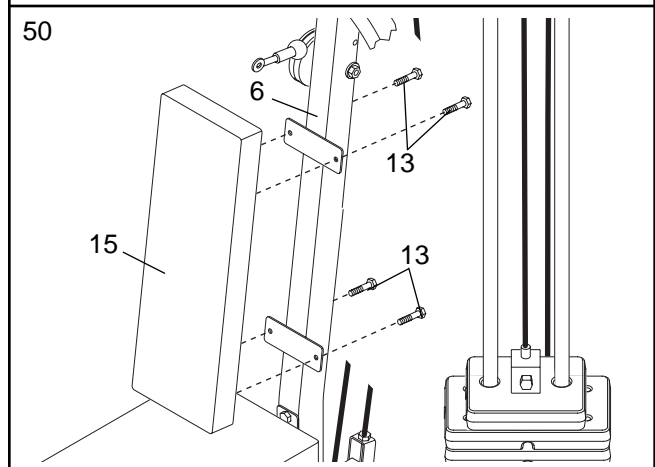
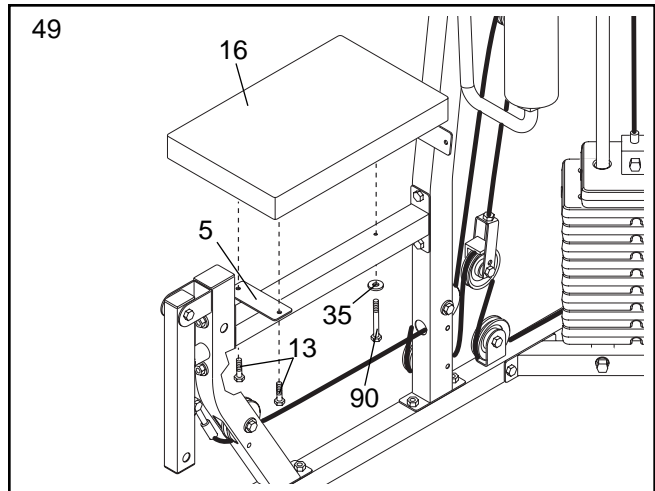

53. Insert the two Locking Pins (53) into the Butterfly Frame (9). Attach the tether on the Pins to the Butterfly Frame with a #8 x 3/4" Screw (68). Do not fully tighten the Screw.

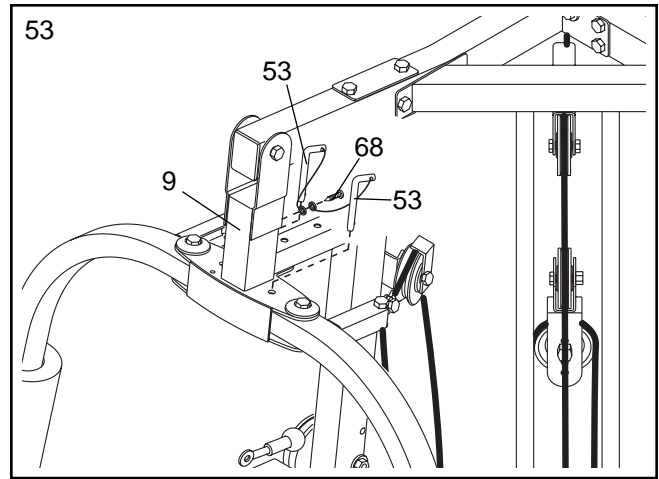

54. Make sure that all parts have been properly tightened. The use of all remaining parts will be explained in ADJUSTMENTS, starting on the following page.

Before using the weight system, pull each cable a few times to make sure that the cables move smoothly over the pulleys. If one of the cables does not move smoothly, find and correct the problem. **IMPORTANT: If the cables are not properly routed, they may be damaged when heavy weight is used. See the CABLE DIAGRAM on pages 24 and 25 of this manual for proper cable routing. If there is any slack in the cables, you will need to remove it by tightening the cables; see TIGHTENING THE CABLES on page 22.**

ADJUSTMENTS

This section explains how to adjust the weight system. See the EXERCISE GUIDELINES on page 26 for important information about how to get the most benefit from your exercise program. Also, refer to the accompanying exercise guide to see the correct form for each exercise.

Make sure all parts are properly tightened each time the weight system is used. Replace any worn parts immediately. The weight system can be cleaned with a damp cloth and a mild, non-abrasive detergent. Do not use solvents.

ATTACHING THE ACCESSORIES TO A PULLEY STATION

Attach the Lat Bar (42) to the High Cable (45) with a Cable Clip (52). For some exercises, the Chain (not shown) should be attached between the Lat Bar and the High Cable with two Cable Clips. **Adjust the length of the Chain between the Lat Bar and the High Cable so the Lat Bar is in the correct starting position for the exercise to be performed.**

The Handle (not shown) and Ab Strap (not shown) can be attached in the same manner. The accessories can be attached to the Low Cable (not shown) in the same manner.

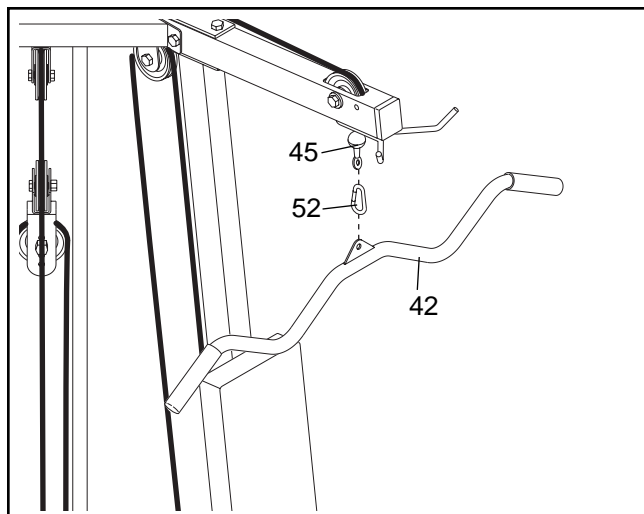

CHANGING THE WEIGHT SETTING

To change the weight setting of the weight stack, insert the Weight Pin (86) under the desired Weight (72). Be sure to insert the Weight Pin until the bent end of the Weight Pin is touching the Weights, and turn the bent end downward. The weight setting of the weight stack can be changed from 6 pounds to 106 pounds, in increments of 12.5 pounds. **Note: Due to the cables and pulleys, the actual amount of resistance at each exercise station may vary from the weight setting. Use the WEIGHT RESISTANCE CHART on page 23 to find the actual amount of resistance at each weight station.**

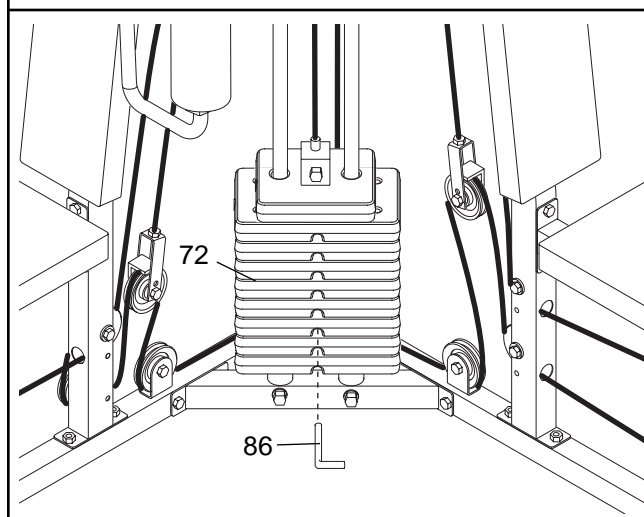

CONVERTING THE BUTTERFLY ARMS

To use the Butterfly Arms (10, 11) as butterfly arms, insert the Locking Pins (53) into the butterfly holes in the Right Upright (6).

To use the Butterfly Arms (10, 11) as press arms, insert the Locking Pins (53) into the press holes in the Butterfly Frame (9).

Make sure that the Locking Pins (53) are fully inserted into the same set of holes before performing any exercises.

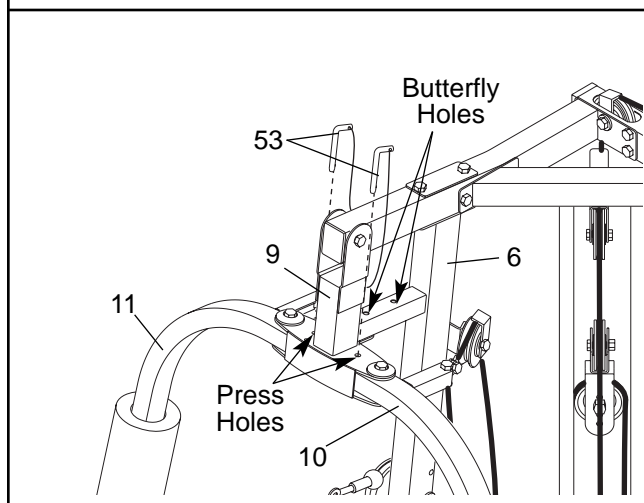

ADJUSTING THE CABLE TENSION

Woven cable, the type of cable used on the weight system, can stretch slightly when it is first used. If there is slack in the cables before resistance is felt, the cables should be tightened.

See drawing A. Slack can be removed by moving the 3 1/2" Pulley (38) and Cable Trap (91) to a higher set of holes in a Double "U"-Bracket (56). Remove the 3/8" Nylon Locknut (70) and the 3/8" x 2" Bolt (62) from the Cable Trap, the Pulley, and the Double "U"-Bracket. Re-attach the Pulley and the Cable Trap to the new set of holes in the Double "U"-Bracket with the Bolt and Locknut. **Make sure that the Cable Trap is in the proper position and that the Cable and Pulley move smoothly.**

Move the 3 1/2" Pulley (38) in the other Double "U"-Bracket (56) in the same manner.

See drawing B. Slack can be removed by moving the 3 1/2" Pulley (38) and the Cable Trap (91) to the higher set of holes in a "U"-Bracket (85). Remove the 3/8" Nylon Locknut (70) and the 3/8" x 2" Bolt (62) from the Cable Trap, the Pulley, and the "U"-Bracket. Re-attach the Pulley and the Cable Trap to the higher set of holes in the "U"-Bracket with the Bolt and Locknut. **Make sure that the Cable Trap is in the proper position and that the Cable and Pulley move smoothly.**

Move the 3 1/2" Pulley (38) in the other "U"-Bracket (85) in the same manner.

See drawing B. Slack can also be removed from the cables by tightening the 1/4" Nylon Locknuts (65) attaching a cable to either "U"-Bracket (85), or the Small "U"-Bracket (79). To do this, you may need to remove the 3 1/2" Pulley (38) from the "U"-Bracket, or remove the Small "U"-Bracket from the Weight Tube (not shown). Make sure that the cables are not too tight or the Top Weight (74) will be lifted off the weight stack.

ADJUSTING THE LEG PRESS PLATE

To adjust the Leg Press Plate (31), remove the Leg Press Pin (87) from the Leg Press Frame (30) and the Adjustment Tube (88). Move the Tube to the desired position and secure it in place with the Pin. **Be sure the Pin is turned to the locked position around the Leg Press Frame.**

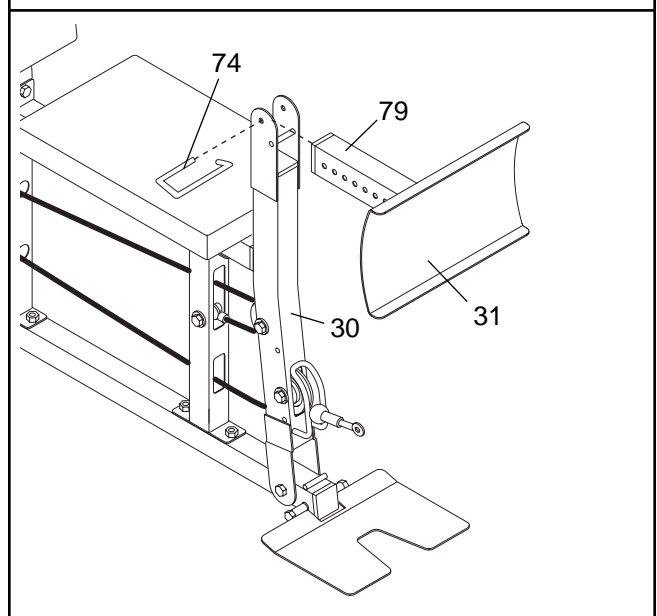
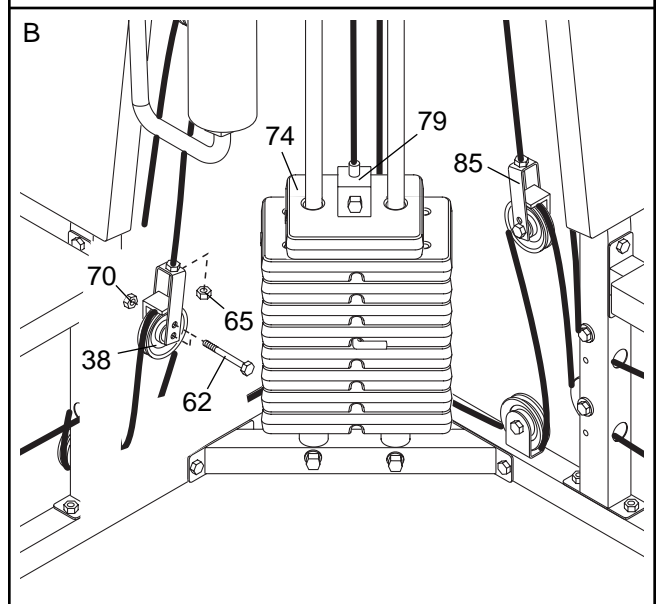
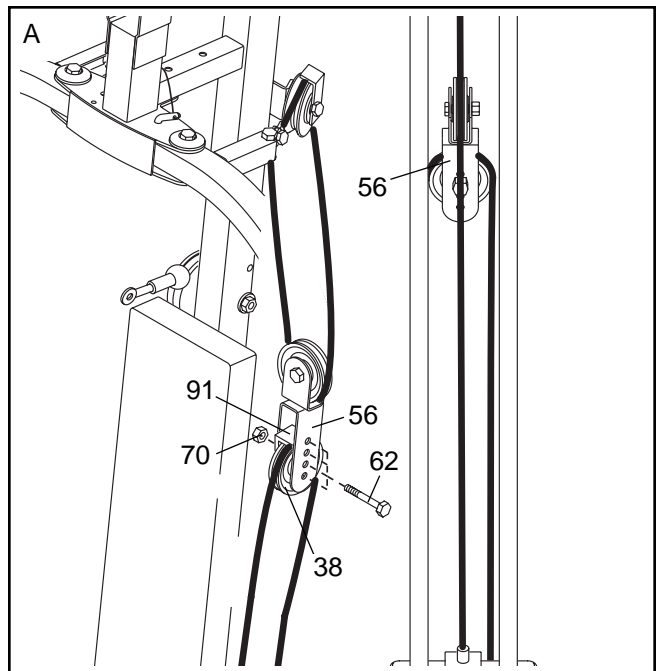

WEIGHT RESISTANCE CHART

The chart below shows the approximate weight resistance at each exercise station. "Top" refers to the 6 lb. top weight. The other numbers refer to the 12.5 lb. weight plates. Weight resistance shown for the butterfly arm station is for each butterfly arm. **Note: The actual resistance at each station may vary due to differences in individual weight plates as well as friction between the cables, pulleys, and weight guides.**

WEIGHT	HIGH PULLEY (lbs.)	PRESS ARM (lbs.)	LEG PRESS (lbs.)	BUTTER-FLY ARM (lbs.)	AB PULLEY (lbs.)	LEG LEVER (lbs.)	LOW PULLEY (lbs.)
Left Top	13	20	27	16	27	22	16
1	27	40	68	28	42	48	32
2	46	59	98	41	56	74	49
3	59	79	128	53	70	94	64
4	74	103	156	68	82	121	79
5	87	117	176	77	95	134	93
6	102	136	202	87	110	155	108
7	115	161	237	97	125	173	122
8	129	180	265	108	139	193	137

CABLE DIAGRAMS

The cable diagrams below show the proper routing of the High Cable (45), the Butterfly Cable (46), the Low Cable (47), the Leg Press Cable (95), and the Leg Lever Cable (96). Use the diagrams to make sure that the cables and the cable traps have been assembled correctly. If the cables have not been correctly routed, the weight system will not function properly and damage may occur. The numbers show the correct route for each cable. **Make sure that the cable traps do not touch or bind the cables.**

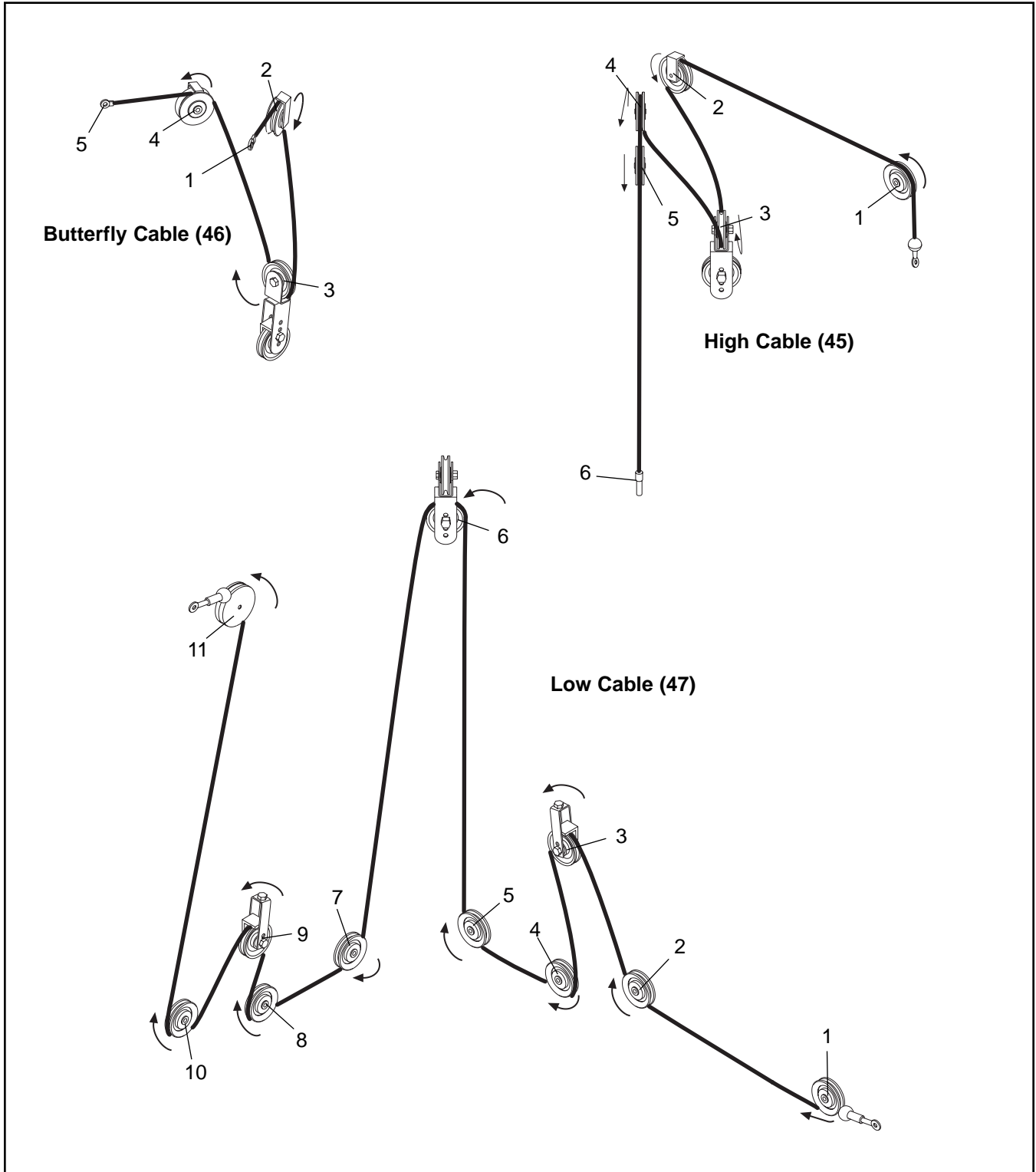

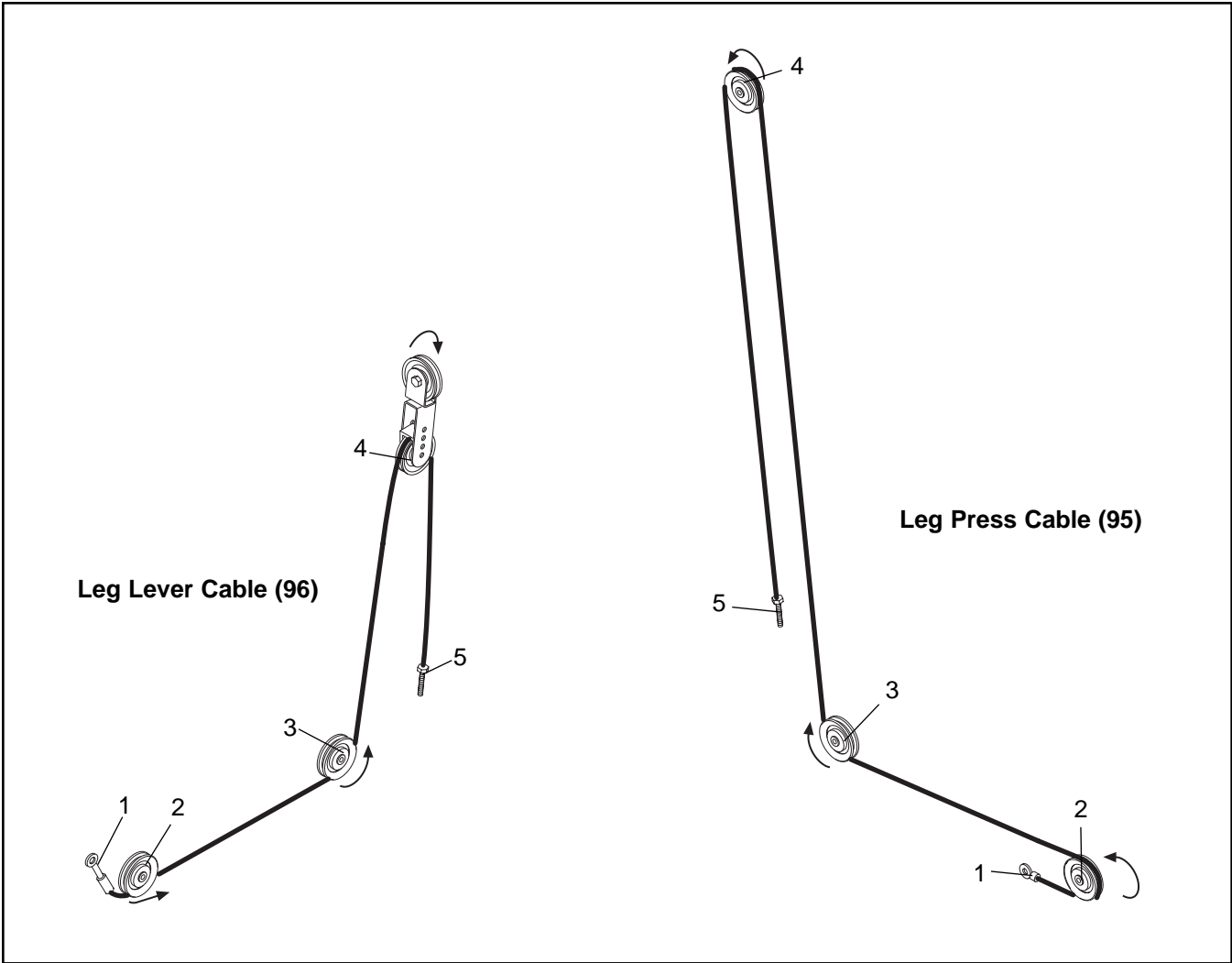

CABLE ID CHART		
		— (46) 47 3/7"
		— (96) 95 1/2"
		— (95) 148 1/4"
		— (47) 276 3/4"
		— (45) 116 3/4"

EXERCISE GUIDELINES

THE FOUR BASIC TYPES OF WORKOUTS

Muscle Building

To increase the size and strength of your muscles, push them close to their maximum capacity. Your muscles will continually adapt and grow as you progressively increase the intensity of your exercise. You can adjust the intensity level of an individual exercise in two ways:

- by changing the amount of weight used
- by changing the number of repetitions or sets performed. (A “repetition” is one complete cycle of an exercise, such as one sit-up. A “set” is a series of repetitions.)

The proper amount of weight for each exercise depends upon the individual user. You must gauge your limits and select the amount of weight that is right for you. Begin with 3 sets of 8 repetitions for each exercise you perform. Rest for 3 minutes after each set. When you can complete 3 sets of 12 repetitions without difficulty, increase the amount of weight.

Toning

You can tone your muscles by pushing them to a moderate percentage of their capacity. Select a moderate amount of weight and increase the number of repetitions in each set. Complete as many sets of 15 to 20 repetitions as possible without discomfort. Rest for 1 minute after each set. Work your muscles by completing more sets rather than by using high amounts of weight.

Weight Loss

To lose weight, use a low amount of weight and increase the number of repetitions in each set. Exercise for 20 to 30 minutes, resting for a maximum of 30 seconds between sets.

Cross Training

Cross training is an efficient way to get a complete and well-balanced fitness program. An example of a balanced program is:

- Plan weight training workouts on Monday, Wednesday, and Friday.
- Plan 20 to 30 minutes of aerobic exercise, such as cycling or swimming, on Tuesday and Thursday.
- Rest from both weight training and aerobic exercise for at least one full day each week to give your body time to regenerate.

The combination of weight training and aerobic exercise will reshape and strengthen your body, plus develop your heart and lungs.

PERSONALIZING YOUR EXERCISE PROGRAM

Determining the exact length of time for each workout, as well as the number of repetitions or sets completed, is an individual matter. It is important to avoid overdoing it during the first few months of your exercise program. You should progress at your own pace and be sensitive to your body’s signals. If you experience pain or dizziness at any time while exercising, stop immediately and begin cooling down. Find out what is wrong before continuing. Remember that adequate rest and a proper diet are important factors in any exercise program.

WARMING UP

Begin each workout with 5 to 10 minutes of stretching and light exercise to warm up. Warming up prepares your body for more strenuous exercise by increasing circulation, raising your body temperature and delivering more oxygen to your muscles.

WORKING OUT

Each workout should include 6 to 10 different exercises. Select exercises for every major muscle group, emphasizing areas that you want to develop most. To give balance and variety to your workouts, vary the exercises from session to session.

Schedule your workouts for the time of day when your energy level is the highest. Each workout should be followed by at least one day of rest. Once you find the schedule that is right for you, stick with it.

EXERCISE FORM

Maintaining proper form is an essential part of an effective exercise program. This requires moving through the full range of motion for each exercise, and moving only the appropriate parts of the body. Exercising in an uncontrolled manner will leave you feeling exhausted. On the exercise guide accompanying this manual you will find photographs showing the correct form for several exercises, and a list of the muscles affected. Refer to the muscle chart on page 27 to find the names of the muscles.

The repetitions in each set should be performed smoothly and without pausing. The exertion stage of each repetition should last about half as long as the return stage. Proper breathing is important. Exhale during the exertion stage of each repetition and inhale during the return stroke. Never hold your breath.

Rest for a short period of time after each set. The ideal resting periods are:

- Rest for three minutes after each set for a muscle building workout.
- Rest for one minute after each set for a toning workout.
- Rest for 30 seconds after each set for a weight loss workout.

Plan to spend the first couple of weeks familiarizing yourself with the equipment and learning the proper form for each exercise.

COOLING DOWN

End each workout with 5 to 10 minutes of stretching. Include stretches for both your arms and legs. Move

slowly as you stretch and do not bounce. Ease into each stretch gradually and go only as far as you can without strain. Stretching at the end of each workout is an effective way to increase flexibility.

STAYING MOTIVATED

For motivation, keep a record of each workout. list the date, the exercises performed, the weight used, and the numbers of sets and repetitions completed. Record your weight and key body measurements at the end of every month. Remember, the key to achieving the greatest results is to make exercise a regular and enjoyable part of your everyday life.

MUSCLE CHART

- A. Sternomastoid (neck)
- B. Pectoralis Major (chest)
- C. Biceps (front of arm)
- D. Obliques (waist)
- E. Brachioradials (forearm)
- F. Hip Flexors (upper thigh)
- G. Abductor (outer thigh)
- H. Quadriceps (front of thigh)
- I. Sartorius (front of thigh)
- J. Tibialis Anterior (front of calf)
- K. Soleus (front of calf)
- L. Rectus Abdominus (stomach)
- M. Adductor (inner thigh)
- N. Trapezius (upper back)
- O. Rhomboideus (upper back)
- P. Deltoid (shoulder)
- Q. Triceps (back of arm)
- R. Latissimus Dorsi (mid back)
- S. Spinae Erectors (lower back)
- T. Gluteus Medius (hip)
- U. Gluteus Maximus (buttocks)
- V. Hamstring (back of leg)
- W. Gastrocnemius (back of calf)

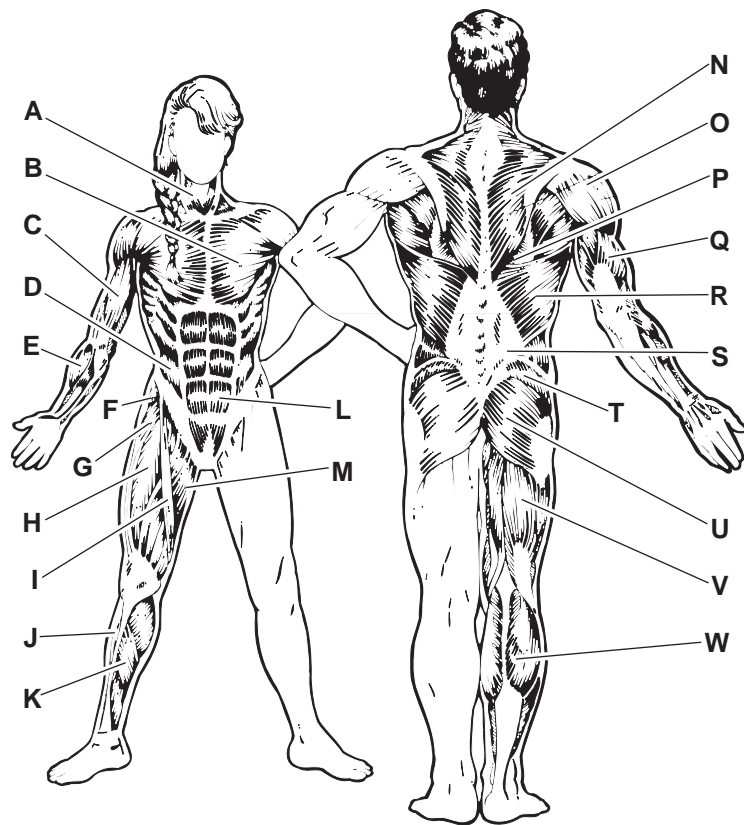

PART IDENTIFICATION CHART—Model No. 831.159823

R0103A

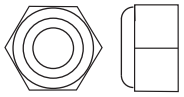

1/4" Nylon Locknut (65)

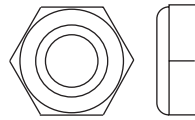

3/8" Nylon Jamnut (50)

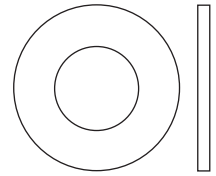

3/8" Washer (75)

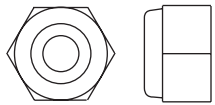

5/16" Nylon Locknut (71)

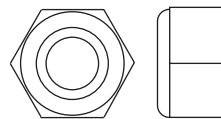

3/8" Nylon Locknut (70)

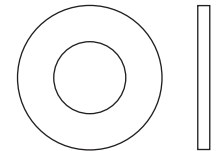

5/16" Washer (56)

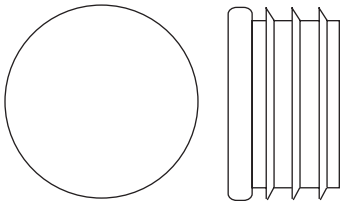

1" Round Inner Cap (24)

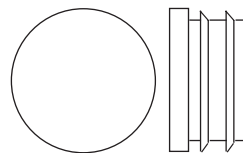

3/4" Round Inner Cap (27)

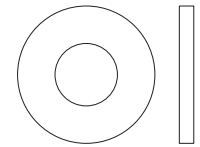

1/4" Washer (35)



1 1/2" x 2" Inner Cap (23)

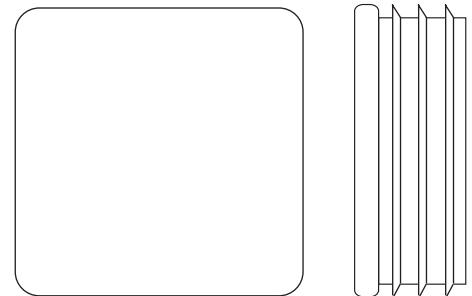

1 1/2" Square Inner Cap (41)



2" x 2 1/2" Inner Cap (22)

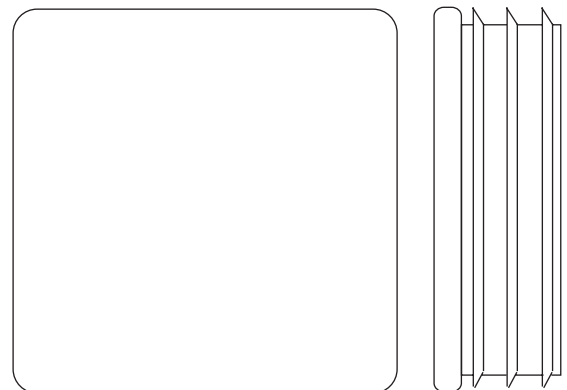

2" Square Inner Cap (33)

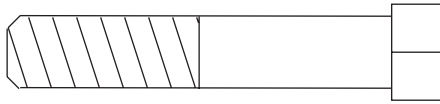

3/8" x 2" Bolt (62)

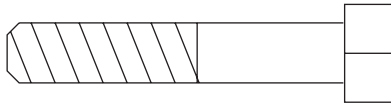

5/16" x 1 3/4" Bolt (69)

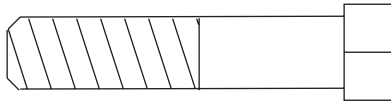

3/8" x 1 3/4" Bolt (66)

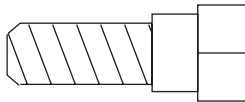

5/16" x 1" Shoulder Bolt (78)

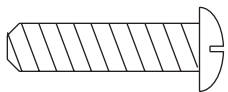

1/4" x 1" Screw (77)

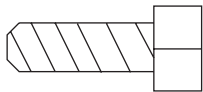

1/4" x 3/4" Bolt (13)

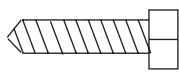

#8 x 3/4" Screw (68)

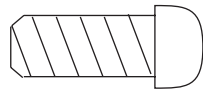

5/16" x 3/4" Button Head Bolt (64)

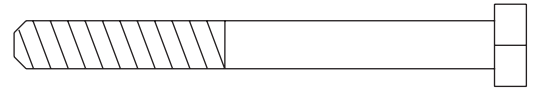

1/4" x 2 1/2" Bolt (90)

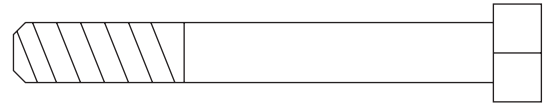

5/16" x 2 1/2" Bolt (89)

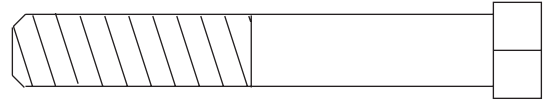

3/8" x 2 1/2" Bolt (63)

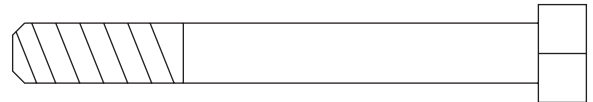

5/16" x 2 3/4" Bolt (60)



3/8" x 2 3/4" Bolt (81)



5/16" x 2 1/2" Carriage Bolt (57)

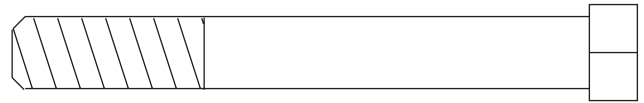

3/8" x 3" Bolt (61)

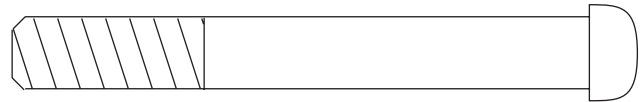

3/8" x 3" Button Head Bolt (97)

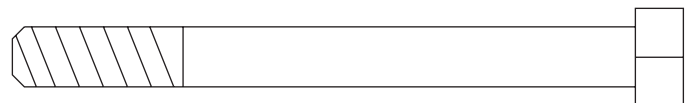

5/16" x 3 1/4" Bolt (59)



3/8" x 3 3/4" Bolt (84)

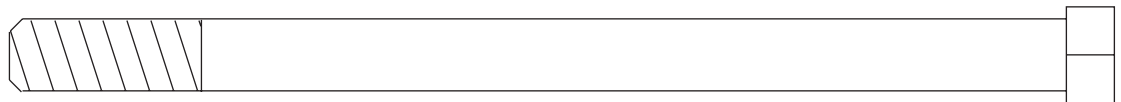

3/8" x 5 1/2" Bolt (58)

PART LIST—Model No. 831.159823

R0203A

Key No.	Qty.	Description	Key No.	Qty.	Description
1	1	Right Base	53	2	Locking Pin
2	1	Left Base	54	4	Butterfly Cap
3	1	Left Top Frame	55	4	Plastic Washer
4	1	Leg Lever	56	2	Double "U"-Bracket
5	1	Right Seat Frame	57	10	5/16" x 2 1/2" Carriage Bolt
6	1	Right Upright	58	1	3/8" x 5 1/2" Bolt
7	1	Left Upright	59	10	5/16" x 3 1/4" Bolt
8	1	Right Top Frame	60	13	5/16" x 2 3/4" Bolt
9	1	Butterfly Frame	61	2	3/8" x 3" Bolt
10	1	Left Butterfly Arm	62	13	3/8" x 2" Bolt
11	1	Right Butterfly Arm	63	3	3/8" x 2 1/2" Bolt
12	2	Press Handle	64	4	5/16" x 3/4" Button Head Bolt
13	12	1/4" x 3/4" Bolt	65	3	1/4" Nylon Locknut
14	1	Center Top Frame	66	2	3/8" x 1 3/4" Bolt
15	2	Backrest	67	1	Center Base
16	2	Seat	68	4	#8 x 3/4" Screw
17	1	Long Pad Tube	69	1	5/16" x 1 3/4" Bolt
18	4	Foam Pad	70	28	3/8" Nylon Locknut
19	2	Large Foam Pad	71	38	5/16" Nylon Locknut
20	2	Weight Guide	72	8	Weight
21	2	Support Plate	73	1	Right Leg
22	7	2" x 2 1/2" Inner Cap	74	1	Top Weight
23	4	1 1/2" x 2" Inner Cap	75	25	3/8" Washer
24	2	1" Round Inner Cap	76	2	Foam Grip
25	1	Bumper	77	1	#10 x 1" Screw
26	23	5/16" Washer	78	3	5/16" x 1" Shoulder Bolt
27	4	3/4" Round Inner Cap	79	1	Small "U"-Bracket
28	1	Base Cap	80	2	Long Spacer
29	1	Left Seat Frame	81	9	3/8" x 2 3/4" Bolt
30	1	Leg Press Frame	82	1	Weight Tube
31	1	Leg Press Plate	83	2	Weight Bumper
32	1	Weight Tube Bumper	84	2	3/8" x 3 3/4" Bolt
33	3	2" Square Inner Cap	85	2	"U"-Bracket
34	16	1/2" Spacer	86	1	Weight Pin
35	5	1/4" Washer	87	1	Leg Press Pin
36	1	Left Leg	88	1	Adjustment Tube
37	1	Left Base Plate	89	1	5/16" x 2 1/2" Bolt
38	23	3 1/2" Pulley	90	2	1/4" x 2 1/2" Bolt
39	2	"V"-Pulley	91	6	Cable Trap
40	2	Long Cable Trap	92	2	Pulley Cover
41	1	1 1/2" Square Inner Cap	93	1	Ab Strap
42	1	Lat Bar	94	1	Short Pad Tube
43	2	Handgrip	95	1	Leg Press Cable
44	2	Weight Guide Bushing	96	1	Leg Lever Cable
45	1	High Cable	97	2	3/8" x 3" Button Head Bolt
46	1	Butterfly Cable	98	1	Rubber Bumper
47	1	Low Cable	99	4	Nut Clips
48	2	Pivot Bracket	#	1	User's Manual
49	1	Chain	#	1	Exercise Guide
50	6	3/8" Nylon Jamnut	#	1	Allen Wrench
51	1	Handle	#	1	Grease Packet
52	3	Cable Clip			

Note: "#" indicates a non-illustrated part. Specifications are subject to change without notice.

EXPLODED DRAWING—Model No. 831.159823

R0203A

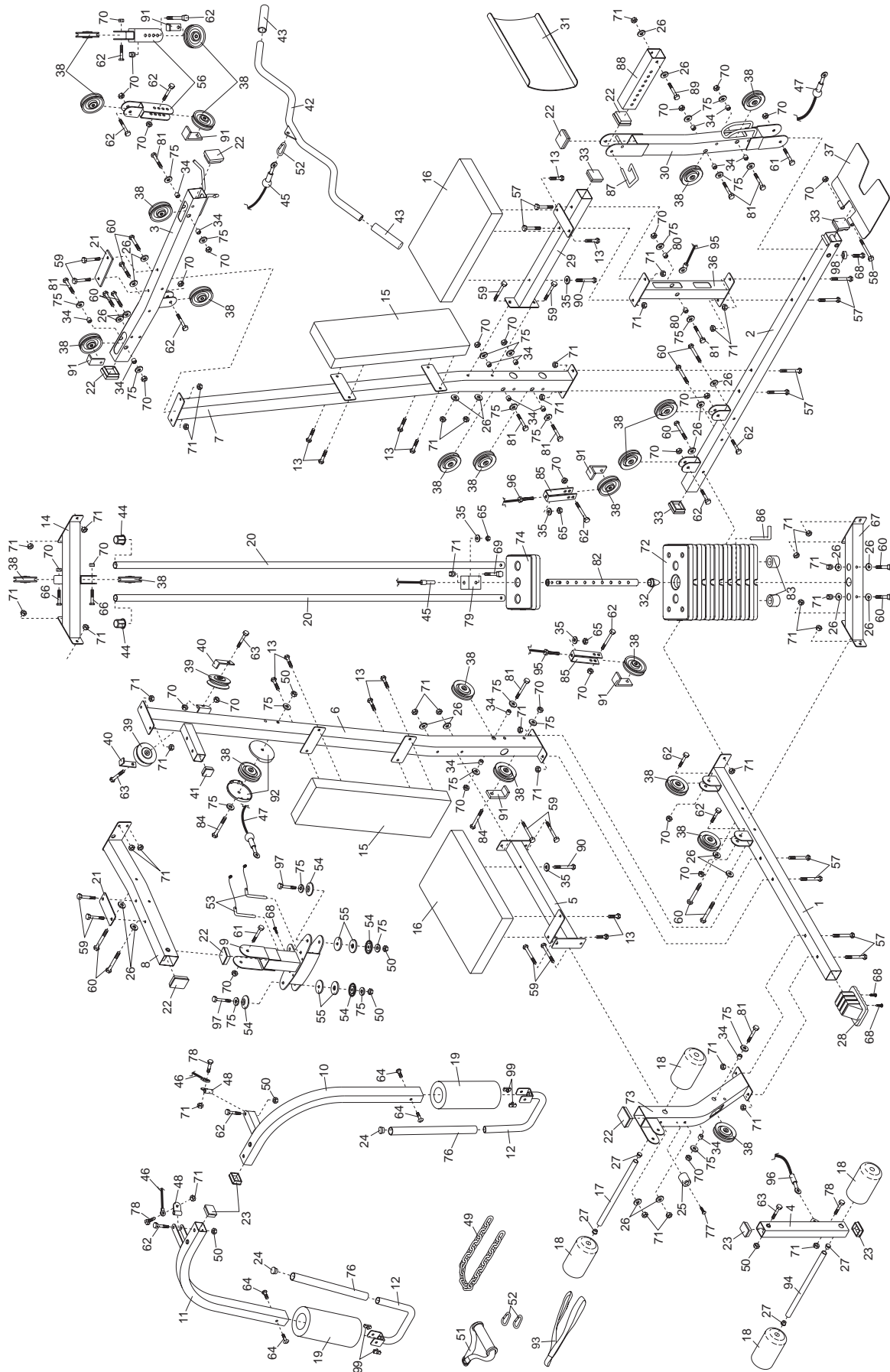

Get it fixed, at your home or ours!

Your Home

For repair – **in your home** – of **all** major brand appliances, lawn and garden equipment, or heating and cooling systems, **no matter who made it, no matter who sold it!**

For the replacement parts, accessories, and user's manuals that you need to do-it-yourself.

For Sears professional installation of home appliances and items like garage door openers and water heaters.

1-800-4-MY-HOME®

(1-800-469-4663)

www.sears.com

Anytime, day or night

(U.S.A. and Canada)

www.sears.ca

Our Home

For repair of carry-in products like vacuums, lawn equipment, and electronics, call or go on-line for the location of your nearest **Sears Parts and Repair Center.**

1-800-488-1222 Anytime, day or night (U.S.A. only)

www.sears.com

To purchase a protection agreement (U.S.A.) or maintenance agreement (Canada) on a product serviced by Sears:

1-800-827-6655 (U.S.A.)

1-800-361-6665 (Canada)

Para pedir servicio de reparación a domicilio, y para ordenar piezas:

1-888-SU-HOGARSM (1-888-784-6427)

SEARS

® Registered Trademark / ™ Trademark / ™ Service Mark of Sears, Roebuck and Co.
® Marca Registrada / ™ Marca de Fábrica / ™ Marca de Servicio de Sears, Roebuck and Co.

FULL 90 DAY WARRANTY

For 90 days from the date of purchase, if failure occurs due to defect in material or workmanship in this Sears Weight System Exerciser, contact the nearest Sears Service Center throughout the United States and Sears will repair or replace the Weight System Exerciser, free of charge.

This warranty does not apply when the Weight System Exerciser is used commercially or for rental purposes.

This warranty gives you specific legal rights, and you may also have other rights which vary from state to state.

Sears, Roebuck and Co., Dept. 817WA, Hoffman Estates, IL 60179