

3+



**SONG MODE
MODE CHANSON**

Press the keynote button on the front to activate the music
Appuyez sur le bouton principal située à l'avant pour activer la musique.



**SING ALONG
CHANTEZ**

Sing or speak into the top of the microphone to activate the voice changing amplification, and hear your voice louder through the built-in speaker. The top ring will light up as the music is playing.
Chantez ou parlez dans la partie supérieure du microphone pour activer l'amplification de changement de voix, et votre voix sera plus forte dans le haut-parleur intégré. L'anneau supérieur s'allumera lorsque la musique joue.

W!LDBRAIN®
THE MAGIC STORE

Yo Gabba Gabba! TM & © 2008 GabbaCaDabra LLC. Distributed by Spin Master under license from GabbaCaDabra LLC. Spin Master Logo & © 2008, Spin Master Ltd. All rights reserved.
Yo Gabba Gabba! TM & © 2008 GabbaCaDabra LLC. Distribué par Spin Master sous licence GabbaCaDabra LLC. Spin Master Logo & © 2008, Spin Master Ltd. Tous droits réservés.

Spin Master Ltd., 450 Front Street West, Toronto, ON M5V 1B6 Canada
Spin Master, Inc., PMB #10053, 300 International Drive, Suite 100, Williamsville, NY 14221, USA
Spin Master France - 36 rue de Silly - 92100 Boulogne Billancourt - France
Spin Master Toys Far East Limited, Rm #1113, 11/E, Chinachem Golden Plaza, 77 Mody Rd., Tsimshatsui E., Kowloon, HK
Spin Master Toys UK Ltd Meadowbank, Furlong Road, Bourne End, Bucks, SL8 5AJ, United Kingdom

CUSTOMER SERVICE
After Hours Service: 0870 850 8408 Email: ukservice@spinmaster.com
North American Consumer Information / Phone: 1-800-622-8339 Fax: 416-364-8005 Web: www.spinmaster.com
MADE IN CHINA. Colors and decoration may vary. Conforms to toy safety standards STM F963.

CUSTOMER SERVICE
En dehors des heures de bureau: 0870 850 8408 Email: ukservice@spinmaster.com
Information Consommateur en Amérique du Nord / Téléphone: 1-800-622-8339 Fax: 416-364-8005 Web: www.spinmaster.com
FABRIQUÉ EN CHINE. Les couleurs et la décoration peuvent varier. Conforme aux normes de sécurité en matière de jouet ASTM F963.



**Razzle
Dazzle
Microphone™**

INSTRUCTIONS / DIRECTIVES

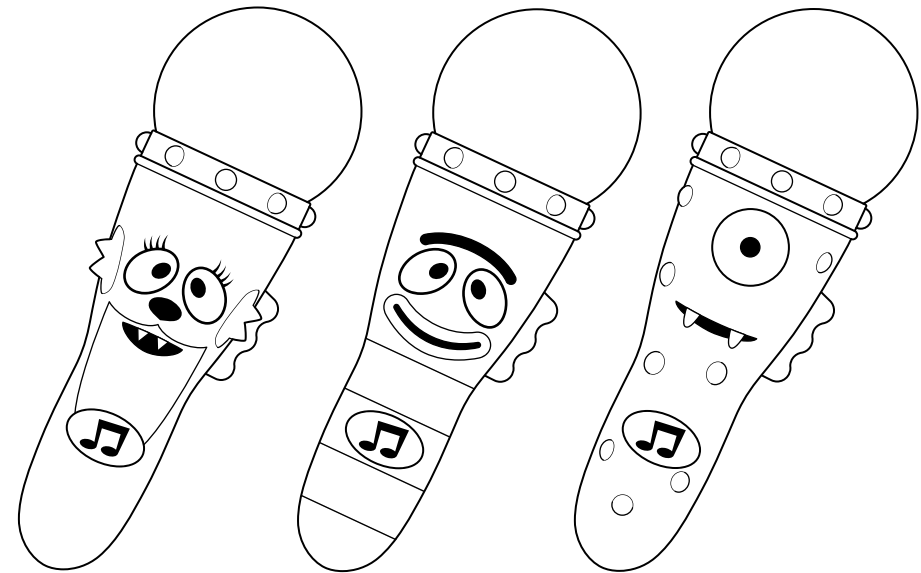
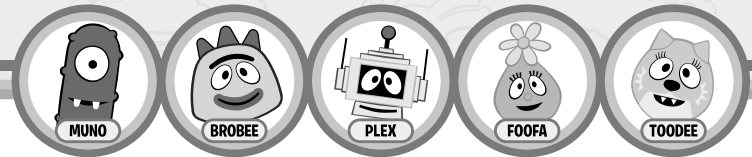

WARNING: If you have experienced light-induced seizures in the past, do not use this toy. Requires 3 "AAA" batteries (included). Please remove packaging material before giving to child. These instructions contain important information - Keep them for future reference.

WARNING: If you have experienced light-induced seizures in the past, do not use this toy. Nécessite 3 piles AAA (fournies). Please remove packaging material before giving to child. Ces instructions comportent des informations importantes. Conservez-les pour pouvoir les consulter ultérieurement.



T24324-0001-NBL-R0

BATTERY INSTALLATION / REPLACEMENT INSTALLATION ET CHANGEMENT DES PILES

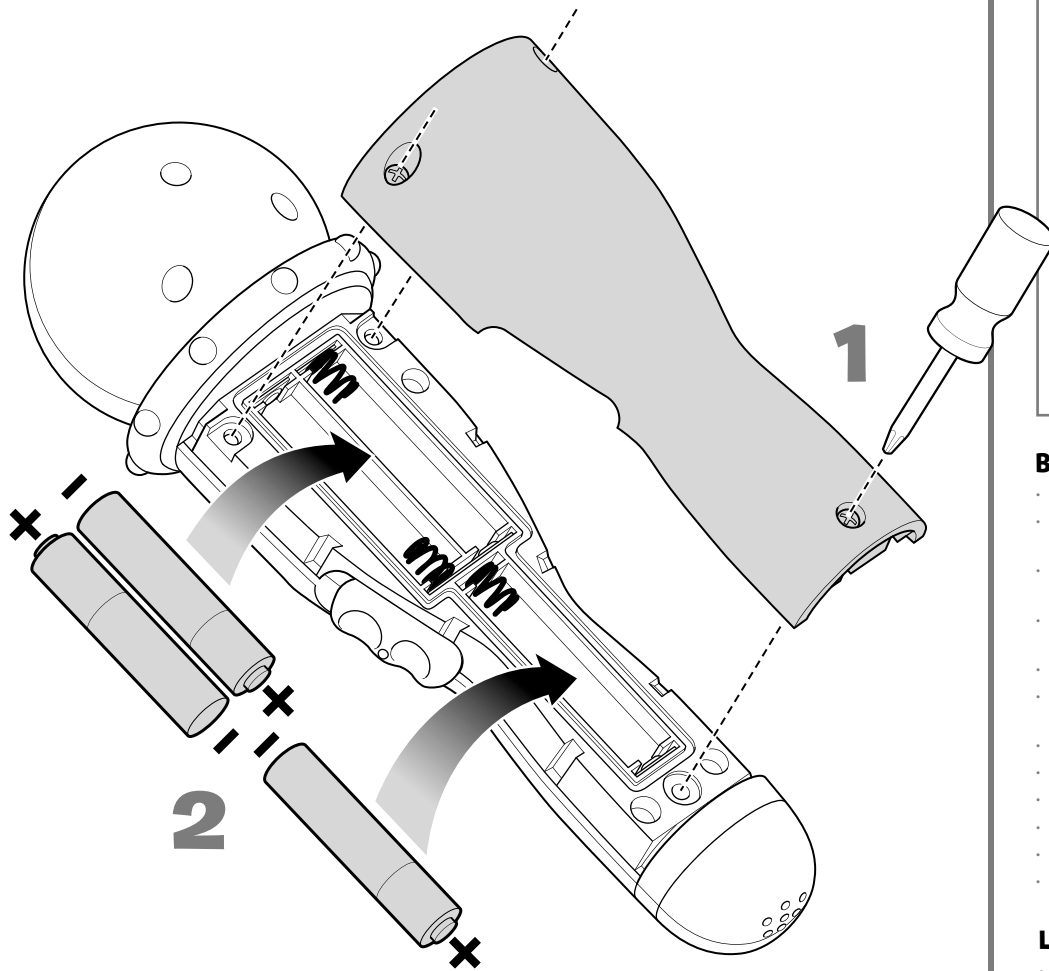

Use a Phillips head screwdriver (not included) to remove battery cover [1]. Remove batteries and replace with 3 "AAA" alkaline batteries in the orientation shown [2]. Replace battery cover and tighten screw. Use only alkaline batteries for longer life. Replace batteries if lights and sounds play slowly or distort.

À l'aide d'un tournevis cruciforme (exclu), retirez le couvercle du compartiment des piles. [1] Retirez les piles et remplacez-les par 3 piles alcalines AAA en les orientant comme indiqué. [2] Remettez le couvercle du compartiment et serrez la vis. Employez exclusivement des piles alcalines, qui durent plus longtemps. Changez les piles si les voyants ou les sons s'affaiblissent ou se déforment.

Warning: Changes or modifications to this unit not expressly approved by the party responsible for compliance could void the user's authority to operate the equipment.

NOTE: This equipment has been tested and found to comply with the limits for a Class B digital device, pursuant to Part 15 of the FCC Rules. These limits are designed to provide reasonable protection against harmful interference in a residential installation. This equipment generates, uses and can radiate radio frequency energy and if not installed and used in accordance with the instructions, may cause harmful interference to radio communications. However, there is no guarantee that interference will occur in a particular installation. If this equipment does cause harmful interference to radio or television reception, which can be determined by turning the equipment off and on, the user is encouraged to try to correct the interference by one or more of the following measures:

- Reorient or relocate the receiving antenna.
- Increase the separation between the equipment and receiver.
- Connect the equipment into an outlet on a circuit different from that to which the receiver is needed.
- Consult the dealer or an experienced radio/TV technician for help.

BATTERY SAFETY INFORMATION

- Non-rechargeable batteries are not to be recharged.
- Rechargeable batteries are to be removed from the toy before being charged (if designed to be removable).
- Rechargeable batteries are only to be charged under adult supervision (if designed to be removable).
- Do not mix alkaline, standard (carbon-zinc), or rechargeable (nickel-cadmium) batteries or different types of batteries.
- Do not mix old and new batteries.
- Only batteries of the same or equivalent type as recommended are to be used.
- Batteries are to be inserted with the correct polarity.
- Exhausted batteries are to be removed from the toy.
- The supply terminals are not to be short-circuited.
- Dispose of battery(ies) safely.
- Batteries should always be replaced by an adult.
- Use alkaline batteries only for best performance.

LES PILES ET VOTRE SÉCURITÉ

- Il ne faut pas recharger les piles non rechargeables.
- Il faut retirer les piles rechargeables du jouet avant de les charger (si on peut les retirer).
- Les piles rechargeables ne doivent être rechargées que sous la surveillance d'un adulte (si on peut les retirer).
- Ne mélangez pas des piles alcalines et des piles ordinaires (carbone-zinc) ou des piles rechargeables (nickel-cadmium).
- Ne mélangez pas des piles anciennes et des piles neuves.
- Il ne faut employer que des piles de même genre ou d'un genre équivalent à celui conseillé.
- Il faut retirer les piles épuisées du jouet.
- Il ne faut pas court-circuiter les bornes d'alimentation. Mettez les piles au rebut en respectant les usages.
- Un adulte doit toujours procéder à l'installation des piles.
- Servez-vous exclusivement de piles alcalines pour un fonctionnement optimal du jouet.

FEATURES CARACTÉRISTIQUES

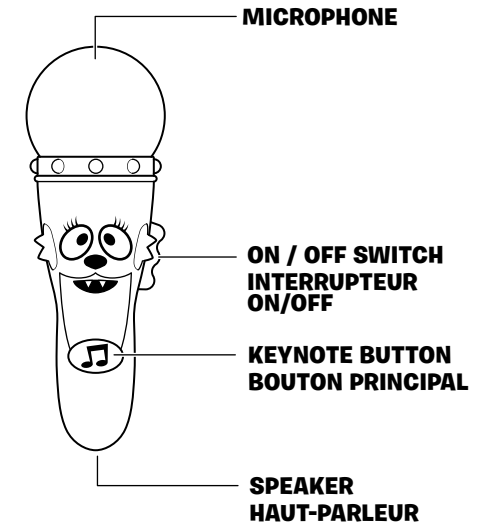

PLAYTIME JEU

Move the ON /OFF/ TRY ME switch to the "ON" position.

Placez l'interrupteur TRY ME/OFF/ON (ESSAYEZ-MOI FERMÉ/OUVERT) en position « ON », tel qu'indiqué.

